

UBA2080; UBA2080A; UBA2081

Half-bridge driver IC

Rev. 3 — 18 June 2012

Product data sheet

1. General description

The UBA2080(A) and UBA2081 are high voltage monolithic integrated circuits made using the latch-up free Silicon-On-Insulator (SOI) process. The circuit is designed for driving MOSFETs in a half-bridge configuration.

2. Features and benefits

- Latch-up free and robust half bridge driver
- Output driver capability: $I_{O(\text{sink})} = 400 \text{ mA}$ and $I_{O(\text{source})} = 200 \text{ mA}$
- Maximum frequency 800 kHz
- UBA2080:
 - ◆ Outputs in phase with HIN and LIN inputs
 - ◆ Overlap protection
- UBA2081:
 - ◆ Outputs in phase with CLK input
 - ◆ Adjustable dead-time
 - ◆ Low active shutdown input

3. Applications

- Driver (via external MOSFETs) for any kind of load in a half-bridge configuration
- UBA2080A:
 - ◆ Selectable between UBA2080 and UBA2081 functionality
 - ◆ Thermally enhanced package for high frequency operation.

4. Ordering information

Table 1. Ordering information

Type number	Package		
	Name	Description	Version
UBA2080P	DIP8	plastic dual in-line package; 8 leads	SOT97-1
UBA2081P			
UBA2080T	SO8	plastic small outline package; 8 leads	SOT96-1
UBA2081T			
UBA2080AT	SO14	plastic small outline package; 14 leads	SOT108-1



5. Block diagram

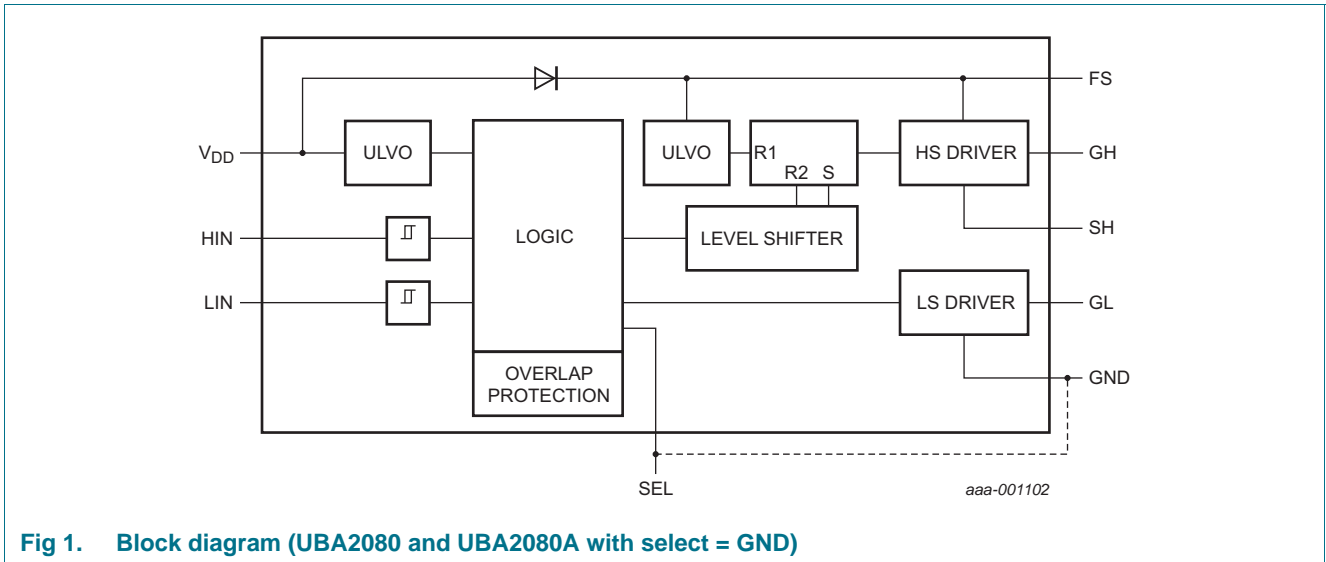

Fig 1. Block diagram (UBA2080 and UBA2080A with select = GND)

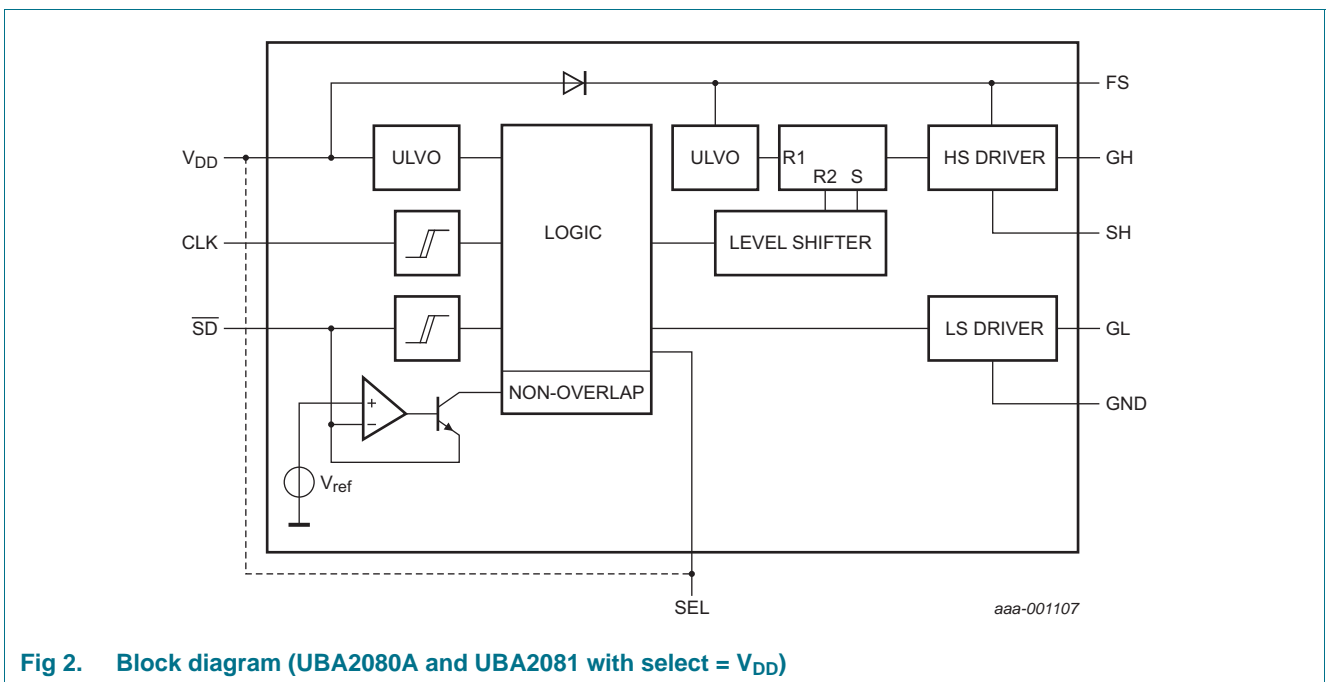
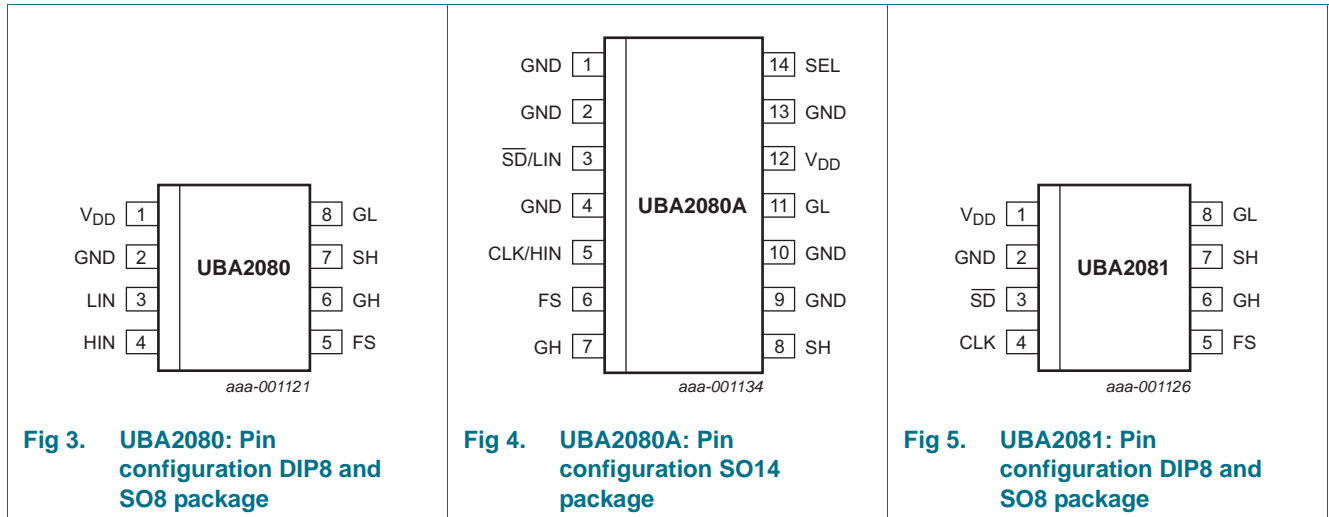

Fig 2. Block diagram (UBA2080A and UBA2081 with select = V_{DD})

Refer to [Figure 7](#) and [Figure 8](#) for detailed information on the required application components.

6. Pinning information

6.1 Pinning



6.2 Pin description

Table 2. Pin description UBA2080/UBA2081 DIP8 and SO8

Symbol	Pin		Description
	UBA2080 (DIP8/SO8)	UBA2081 (DIP8/SO8)	
V _{DD}	1		IC supply
GND	2		IC ground and low-side driver return
LIN	3	-	low-side driver logic input
$\overline{\text{SD}}$	-	3	low active analog shutdown input and non-overlap time setting
HIN	4	-	high-side driver logic input
CLK	-	4	clock logic input
FS	5		floating supply voltage
GH	6		high-side MOSFET gate
SH	7		high-side MOSFET source
GL	8		low-side MOSFET gate

Table 3. Pin description UBA2080AT (SO14)

Symbol	Pin	Description
GND	1, 2, 4, 9, 10, 13	IC ground and low side driver return
$\overline{\text{SD}}$ /LIN	3	low-side driver logic input or low active shutdown and non-overlap time setting
CLK/HIN	5	high-side driver logic input or clock logic input
FS	6	floating supply voltage
SH	8	high-side MOSFET source

Table 3. Pin description UBA2080AT (SO14) ...continued

Symbol	Pin	Description
GH	7	high-side MOSFET gate
GL	11	low-side MOSFET gate
V _{DD}	12	IC supply
SEL	14	select UBA2080 or UBA2081 functionality; only connect to GND or V _{DD}

7. Functional description

7.1 Start-up state

The IC enters the start-up state when the supply voltage on pin V_{DD} increases. In the start-up state, the high-side power transistor is non-conducting and the low-side power transistor is switched on. The internal circuit is reset and the capacitor on the bootstrap pin FS is charged. The start-up state is defined until the value of V_{DD} = the V_{DD(start)} value. After which the IC switches to the oscillation state.

The circuit enters the start-up state again when the voltage on pin V_{DD} < V_{DD(stop)}.

7.2 UBA2080 oscillation state

In the oscillation state, the output voltage of the GL and GH drivers depend on the logical signals HIN and LIN (see [Table 4](#)).

To prevent cross conduction in the half-bridge MOSFETs, the combination HIN = LIN = 1 is not allowed. Both GL and GH are LOW under this condition.

Table 4. UBA2080 Logic table

State	HIN	LIN	GH	GL
Start-up	-	-	LOW	HIGH
Oscillation	0	0	LOW	LOW
Oscillation	0	1	LOW	HIGH
Oscillation	1	0	HIGH	LOW
Oscillation	1	1	LOW	LOW

7.3 UBA2081 oscillation state

In the oscillation state, the output voltage of the GL and GH drivers depend on the logical signals CLK and SD (see [Table 5](#)).

Table 5. UBA2081 Logic table

State	CLK	SD	GH	GL
Start-up	-	-	LOW	HIGH
Oscillation	0	0	LOW	HIGH
Oscillation	1	0	HIGH	LOW
Oscillation	0	1	LOW	LOW
Oscillation	1	1	LOW	LOW

7.4 UBA2081 non-overlap time

The external resistor (R_{SD}) on pin SD sets the non-overlap time of the UBA2081. The relationship between this resistor value and actual dead-time is listed in [Figure 6](#).

It is essential to add a 10 nF to 100 nF decoupling capacitor across R_{SD} to ensure a noise immune dead-time system.

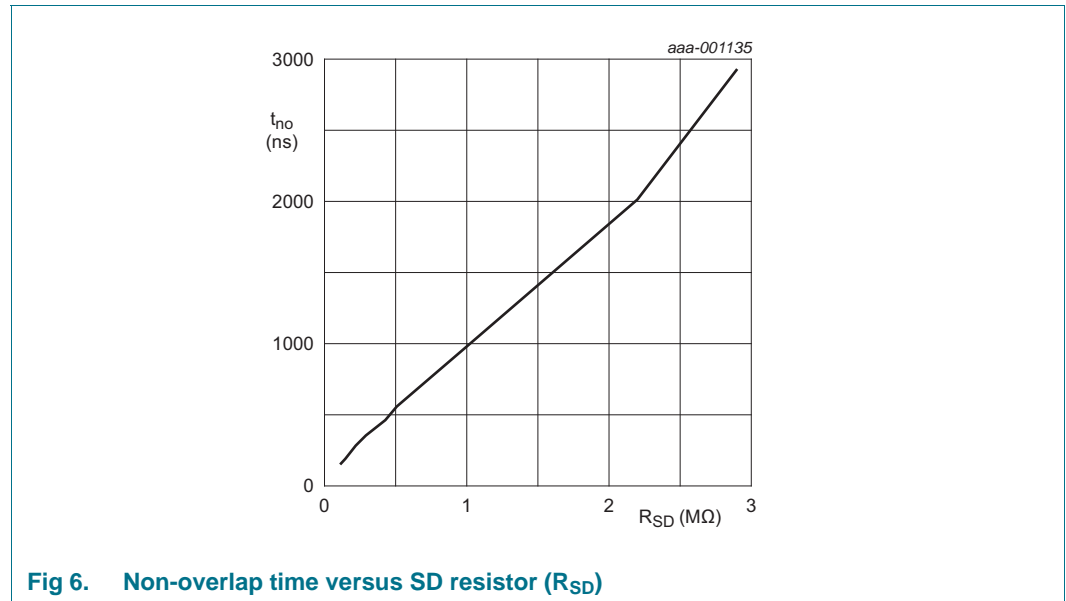

Fig 6. Non-overlap time versus SD resistor (R_{SD})

7.5 UBA2081 shutdown protection

When the voltage at pin \overline{SD} is pulled below V_{IH} , the internal sink drivers of the pins GL and GH are immediately enabled to switch off the external power MOSFETs.

The shutdown comparator has a hysteresis of $V_{hys}(\overline{SD})$ to avoid multiple switching.

Preferably, pin \overline{SD} is pulled low via a collector of a transistor (see application schematic) to avoid loading of this pin (Influences the non-overlap time settings) at normal operation.

7.6 UBA2080 overlap protection

The internal logic takes care that the GL driver and GH driver are both set to LOW in this situation to avoid that $HIN = LIN = 1$ causes a cross current in the external half-bridge.

7.7 UBA2080A select function

Pin SEL enables the selection of either the UBA2080 or the UBA2081 functionality. $SEL = 0$ gives the UBA2080 functionality. $SEL = V_{DD}$ gives the UBA2081 functionality.

8. Limiting values

Table 6. Limiting values

In accordance with the Absolute Maximum Rating System (IEC 60134).

Symbol	Parameter	Conditions	Min	Max	Unit
V _{DD}	supply voltage	nominal	0	15.5	V
V _{FS}	voltage on pin FS		V _{SH}	V _{SH} + 15.5	V
V _{SH}	voltage on pin SH	source high-side MOSFET	-3	+600	V
		t < 1 μs	-14	+600	V
V _{i(HIN)}	input voltage on pin HIN	logic input for high-side driver	0	15.5	V
V _{i(LIN)}	input voltage on pin LIN	logic input for low-side driver	0	15.5	V
V _{i(SEL)}	input voltage on pin SEL		0	15.5	V
V _{CLK}	voltage on pin CLK	logic input for output drivers	0	15.5	V
V _{i(SD)}	input voltage on pin SD	logic input for output drivers and analog input for non-overlap setting	0	15.5	V
SR	slew rate	on pin SH; repetitive	-6	+6	V/ns
T _j	junction temperature		-40	+150	°C
T _{amb}	ambient temperature		-40	+150	°C
T _{stg}	storage temperature		-55	+150	°C
V _{ESD}	electrostatic discharge voltage	human body model:	[1]		
		pins FS, GH and SH	-	1	kV
		pins V _{DD} , HIN, LIN, SD, CLK, SEL	-	2	kV
		machine model:	[2]		
		all pins	-	250	V

[1] In accordance with the Human Body Model (HBM): equivalent to discharging a 100 pF capacitor through a 1.5 kΩ series resistor.

[2] In accordance with the Machine Model (MM): equivalent to discharging a 200 pF capacitor through a 1.5 kΩ series resistor and a 0.75 μH inductor.

9. Thermal characteristics

Table 7. Thermal characteristics

Symbol	Parameter	Conditions	Typ	Unit
SO8				
R _{th(j-a)}	thermal resistance from junction to ambient	in free air	[1] 160	K/W
SO14 and DIP8				
R _{th(j-a)}	thermal resistance from junction to ambient	in free air	[1] 100	K/W

[1] In accordance with IEC 60747-1.

10. Characteristics

Table 8. Characteristics

$T_j = 25\text{ °C}$; all voltages are measured with respect to SGND; $V_{DD} = 12.8\text{ V}$; positive currents flow into the IC.

Symbol	Parameter	Conditions	Min	Typ	Max	Unit
High-voltage supply						
I_{leak}	leakage current	FS = GH = SH = 600 V	-	-	10	μA
Start-up state						
I_{VDD}	current on pin V_{DD}		420	520	620	μA
$V_{DD(start)}$	start supply voltage		11	12	13	V
$V_{DD(stop)}$	stop supply voltage		8	8.5	9	V
$V_{DD(hys)}$	hysteresis of supply voltage	start-to-stop	3	3.5	4	V
Pin LIN input						
V_{IH}	HIGH-level input voltage		1.6	2.2	2.8	V
$V_{hys(LIN)}$	hysteresis voltage on pin LIN		-	400	-	mV
$I_{I(LIN)}$	input current on pin LIN		-	0	1	μA
Pin HIN input						
V_{IH}	HIGH-level input voltage		1.6	2.2	2.8	V
$V_{hys(HIN)}$	hysteresis voltage on pin HIN		-	400	-	mV
$I_{I(HIN)}$	input current on pin HIN		-	0	1	μA
Pin CLK input						
V_{IH}	HIGH-level input voltage		2.7	-	-	V
V_{IL}	LOW-level input voltage		-	-	0.8	V
$I_{I(CLK)}$	input current on pin CLK		-	0	1	μA
Pin SD input						
V_{IH}	HIGH-level input voltage	to activate shutdown	1.6	2.2	2.8	V
$V_{hys(SD)}$	hysteresis voltage on pin SD		-	400	-	mV
t_{no}	non-overlap time	$R_{SD} = 100\text{ k}\Omega$; typical minimum	-	140	-	ns
		$R_{SD} = 3\text{ M}\Omega$; typical maximum	-	2.4	-	μs
Pin SEL input						
$I_{I(SEL)}$	input current on pin SEL		-	0	1	μA
gate drivers						
$I_{O(source)}$	output source current	$V_{FS} = V_{VDD} = 12\text{ V}$; $V_{SH} = 0\text{ V}$; $V_{GH} = V_{GL} = 8\text{ V}$	-	200	-	mA
$I_{O(sink)}$	output sink current	$V_{FS} = V_{VDD} = 12\text{ V}$; $V_{SH} = 0\text{ V}$; $V_{GH} = V_{GL} = 4\text{ V}$	-	400	-	mA
$V_{d(bs)}$	bootstrap diode voltage	$I_{d(bs)} = 20\text{ mA}$	-	2.3	-	V
V_{UVLO}	undervoltage lockout voltage	reset	3.6	4.2	4.8	V
I_{FS}	current on pin FS	$V_{FS} = V_{VDD} = 12\text{ V}$; $V_{SH} = 0\text{ V}$	27	32	37	μA
Timing						
t_{PD}	propagation delay	UBA2080; matching; $C_{(GL)} = C_{(GH)} = 0$, propagation time difference between GL and GH.	-	50	-	ns

Table 8. Characteristics ...continued

$T_j = 25\text{ }^\circ\text{C}$; all voltages are measured with respect to SGND; $V_{DD} = 12.8\text{ V}$; positive currents flow into the IC.

Symbol	Parameter	Conditions	Min	Typ	Max	Unit
$t_{PD(LIN-GL)}$	propagation delay from LIN to GL	UBA2080; $C_{(GL)} = 0\text{ pF}$	-	240	-	ns
$t_{PD(HIN-GH)}$	propagation delay from HIN to GH	UBA2080; $C_{(GH)} = 0\text{ pF}$	-	180	-	ns
f_{max}	maximum frequency		800	-	-	kHz

11. Application information

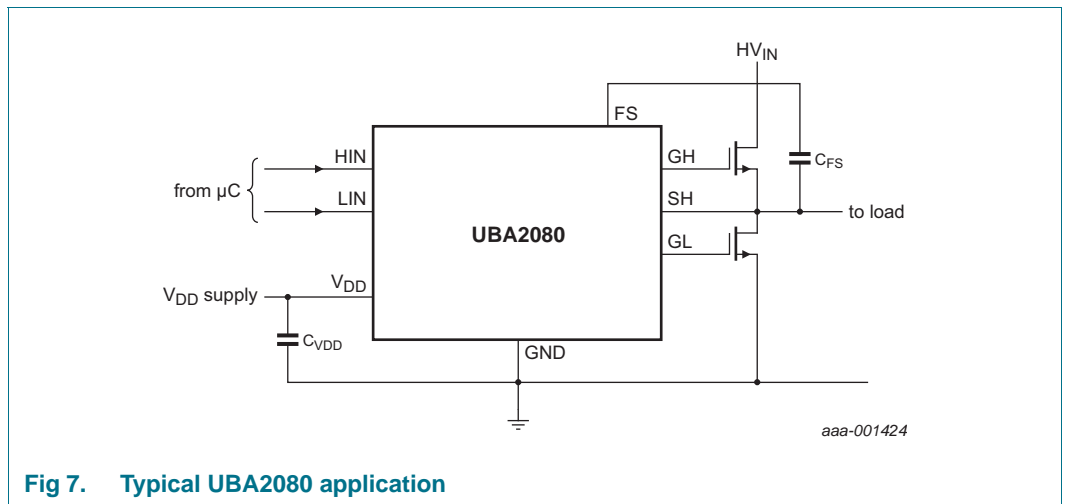

Fig 7. Typical UBA2080 application

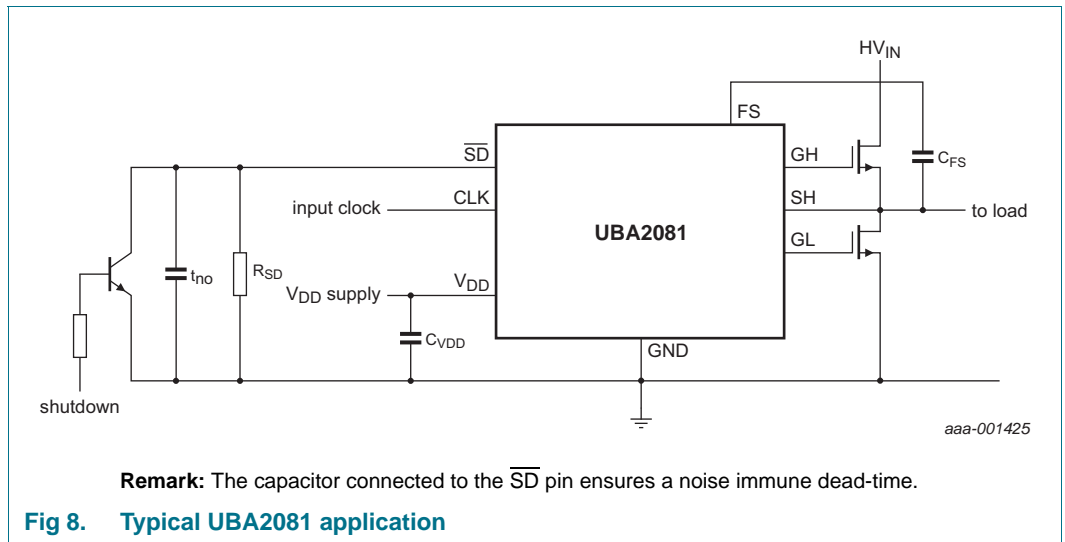

Fig 8. Typical UBA2081 application

12. Package outline

SO8: plastic small outline package; 8 leads; body width 3.9 mm

SOT96-1

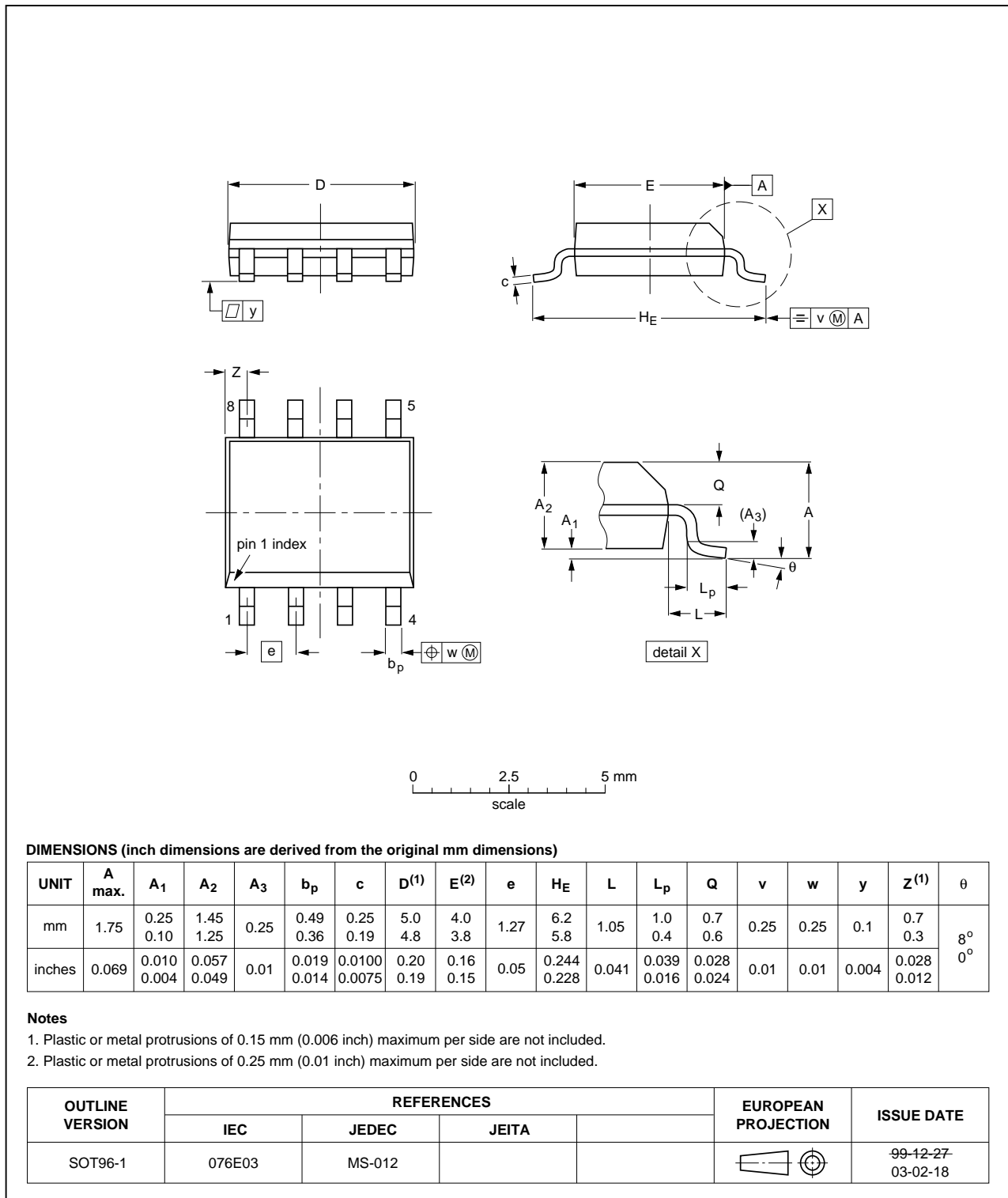

Fig 9. Package outline SOT96-1 (SO8)

DIP8: plastic dual in-line package; 8 leads (300 mil)

SOT97-1

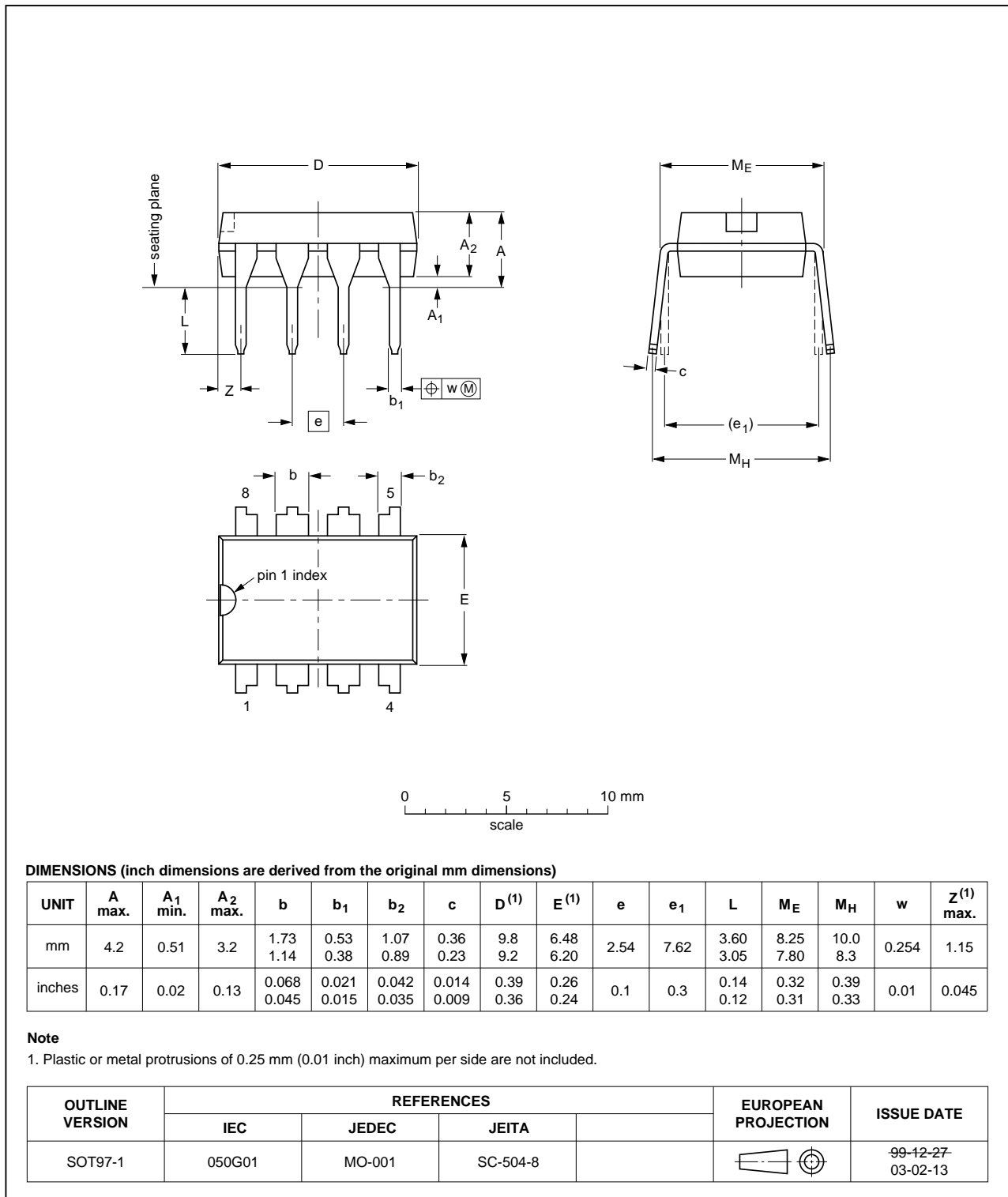

Fig 10. Package outline SOT97-1 (DIP8)

SO14: plastic small outline package; 14 leads; body width 3.9 mm

SOT108-1

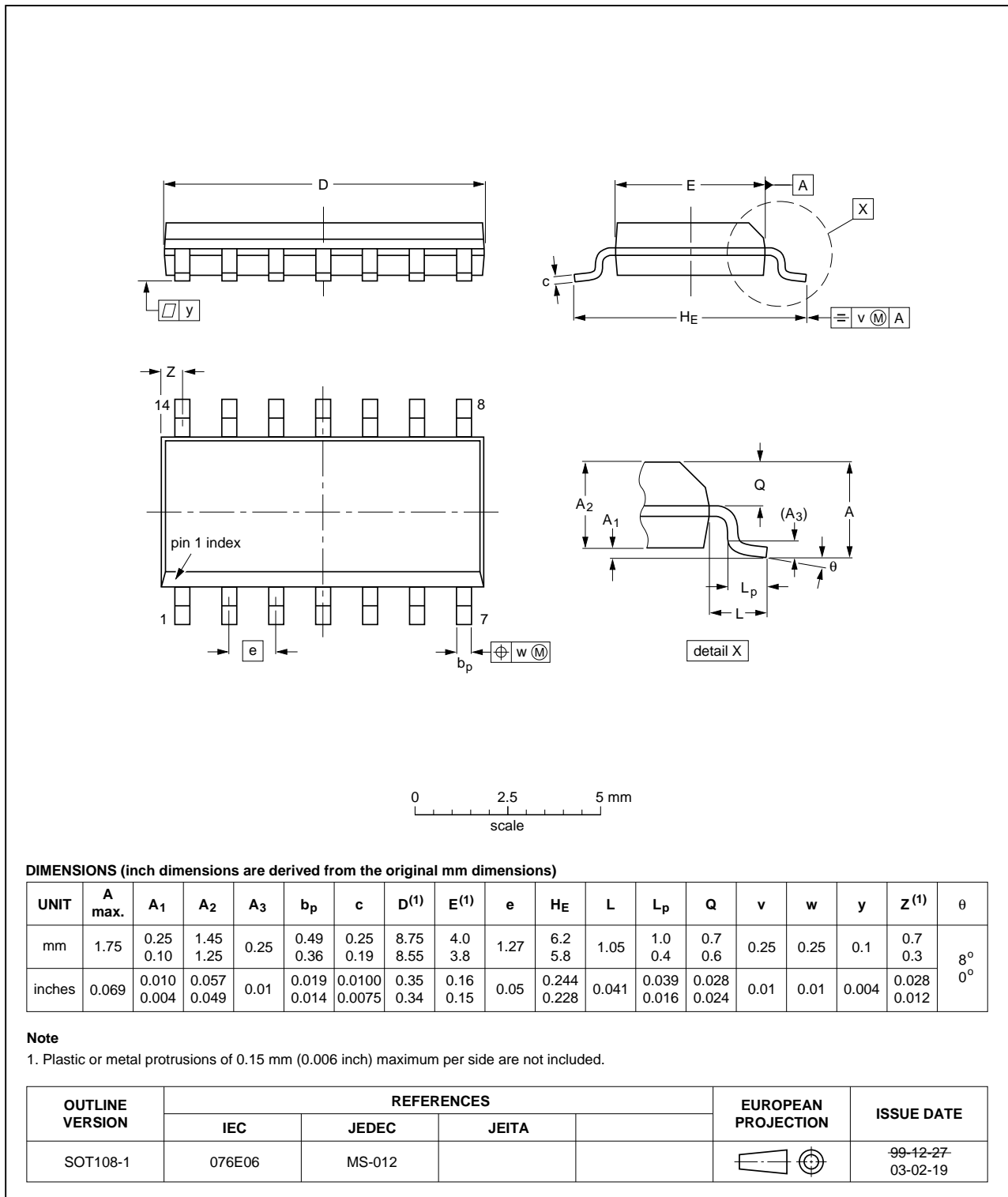

Fig 11. Package outline SOT108-1 (SO14)

13. Revision history

Table 9. Revision history

Document ID	Release date	Data sheet status	Change notice	Supersedes
UBA2080_UBA2081 v.3	20120618	Product data sheet	-	UBA2080_UBA2081 v.2
Modifications:		<ul style="list-style-type: none">Data sheet status changed from Preliminary to Product.Table 6 "Limiting values" has been updated.		
UBA2080_UBA2081 v.2	20120426	Preliminary data sheet	-	UBA2080_UBA2081 v 1.1
UBA2080_UBA2081 v.1.1	20111206	Objective data sheet	-	UBA2080_UBA2081 v.1
UBA2080_UBA2081 v.1	20111116	Objective data sheet	-	

14. Legal information

14.1 Data sheet status

Document status ^{[1][2]}	Product status ^[3]	Definition
Objective [short] data sheet	Development	This document contains data from the objective specification for product development.
Preliminary [short] data sheet	Qualification	This document contains data from the preliminary specification.
Product [short] data sheet	Production	This document contains the product specification.

[1] Please consult the most recently issued document before initiating or completing a design.

[2] The term 'short data sheet' is explained in section "Definitions".

[3] The product status of device(s) described in this document may have changed since this document was published and may differ in case of multiple devices. The latest product status information is available on the Internet at URL <http://www.nxp.com>.

14.2 Definitions

Draft — The document is a draft version only. The content is still under internal review and subject to formal approval, which may result in modifications or additions. NXP Semiconductors does not give any representations or warranties as to the accuracy or completeness of information included herein and shall have no liability for the consequences of use of such information.

Short data sheet — A short data sheet is an extract from a full data sheet with the same product type number(s) and title. A short data sheet is intended for quick reference only and should not be relied upon to contain detailed and full information. For detailed and full information see the relevant full data sheet, which is available on request via the local NXP Semiconductors sales office. In case of any inconsistency or conflict with the short data sheet, the full data sheet shall prevail.

Product specification — The information and data provided in a Product data sheet shall define the specification of the product as agreed between NXP Semiconductors and its customer, unless NXP Semiconductors and customer have explicitly agreed otherwise in writing. In no event however, shall an agreement be valid in which the NXP Semiconductors product is deemed to offer functions and qualities beyond those described in the Product data sheet.

14.3 Disclaimers

Limited warranty and liability — Information in this document is believed to be accurate and reliable. However, NXP Semiconductors does not give any representations or warranties, expressed or implied, as to the accuracy or completeness of such information and shall have no liability for the consequences of use of such information. NXP Semiconductors takes no responsibility for the content in this document if provided by an information source outside of NXP Semiconductors.

In no event shall NXP Semiconductors be liable for any indirect, incidental, punitive, special or consequential damages (including - without limitation - lost profits, lost savings, business interruption, costs related to the removal or replacement of any products or rework charges) whether or not such damages are based on tort (including negligence), warranty, breach of contract or any other legal theory.

Notwithstanding any damages that customer might incur for any reason whatsoever, NXP Semiconductors' aggregate and cumulative liability towards customer for the products described herein shall be limited in accordance with the *Terms and conditions of commercial sale* of NXP Semiconductors.

Right to make changes — NXP Semiconductors reserves the right to make changes to information published in this document, including without limitation specifications and product descriptions, at any time and without notice. This document supersedes and replaces all information supplied prior to the publication hereof.

Suitability for use — NXP Semiconductors products are not designed, authorized or warranted to be suitable for use in life support, life-critical or safety-critical systems or equipment, nor in applications where failure or malfunction of an NXP Semiconductors product can reasonably be expected to result in personal injury, death or severe property or environmental damage. NXP Semiconductors and its suppliers accept no liability for inclusion and/or use of NXP Semiconductors products in such equipment or applications and therefore such inclusion and/or use is at the customer's own risk.

Applications — Applications that are described herein for any of these products are for illustrative purposes only. NXP Semiconductors makes no representation or warranty that such applications will be suitable for the specified use without further testing or modification.

Customers are responsible for the design and operation of their applications and products using NXP Semiconductors products, and NXP Semiconductors accepts no liability for any assistance with applications or customer product design. It is customer's sole responsibility to determine whether the NXP Semiconductors product is suitable and fit for the customer's applications and products planned, as well as for the planned application and use of customer's third party customer(s). Customers should provide appropriate design and operating safeguards to minimize the risks associated with their applications and products.

NXP Semiconductors does not accept any liability related to any default, damage, costs or problem which is based on any weakness or default in the customer's applications or products, or the application or use by customer's third party customer(s). Customer is responsible for doing all necessary testing for the customer's applications and products using NXP Semiconductors products in order to avoid a default of the applications and the products or of the application or use by customer's third party customer(s). NXP does not accept any liability in this respect.

Limiting values — Stress above one or more limiting values (as defined in the Absolute Maximum Ratings System of IEC 60134) will cause permanent damage to the device. Limiting values are stress ratings only and (proper) operation of the device at these or any other conditions above those given in the Recommended operating conditions section (if present) or the Characteristics sections of this document is not warranted. Constant or repeated exposure to limiting values will permanently and irreversibly affect the quality and reliability of the device.

Terms and conditions of commercial sale — NXP Semiconductors products are sold subject to the general terms and conditions of commercial sale, as published at <http://www.nxp.com/profile/terms>, unless otherwise agreed in a valid written individual agreement. In case an individual agreement is concluded only the terms and conditions of the respective agreement shall apply. NXP Semiconductors hereby expressly objects to applying the customer's general terms and conditions with regard to the purchase of NXP Semiconductors products by customer.

No offer to sell or license — Nothing in this document may be interpreted or construed as an offer to sell products that is open for acceptance or the grant, conveyance or implication of any license under any copyrights, patents or other industrial or intellectual property rights.

Export control — This document as well as the item(s) described herein may be subject to export control regulations. Export might require a prior authorization from competent authorities.

Non-automotive qualified products — Unless this data sheet expressly states that this specific NXP Semiconductors product is automotive qualified, the product is not suitable for automotive use. It is neither qualified nor tested in accordance with automotive testing or application requirements. NXP Semiconductors accepts no liability for inclusion and/or use of non-automotive qualified products in automotive equipment or applications.

In the event that customer uses the product for design-in and use in automotive applications to automotive specifications and standards, customer (a) shall use the product without NXP Semiconductors' warranty of the

product for such automotive applications, use and specifications, and (b) whenever customer uses the product for automotive applications beyond NXP Semiconductors' specifications such use shall be solely at customer's own risk, and (c) customer fully indemnifies NXP Semiconductors for any liability, damages or failed product claims resulting from customer design and use of the product for automotive applications beyond NXP Semiconductors' standard warranty and NXP Semiconductors' product specifications.

14.4 Trademarks

Notice: All referenced brands, product names, service names and trademarks are the property of their respective owners.

15. Contact information

For more information, please visit: <http://www.nxp.com>

For sales office addresses, please send an email to: salesaddresses@nxp.com

16. Contents

1	General description	1
2	Features and benefits	1
3	Applications	1
4	Ordering information	1
5	Block diagram	2
6	Pinning information	3
6.1	Pinning	3
6.2	Pin description	3
7	Functional description	4
7.1	Start-up state	4
7.2	UBA2080 oscillation state	4
7.3	UBA2081 oscillation state	4
7.4	UBA2081 non-overlap time	5
7.5	UBA2081 shutdown protection	5
7.6	UBA2080 overlap protection	5
7.7	UBA2080A select function	5
8	Limiting values	6
9	Thermal characteristics	6
10	Characteristics	7
11	Application information	8
12	Package outline	9
13	Revision history	12
14	Legal information	13
14.1	Data sheet status	13
14.2	Definitions	13
14.3	Disclaimers	13
14.4	Trademarks	14
15	Contact information	14
16	Contents	15

Please be aware that important notices concerning this document and the product(s) described herein, have been included in section 'Legal information'.

© NXP B.V. 2012.

All rights reserved.

For more information, please visit: <http://www.nxp.com>

For sales office addresses, please send an email to: salesaddresses@nxp.com

Date of release: 18 June 2012

Document identifier: UBA2080_UBA2081