

HIGH-VOLTAGE MIXED-SIGNAL IC

UC1608

128COM x 240SEG Matrix LCD Controller-Driver

DataSheet4U.com

DataShee

Product Specification
Revision 0.52 Preview

July 24, 2002

ULTRACHIP

The Coolest LCD Driver Ever!!

UC1608

128x240 Matrix LCD Controller-Drivers

Table Of Revision History

Version	Contents	Date of revision
0.52	First release	July 24,2002

Table of Content

Introduction	1
Ordering Information	2
Block Diagram.....	3
Pin Description.....	4
Control Registers	7
Command Summary	9
Command description	10
LCD Voltage Setting	15
V _{LCD} Quick Reference	16
LCD Display Controls.....	17
Host Interface	19
Display Data RAM.....	20
Reset & Power Management	23
Absolute Maximum Ratings	27
Specifications.....	28
AC Characteristics	29
Physical Dimensions.....	32
Pad Coordinates	33

UC1608

*Single-Chip, Ultra-Low Power
128COM x 240SEG Matrix
Passive LCD Controller-Driver*

INTRODUCTION

UC1608 is an advanced high-voltage mixed-signal CMOS IC, especially designed for the display needs of ultra-low power hand-held devices.

This chip employs UltraChip's unique DCC (Direct Capacitor Coupling) driver architecture to achieve near crosstalk free images.

In addition to low power COM and SEG drivers, UC1608 contains all necessary circuits for high-V LCD power supply, bias voltage generation, timing generation and graphics data memory.

Advanced circuit design techniques are employed to minimize external component counts and reduce connector size while achieving extremely low power consumption.

MAIN APPLICATIONS

- Cellular Phones, Smart Phones, PDA and other battery operated palm top devices and/or portable Instruments

FEATURE HIGHLIGHTS

- Single chip controller-driver supports 128 COM x 240 SEG LCD, with vertical scroll.

- Support industry standard 8080 or 6800 bus protocol in either 8-bit or 4-bit parallel interface.
- Support two multiplexing rates (128, 96).
- Self-configuring 8x charge pump with on-chip pumping capacitor requires only 5 external capacitors to operate.
- Flexible data addressing/mapping schemes to support wide ranges of software models and LCD layout placements.
- Software programmable 4 temperature compensation coefficients.
- On-chip bypass capacitor for V_{LCD} makes V_{LCD} bypass capacitor optional for small LCD panels.
- On-chip Power-ON Reset and Software RESET commands, make RST pin optional.
- V_{DD} (digital) range: 2.4V ~ 3.3V
 V_{DD} (analog) range: 2.4V ~ 3.3V
LCD V_{OP} range: 6.5V ~ 15V
- Available in gold bump dies
Bump pitch: 50uM min.
Bump gap: 18uM min.

ULTRACHIP

High-Voltage Mixed-Signal IC

©1999-2002

ORDERING INFORMATION

Product ID	Description
UC1608xGAC	Gold bumped die.
UC1608xFAC	COF packaging.

General Notes

DataSheet4U.com

APPLICATION INFORMATION

For improved readability, the specification contains many application data points. When application information is given, it is advisory and does not form part of the specification for the device.

BARE DIE DISCLAIMER

All die are tested and are guaranteed to comply with all data sheet limits up to the point of wafer sawing for a period of ninety (90) days from the date of UltraChip's delivery. There is no post wafer saw/pack testing performed on individual die. Although the latest modern processes are utilized for wafer sawing and die pick-&-place into wafer pack carriers, UltraChip has no control of third party procedures in the handling, packing or assembly of the die. Accordingly, it is the responsibility of the customer to test and qualify their application in which the die is to be used. UltraChip assumes no liability for device functionality or performance of the die or systems after handling, packing or assembly of the die.

LIFE SUPPORT APPLICATIONS

These devices are not designed for use in life support appliances, or systems where malfunction of these products can reasonably be expected to result in personal injuries. Customer using or selling these products for use in such applications do so at their own risk.

BLOCK DIAGRAM

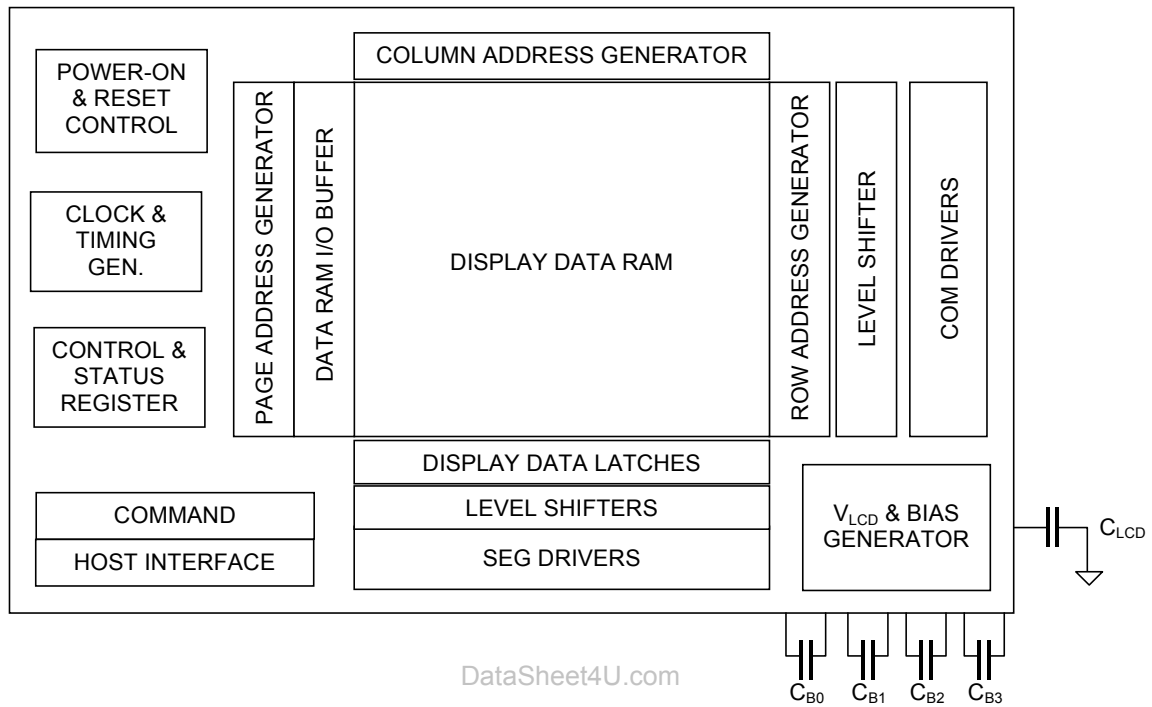

ULTRACHIP

High-Voltage Mixed-Signal IC

©1999-2002

PIN DESCRIPTION

Name	Type	Pins	Description
MAIN POWER SUPPLY			
V _{DD} V _{DD2} V _{DD3}	PWR		V _{DD2} /V _{DD3} is the analog V _{DD} and it should be connected to the same power source. V _{DD} is the digital V _{DD} and is connected to a voltage source that is the same, or lower than V _{DD2} /V _{DD3} . V _{DD} supplies for digital logic and display data RAM. V _{DD2} supplies for V _{LCD} and V _{BIAS} generator, V _{DD3} supplies for other analog circuits. Minimize the trace resistance for V _{DD} and V _{DD2} .
V _{SS} V _{SS2}	GND		Ground. Connect V _{SS} and V _{SS2} to the shared GND pin. Minimize the trace resistance for V _{SS} and V _{SS2} .
LCD POWER SUPPLY			
V _{B3+} V _{B3-} V _{B2+} V _{B2-} V _{B1+} V _{B1-} V _{B0+} V _{B0-}	PWR		LCD Bias Voltages. These are the voltage source to provide SEG driving currents. These voltages are generated internally. Connect capacitors of C _{BX} value between V _{BX+} and V _{BX-} . The resistance of these four traces directly affects the SEG driving strength of the resulting LCD module. Minimize the trace resistance is critical in achieving high quality image.
S _{B3+} S _{B3-} S _{B2+} S _{B2-} S _{B1+} S _{B1-} S _{B0+} S _{B0-}	I		The sensor pins for C _{BX} capacitors. Please connect these sensor pins as closely to proper C _{BX} pads as possible. These signals can tolerate input resistance of up to 2K Ohm, so, narrow COF traces can be used. However, the noise on these pins affects the accuracy of SEG driving voltage level. To minimize noise caused by V _{BX-} -C _{BX} charging current, the trace resistance shared between V _{BX+/-} and S _{BX+/-} should be minimized.
V _{LCD-IN} V _{LCD-OUT}	PWR		Main LCD Power Supply. Connect these pins together. A by-pass capacitor C _L is optional. When C _L is used, connect C _L between V _{LCD} and V _{SS} , and keep the trace resistance under 300 Ohm.

NOTE

- Recommended capacitor values:
C_B: ~100x LCD load capacitance or 1.5uF (2V), whichever is higher.
C_L: 10nF ~ 50nF (16V) is appropriate for most applications.

Name	Type	Pins	Description
HOST INTERFACE			
BM[1:0]	I		Parallel/Serial. 4-bit bus modes: "LL": 8080 "LH": 6800 8-bit bus modes: "HL": 8080 "HH": 6800
CS	I		Chip Select. The chip is selected when CS="H". When the chip is not selected, D[7:0] will be high impedance.
RST	I		When RST="L", all control registers are re-initialized by their default states. Since UC1608 has built-in Power-ON-Reset and Software Reset command, RST pin is not required for proper chip operation. When RST pin is used, insert a 5~10K Ohm resistor to improve noise filtering. When RST is not used, connect the pin to V _{DD} .
CD	I		Select Command or Display Data for read/write operation. "L": Command "H": Display data
WR0 WR1	I		WR[1:0] controls the read/write operation of the host interface. In parallel mode, WR[1:0] meaning depends on whether the interface is in the 6800 mode or the 8080 mode.
D0~D7	I/O		Bi-directional bus for both serial and parallel host interfaces. In 4-bit bus mode, connect unused pins to V _{DD} or V _{SS} .

ULTRACHIP

High-Voltage Mixed-Signal IC

©1999-2002

Name	Type	Pins	Description
LCD DRIVER OUTPUT			
SEG1 ~ SEG240	HV		SEG (column) driver outputs. Support up to 240 columns. Leave unused drivers open-circuit.
COM1 ~ COM128	HV		COM (row) driver outputs. Support up to 128 rows. When Mux Rate is not 128, please use only COM1~COM(x), x=128, or 96, and leave COM (x+1) ~ COM128 open-circuit.
MISC. PINS			
TST4	I		Test control. Connect to V _{SS} .
TST[3:1]	I/O		Test I/O pins. Leave these pins open circuit during normal use.
TP[3:1]	I		Test control. Leave these pins open circuit during normal use.

CONTROL REGISTERS

UC1608 contains registers which control the chip operation. These registers can be modified by commands. The following table is a summary of the control registers, their meaning and their default value. The commands supported by UC1608 are described in the next two sections, first a summary table, followed by a detailed description.

Name: The Symbolic reference of the register byte.
Note that, some symbol names refer to collection of bits (flags) within one register byte.

Default: Numbers shown in **Bold** fonts are values after *Power-Up-Reset* and *System-Reset*..

Name	Bits	Default	Description
SL	6	0H	Start Line. Mapping from COM1 to Display Data RAM.
CR	8	0H	Return Column Address. Useful for cursor implementation.
CA	8	0H	Display Data RAM Column Address (Used in Host to Display Data RAM access)
PA	4	0H	Display Data RAM Page Address (Used in Host to Display Data RAM access)
BR	2	2H	Bias Ratio. The ratio between V_{LCD} and V_{BIAS} . 00b= 10.7 01b= 11.3 10b=12.0 11b= 12.7
TC	2	0H	Temperature Compensation (per °C). 00b: 0.0% 01b: -0.05% 10b: -0.1% 11b: -0.2%
GN	2	3H	Gain, coarse setting of V_{BIAS} and V_{LCD}
PM	6	0H	Electronic Potentiometer to fine tune V_{BIAS} and V_{LCD}
MR	1	1H	Multiplexing Rate: Number of pixel rows: 0b: 96 1b: 128
OM	2	–	Operating Modes (Read Only) 10b: Sleep 11b: Normal 01b: (Not used) 00b: Reset
BZ	1	–	Busy with internal processes (reset, changing mode, etc.) OK for Display RAM read/write access.
RS	1	–	Reset in progress, Host Interface not ready
PC	3	7H	Power Control and panel loading. PC[0]: 0b: LCD: <20nF 1b: LCD: >20nF PC[2:1]: 00b: External V_{LCD} 11b: Internal V_{LCD} 01b and 10b are reserved, for UltraChip only. Please do not use.
APC0	8	2CH	Advanced Product Configuration. For UltraChip only. Please do not use.

ULTRACHIP

High-Voltage Mixed-Signal IC

©1999-2002

Name	Bits	Default	Description
DC	3	00H	Display Control: DC[0]: PXV: Pixels Inverse (Default OFF) DC[1]: APO: All Pixels ON (Default OFF) DC[2]: Display ON/OFF (Default OFF).
AC	4	0H	Address Control: AC[0]: WA: Automatic column/page Wrap Around (Default 0:OFF) AC[1]: Reserved (always set to 0) AC[2]: PID: PA (page address) auto increment direction (0: +1 1: -1) AC[3]: CUM: Cursor update mode, (Default 0:OFF) when CUM=1, CA increment on write only, wrap around suspended
LC	4	00H	LCD Mapping Control: LC[0]: MSF: MSB First mapping Option LC[1]: Reserved (always set to 0) LC[2]: MX, Mirror X (Column sequence inversion) LC[3]: MY, Mirror Y (Row sequence inversion)

COMMAND SUMMARY

The following is a list of host commands supported by UC1608

C/D: 0: Control, 1: Data
 W/R: 0: Write Cycle, 1: Read Cycle
 # Useful Data bits
 - Don't Care

	Command	C/D	W/R	D7	D6	D5	D4	D3	D2	D1	D0	Action	Default value
1	Write Data Byte	1	0	#	#	#	#	#	#	#	#	Write 1 byte	N/A
2	Read Data Byte	1	1	#	#	#	#	#	#	#	#	Read 1 byte	N/A
3	Get Status	0	1	BZ	MX	DE	RS	WA	GN1	GN0	1	Get Status	N/A
4	Set Column Address LSB	0	0	0	0	0	0	#	#	#	#	Set CA[3:0]	0
	Set Column Address MSB	0	0	0	0	0	1	#	#	#	#	Set CA[7:4]	0
5	Set Mux Rate and temperature compensation.	0	0	0	0	1	0	0	#	#	#	Set {MR, TC[1:0]}	MR: 1 TC: 0
6	Set Power Control	0	0	0	0	1	0	1	#	#	#	Set PC[2:0]	111b
7	Set Adv. Product Config. (double byte command)	0	0	0	0	1	1	0	0	0	R	For UltraChip only. Do not use.	N/A
		0	0	#	#	#	#	#	#	#	#		
8	Set Start Line	0	0	0	1	#	#	#	#	#	#	Set SL[5:0]	0
9	Set Gain and Potentiometer (double-byte command)	0	0	1	0	0	0	0	0	0	1	Set {GN[1:0], PM[5:0]}	GN=3 PM=0
		0	0	#	#	#	#	#	#	#	#		
10	Set RAM Address Control	0	0	1	0	0	0	1	#	#	#	Set AC[2:0]	000b
11	Set All-Pixel-ON	0	0	1	0	1	0	0	1	0	#	Set DC[1]	0=disable
12	Set Inverse Display	0	0	1	0	1	0	0	1	1	#	Set DC[0]	0=disable
13	Set Display Enable	0	0	1	0	1	0	1	1	1	#	Set DC[2]	0=disable
14	Set Page Address	0	0	1	0	1	1	#	#	#	#	Set PA[3:0]	0
15	Set LCD Mapping Control	0	0	1	1	0	0	#	#	#	#	Set LC[3:0]	0
16	System Reset	0	0	1	1	1	0	0	0	1	0	System Reset	N/A
17	NOP	0	0	1	1	1	0	0	0	1	1	No operation	N/A
18	Set LCD Bias Ratio	0	0	1	1	1	0	1	0	#	#	Set BR[1:0]	10b=12
19	Reset Cursor Mode	0	0	1	1	1	0	1	1	1	0	AC[3]=0, CA=CR	N/A
20	Set Cursor Mode	0	0	1	1	1	0	1	1	1	1	AC[3]=1, CR=CA	N/A
21	Set Test Control (double byte command)	0	0	1	1	1	0	0	1	TT		For UltraChip only. Do not use.	N/A
		0	0	#	#	#	#	#	#	#	#		

* Other than commands listed above, all other bit patterns may result in undefined behavior.

COMMAND DESCRIPTION**(1) Write data to display memory**

Action	C/D	W/R	D7	D6	D5	D4	D3	D2	D1	D0
Write data	1	0	8bits data write to SRAM							

(2) Read data to display memory

Action	C/D	W/R	D7	D6	D5	D4	D3	D2	D1	D0
Read data	1	1	8bits data from SRAM							

Write/Read Data Byte (command 1,2) operations access display buffer RAM based on Page Address (PA) register and Column Address (CA) register. To minimize bus interface cycles, PA and CA will be incremented automatically depending on the setting of Access Control (AC) registers. PA and CA can also be programmed directly by issuing *Set Page Address* and *Set Column Address* commands.

If Wrap-Around (WA) is OFF (AC[0] = 0), CA will stop increasing after reaching the end of page (MC), and system programmers need to set the values of PA and CA explicitly. If WA is ON (AC[0]=1), when CA reaches end of page, CA will be reset to 0 and PA will be increased or decrease by 1, depending on the setting of Page Increment Direction (PID, AC[2]). When PA reaches the boundary of RAM (i.e. PA = 0 or 15), PA will be wrapped around to the other end of RAM and continue.

(3) Get Status

Action	C/D	W/R	D7	D6	D5	D4	D3	D2	D1	D0
Get Status	0	1	BZ	MX	DE	RS	WA	GN1	GN0	1

Status flag definitions:

BZ: Busy with internal process. When BZ=1 host interface can access if RS=0.

MX: Status of register LC[1], mirror X.

DE: Display enable flag. DE=1 when display enabled

RS: Reset in progress. If RS=1, host interface will be inaccessible.

WA: status of register AC[0] .automatic column/page wrap around.

GN0,1:GN[1:0] .register Gain

(4) Set Column Address

Action	C/D	W/R	D7	D6	D5	D4	D3	D2	D1	D0
Set Column Address LSB CA[3:0]	0	0	0	0	0	0	CA3	CA2	CA1	CA0
Set Column Address MSB CA[7:4]	0	0	0	0	0	1	CA7	CA6	CA5	CA4

Set the SRAM column address before Write/Read memory from host interface.

CA possible value=**0-239**

(5) Set Multiplex Rate and Temperature Compensation

Action	C/D	W/R	D7	D6	D5	D4	D3	D2	D1	D0
Set Multiplex Rate MR	0	0	0	0	1	0	0	MR	TC1	TC0
Set Temperature Compensation TC[1:0]	0	0	0	0	1	0	0	MR	TC1	TC0

Set the multiplex ratio (number of rows) and temperature compensation.

MUX ratio definition: **0b**=96 **1b**=128

Temperature compensation curve definition:

00b= -0.00%/C **01b**= -0.05%/C **10b**= -0.10%/C **11b**= -0.20%/C

(6) Set Power Control

Action	C/D	W/R	D7	D6	D5	D4	D3	D2	D1	D0
Set Panel Loading PC[2:0]	0	0	0	0	1	0	1	PC2	PC1	PC0

Set PC[0] according to the capacitance loading of LCD panel.

0b: <=20nF **1b**: >20nF

Set PC[2:1] to program to use internal charge pump of external VLCD source:

00b=External VLCD **11b**=Internal VLCD

(7) Set Advance Product Configuration

Action	C/D	W/R	D7	D6	D5	D4	D3	D2	D1	D0
Set APC	0	0	0	0	1	1	0	0	0	R
(Double byte command)	0	0	APC register parameter							

For UltraChip only. Please Do NOT use.

(8) Set Start Line

Action	C/D	W/R	D7	D6	D5	D4	D3	D2	D1	D0
Set Start Line SL[5:0]	0	0	0	1	SL5	SL4	SL3	SL2	SL1	SL0

Set the start line number

Start line setting will scroll the displayed image up by SL rows. The valid value is between 0 (no scrolling) and 63. One example of the visual effect on LCD is illustrated in the figure below.

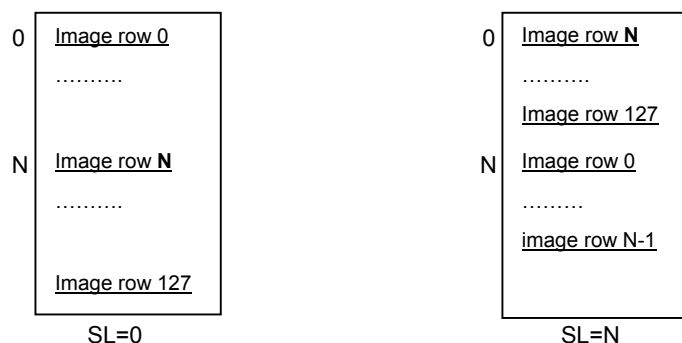

ULTRACHIP

High-Voltage Mixed-Signal IC

©1999-2002

(9) Set Gain and Potentiometer

Action	C/D	W/R	D7	D6	D5	D4	D3	D2	D1	D0
Set Gain and Potentiometer GN [1:0] PM [5:0] (Double byte command)	0	0	1	0	0	0	0	0	0	1
	0	0	GN1	GN0	PM5	PM4	PM3	PM2	PM1	PM0

Program Gain (GN[1:0]) and Potentiometer (PM[5:0]). See section LCD VOLTAGE SETTING for more detail.

Effective range of GN = 0 ~ 3 PM value = 0 ~ 63

(10) Set RAM Address Control

Action	C/D	W/R	D7	D6	D5	D4	D3	D2	D1	D0
Set AC [2:0]	0	0	1	0	0	0	1	AC2	AC1	AC0

Program registers AC[2:0] for RAM address control.

AC[0] - WA, Automatic column/page wrap around.

0: CA or PA (depends on AC[1]= 0 or 1) will stop incrementing after reaching boundary

1: CA or PA (depends on AC[1]= 0 or 1) will restart, and PA or CA will increment by one step.

AC[1] – Auto-Increment order

0 : column (CA) increment (+1) first until CA reach CA boundary, then PA will increment by (+/-1).

1 : page (PA) increment (+/-1) first until PA reach PA boundary, then CA will increment by (+1) .

AC[2] – PID, page address (PA) auto increment direction (0/1 = +/- 1)

When WA=1, controls whether page address will be adjusted by +1 or -1, when CA reached CA boundary. No effect when WA=0.

CA boundary is 240 and PA boundary is 15 when PID=0, PA boundary is 0 when PID=1.

(11) Set All Pixel ON

Action	C/D	W/R	D7	D6	D5	D4	D3	D2	D1	D0
Set All Pixel On DC [1]	0	0	1	0	1	0	0	1	0	DC1

Set DC[1] to force all SEG drivers to output ON signals. This function has no effect on the existing data stored in display RAM.

(12) Set Inverse Display

Action	C/D	W/R	D7	D6	D5	D4	D3	D2	D1	D0
Set Inverse Display DC [0]	0	0	1	0	1	0	0	1	1	DC0

Set DC[0] to force all SEG drivers to output the inverse of the data stored in display memory. This function has no effect on the existing data stored in display RAM.

(13) Set Display Enable

Action	C/D	W/R	D7	D6	D5	D4	D3	D2	D1	D0
Set Display Enable DC[2]	0	0	1	0	1	0	1	1	1	DC2

This command is for programming registers DC[2].

When DC[2] is set to 0, the IC will put itself into Sleep mode. All drivers, voltage generation circuit and timing circuit will be halted to conserve power. When DC[2] is set to 1, UC1608 will first exit from Sleep mode, restore the power and then turn on COM drivers and SEG drivers. There is no other explicit user action or timing sequence required to enter or exit the Sleep mode.

(14) Set Page Address

Action	C/D	W/R	D7	D6	D5	D4	D3	D2	D1	D0
Set Page Address LSB PA [3:0]	0	0	1	0	1	1	PA3	PA2	PA1	PA0

Set the SRAM page address before write/read memory from host interface.

Effective range of value = 0 ~ 15

(15) Set LCD Mapping Control

Action	C/D	W/R	D7	D6	D5	D4	D3	D2	D1	D0
Set LCD Mapping Control LC[3:0]	0	0	1	1	0	0	MY	MX	-	MSF

Set LC[3:0] for COM (row) mirror (MY), SEG (column) mirror (MX) and MSB first or LSB first options (MSF).

MY is implemented by reversing the mapping order between RAM and COM (row) electrodes. The data stored in RAM is not affected by MY command. MY will have immediate effect on the display image.

MX is implemented by selecting the CA or 239-CA as write/read (from host interface) display RAM column address so this function will only take effect after rewriting the RAM data

MSF is implemented by MSB-LSB swapping. When MSB first (LC[0]) bit is set, data D[7:0] will be realigned as D[0:7] then be stored to RAM.

(16) System Reset

Action	C/D	W/R	D7	D6	D5	D4	D3	D2	D1	D0
System Reset	0	0	1	1	1	0	0	0	1	0

This command will activate the system reset. The system will take about 5ms to reset

(17) NOP

Action	C/D	W/R	D7	D6	D5	D4	D3	D2	D1	D0
No operation	0	0	1	1	1	0	0	0	1	1

This command is used for "no operation".

(18) Set LCD Bias Ratio

Action	C/D	W/R	D7	D6	D5	D4	D3	D2	D1	D0
Set Bias Ratio BR [1:0]	0	0	1	1	1	0	1	0	BR1	BR0

Bias ratio definition:

00b= 10.7

01b=11.3

10b=12.0

11b=12.7

(19) Reset Cursor Mode

Action	C/D	W/R	D7	D6	D5	D4	D3	D2	D1	D0
Return to Cursor. AC[3]=0, CA=CR	0	0	1	1	1	0	1	1	1	0

This command is used to reset cursor update mode function. See description below.

(20) Set Cursor Mode

Action	C/D	W/R	D7	D6	D5	D4	D3	D2	D1	D0
Set AC[3]=1 CR=CA	0	0	1	1	1	0	1	1	1	1

Set Cursor Mode command is used to turn on cursor update mode function. AC[3] will be set to 1, register CR will be set to the value of register CA

When AC[3]=1, column address (CA) will only increment with write RAM operation but not on read RAM operation. The address CA wraps around will also be suspended no matter what WA setting is. The purpose of this combination of features is to support "Read-Modify-Write" for cursor implementation.

Reset Cursor Mode command will clear cursor update mode flag (AC[3]=0), CA will be restored to previous CA value which is stored in CR, and CA, PA increment will return to its normal condition.

(21) Set Test Control

Action	C/D	W/R	D7	D6	D5	D4	D3	D2	D1	D0
Set TT	0	0	1	1	1	0	0	1	TT	
(Double byte command)	0	0	Testing parameter							

This command is used for UltraChip production testing. For UltraChip Only. Please do not use.

LCD VOLTAGE SETTING

MULTIPLEX RATES

Multiplex Rates (*MR*) is software programmable. Two MR is supported: 96, 128.

BIAS RATIO SELECTION

Bias Ratio (*BR*) is defined as the ratio between V_{LCD} and V_{BIAS} , i.e.

$$BR = V_{LCD} / V_{BIAS},$$

where $V_{BIAS} = V_{B1+} - V_{B1-} = V_{B0+} - V_{B0-}$.

The theoretical optimum *Bias Ratio* can be estimated by $\sqrt{Mux} + 1$. In some applications, *BR* is set to be 10~15% lower than the optimum value calculated above in order to lower V_{LCD} by 5~6%. Such setting generally will not cause visible change in image quality.

UC1608 supports four *BR* as listed below. *BR* can be selected by software program.

BR	0	1	2	3
Bias Ratio	10.7	11.3	12	12.7

Table 2: Bias Ratios

TEMPERATURE COMPENSATION

Four (4) different temperature compensation coefficients can be selected via software. The four coefficients are given below:

TC	0	1	2	3
% per °C	0.0	-0.05	-0.10	-0.20

Table 4: Temperature Compensation

V_{LCD} GENERATION

V_{LCD} may be supplied either by internal charge pump or by external power supply. The source of V_{LCD} is controlled by PC[2:1]. For good product performance it is recommended to keep V_{LCD} under 13V at room temperature.

When V_{LCD} is generated internally, the voltage level of V_{LCD} is determined by four control registers: *BR* (Bias Ratio), *GN* (Gain), *PM* (Potentiometer), and *TC* (Temperature Compensation), with the following relationship:

$$V_{LCD} = (C_{V0} + C_{PM} \times PM) \times (1 + (T - 25) \times C_T \%)$$

where

C_{V0} and C_{PM} are two constants, whose value depends on the BR-GN register setting. The values are provided in the table on the next page,

PM is the numerical value of PM register,

T is the ambient temperature in °C, and

C_T is the temperature compensation coefficient as selected by TC register.

LOAD DRIVING STRENGTH

The power supply circuit of UC1608 is designed to handle LCD panels with load capacitance up to ~20nF when $V_{DD2} = 2.5V$. For larger LCD panels use higher V_{DD} and COF packaging.

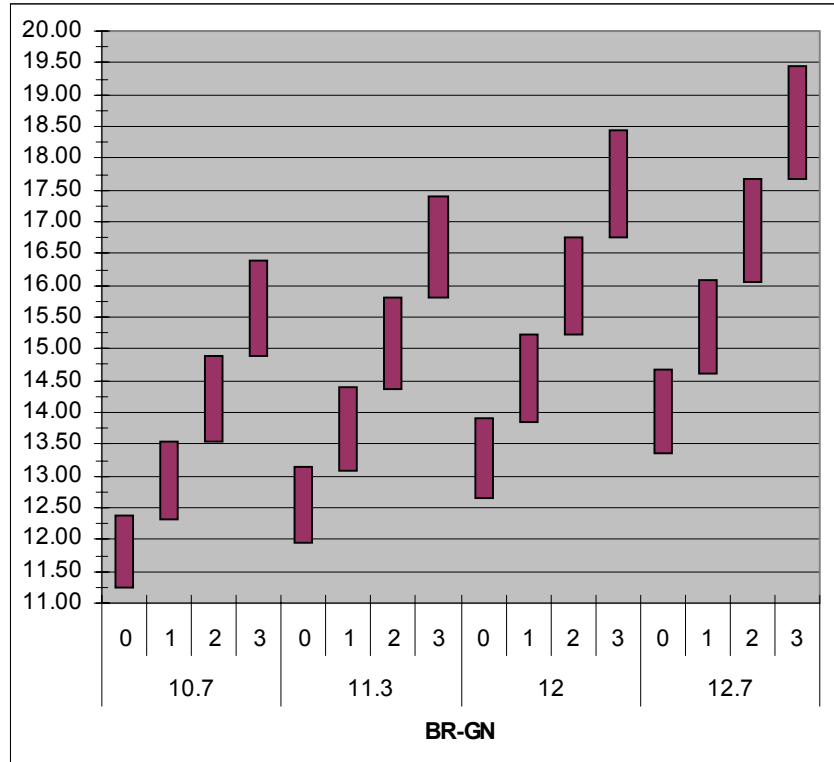
V_{LCD} QUICK REFERENCE

BR	GN	C _{v0} (V)	C _{PM} (mV)	V _{LCD} Range (V)	
10.7	0	11.240	17.90	11.240	12.368
	1	12.304	19.59	12.304	13.538
	2	13.527	21.54	13.527	14.884
	3	14.888	23.71	14.888	16.381
11.3	0	11.943	19.02	11.943	13.141
	1	13.073	20.82	13.073	14.384
	2	14.372	22.89	14.372	15.814
	3	15.818	25.19	15.818	17.405
12	0	12.645	20.14	12.645	13.914
	1	13.842	22.04	13.842	15.230
	2	15.217	24.23	15.217	16.744
	3	16.749	26.67	16.749	18.429
12.7	0	13.348	21.25	13.348	14.687
	1	14.611	23.27	14.611	16.076
	2	16.063	25.58	16.063	17.674
	3	17.679	28.15	17.679	19.453

Note: For best product reliability keep V_{LCD} under **15.5V** under all temperature.

LCD DISPLAY CONTROLS

CLOCK & TIMING GENERATOR

UC1608 contains a built-in system clock. All required components for the clock oscillator are built-in. No external parts are required.

DRIVER MODES

COM and SEG drivers can be in either Idle mode or Active mode, controlled by Display Enable flag (DC[2]). When COM drivers are in idle mode, their outputs are high-impedance (open circuit). When SEG drivers are in idle mode, their outputs are connected to V_{SS} .

DRIVER ARRANGEMENTS

The naming conventions are: COM(x), where $x=1\sim 128$, refers to the COM driver for the x-th row of pixels on the LCD panel.

The mapping of COM(x) to LCD pixel rows is the same for all MR, MX and MY settings. When MR is not 128, then COM(x) ~ COM128 ($X = MR+1$) should be left open circuit.

DISPLAY CONTROLS

There are three groups of display control flags in the control register DC: Driver Enable (DE), All-Pixel-ON (APO) and Inverse (PXV). DE has the overriding effect over PXV and APO.

DRIVER ENABLE (DE)

Driver Enable is controlled by the value of DC[2]. When DE is set to OFF (logic "0"), both SEG and COM drivers will become idle and UC1608 will put itself into Sleep mode to conserve power.

When DE is set to ON, UC1608 will first exit from Sleep mode, restore the power (V_{LCD} , V_{BIAS} etc.) and then turn on COM and SEG drivers.

ALL PIXELS ON (APO)

When set, this flag will force all active SEG drivers to output On signals, disregarding the data stored in the display buffer.

This flag has no effect when Display Enable is OFF and it has no effect on data stored in RAM.

INVERSE (PXV)

When this flag is set to ON, active SEG drivers will output the inverse of the value it received from the display buffer RAM (bit-wise inversion). This flag has no impact on data stored in RAM.

SCROLLING

SL register can be used to implement scroll function. Setting SL to a non-zero value N will result in the image being scrolled by N lines.

ITO LAYOUT CONSIDERATIONS FOR COM SIGNALS

Since UC1608 line rate is as fast as 10KHz and the common scanning pulse is only 100us wide, it is critical to minimize the RC delay experienced by common electrodes.

It is recommended to optimize the ITO layout to limit the worst case common electrode RC delay as calculated below:

$$(R_{ROW}/3 + R_{COM} + R_{OUT}) \times C_{ROW} < 2\mu S$$

where

- C_{ROW} : LCD loading capacitance of one row of pixels.
- R_{ROW} : ITO resistance over one row of pixels within the active area
- R_{COM} : ITO resistance leading from COF OLD to the active area
- R_{OUT} : UC1608 output, 1.5K Ohm typical

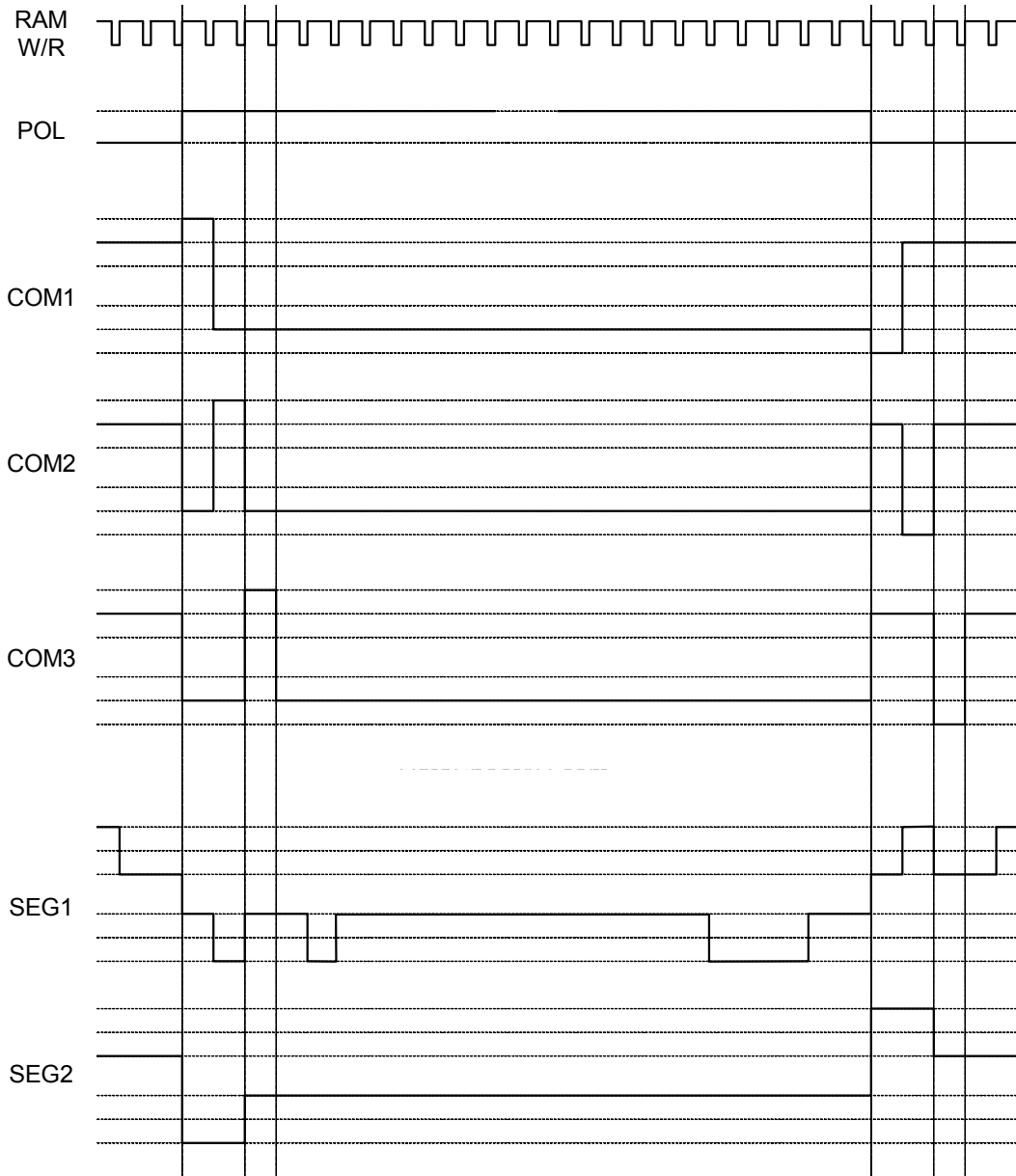

Fig. 4 COM and SEG Driving Waveform

HOST INTERFACE

As summarized in the table below, UC1608 supports two parallel bus protocols, in either 8-bit or 4-bit bus width.

Designers can either use parallel bus to achieve high data transfer rate.

Bus Type		8080		6800	
Width		8-bit	4-bit	8-bit	4-bit
Access		Read/Write			
Control Pins & Data Pins	BM[1:0]	10	00	11	01
	WR0	\overline{WR}		R/ \overline{W}	
	WR1	\overline{RD}		EN	
	D[7:4]	Data	–	Data	–
	D[3:0]	Data	Data	Data	Data

* Connect unused control pins and data bus pins to V_{DD} or V_{SS}

Table 5: Host interfaces Choices

PARALLEL INTERFACE

The timing relationship between UC1608 internal control signal RD, WR and their associated bus actions are shown in the figure below.

The Display RAM read interface is implemented as a two-stage pipe-line. This architecture requires that, every time memory address is modified, either in 8-bit mode or 4-bit mode, by either *Set CA*, or *Set PA* command, a dummy read cycle need to be performed before the actual data can propagate through the pipe-line and be read from data port D[7:0].

There is no pipeline in write interface of Display RAM. Data is transferred directly from bus buffer to internal RAM on the rising edges of write pulses.

8-BIT & 4-BIT BUS OPERATION

UC1608 supports both 8-bit and 4-bit bus width. The bus width is determined by pin BM[1].

4-bit bus operation exactly doubles the clock cycles of 8-bit bus operation, MSB followed by LSB, including the dummy read, which also requires two clock cycles.

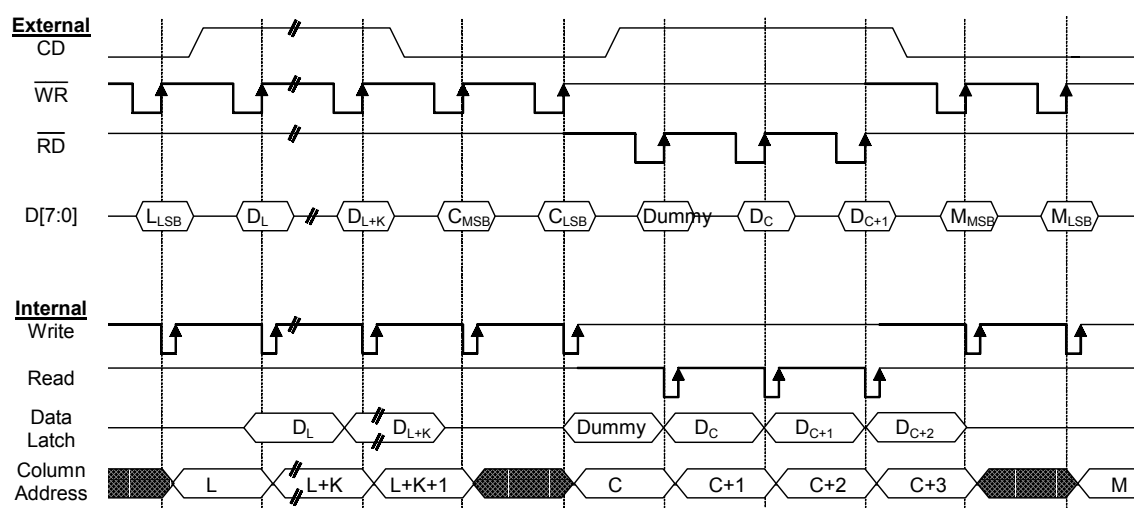

Figure 5: 8 bit Parallel Interface & Related Internal Signals

DISPLAY DATA RAM

DATA ORGANIZATION

The display data is 1-bit per pixel and stored in a dual port static RAM (RAM, for Display Data RAM). The RAM size is 128x240 for UC1608. This array of data bits is further organized into pages of 8 bit slices to facilitate parallel bus interface.

When Mirror X (MX, LC[2]) is OFF, the 1st column of LCD pixels will correspond to the bits of the first byte of each page, the 2nd column of LCD pixels correspond to the bits of the second byte of each page, etc.

MSB FIRST OR LSB FIRST

There are two options to map D[7:0] to RAM, MSB first (MSF=1), or LSB first (MSF=0), as illustrated in next page.

DISPLAY DATA RAM ACCESS

The memory used in UC1608 Display Data RAM (RAM) is a special purpose dual port RAM which

allows asynchronous access to both its column and row data. Thus, RAM can be independently accessed both for Host Interface and for display operations.

DISPLAY DATA RAM ADDRESSING

A Host Interface (HI) memory access operation starts with specifying Page Address (PA) and Column Address (CA) by issuing *Set Page Address* and *Set Column Address* commands.

If wrap-around (WA, AC[0]) is OFF (0), CA will stop increasing after reaching the end of page (239), and system programmers need to set the values of PA and CA explicitly.

If WA is ON (1), when CA reaches end of page, CA will be reset to 0 and PA will increment or decrement, depending on the setting of Page Increment Direction (PID, AC[2]). When PA reaches the boundary of RAM (i.e. PA = 0 or 19), PA will be wrapped around to the other end of RAM and continue.

ULTRACHIP

High-Voltage Mixed-Signal IC

©1999-2002

MX IMPLEMENTATION

Column Mirroring (MX) is implemented by selecting either (CA) or (239-CA) as the RAM column address. Changing MX affects the data written to the RAM.

Since MX has no effect on data already stored in RAM, changing MX does not have immediate effect on the displayed pattern. To refresh the display, refresh the data stored in RAM after setting MX.

DISPLAY SCANNING

During each field of display, depending on the setting of MR, COM electrodes will be scanned in a fixed pattern at a rate of

$$(Frame\ Rate \times Mux\ Rate)\ \text{rows/second.}$$

During each row period, the signal at the SEG drivers determines the ON/OFF status of the row of pixels being scanned.

ROW SCANNING

For each field, the scanning starts at COM1 through COMx, where x depends on the setting of MR.

COM electrode scanning (row scanning) orders are not affected by Start Line (SL) or Mirror Y (MY, LC[3]). When MY is 0, the effect of SL having a value *K* is to change the mapping of COM1 to the *K*-th bit slice of data stored in display RAM. Visually, SL having a non-zero value is equivalent to scrolling LCD display up by SL rows.

RAM ADDRESS GENERATION

The mapping of the data stored in the display SRAM and the scanning electrodes can be obtained by combining the fixed Row scanning

sequence and the following RAM address generation formula.

During the display operation, the RAM line address generation can be mathematically represented as following:

$$\text{For the 1}^{\text{st}} \text{ line period of each field} \\ \text{Line} = \text{SL}$$

$$\text{Otherwise} \\ \text{Line} = \text{Mod}(\text{Line}+1, 128)$$

Where Mod is the modular operator, and *Line* is the bit slice line address of RAM to be outputted to SEG drivers. Line 0 corresponds to the first bit-slice of data in RAM.

The above *Line* generation formula produces the "loop around" effect as it effectively resets *Line* to 0 when *Line*+1 reaches 128.

Effects such as page scrolling can be emulated by changing SL dynamically.

MY IMPLEMENTATION

Row Mirroring (MY) is implemented by reversing the mapping order between COM electrodes and RAM, i.e. the mathematical address generation formula becomes:

$$\text{For the 1}^{\text{st}} \text{ line period of each field} \\ \text{Line} = \text{Mod}(\text{SL} + \text{MUX}-1, 128) \\ \text{where MUX} = 96 \text{ or } 128.$$

$$\text{Otherwise} \\ \text{Line} = \text{Mod}(\text{Line}-1, 128)$$

Visually, the effect of MY is equivalent to flipping the display upside down. The data stored in display RAM is not affected by MY.

RESET & POWER MANAGEMENT

TYPES OF RESET

UC1608 has two different types of Reset: *Power-ON-Reset* and *System-Reset*.

Power-ON-Reset is performed right after V_{DD} is connected to power. *Power-On-Reset* will first wait for about ~15mS, depending on the time required for V_{DD} to stabilize, and then trigger the *System Reset*.

System Reset can also be activated by software command or by connecting RST pin to ground. In the following discussions, Reset means *System Reset*.

RESET STATUS

When UC1608 enters RESET sequence:

- Operation mode will be "Reset"
- System Status bits RS and BZ will stay as "1" until the Reset process is completed. When RS=1, the IC will only respond to *Read Status* command. All other commands are ignored.
- All control registers are reset to default values. Refer to Control Registers for details of their default values.

OPERATION MODES

UC1608 has three operating modes (OM): Reset, Normal, Sleep.

Mode	Reset	Sleep	Normal
OM	00	10	11
Host Interface	Active	Active	Active
Clock	OFF	OFF	ON
LCD Drivers	OFF	OFF	ON
Charge Pump	OFF	OFF	ON
Draining Circuit	ON	OFF	OFF

Table 11: Operating Modes

CHANGING OPERATION MODE

In addition to Power-ON-Reset, two commands will initiate OM transitions:

Set Display Enable, and *System Reset*.

When DC[2] is modified by *Set Display Enable*, OM will be updated automatically. There is no other action required to enter Sleep mode.

For maximum energy utilization, Sleep mode is designed to retain charges stored in external capacitors C_{B0} , C_{B1} , and C_L . To drain these capacitors, use Reset command to activate the on-chip draining circuit.

Action	Mode	OM
Set Driver Enable to "0"	Sleep	10
Set Driver Enable to "1"	Normal	11
Reset command or RST_pin pulled "L" Power ON reset	Reset	00

Table 12: OM changes

Even though UC1608 consumes very little energy in Sleep mode (typically 5uA or less), however, since all capacitors are still charged, the leakage through COM drivers may damage the LCD over the long term. It is therefore recommended to use Sleep mode only for brief Display OFF operations, such as full-frame screen updates, and to use RESET for extended screen OFF operations.

EXITING SLEEP MODE

UC1608 contains internal logic to check whether V_{LCD} and V_{BIAS} are ready before releasing COM and SEG drivers from their idle states. When exiting Sleep or Reset Mode, COM and SEG drivers will not be activated until UC1608 internal voltage sources are restored to their proper values.

POWER-UP SEQUENCE

UC1608 power-up sequence is simplified by built-in "Power Ready" flags and the automatic invocation of *System-Reset* command after *Power-ON-Reset*.

System programmers are only required to wait 15~20 ms before the CPU starting to issue commands to UC1608. No additional time sequences are required between enabling the charge pump, turning on the display drivers, writing to RAM or any other commands.

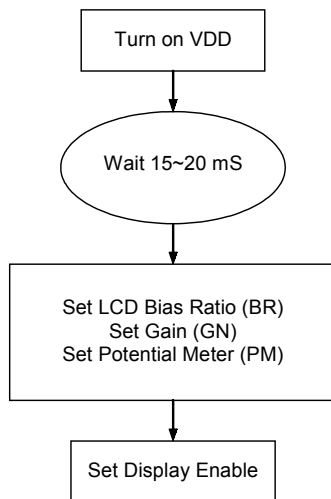
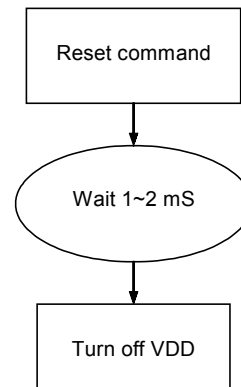

Figure 12: Reference Power-Up Sequence

POWER-DOWN SEQUENCE

To prevent the charge stored in capacitors C_{BX+} , C_{BX-} , and C_L from damaging the LCD when V_{DD} is switched off, use Reset mode to enable the built-in draining circuit and discharge these capacitors.

The draining resistor is 1K Ohm for both V_{LCD} and V_{B+} . It is recommended to wait $3 \times RC$ for V_{LCD} and $1.5 \times RC$ for V_{B+} . For example, if C_L is 10nF, then the draining time required for V_{LCD} is 1~2mS.

When internal V_{LCD} is not used, UC1608 will *NOT* drain V_{LCD} during RESET. System designers need to make sure external V_{LCD} source is properly drained off before turning off V_{DD} .

Figure 13: Reference Power-Down Sequence

SAMPLE POWER COMMAND SEQUENCES

The following tables are examples of command sequence for power-up, power-down and display ON/OFF operations. These are only to demonstrate some "typical, generic" scenarios. Designers are encouraged to study related sections of the datasheet and find out what the best parameters and control sequences are for their specific design needs.

C/D The type of the interface cycle. It can be either Command (0) or Data (1)

W/R The direction of data flow of the cycle. It can be either Write (0) or Read (1).

Type Required: These items are required

Customer: These item are not necessary if customer parameters are the same as default

Advanced: We recommend new users to skip these commands and use default values.

Optional: These commands depend on what users want to do.

POWER-UP

Type	C/D	W/R	D7	D6	D5	D4	D3	D2	D1	D0	Chip action	Comments
R	-	-	-	-	-	-	-	-	-	-	Automatic Power-ON-Reset.	Wait ~20ms after V _{DD} is ON
C	0	0	0	0	1	0	0	#	#	#	(5) Set MR and TC	
C	0	0	1	1	0	0	#	#	#	#	(15) Set LCD Mapping	Set up LCD specific parameters such as format, MX, MY, MSF, etc.
C	0	0	1	1	1	0	1	0	#	#	(18) Set Bias Ratio	
R	0	0	1	0	0	0	0	0	0	1	(9) Set Gain & PM	
C	1	0	#	#	#	#	#	#	#	#	Write display RAM	Set up display image
		
		
	1	0	#	#	#	#	#	#	#	#		
R	0	0	1	0	1	0	1	1	1	1	(13) Set Display Enable	

POWER-DOWN

Type	C/D	W/R	D7	D6	D5	D4	D3	D2	D1	D0	Chip action	Comments
R	0	0	1	1	1	0	0	0	1	0	(16) System Reset	
R	-	-	-	-	-	-	-	-	-	-	Draining capacitor	Wait 1~2ms before V _{DD} OFF

ULTRACHIP

High-Voltage Mixed-Signal IC

©1999~2002

BRIEF DISPLAY-OFF

Type	C/D	W/R	D7	D6	D5	D4	D3	D2	D1	D0	Chip action	Comments
R	0	0	1	0	1	0	1	1	1	0	(13) Set Display Disable	
C	1	0	#	#	#	#	#	#	#	#	Write display RAM	Set up display image (Image update is optional. Data in the RAM is retained through the SLEEP state.)
		
	1	0	#	#	#	#	#	#	#	#		
R	0	0	1	0	1	0	1	1	1	1	(13) Set Display Enable	

* This is only recommended for very brief display OFF (under 10mS).

If image becomes unstable use the *Extended Display OFF* approach shown below.

EXTENDED DISPLAY-OFF

Type	C/D	W/R	D7	D6	D5	D4	D3	D2	D1	D0	Chip action	Comments
R	0	0	1	1	1	0	0	0	1	0	(16) System Reset.	C _{B1} , C _{B1} , C _{LCD} discharged.
-	-	-	-	-	-	-	-	-	-	-		Extended display OFF Z z z z . . .
-	-	-	-	-	-	-	-	-	-	-		System waking up
C	1	0	#	#	#	#	#	#	#	#	Write display RAM	Set up display image (Image update is optional. Data in the RAM is retained through the RESET state.)
		
	1	0	#	#	#	#	#	#	#	#		
C	0	0	0	0	1	0	0	#	#	#	(5) Set MR and TC	
C	0	0	1	1	0	0	#	#	#	#	(15) Set LCD Mapping	Set up LCD specific parameters such as format, MX, MY, MSF, etc.
C	0	0	1	1	1	0	1	0	#	#	(18) Set Bias Ratio	
C	0	0	1	0	0	0	0	0	0	1	(9) Set Gain & PM	
	0	0	#	#	#	#	#	#	#	#		
R	0	0	1	0	1	0	1	1	1	1	(13) Set Display Disable	

* The sequence is basically the same as the power up sequence, except *Power-ON RESET* is replaced by *System RESET* command, and an extended idle time in between.

ABSOLUTE MAXIMUM RATINGS

In accordance with IEC134, note 1,2 and 3.

Symbol	Parameter	Min.	Max.	Unit
V _{DD}	Logic Supply voltage	-0.3	+4.0	V
V _{DD2}	LCD Generator Supply voltage	-0.3	+4.0	V
V _{DD3}	Analog Circuit Supply voltage	-0.3	+4.0	V
V _{LCD}	LCD Generated voltage (-30°C ~ +80°C)	-0.3	+17.0	V
V _{IN}	Any input voltage	-0.4	V _{DD} + 0.5	V
T _{OPR}	Operating temperature range	-30	+85	°C
T _{STR}	Storage temperature	-55	+125	°C

Notes

1. V_{DD} based on V_{SS} = 0V
2. Stress values listed above may cause permanent damages to the device.

ULTRACHIP

High-Voltage Mixed-Signal IC

©1999~2002

SPECIFICATIONS**DC CHARACTERISTICS**

Symbol	Parameter	Conditions	Min.	Typ.	Max.	Unit
V_{DD}	Supply for digital circuit		2.4	2.8	3.6	V
$V_{DD2/3}$	Supply for bias & pump		2.4	2.8	3.6	V
V_{LCD}	Charge pump output	$V_{DD2/3} \geq 2.4V, 25^{\circ}C$		12.5	15	V
V_D	LCD data voltage	$V_{DD2/3} \geq 2.4V, 25^{\circ}C$			1.2	V
V_{IL}	Input logic LOW				$0.2V_{DD}$	V
V_{IH}	Input logic HIGH		$0.8V_{DD}$			V
V_{OL}	Output logic LOW				$0.2V_{DD}$	V
V_{OH}	Output logic HIGH		$0.8V_{DD}$			V
I_{IL}	Input leakage current				1.5	μA
C_{IN}	Input capacitance			5	10	PF
C_{OUT}	Output capacitance			5	10	PF
$R_{0(SEG)}$	SEG output impedance	$V_{LCD} = 12.5V$		1.5	3	$k\Omega$
$R_{0(COM)}$	COM output impedance	$V_{LCD} = 12.5V$		1.5	3	$k\Omega$
f_{LINE}	Average frame rate			90		Hz

AC CHARACTERISTICS

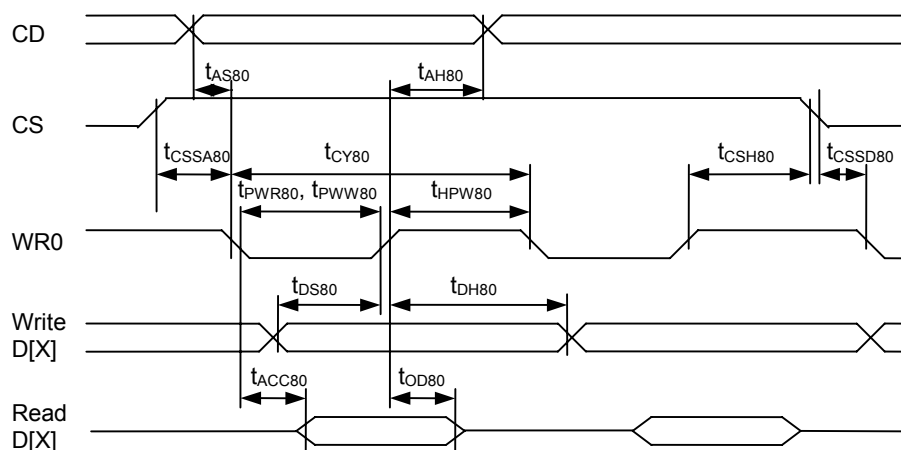

Figure 21: Parallel Bus Timing Characteristics (for 8080 MCU)

(VDD=2.4V to 3.3V, Ta= -30 to +85°C)

Symbol	Signal	Description	Condition	Min.	Max.	Units
t _{AS80} t _{AH80}	CD	Address setup time Address hold time		0 10	–	ns
t _{CY80}		System cycle time 8 bits bus (read) (write) 4 bits bus (read) (write)		140 140 80 80	–	ns
t _{PWR80}	WR1	Pulse width 8 bits (read) 4 bits		65 35	–	ns
t _{PWW80}	WR0	Pulse width 8 bits (write) 4 bits		65 35	–	ns
t _{HPW80}	WR0, WR1	High pulse width 8 bits bus (read) (write) 4 bits bus (read) (write)		65 65 35 35	–	ns
t _{DS80} t _{DH80}	D0~D7	Data setup time Data hold time		30 10	–	ns
t _{ACC80} t _{OD80}		Read access time Output disable time	C _L = 100pF	– 10	50 50	ns
t _{CSSA80} t _{CSSD80} t _{CSH80}	CS	Chip select setup time		10 10 20		ns

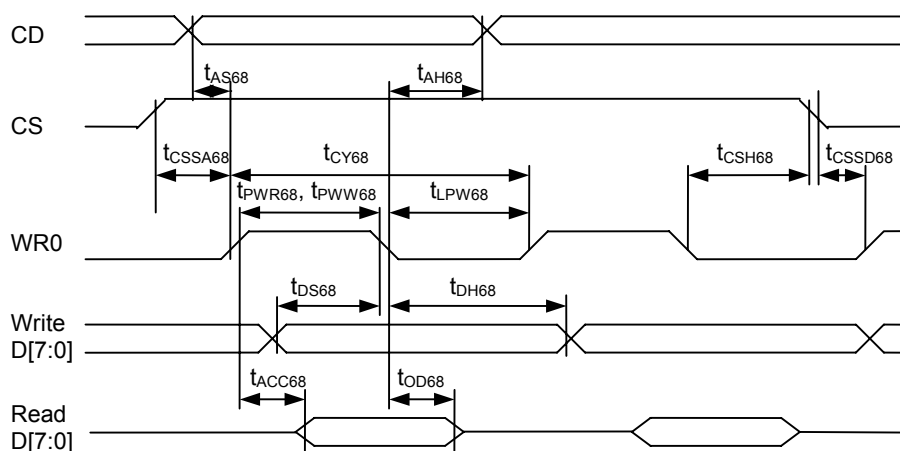

Figure 22: Parallel Bus Timing Characteristics (for 6800 MCU)

(VDD=2.4V to 3.3V, Ta= -30 to +85°C)

Symbol	Signal	Description	Condition	Min.	Max.	Units
t_{AS68} t_{AH68}	CD	Address setup time Address hold time		0 10	-	ns
t_{CY68}		System cycle time 8 bits bus (read) (write) 4 bits bus (read) (write)		140 140 80 80	-	ns
t_{PWR68}	WR1	Pulse width 8 bits (read) 4 bits		65 35	-	ns
t_{PWW68}		Pulse width 8 bits (write) 4 bits		65 35	-	ns
t_{LPW68}		Low pulse width 8 bits bus (read) (write) 4 bits bus (read) (write)		65 65 35 35	-	ns
t_{DS68} t_{DH68}	D0~D7	Data setup time Data hold time		30 10	-	ns
t_{ACC68} t_{OD68}		Read access time Output disable time	$C_L = 100\text{pF}$	- 10	50 50	ns
T_{CSSA68} T_{CSSD68} T_{CSH68}	CS	Chip select setup time		10 10 20		ns

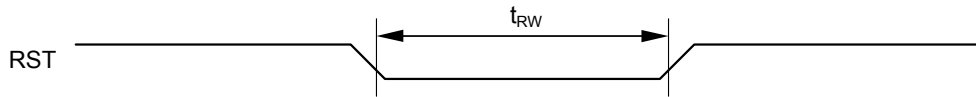

Figure 25: Reset Characteristics

(VDD=2.4V to 3.3V, Ta= -30 to +85°C)

Symbol	Signal	Description	Condition	Min.	Max.	Units
t_{RW}	RST	Reset low pulse width		1000	–	ns

ULTRACHIP

High-Voltage Mixed-Signal IC

©1999~2002

PHYSICAL DIMENSIONS**CHIP SIZE**

12.603x 1.248mm

DIE THICKNESS:

0.5mm

AU BUMP HEIGHT:17 $\mu\text{m} \pm 1 \mu\text{m}$ (within die)**AU BUMP PITCH:**50 μm **AU BUMP SIZE:**94 x 32 μm 94 x 51 μm 106 x 48 μm **DUMMY BUMP SIZE:**94 x 57 μm 106 x 48 μm **PAD COORDINATES:**

Pad center

PAD ORIGIN:

Chip center

(Drawing and coordinates are for the Circuit/Bump view.)

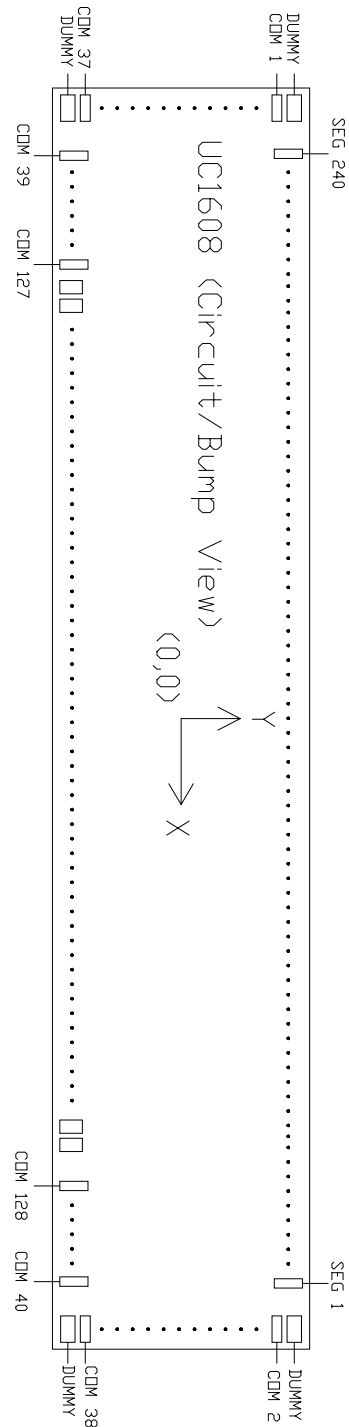

DataSheet4U

DataSheet4U

COF INFORMATION

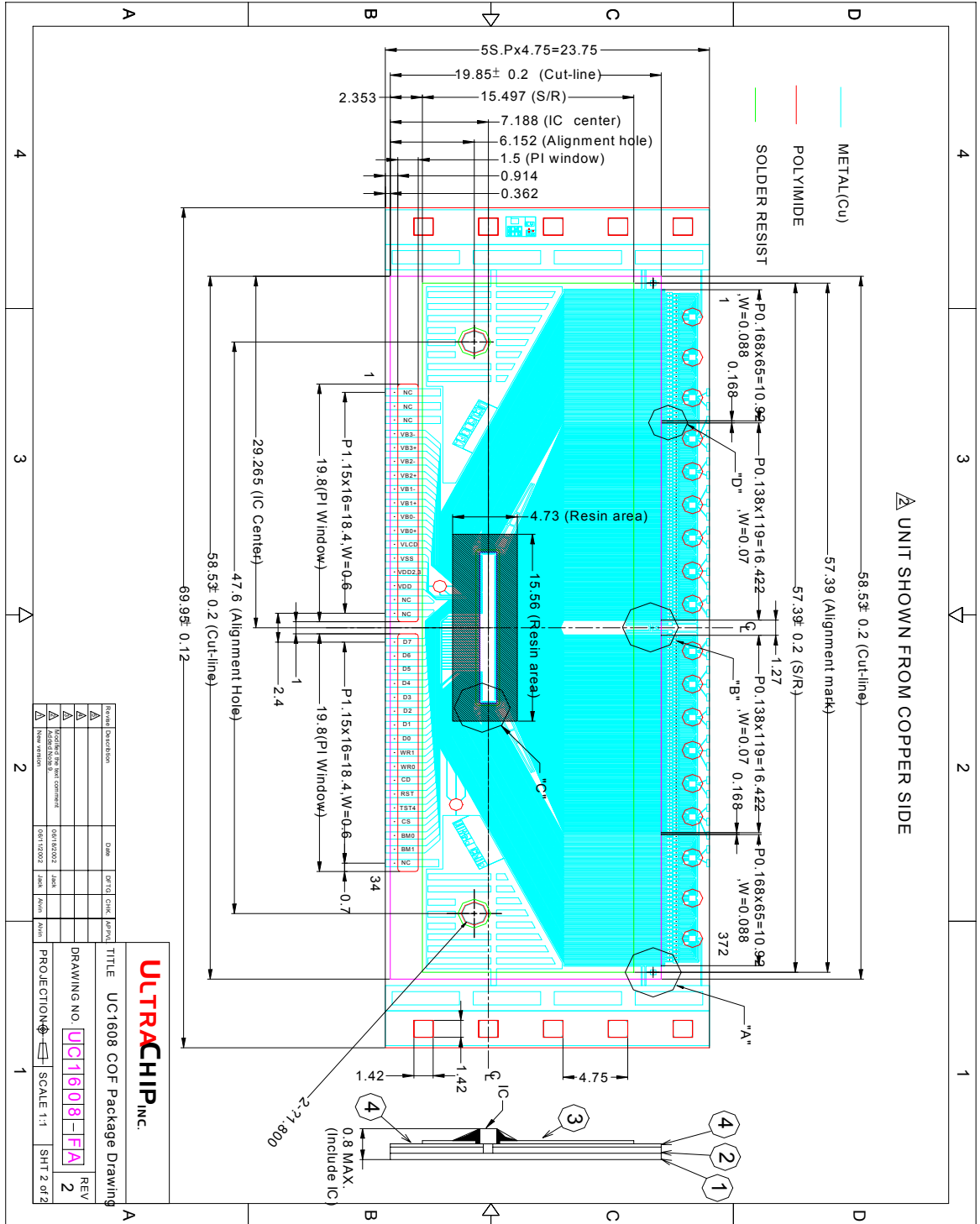

COF INFORMATION

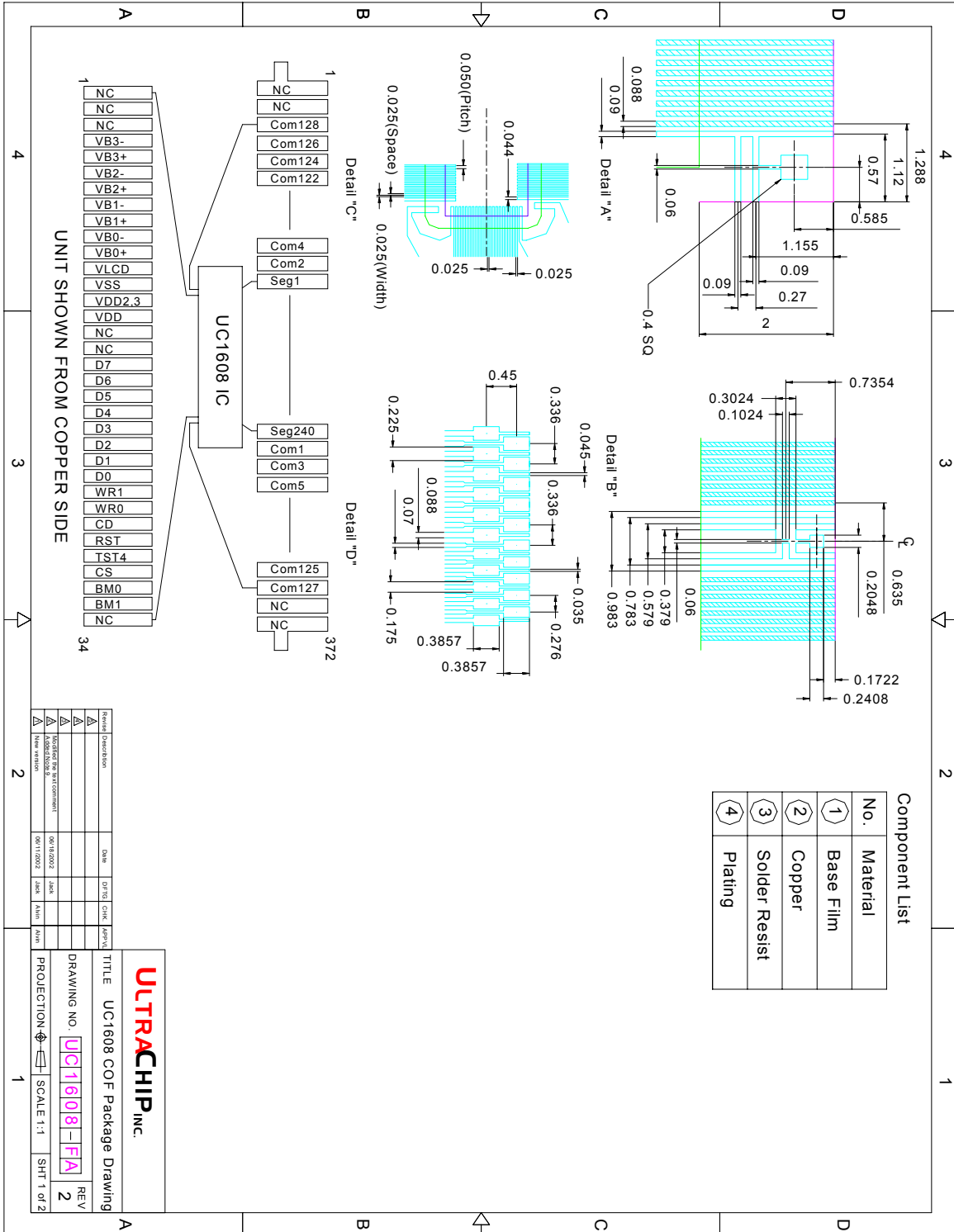

PAD COORDINATES

Pin	Name	X	Y	W	H
1	Dummy	-6185.5	-509.5	94	57
2	COM37	-6185.5	-450.0	94	32
3	COM35	-6185.5	-400.0	94	32
4	COM33	-6185.5	-350.0	94	32
5	COM31	-6185.5	-300.0	94	32
6	COM29	-6185.5	-250.0	94	32
7	COM27	-6185.5	-200.0	94	32
8	COM25	-6185.5	-150.0	94	32
9	COM23	-6185.5	-100.0	94	32
10	COM21	-6185.5	-50.0	94	32
11	COM19	-6185.5	0.0	94	32
12	COM17	-6185.5	50.0	94	32
13	COM15	-6185.5	100.0	94	32
14	COM13	-6185.5	150.0	94	32
15	COM11	-6185.5	200.0	94	32
16	COM9	-6185.5	250.0	94	32
17	COM7	-6185.5	300.0	94	32
18	COM5	-6185.5	350.0	94	32
19	COM3	-6185.5	400.0	94	32
20	COM1	-6185.5	450.0	94	32
21	Dummy	-6185.5	509.5	94	57
22	COM39	-6006.1	-521.0	51	94
23	COM41	-5946.6	-521.0	32	94
24	COM43	-5896.6	-521.0	32	94
25	COM45	-5846.6	-521.0	32	94
26	COM47	-5796.6	-521.0	32	94
27	COM49	-5746.6	-521.0	32	94
28	COM51	-5696.6	-521.0	32	94
29	COM53	-5646.6	-521.0	32	94
30	COM55	-5596.6	-521.0	32	94
31	COM57	-5546.6	-521.0	32	94
32	COM59	-5496.6	-521.0	32	94
33	COM61	-5446.6	-521.0	32	94
34	COM63	-5396.6	-521.0	32	94
35	COM65	-5346.6	-521.0	32	94
36	COM67	-5296.6	-521.0	32	94
37	COM69	-5246.6	-521.0	32	94
38	COM71	-5196.6	-521.0	32	94
39	COM73	-5146.6	-521.0	32	94
40	COM75	-5096.6	-521.0	32	94
41	COM77	-5046.6	-521.0	32	94
42	COM79	-4996.6	-521.0	32	94
43	COM81	-4946.6	-521.0	32	94
44	COM83	-4896.6	-521.0	32	94
45	COM85	-4846.6	-521.0	32	94
46	COM87	-4796.6	-521.0	32	94

Pin	Name	X	Y	W	H
47	COM89	-4746.6	-521.0	32	94
48	COM91	-4696.6	-521.0	32	94
49	COM93	-4646.6	-521.0	32	94
50	COM95	-4596.6	-521.0	32	94
51	COM97	-4546.6	-521.0	32	94
52	COM99	-4496.6	-521.0	32	94
53	COM101	-4446.6	-521.0	32	94
54	COM103	-4396.6	-521.0	32	94
55	COM105	-4346.6	-521.0	32	94
56	COM107	-4296.6	-521.0	32	94
57	COM109	-4246.6	-521.0	32	94
58	COM111	-4196.6	-521.0	32	94
59	COM113	-4146.6	-521.0	32	94
60	COM115	-4096.6	-521.0	32	94
61	COM117	-4046.6	-521.0	32	94
62	COM119	-3996.6	-521.0	32	94
63	COM121	-3946.6	-521.0	32	94
64	COM123	-3896.6	-521.0	32	94
65	COM125	-3846.6	-521.0	32	94
66	COM127	-3796.6	-521.0	32	94
67	TST2	-3746.6	-521.0	32	94
68	TST3	-3687.1	-521.0	51	94
69	Dummy	-3351.9	-544.0	106	48
70	Dummy	-3226.9	-544.0	106	48
71	Dummy	-3102.0	-544.0	106	48
72	Dummy	-2977.0	-544.0	106	48
73	Dummy	-2852.0	-544.0	106	48
74	Dummy	-2727.0	-544.0	106	48
75	Dummy	-2602.1	-544.0	106	48
76	Dummy	-2477.1	-544.0	106	48
77	Dummy	-2352.1	-544.0	106	48
78	Dummy	-2227.1	-544.0	106	48
79	Dummy	-2102.2	-544.0	106	48
80	Dummy	-1977.2	-544.0	106	48
81	Dummy	-1852.2	-544.0	106	48
82	Dummy	-1727.2	-544.0	106	48
83	Dummy	-1602.3	-544.0	106	48
84	Dummy	-1477.3	-544.0	106	48
85	Dummy	-1352.3	-544.0	106	48
86	Dummy	-1227.3	-544.0	106	48
87	Dummy	-1102.4	-544.0	106	48
88	Dummy	-977.4	-544.0	106	48
89	Dummy	-852.4	-544.0	106	48
90	Dummy	-727.4	-544.0	106	48
91	Dummy	-602.5	-544.0	106	48
92	Dummy	-477.5	-544.0	106	48

ULTRACHIP

High-Voltage Mixed-Signal IC

©1999~2002

Pin	Name	X	Y	W	H
93	Dummy	-352.5	-544.0	106	48
94	Dummy	-227.5	-544.0	106	48
95	Dummy	-102.6	-544.0	106	48
96	Dummy	22.4	-544.0	106	48
97	Dummy	147.4	-544.0	106	48
98	Dummy	272.4	-544.0	106	48
99	Dummy	397.4	-544.0	106	48
100	BM1	1198.7	-515.0	48	106
101	BM0	1268.7	-515.0	48	106
102	CS	1338.7	-515.0	48	106
103	TST4	1408.7	-515.0	48	106
104	RST	1478.7	-515.0	48	106
105	CD	1548.7	-515.0	48	106
106	WR0	1618.7	-515.0	48	106
107	WR1	1688.7	-515.0	48	106
108	D0	1758.7	-515.0	48	106
109	D1	1828.7	-515.0	48	106
110	D2	1898.7	-515.0	48	106
111	D3	1968.7	-515.0	48	106
112	D4	2038.7	-515.0	48	106
113	D5	2108.7	-515.0	48	106
114	D6	2178.7	-515.0	48	106
115	D7	2248.7	-515.0	48	106
116	VDD	2342.0	-515.0	48	106
117	VDD2	2412.0	-515.0	48	106
118	VDD3	2482.0	-515.0	48	106
119	VSS2	2552.0	-515.0	48	106
120	VSS	2622.0	-515.0	48	106
121	TP1	2696.7	-521.0	32	94
122	TP2	2746.7	-521.0	32	94
123	TP3	2796.7	-521.0	32	94
124	VLCDOUT	2846.7	-521.0	32	94
125	VLCDIN	2896.7	-521.0	32	94
126	TST1	2946.7	-521.0	32	94
127	VB0+	2996.7	-521.0	32	94
128	SB0+	3046.7	-521.0	32	94
129	VB0-	3096.7	-521.0	32	94
130	SB0-	3146.7	-521.0	32	94
131	VB1+	3196.7	-521.0	32	94
132	SB1+	3246.7	-521.0	32	94
133	VB1-	3296.7	-521.0	32	94
134	SB1-	3346.7	-521.0	32	94
135	VB2+	3396.7	-521.0	32	94
136	SB2+	3446.7	-521.0	32	94
137	VB2-	3496.7	-521.0	32	94
138	SB2-	3546.7	-521.0	32	94
139	VB3+	3596.7	-521.0	32	94
140	SB3+	3646.7	-521.0	32	94

Pin	Name	X	Y	W	H
141	VB3-	3696.7	-521.0	32	94
142	SB3-	3746.7	-521.0	32	94
143	COM128	3796.7	-521.0	32	94
144	COM126	3846.7	-521.0	32	94
145	COM124	3896.7	-521.0	32	94
146	COM122	3946.7	-521.0	32	94
147	COM120	3996.7	-521.0	32	94
148	COM118	4046.7	-521.0	32	94
149	COM116	4096.7	-521.0	32	94
150	COM114	4146.7	-521.0	32	94
151	COM112	4196.7	-521.0	32	94
152	COM110	4246.7	-521.0	32	94
153	COM108	4296.7	-521.0	32	94
154	COM106	4346.7	-521.0	32	94
155	COM104	4396.7	-521.0	32	94
156	COM102	4446.7	-521.0	32	94
157	COM100	4496.7	-521.0	32	94
158	COM98	4546.7	-521.0	32	94
159	COM96	4596.7	-521.0	32	94
160	COM94	4646.7	-521.0	32	94
161	COM92	4696.7	-521.0	32	94
162	COM90	4746.7	-521.0	32	94
163	COM88	4796.7	-521.0	32	94
164	COM86	4846.7	-521.0	32	94
165	COM84	4896.7	-521.0	32	94
166	COM82	4946.7	-521.0	32	94
167	COM80	4996.7	-521.0	32	94
168	COM78	5046.7	-521.0	32	94
169	COM76	5096.7	-521.0	32	94
170	COM74	5146.7	-521.0	32	94
171	COM72	5196.7	-521.0	32	94
172	COM70	5246.7	-521.0	32	94
173	COM68	5296.7	-521.0	32	94
174	COM66	5346.7	-521.0	32	94
175	COM64	5396.7	-521.0	32	94
176	COM62	5446.7	-521.0	32	94
177	COM60	5496.7	-521.0	32	94
178	COM58	5546.7	-521.0	32	94
179	COM56	5596.7	-521.0	32	94
180	COM54	5646.7	-521.0	32	94
181	COM52	5696.7	-521.0	32	94
182	COM50	5746.7	-521.0	32	94
183	COM48	5796.7	-521.0	32	94
184	COM46	5846.7	-521.0	32	94
185	COM44	5896.7	-521.0	32	94
186	COM42	5946.7	-521.0	32	94
187	COM40	6006.2	-521.0	51	94
188	Dummy	6185.5	-509.5	94	57

UC1608

128x240 Matrix LCD Controller-Drivers

Pin	Name	X	Y	W	H	Pin	Name	X	Y	W	H
189	COM38	6185.5	-450.0	94	32	237	SEG29	4575.0	521.0	32	94
190	COM36	6185.5	-400.0	94	32	238	SEG30	4525.0	521.0	32	94
191	COM34	6185.5	-350.0	94	32	239	SEG31	4475.0	521.0	32	94
192	COM32	6185.5	-300.0	94	32	240	SEG32	4425.0	521.0	32	94
193	COM30	6185.5	-250.0	94	32	241	SEG33	4375.0	521.0	32	94
194	COM28	6185.5	-200.0	94	32	242	SEG34	4325.0	521.0	32	94
195	COM26	6185.5	-150.0	94	32	243	SEG35	4275.0	521.0	32	94
196	COM24	6185.5	-100.0	94	32	244	SEG36	4225.0	521.0	32	94
197	COM22	6185.5	-50.0	94	32	245	SEG37	4175.0	521.0	32	94
198	COM20	6185.5	0.0	94	32	246	SEG38	4125.0	521.0	32	94
199	COM18	6185.5	50.0	94	32	247	SEG39	4075.0	521.0	32	94
200	COM16	6185.5	100.0	94	32	248	SEG40	4025.0	521.0	32	94
201	COM14	6185.5	150.0	94	32	249	SEG41	3975.0	521.0	32	94
202	COM12	6185.5	200.0	94	32	250	SEG42	3925.0	521.0	32	94
203	COM10	6185.5	250.0	94	32	251	SEG43	3875.0	521.0	32	94
204	COM8	6185.5	300.0	94	32	252	SEG44	3825.0	521.0	32	94
205	COM6	6185.5	350.0	94	32	253	SEG45	3775.0	521.0	32	94
206	COM4	6185.5	400.0	94	32	254	SEG46	3725.0	521.0	32	94
207	COM2	6185.5	450.0	94	32	255	SEG47	3675.0	521.0	32	94
208	Dummy	6185.5	509.5	94	57	256	SEG48	3625.0	521.0	32	94
209	SEG1	5984.5	521.0	51	94	257	SEG49	3575.0	521.0	32	94
210	SEG2	5925.0	521.0	32	94	258	SEG50	3525.0	521.0	32	94
211	SEG3	5875.0	521.0	32	94	259	SEG51	3475.0	521.0	32	94
212	SEG4	5825.0	521.0	32	94	260	SEG52	3425.0	521.0	32	94
213	SEG5	5775.0	521.0	32	94	261	SEG53	3375.0	521.0	32	94
214	SEG6	5725.0	521.0	32	94	262	SEG54	3325.0	521.0	32	94
215	SEG7	5675.0	521.0	32	94	263	SEG55	3275.0	521.0	32	94
216	SEG8	5625.0	521.0	32	94	264	SEG56	3225.0	521.0	32	94
217	SEG9	5575.0	521.0	32	94	265	SEG57	3175.0	521.0	32	94
218	SEG10	5525.0	521.0	32	94	266	SEG58	3125.0	521.0	32	94
219	SEG11	5475.0	521.0	32	94	267	SEG59	3075.0	521.0	32	94
220	SEG12	5425.0	521.0	32	94	268	SEG60	3025.0	521.0	32	94
221	SEG13	5375.0	521.0	32	94	269	SEG61	2975.0	521.0	32	94
222	SEG14	5325.0	521.0	32	94	270	SEG62	2925.0	521.0	32	94
223	SEG15	5275.0	521.0	32	94	271	SEG63	2875.0	521.0	32	94
224	SEG16	5225.0	521.0	32	94	272	SEG64	2825.0	521.0	32	94
225	SEG17	5175.0	521.0	32	94	273	SEG65	2775.0	521.0	32	94
226	SEG18	5125.0	521.0	32	94	274	SEG66	2725.0	521.0	32	94
227	SEG19	5075.0	521.0	32	94	275	SEG67	2675.0	521.0	32	94
228	SEG20	5025.0	521.0	32	94	276	SEG68	2625.0	521.0	32	94
229	SEG21	4975.0	521.0	32	94	277	SEG69	2575.0	521.0	32	94
230	SEG22	4925.0	521.0	32	94	278	SEG70	2525.0	521.0	32	94
231	SEG23	4875.0	521.0	32	94	279	SEG71	2475.0	521.0	32	94
232	SEG24	4825.0	521.0	32	94	280	SEG72	2425.0	521.0	32	94
233	SEG25	4775.0	521.0	32	94	281	SEG73	2375.0	521.0	32	94
234	SEG26	4725.0	521.0	32	94	282	SEG74	2325.0	521.0	32	94
235	SEG27	4675.0	521.0	32	94	283	SEG75	2275.0	521.0	32	94
236	SEG28	4625.0	521.0	32	94	284	SEG76	2225.0	521.0	32	94

ULTRACHIP

High-Voltage Mixed-Signal IC

©1999~2002

Pin	Name	X	Y	W	H
285	SEG77	2175.0	521.0	32	94
286	SEG78	2125.0	521.0	32	94
287	SEG79	2075.0	521.0	32	94
288	SEG80	2025.0	521.0	32	94
289	SEG81	1975.0	521.0	32	94
290	SEG82	1925.0	521.0	32	94
291	SEG83	1875.0	521.0	32	94
292	SEG84	1825.0	521.0	32	94
293	SEG85	1775.0	521.0	32	94
294	SEG86	1725.0	521.0	32	94
295	SEG87	1675.0	521.0	32	94
296	SEG88	1625.0	521.0	32	94
297	SEG89	1575.0	521.0	32	94
298	SEG90	1525.0	521.0	32	94
299	SEG91	1475.0	521.0	32	94
300	SEG92	1425.0	521.0	32	94
301	SEG93	1375.0	521.0	32	94
302	SEG94	1325.0	521.0	32	94
303	SEG95	1275.0	521.0	32	94
304	SEG96	1225.0	521.0	32	94
305	SEG97	1175.0	521.0	32	94
306	SEG98	1125.0	521.0	32	94
307	SEG99	1075.0	521.0	32	94
308	SEG100	1025.0	521.0	32	94
309	SEG101	975.0	521.0	32	94
310	SEG102	925.0	521.0	32	94
311	SEG103	875.0	521.0	32	94
312	SEG104	825.0	521.0	32	94
313	SEG105	775.0	521.0	32	94
314	SEG106	725.0	521.0	32	94
315	SEG107	675.0	521.0	32	94
316	SEG108	625.0	521.0	32	94
317	SEG109	575.0	521.0	32	94
318	SEG110	525.0	521.0	32	94
319	SEG111	475.0	521.0	32	94
320	SEG112	425.0	521.0	32	94
321	SEG113	375.0	521.0	32	94
322	SEG114	325.0	521.0	32	94
323	SEG115	275.0	521.0	32	94
324	SEG116	225.0	521.0	32	94
325	SEG117	175.0	521.0	32	94
326	SEG118	125.0	521.0	32	94
327	SEG119	75.0	521.0	32	94
328	SEG120	25.0	521.0	32	94
329	SEG121	-25.0	521.0	32	94
330	SEG122	-75.0	521.0	32	94
331	SEG123	-125.0	521.0	32	94
332	SEG124	-175.0	521.0	32	94

Pin	Name	X	Y	W	H
333	SEG125	-225.0	521.0	32	94
334	SEG126	-275.0	521.0	32	94
335	SEG127	-325.0	521.0	32	94
336	SEG128	-375.0	521.0	32	94
337	SEG129	-425.0	521.0	32	94
338	SEG130	-475.0	521.0	32	94
339	SEG131	-525.0	521.0	32	94
340	SEG132	-575.0	521.0	32	94
341	SEG133	-625.0	521.0	32	94
342	SEG134	-675.0	521.0	32	94
343	SEG135	-725.0	521.0	32	94
344	SEG136	-775.0	521.0	32	94
345	SEG137	-825.0	521.0	32	94
346	SEG138	-875.0	521.0	32	94
347	SEG139	-925.0	521.0	32	94
348	SEG140	-975.0	521.0	32	94
349	SEG141	-1025.0	521.0	32	94
350	SEG142	-1075.0	521.0	32	94
351	SEG143	-1125.0	521.0	32	94
352	SEG144	-1175.0	521.0	32	94
353	SEG145	-1225.0	521.0	32	94
354	SEG146	-1275.0	521.0	32	94
355	SEG147	-1325.0	521.0	32	94
356	SEG148	-1375.0	521.0	32	94
357	SEG149	-1425.0	521.0	32	94
358	SEG150	-1475.0	521.0	32	94
359	SEG151	-1525.0	521.0	32	94
360	SEG152	-1575.0	521.0	32	94
361	SEG153	-1625.0	521.0	32	94
362	SEG154	-1675.0	521.0	32	94
363	SEG155	-1725.0	521.0	32	94
364	SEG156	-1775.0	521.0	32	94
365	SEG157	-1825.0	521.0	32	94
366	SEG158	-1875.0	521.0	32	94
367	SEG159	-1925.0	521.0	32	94
368	SEG160	-1975.0	521.0	32	94
369	SEG161	-2025.0	521.0	32	94
370	SEG162	-2075.0	521.0	32	94
371	SEG163	-2125.0	521.0	32	94
372	SEG164	-2175.0	521.0	32	94
373	SEG165	-2225.0	521.0	32	94
374	SEG166	-2275.0	521.0	32	94
375	SEG167	-2325.0	521.0	32	94
376	SEG168	-2375.0	521.0	32	94
377	SEG169	-2425.0	521.0	32	94
378	SEG170	-2475.0	521.0	32	94
379	SEG171	-2525.0	521.0	32	94
380	SEG172	-2575.0	521.0	32	94

UC1608

128x240 Matrix LCD Controller-Drivers

Pin	Name	X	Y	W	H
381	SEG173	-2625.0	521.0	32	94
382	SEG174	-2675.0	521.0	32	94
383	SEG175	-2725.0	521.0	32	94
384	SEG176	-2775.0	521.0	32	94
385	SEG177	-2825.0	521.0	32	94
386	SEG178	-2875.0	521.0	32	94
387	SEG179	-2925.0	521.0	32	94
388	SEG180	-2975.0	521.0	32	94
389	SEG181	-3025.0	521.0	32	94
390	SEG182	-3075.0	521.0	32	94
391	SEG183	-3125.0	521.0	32	94
392	SEG184	-3175.0	521.0	32	94
393	SEG185	-3225.0	521.0	32	94
394	SEG186	-3275.0	521.0	32	94
395	SEG187	-3325.0	521.0	32	94
396	SEG188	-3375.0	521.0	32	94
397	SEG189	-3425.0	521.0	32	94
398	SEG190	-3475.0	521.0	32	94
399	SEG191	-3525.0	521.0	32	94
400	SEG192	-3575.0	521.0	32	94
401	SEG193	-3625.0	521.0	32	94
402	SEG194	-3675.0	521.0	32	94
403	SEG195	-3725.0	521.0	32	94
404	SEG196	-3775.0	521.0	32	94
405	SEG197	-3825.0	521.0	32	94
406	SEG198	-3875.0	521.0	32	94
407	SEG199	-3925.0	521.0	32	94
408	SEG200	-3975.0	521.0	32	94
409	SEG201	-4025.0	521.0	32	94
410	SEG202	-4075.0	521.0	32	94
411	SEG203	-4125.0	521.0	32	94
412	SEG204	-4175.0	521.0	32	94
413	SEG205	-4225.0	521.0	32	94
414	SEG206	-4275.0	521.0	32	94
415	SEG207	-4325.0	521.0	32	94
416	SEG208	-4375.0	521.0	32	94
417	SEG209	-4425.0	521.0	32	94
418	SEG210	-4475.0	521.0	32	94
419	SEG211	-4525.0	521.0	32	94
420	SEG212	-4575.0	521.0	32	94
421	SEG213	-4625.0	521.0	32	94
422	SEG214	-4675.0	521.0	32	94
423	SEG215	-4725.0	521.0	32	94
424	SEG216	-4775.0	521.0	32	94
425	SEG217	-4825.0	521.0	32	94
426	SEG218	-4875.0	521.0	32	94
427	SEG219	-4925.0	521.0	32	94
428	SEG220	-4975.0	521.0	32	94

Pin	Name	X	Y	W	H
429	SEG221	-5025.0	521.0	32	94
430	SEG222	-5075.0	521.0	32	94
431	SEG223	-5125.0	521.0	32	94
432	SEG224	-5175.0	521.0	32	94
433	SEG225	-5225.0	521.0	32	94
434	SEG226	-5275.0	521.0	32	94
435	SEG227	-5325.0	521.0	32	94
436	SEG228	-5375.0	521.0	32	94
437	SEG229	-5425.0	521.0	32	94
438	SEG230	-5475.0	521.0	32	94
439	SEG231	-5525.0	521.0	32	94
440	SEG232	-5575.0	521.0	32	94
441	SEG233	-5625.0	521.0	32	94
442	SEG234	-5675.0	521.0	32	94
443	SEG235	-5725.0	521.0	32	94
444	SEG236	-5775.0	521.0	32	94
445	SEG237	-5825.0	521.0	32	94
446	SEG238	-5875.0	521.0	32	94
447	SEG239	-5925.0	521.0	32	94
448	SEG240	-5984.5	521.0	51	94