



## UC3655

CMOS IC

### 500mA SYNCHRONOUS STEP-DOWN DC/DC CONVERTERS

#### DESCRIPTION

The UTC **UC3655** is a synchronous-rectification type DC/DC converters with a built-in 0.6Ω P-channel driver transistor and 0.7Ω N-channel switching transistor, which designed to allow the use of ceramic capacitors. Using only a coil and two capacitors connected externally, the **UC3655** enable a high efficiency, stable power supply with an output current of 500mA to be configured. Its operating voltage is 2.0V and the output voltage is programmable in a range from 0.9V to 4.0V in increments of 0.1V (accuracy: ±2.0%) internally. The oscillation frequency is 1.3MHz.

For operation mode, it is PWM control in the UTC **UC3655**, the UTC **UC3655** series is automatic PWM/PFM switching control, allowing fast response, low ripple and high efficiency over the full range of load.

Internal soft start and current control functions are built in it. All circuits are shutdown to reduce current consumption to as low as 1.0μA or less during standby mode. With the built-in Under Voltage Lock Out (U.V.L.O.) function, when input voltage becomes 1.4V or lower the internal P channel driver transistor is forced OFF.

#### FEATURES

- \* Very High Efficiency 92%
- \* Low Ripple Rejection Voltage 10mV
- \* Output Current 500mA @ $V_{IN}=3.0V$ ,  $V_{OUT}=1.8V$
- \* Oscillation Frequency is 1.3MHz
- \* With PWM / PFM Automatic Switching Control
- \* Maximum Duty Ratio is 100%
- \* Ceramic Capacitor Available

#### ORDERING INFORMATION

Ordering Number		Package	Packing
Lead Free	Halogen Free		
UC3655L-xx-AF5-R	UC3655G-xx-AF5-R	SOT-25	Tape Reel

<p>UC3655L-xx-AF5-R</p> <p>(1)Packing Type (2)Package Type (3)Output Voltage Code (4)Lead Free</p>	<p>(1) R: Tape Reel (2) AF5: SOT-25 (3) xx: refer to Marking Information (4) L: Lead Free, G: Halogen Free</p>
--	--

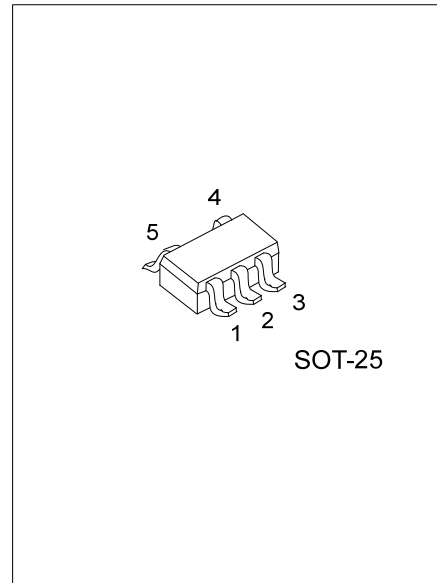

### MARKING

PACKAGE	VOLTAGE CODE	MARKING
SOT-25	12: 1.2V 28: 2.8V 33: 3.3V 38: 3.8V	

### PIN DESCRIPTION

PIN NO	PIN NAME	DESCRIPTION
1	$V_{IN}$	Power Input Voltage
2	$V_{SS}$	Ground
3	CE / MODE	Switch Pin For Chip Enable Mode
4	$V_{OUT}$	Output Voltage Sense Pin
5	$L_X$	Output Of Switching

### BLOCK DIAGRAM

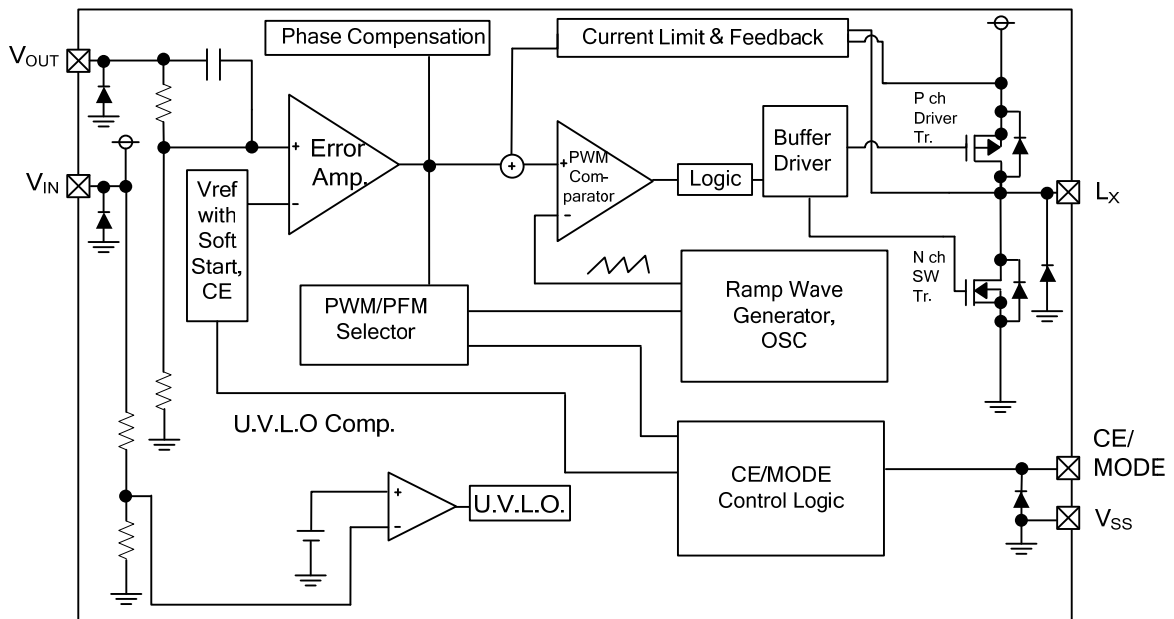

■ ABSOLUTE MAXIMUM RATING (T<sub>A</sub>=25°C, unless otherwise specified)

PARAMETER	SYMBOL	RATINGS	UNIT
V <sub>IN</sub> Pin Voltage	V <sub>IN</sub>	- 0.3 ~ 6.5	V
Input/Output Pins	LX	V <sub>LX</sub>	- 0.3 ~ V <sub>IN</sub> + 0.3
	V <sub>OUT</sub>	V <sub>OUT</sub>	-0.3 ~ 6.5
	CE/MODE	V <sub>CE</sub>	- 0.3 ~ V <sub>IN</sub> + 0.3
Lx Pin Current	I <sub>LX</sub>	±1000	mA
Power Dissipation	P <sub>D</sub>	250	mW
Operating Temperature	T <sub>OPR</sub>	- 40 ~ 85	°C
Storage Temperature Range	T <sub>STG</sub>	- 55 ~ 125	°C

Note: Absolute maximum ratings are those values beyond which the device could be permanently damaged. Absolute maximum ratings are stress ratings only and functional device operation is not implied.

■ ELECTRICAL CHARACTERISTICS (f<sub>OSC</sub>=1.2MHz, T<sub>A</sub>=25°C, unless otherwise specified)

UC3655-12 (V<sub>IN</sub>=3.6V, V<sub>OUT</sub>=1.2V)

PARAMETER	SYMBOL	TEST CONDITIONS	MIN	TYP	MAX	UNIT
Operating Voltage Range	V <sub>IN</sub>		2.0		6.0	V
Output Voltage	V <sub>OUT</sub>	CE=V <sub>IN</sub> , I <sub>OUT</sub> =30mA	1.176	1.200	1.224	V
U.V.L.O. Voltage	V <sub>UVLO</sub>	CE=V <sub>IN</sub> , V <sub>OUT</sub> =0V, LX=L	1.0	1.40	1.78	V
Output Voltage Temperature Characteristics	$\frac{\Delta V_{OUT}}{V_{OUT} \cdot \Delta T_{OPR}}$	I <sub>OUT</sub> =30mA, -40°C ≤ T <sub>OPR</sub> ≤ 85°C		±100		ppm/°C
Maximum Output Current	I <sub>OUT(MAX)</sub>	V <sub>IN</sub> =4.5V	500			mA
Supply Current	I <sub>DD</sub>	V <sub>IN</sub> =CE=5.0V, V <sub>OUT</sub> =V <sub>OUT</sub> *1.1		70	115	μA
Stand-by Current	I <sub>STN-BY</sub>	V <sub>IN</sub> =5.0V, CE=0V, V <sub>OUT</sub> =V <sub>OUT</sub> *1.1		0	1.0	μA
PFM Switch Current	I <sub>PFM</sub>	CE=V <sub>IN</sub> , I <sub>OUT</sub> =1mA	100	140	180	mA
Current Limit	I <sub>LIM</sub>	V <sub>IN</sub> =CE=5.0V, V <sub>OUT</sub> =0V	600	700		mA
Efficiency (Note 1)	η	CE=V <sub>IN</sub> =4.5V, I <sub>OUT</sub> =100mA		90		%
<b>OSCILLATOR</b>						
Oscillation Frequency	f <sub>OSC</sub>	I <sub>OUT</sub> =100mA	1020	1300	1500	kHz
Maximum Duty Ratio	D <sub>MAX</sub>	CE=V <sub>IN</sub> , V <sub>OUT</sub> =0V	100			%
Minimum Duty Ratio	D <sub>MIN</sub>	CE=V <sub>OUT</sub> =V <sub>IN</sub>			0	%
Soft-Start Time	T <sub>SS</sub>	I <sub>OUT</sub> =1mA	0.5	1.0	3.0	ms
Latch Time	T <sub>LAT</sub>	V <sub>IN</sub> =CE=5.0V (Note 3)	1		20	ms
<b>CE (PIN 3)</b>						
CE "H" Voltage	V <sub>CEH</sub>		0.9		V <sub>IN</sub>	V
CE "L" Voltage	V <sub>CEL</sub>		V <sub>SS</sub>		0.3	V
CE "H" Current	I <sub>CEH</sub>	V <sub>IN</sub> =CE=5.5V, V <sub>OUT</sub> =0V	-0.1		0.1	μA
CE "L" Current	I <sub>CEL</sub>	V <sub>IN</sub> =5.5V, CE=0V, V <sub>OUT</sub> =0V	-0.1		0.1	μA
<b>LX (PIN 5)</b>						
LX SW "H" ON Resistance	R <sub>LXH</sub>	CE=0.5V <sub>IN</sub> , V <sub>OUT</sub> =0V, I <sub>LX</sub> =100mA		0.6		Ω
LX SW "L" ON Resistance	R <sub>LXL</sub>	CE=0.5V <sub>IN</sub> , I <sub>LX</sub> =100mA		0.7		Ω
LX SW "H" Leak Current (Note 2)	I <sub>LEAKH</sub>	V <sub>IN</sub> =V <sub>OUT</sub> =5.0V, CE=0V, LX=0V		0.01	1.0	μA
LX SW "L" Leak Current	I <sub>LEAKL</sub>	V <sub>IN</sub> =V <sub>OUT</sub> =5.0V, CE=0V, LX=5.0V		0.01	1.0	μA

## ■ ELECTRICAL CHARACTERISTICS(Cont.)

### UC3655-28 (V<sub>IN</sub>=3.6V, V<sub>OUT</sub>=2.8V)

PARAMETER	SYMBOL	TEST CONDITIONS	MIN	TYP	MAX	UNIT
Operating Voltage Range	V <sub>IN</sub>		2.0		6.0	V
Output Voltage	V <sub>OUT</sub>	CE=V <sub>IN</sub> , I <sub>OUT</sub> =30mA	2.744	2.8	2.856	V
U.V.L.O. Voltage	V <sub>UVLO</sub>	CE=V <sub>IN</sub> , V <sub>OUT</sub> =0V, LX=L	1.0	1.40	1.78	V
Output Voltage Temperature Characteristics	$\frac{\Delta V_{OUT}}{V_{OUT} \cdot \Delta T_{OPR}}$	I <sub>OUT</sub> =30mA, -40°C ≤ T <sub>OPR</sub> ≤ 85°C		±100		ppm/°C
Maximum Output Current	I <sub>OUT(MAX)</sub>	V <sub>IN</sub> =4.5V	500			mA
Supply Current	I <sub>DD</sub>	V <sub>IN</sub> =CE=5.0V, V <sub>OUT</sub> =V <sub>OUT</sub> *1.1		75	120	μA
Stand-by Current	I <sub>STN-BY</sub>	V <sub>IN</sub> =5.0V, CE=0V, V <sub>OUT</sub> =V <sub>OUT</sub> *1.1		0	1.0	μA
PFM Switch Current	I <sub>PFM</sub>	CE=V <sub>IN</sub> , I <sub>OUT</sub> =1mA	100	140	180	mA
Current Limit	I <sub>LIM</sub>	V <sub>IN</sub> =CE=5.0V, V <sub>OUT</sub> =0V	600	700		mA
Efficiency (Note 1)	η	CE=V <sub>IN</sub> =4.5V, I <sub>OUT</sub> =100mA		92		%

### OSCILLATOR

Oscillation Frequency	f <sub>OSC</sub>	I <sub>OUT</sub> =100mA	1020	1300	1500	kHz
Maximum Duty Ratio	D <sub>MAX</sub>	CE=V <sub>IN</sub> , V <sub>OUT</sub> =0V	100			%
Minimum Duty Ratio	D <sub>MIN</sub>	CE=V <sub>OUT</sub> =V <sub>IN</sub>			0	%
Soft-Start Time	T <sub>SS</sub>	I <sub>OUT</sub> =1mA	0.5	1.0	3.0	ms
Latch Time	T <sub>LAT</sub>	V <sub>IN</sub> =CE=5.0V (Note 3)	1		20	ms

### CE (PIN 3)

CE "H" Voltage	V <sub>CEH</sub>		0.9		V <sub>IN</sub>	V
CE "L" Voltage	V <sub>CEL</sub>		V <sub>SS</sub>		0.3	V
CE "H" Current	I <sub>CEH</sub>	V <sub>IN</sub> =CE=5.5V, V <sub>OUT</sub> =0V	-0.1		0.1	μA
CE "L" Current	I <sub>CEL</sub>	V <sub>IN</sub> =5.5V, CE=0V, V <sub>OUT</sub> =0V	-0.1		0.1	μA

### LX (PIN 5)

LX SW "H" ON Resistance	R <sub>LXH</sub>	CE=0.5V <sub>IN</sub> , V <sub>OUT</sub> =0V, I <sub>LX</sub> =100mA		0.5		Ω
LX SW "L" ON Resistance	R <sub>LXL</sub>	CE=0.5V <sub>IN</sub> , I <sub>LX</sub> =100mA		0.6		Ω
LX SW "H" Leak Current	I <sub>LEAKH</sub>	V <sub>IN</sub> =V <sub>OUT</sub> =5.0V, CE=0V, LX=0V (Note 2)		0.01	1.0	μA
LX SW "L" Leak Current	I <sub>LEAKL</sub>	V <sub>IN</sub> =V <sub>OUT</sub> =5.0V, CE=0V, LX=5.0V		0.01	1.0	μA

### UC3655-33 (V<sub>IN</sub>=5.0V, V<sub>OUT</sub>=3.3V)

PARAMETER	SYMBOL	TEST CONDITIONS	MIN	TYP	MAX	UNIT
Operating Voltage Range	V <sub>IN</sub>		2.0		6.0	V
Output Voltage	V <sub>OUT</sub>	CE=V <sub>IN</sub> , I <sub>OUT</sub> =30mA	3.234	3.300	3.366	V
U.V.L.O. Voltage	V <sub>UVLO</sub>	CE=V <sub>IN</sub> , V <sub>OUT</sub> =0V, LX=L	1.0	1.40	1.78	V
Output Voltage Temperature Characteristics	$\frac{\Delta V_{OUT}}{V_{OUT} \cdot \Delta T_{OPR}}$	I <sub>OUT</sub> =30mA, -40°C ≤ T <sub>OPR</sub> ≤ 85°C		±100		ppm/°C
Maximum Output Current	I <sub>OUT(MAX)</sub>	V <sub>IN</sub> =4.5V	500			mA
Supply Current	I <sub>DD</sub>	V <sub>IN</sub> =CE=5.0V, V <sub>OUT</sub> =V <sub>OUT</sub> *1.1		75	120	μA
Stand-by Current	I <sub>STN-BY</sub>	V <sub>IN</sub> =5.0V, CE=0V, V <sub>OUT</sub> =V <sub>OUT</sub> *1.1		0	1.0	μA
PFM Switch Current	I <sub>PFM</sub>	CE=V <sub>IN</sub> , I <sub>OUT</sub> =1mA	100	140	180	mA
Current Limit	I <sub>LIM</sub>	V <sub>IN</sub> =CE=5.0V, V <sub>OUT</sub> =0V	600	700		mA
Efficiency (Note 1)	η	CE=V <sub>IN</sub> =4.5V, I <sub>OUT</sub> =100mA		92		%

### OSCILLATOR

Oscillation Frequency	f <sub>OSC</sub>	I <sub>OUT</sub> =100mA	1020	1300	1500	kHz
Maximum Duty Ratio	D <sub>MAX</sub>	CE=V <sub>IN</sub> , V <sub>OUT</sub> =0V	100			%
Minimum Duty Ratio	D <sub>MIN</sub>	CE=V <sub>OUT</sub> =V <sub>IN</sub>			0	%
Soft-Start Time	T <sub>SS</sub>	I <sub>OUT</sub> =1mA	0.5	1.0	3.0	ms
Latch Time	T <sub>LAT</sub>	V <sub>IN</sub> =CE=5.0V (Note 3)	1		20	ms

## ■ ELECTRICAL CHARACTERISTICS(Cont.)

PARAMETER	SYMBOL	TEST CONDITIONS	MIN	TYP	MAX	UNIT
<b>CE (PIN 3)</b>						
CE "H" Voltage	$V_{CEH}$		0.9		$V_{IN}$	V
CE "L" Voltage	$V_{CEL}$		$V_{SS}$		0.3	V
CE "H" Current	$I_{CEH}$	$V_{IN}=CE=5.5V, V_{OUT}=0V$	-0.1		0.1	$\mu A$
CE "L" Current	$I_{CEL}$	$V_{IN}=5.5V, CE=0V, V_{OUT}=0V$	-0.1		0.1	$\mu A$
<b>LX (PIN 5)</b>						
LX SW "H" ON Resistance	$R_{LXH}$	$CE=0.5V_{IN}, V_{OUT}=0V, I_{LX}=100mA$		0.5		$\Omega$
LX SW "L" ON Resistance	$R_{LXL}$	$CE=0.5V_{IN}, I_{LX}=100mA$		0.6		$\Omega$
LX SW "H" Leak Current (Note 2)	$I_{LEAKH}$	$V_{IN}=V_{OUT}=5.0V, CE=0V, LX=0V$		0.01	1.0	$\mu A$
LX SW "L" Leak Current	$I_{LEAKL}$	$V_{IN}=V_{OUT}=5.0V, CE=0V, LX=5.0V$		0.01	1.0	$\mu A$

### UC3655-38 ( $V_{IN}=5.0V, V_{OUT}=3.8V$ )

PARAMETER	SYMBOL	TEST CONDITIONS	MIN	TYP	MAX	UNIT
Operating Voltage Range	$V_{IN}$		2.0		6.0	V
Output Voltage	$V_{OUT}$	$CE=V_{IN}, I_{OUT}=30mA$	3.724	3.800	3.876	V
U.V.L.O. Voltage	$V_{UVLO}$	$CE=V_{IN}, V_{OUT}=0V, LX=L$	1.0	1.40	1.78	V
Output Voltage Temperature Characteristics	$\frac{\Delta V_{OUT}}{V_{OUT} \cdot \Delta T_{OPR}}$	$I_{OUT}=30mA, -40^{\circ}C \leq T_{OPR} \leq 85^{\circ}C$		$\pm 100$		ppm/ $^{\circ}C$
Maximum Output Current	$I_{OUT(MAX)}$	$V_{IN}=4.5V$	500			mA
Supply Current	$I_{DD}$	$V_{IN}=CE=5.0V, V_{OUT}=V_{OUT} \cdot 1.1$		75	120	$\mu A$
Stand-by Current	$I_{STN-BY}$	$V_{IN}=5.0V, CE=0V, V_{OUT}=V_{OUT} \cdot 1.1$		0	1.0	$\mu A$
PFM Switch Current	$I_{PFM}$	$CE=V_{IN}, I_{OUT}=1mA$	100	140	180	mA
Current Limit	$I_{LIM}$	$V_{IN}=CE=5.0V, V_{OUT}=0V$	600	700		mA
Efficiency (Note 1)	$\eta$	$CE=V_{IN}=4.5V, I_{OUT}=100mA$		92		%

### OSCILLATOR

Oscillation Frequency	$f_{OSC}$	$I_{OUT}=100mA$	1020	1300	1500	kHz
Maximum Duty Ratio	$D_{MAX}$	$CE=V_{IN}, V_{OUT}=0V$	100			%
Minimum Duty Ratio	$D_{MIN}$	$CE=V_{OUT}=V_{IN}$			0	%
Soft-Start Time	$T_{SS}$	$I_{OUT}=1mA$	0.5	1.0	3.0	ms
Latch Time	$T_{LAT}$	$V_{IN}=CE=5.0V$ (Note 3)	1		20	ms

### CE (PIN 3)

CE "H" Voltage	$V_{CEH}$		0.9		$V_{IN}$	V
CE "L" Voltage	$V_{CEL}$		$V_{SS}$		0.3	V
CE "H" Current	$I_{CEH}$	$V_{IN}=CE=5.5V, V_{OUT}=0V$	-0.1		0.1	$\mu A$
CE "L" Current	$I_{CEL}$	$V_{IN}=5.5V, CE=0V, V_{OUT}=0V$	-0.1		0.1	$\mu A$

### LX (PIN 5)

LX SW "H" ON Resistance	$R_{LXH}$	$CE=0.5V_{IN}, V_{OUT}=0V, I_{LX}=100mA$		0.5		$\Omega$
LX SW "L" ON Resistance	$R_{LXL}$	$CE=0.5V_{IN}, I_{LX}=100mA$		0.6		$\Omega$
LX SW "H" Leak Current (Note 2)	$I_{LEAKH}$	$V_{IN}=V_{OUT}=5.0V, CE=0V, LX=0V$		0.01	1.0	$\mu A$
LX SW "L" Leak Current	$I_{LEAKL}$	$V_{IN}=V_{OUT}=5.0V, CE=0V, LX=5.0V$		0.01	1.0	$\mu A$

Note: 1.  $\eta = [(V_{OUT} \cdot I_{OUT}) / (V_{IN} \cdot I_{IN})] \cdot 100$

2. When temperature is high, a current of approximately 20 $\mu A$  (maximum) may leak.

3. Time until it short-circuits DCOUT with GND through 1 $\Omega$  of resistance from a state of operation and is set to DCOUT=0V from current limit pulse generating.

## OPERATIONAL EXPLANATION

### CE / MODE Pin Function

When a low level signal is input to the CE/MODE pin the operation of the **UC3655** series will enter into the shut down mode. In this mode, the current consumption occurs only in the detector and is 0  $\mu$ A (TYP.), with a state of high impedance at the Lx pin and VOUT pin. By inputting a high level signal to the CE/MODE pin the IC starts its operation. The input of the CE/MODE pin is a CMOS input and its sink current is 0  $\mu$ A (TYP.).

**UC3655** series - Examples of how to use CE/MODE pin

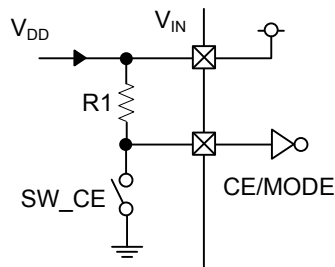

SW_CE	STATUS
ON	Stand-by
OFF	Operation

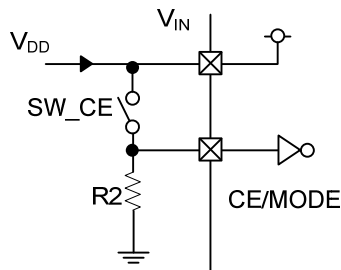

SW_CE	STATUS
ON	Operation
OFF	Stand-by

## FUNCTIONS

### CE/MODE

VOLTAGE LEVEL		OPERATION
H Level	$V_{IN}-0.3V \cong H \text{ level} \cong V_{IN}$	Synchronous PWM/PFM Automatic Switching Control
M Level	$0.9V \cong M \text{ Level} \cong V_{IN}-1.0V$	
L Level	$0V \cong L \text{ Level} \cong 0.3V$	Stand-by

## ■ TEST CIRCUIT

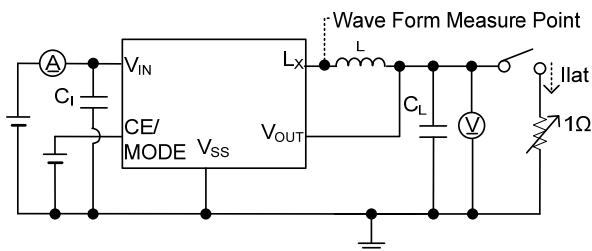
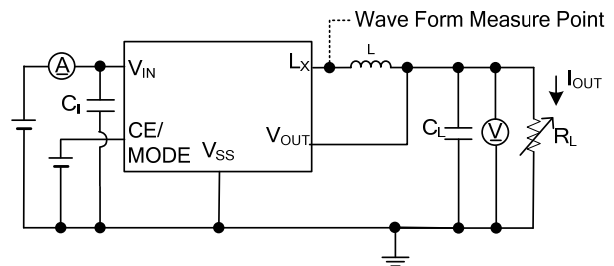
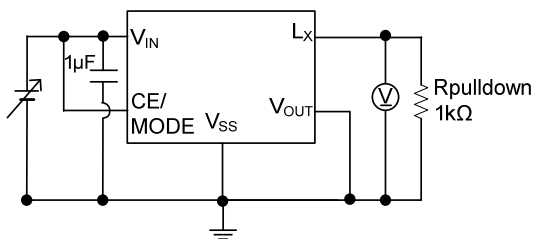
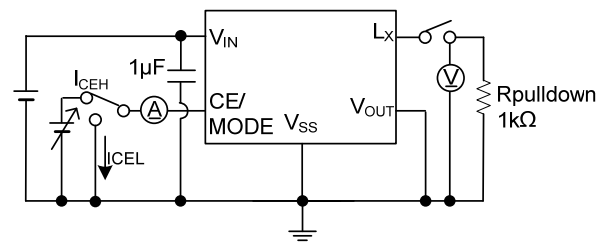
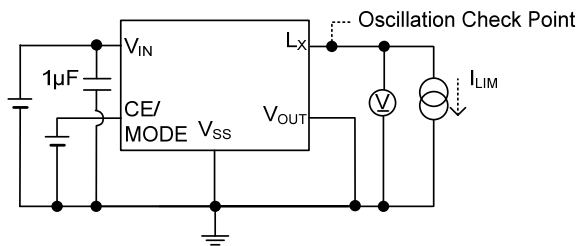
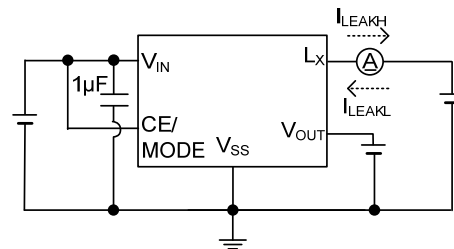
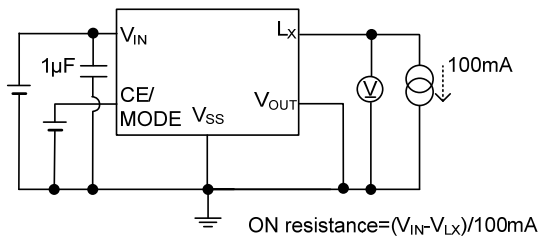
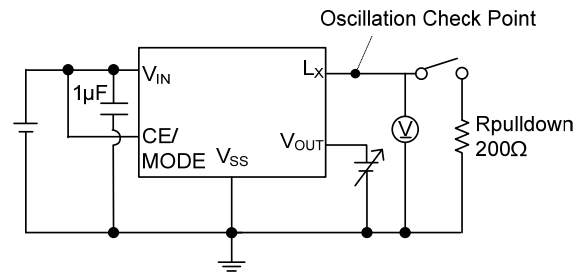
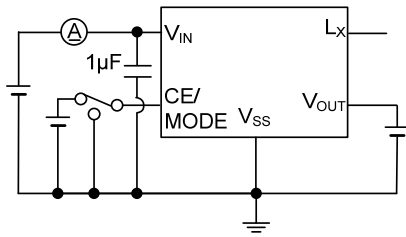

$C_1$	4.7µF (Ceramic)
$C_L$	10µF (Ceramic)
$L$	3.3µH

■ TYPICAL APPLICATION CIRCUIT

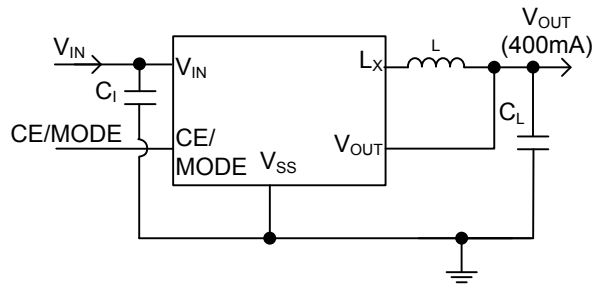

$C_I$	4.7 $\mu$ F (Ceramic)
$C_L$	10 $\mu$ F (Ceramic)
L	3.3 $\mu$ H



■ TYPICAL CHARACTERISTICS

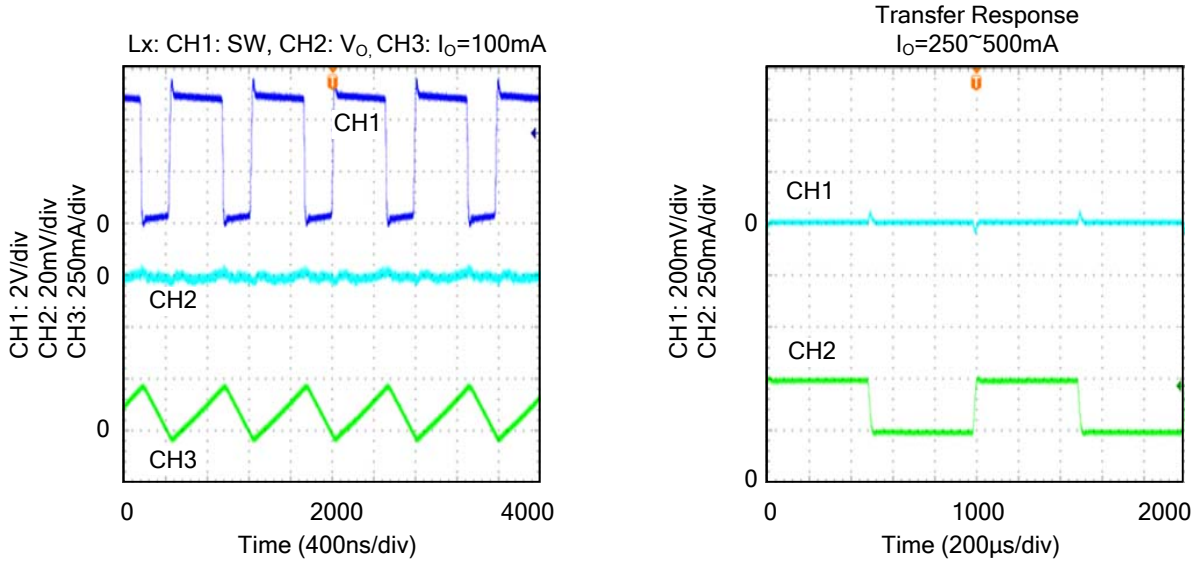

UTC assumes no responsibility for equipment failures that result from using products at values that exceed, even momentarily, rated values (such as maximum ratings, operating condition ranges, or other parameters) listed in products specifications of any and all UTC products described or contained herein. UTC products are not designed for use in life support appliances, devices or systems where malfunction of these products can be reasonably expected to result in personal injury. Reproduction in whole or in part is prohibited without the prior written consent of the copyright owner. The information presented in this document does not form part of any quotation or contract, is believed to be accurate and reliable and may be changed without notice.