



PSR SINGLE-STAGE APFC OFFLINE LED DRIVER

DESCRIPTION

The UTC **UCL2300** is a high precision primary-side regulation controller with single stage Active PFC, specially designed for universal input offline flyback or buck-boost constant current LED lighting. The controller with on-chip PFC circuit achieves high power factor and low THD. Operating in critical conduction mode, the power MOSFET switching loss is reduced and the inductor is fully utilized.

The UTC **UCL2300** adopts proprietary primary side current sensing scheme. It can precisely control the LED current without secondary side sense and feedback circuits. The system size and cost are optimized, as well as the system reliability.

The UTC **UCL2300** utilizes patented line and load voltage compensation method to achieve excellent line and load regulation. And the line compensation factor can also be tuned externally for flexibility.

The UTC **UCL2300** offers rich protection functions to improve the system reliability, including LED open circuit protection, LED short circuit protection, V_{CC} over voltage protection, V_{CC} under voltage protection, CS resistor open protection and cycle by cycle current limit. All the protection functions are auto-recovery.

FEATURES

- * Single-stage active PFC for high power factor and low THD
- * Primary side control constant current operation, No opto-coupler required
- * Ultrafast LED start (<200ms @85V)
- * $\pm 3\%$ LED current accuracy
- * Excellent line and load regulation
- * Critical conduction mode operation
- * Source driving method
- * Ultra-low (20 μ A) startup current
- * Ultra-low (600 μ A) Operating current
- * High resistance feedback resistor for improved efficiency
- * LED open and short circuit protection
- * CS resistor open and short circuit protection
- * Transformer saturation protection
- * Cycle-by-cycle current limit
- * V_{CC} over-voltage and under-voltage protection
- * Auto fault recovery

ORDERING INFORMATION

Ordering Number		Package	Packing
Lead Free	Halogen Free		
UCL2300L-S08-R	UCL2300G-S08-R	SOP-8	Tape Reel

<p>UCL2300G-S08-R</p> <p>(1)Packing Type</p> <p>(2)Package Type</p> <p>(3)Green Package</p>	<p>(1) R: Tape Reel</p> <p>(2) S08: SOP-8</p> <p>(3) G: Halogen Free and Lead Free, L: Lead Free</p>
---	--

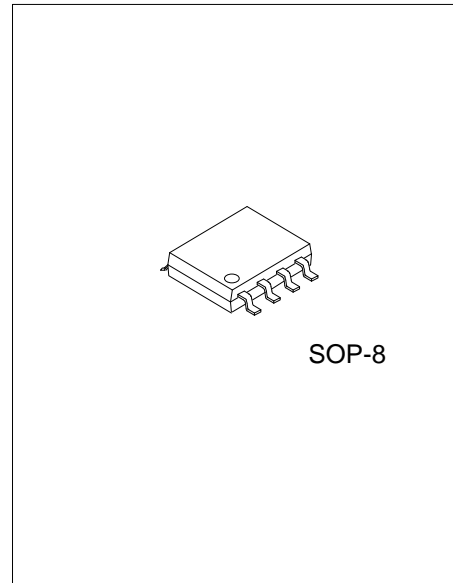

SOP-8

MARKING

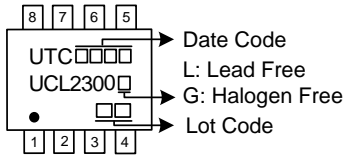

PIN CONFIGURATION

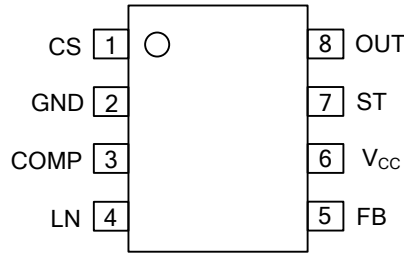

PIN DESCRIPTION

PIN NO.	PIN NAME	DESCRIPTION
1	CS	Current sense pin. Connect a resistor to GND to sense the power MOSFET current.
2	GND	Ground.
3	COMP	Loop compensation node.
4	LN	Line voltage sample input.
5	FB	Feedback voltage input Pin.
6	V _{CC}	Power supply pin.
7	ST	Chip enable pin.
8	OUT	Pulse out pin. Connected to the 'Source' of external power MOSFET.

BLOCK DIAGRAM

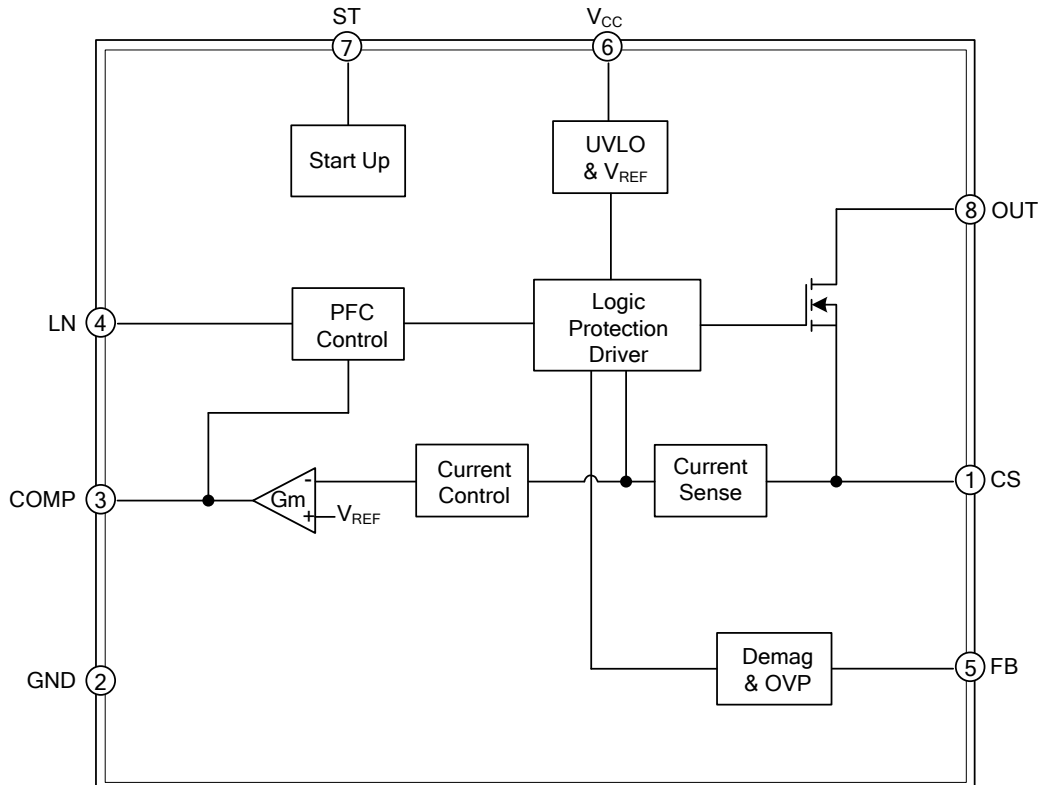

■ ABSOLUTE MAXIMUM RATING

PARAMETER	SYMBOL	RATINGS	UNIT
V _{CC} Pin Input Voltage	V _{CC}	-0.3 ~ 22	V
Current Sense Pin Input Voltage	CS	-0.3 ~ 6	V
Compensation Pin Voltage	COMP	-0.3 ~ 6	V
Line Voltage Sample Input	LN	-0.3 ~ 6	V
Feedback Pin Input Voltage	FB	-0.3 ~ 6	V
ST Pin Maximum Supply Current	I _{ST_MAX}	5	mA
External Power MOSFET Drive Voltage	OUT	-0.3 ~ 18	V
Maximum Work Current of Internal Power MOSFET	I _{OUT}	3	A
Power Dissipation (Note 1)	P _D	0.45	W
Junction Temperature	T _J	-40 ~ +150	°C
Storage Temperature	T _{STG}	-55 ~ +150	°C

Notes: 1. Absolute maximum ratings are those values beyond which the device could be permanently damaged.

Absolute maximum ratings are stress ratings only and functional device operation is not implied.

2. The maximum power dissipation decrease if temperature rise, it is decided by T_{JMAX}, θ_{JA}, and environment temperature (T_A). The maximum power dissipation is the lower one between P_{DMAX}=(T_{JMAX}-T_A)/ θ_{JA} and the number listed in the maximum table.

■ RECOMMENDED OPERATION CONDITIONS

PARAMETER	SYMBOL	RATINGS	UNIT
Power Supply Voltage	V _{CC}	11.5 ~ 17.5	V

■ THERMAL CHARACTERISTICS

PARAMETER	SYMBOL	RATING	UNIT
Junction to Ambient	θ _{JA}	145	°C/W

■ **ELECTRICAL CHARACTERISTICS** (Notes 1, 2) (Unless otherwise specified, $V_{CC}=14V$ and $T_A=25^{\circ}C$)

PARAMETER	SYMBOL	TEST CONDITIONS	MIN	TYP	MAX	UNIT
Startup Voltage						
V_{ST} Startup Voltage	V_{ST_ON}	1mA, $V_{CC}=10V$	16	17	18	V
V_{ST} Hysteresis Voltage	V_{ST_HYS}	$V_{CC}=14V$		1.6		V
ST Startup Current	I_{ST_ON}	$V_{CC}=10V$		20	35	μA
ST Operating Current	I_{ST_OP}	$V_{CC}=14V$		35	60	μA
Supply Voltage Section						
V_{CC} Startup Voltage	V_{CC_ON}	V_{CC} Rising	10	11	12	V
V_{CC} Undervoltage Protection Threshold	V_{CC_UVLO}	V_{CC} Falling	5.2	5.8	6.5	V
V_{CC} Hold Voltage	V_{CC_HOLD}	V_{CC} Falling	7	7.5	8	V
V_{CC} Turn Off Current	I_{CC_UVLO}	V_{CC} Rising, $V_{CC}=10V$		40	70	μA
V_{CC} Quiescent Current	I_Q	No Switch, $V_{CC}=14V$		320	600	μA
V_{CC} Operating Current	I_{CC}	$F_{OP}=60kHz$		600		μA
V_{CC} Over Voltage Protection Threshold	V_{CC_OVP}			20		V
FB Feedback						
FB Falling Edge Threshold Voltage	V_{FB_FALL}	FB Falling		0.4		V
FB Hysteresis Voltage	V_{FB_HYS}	FB Rising		0.6		V
FB Over Voltage Protection Threshold	V_{FB_OVP}			5.5		V
Minimum Off Time	T_{OFF_MIN}			4.0		μs
Maximum Off Time	T_{OFF_MAX}			150		μs
Current Sense Section						
Leading Edge Blanking Time for Current Sense	T_{LEB_CS}			350		ns
Switch off Delay Time	T_{DELAY}			180		ns
Loop Compensation						
Internal Reference Voltage	V_{REF}		0.294	0.300	0.306	V
COMP Low Clamp Voltage	V_{COMP_LO}			1.5		V
COMP Linear Operating Voltage Range	V_{COMP}		1.5		3.5	V
COMP Protection Threshold	V_{COMP_OVP}			4.5		V
Linear Voltage Sampling						
LN Linear Working Range	V_{LN}		0		2.5	V
Driver Stage						
Internal Tube Driven MOS Resistance	R_{DS_ON}	$V_{CC}=14V$		1000		m Ω

Notes: 1. Production testing of the chip is performed at 25°C.

2. The maximum and minimum parameters specified are guaranteed by test, the typical value are guaranteed by design, characterization and statistical analysis

■ TYPICAL APPLICATION CIRCUIT

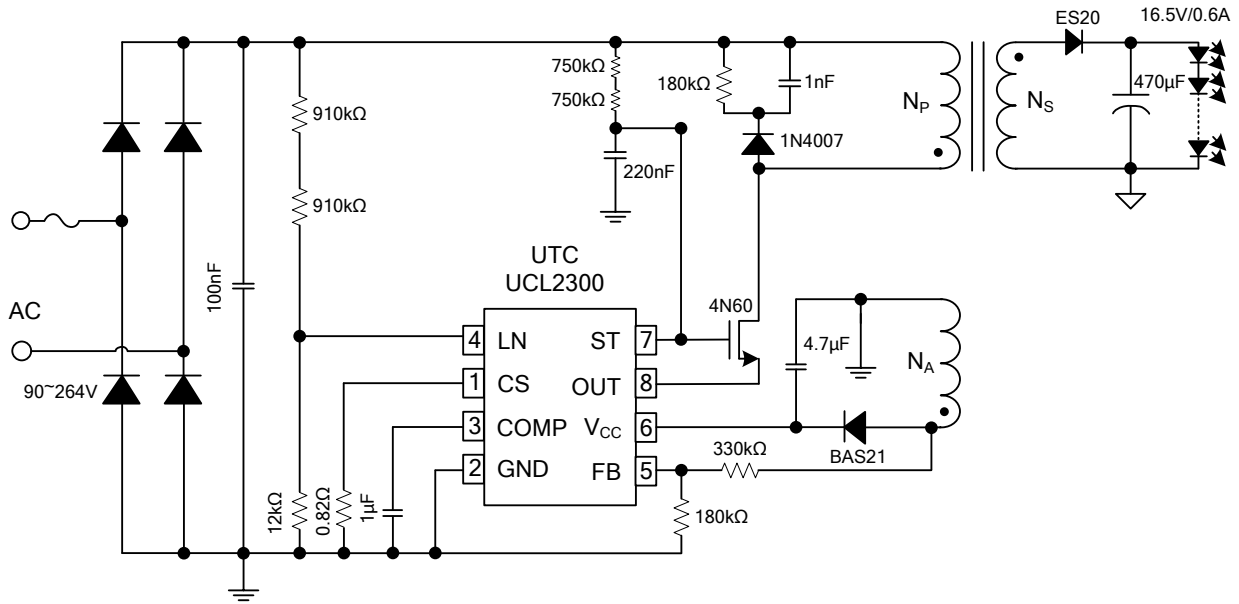

UTC assumes no responsibility for equipment failures that result from using products at values that exceed, even momentarily, rated values (such as maximum ratings, operating condition ranges, or other parameters) listed in products specifications of any and all UTC products described or contained herein. UTC products are not designed for use in life support appliances, devices or systems where malfunction of these products can be reasonably expected to result in personal injury. Reproduction in whole or in part is prohibited without the prior written consent of the copyright owner. UTC reserves the right to make changes to information published in this document, including without limitation specifications and product descriptions, at any time and without notice. This document supersedes and replaces all information supplied prior to the publication hereof.