



UD22K

Preliminary

DUAL TRANSISTOR

DIGITAL TRANSISTOR (BUILT-IN RESISTORS)

DESCRIPTION

The UTC UD22K is a dual transistor, including an NPN transistor and a PNP transistor.

FEATURES

- * Built-in bias resistors that implies easy ON/OFF applications.
- * The bias resistors are thin-film resistors with complete isolation to allow positive input.

EQUIVALENT CIRCUITS

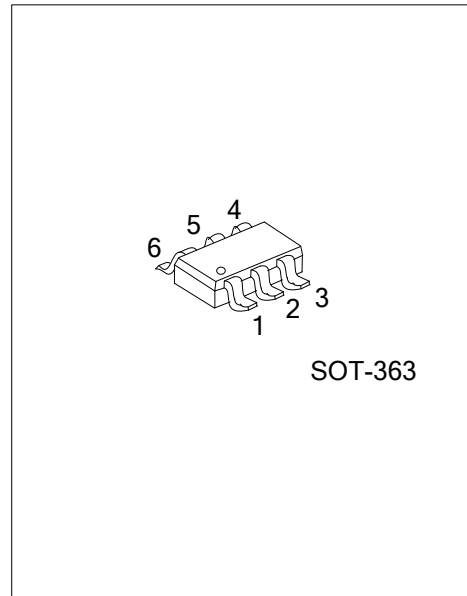
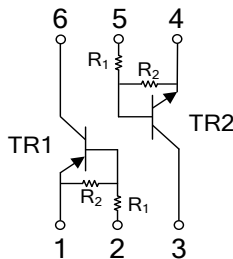

ORDERING INFORMATION

Ordering Number		Package	Pin Assignment						Packing
Lead Free	Halogen Free		1	2	3	4	5	6	
UD22KL-AL6-R	UD22KG-AL6-R	SOT-363	G1	I1	O2	G2	I2	O1	Tape Reel

Note: Pin Assignment: G: GND I: IN O: OUT

<p>UD22KG-AL6-R</p> <p>(1)Packing Type (2)Package Type (3)Green Package</p>	<p>(1) R: Tape Reel (2) AL6: SOT-363 (3) G: Halogen Free and Lead Free, L: Lead Free</p>
---	--

MARKING

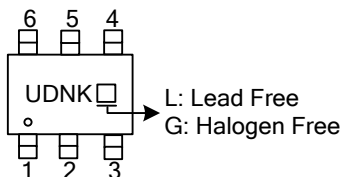

■ **ABSOLUTE MAXIMUM RATINGS** ($T_A=25^\circ\text{C}$, unless otherwise specified)

PARAMETER	SYMBOL	LIMITS		UNIT
		TR1	TR2	
Collector-Emitter Voltage	V_{CEO}	-50	50	V
Collector-Base Voltage	V_{CBO}	-30 ~ + 5	-5 ~ + 30	V
Emitter-Base Voltage	V_{EBO}	-100	100	mA
Collector Current - Continuous	I_C	-100	100	mA
Junction Temperature	T_J	+150		$^\circ\text{C}$
Storage Temperature	T_{STG}	-55 ~ +150		$^\circ\text{C}$

Note: Absolute maximum ratings are those values beyond which the device could be permanently damaged. Absolute maximum ratings are stress ratings only and functional device operation is not implied.

■ **THERMAL DATA**

PARAMETER	SYMBOL	RATINGS	UNIT
Junction to Ambient	θ_{JA}	415	$^\circ\text{C/W}$

■ **ELECTRICAL CHARACTERISTICS** ($T_A=25^\circ\text{C}$, unless otherwise specified)

TR1

PARAMETER	SYMBOL	TEST CONDITIONS	MIN	TYP	MAX	UNIT
OFF CHARACTERISTICS						
Input Voltage	$V_{IN(OFF)}$	$V_{CC}=-5V, I_{OUT}=-100\mu\text{A}$			-0.5	V
	$V_{IN(ON)}$	$V_{OUT}=-0.3V, I_{OUT}=-5\text{mA}$	-1.3			V
Output Voltage	$V_{OUT(ON)}$	$I_{OUT}/I_{IN}=-5\text{mA}/-0.25\text{mA}$		-0.1	-0.3	V
Input Current	I_{IN}	$V_{IN}=-5V$			-1.8	mA
Output Current	$I_{O(OFF)}$	$V_{CC}=-50V, V_{IN}=0V$			-0.5	μA
ON CHARACTERISTICS						
DC Current Gain	h_{FE}	$V_{OUT}=5V, I_{OUT}=10\text{mA}$	80			
SMALL SIGNAL CHARACTERISTICS						
Transition Frequency	f_T	$V_{CE}=-10V, I_E=-5\text{mA}, f=100\text{MHz}$ (Note 1)		250		MHz
Input Resistance	R_1		3.29	4.7	6.11	K Ω
Resistance Ratio	R_2/R_1		8	10	12	

TR2

PARAMETER	SYMBOL	TEST CONDITIONS	MIN	TYP	MAX	UNIT
OFF CHARACTERISTICS						
Input Voltage	$V_{IN(OFF)}$	$I_C=100\mu\text{A}, I_B=0$			0.5	V
	$V_{IN(ON)}$	$I_C=10\mu\text{A}, I_E=0$	1.3			V
Output Voltage	$V_{OUT(ON)}$	$I_E=10\mu\text{A}, I_C=0$		0.1	0.3	V
Input Current	I_{IN}	$V_{IN}=5V$			1.8	mA
Output Current	$I_{O(OFF)}$	$V_{CC}=50V, V_{IN}=0V$			0.5	μA
ON CHARACTERISTICS						
DC Current Gain	h_{FE}	$V_{OUT}=5V, I_{OUT}=10\text{mA}$	80			
SMALL SIGNAL CHARACTERISTICS						
Transition Frequency	f_T	$V_{CE}=-10V, I_E=-5\text{mA}, f=100\text{MHz}$ (Note 1)		250		MHz
Input Resistance	R_1		3.29	4.7	6.11	K Ω
Resistance Ratio	R_2/R_1		8	10	12	

Note: Transition frequency of the device.

UTC assumes no responsibility for equipment failures that result from using products at values that exceed, even momentarily, rated values (such as maximum ratings, operating condition ranges, or other parameters) listed in products specifications of any and all UTC products described or contained herein. UTC products are not designed for use in life support appliances, devices or systems where malfunction of these products can be reasonably expected to result in personal injury. Reproduction in whole or in part is prohibited without the prior written consent of the copyright owner. UTC reserves the right to make changes to information published in this document, including without limitation specifications and product descriptions, at any time and without notice. This document supersedes and replaces all information supplied prior to the publication hereof.