



UD4614

Power MOSFET

DUAL ENHANCEMENT MODE (N-CHANNEL/P-CHANNEL)

DESCRIPTION

The UTC **UD4614** can provide excellent $R_{DS(ON)}$ and low gate charge by using advanced trench technology MOSFETs. The UTC **UD4614** may be used in H-bridge, inverters and other applications.

FEATURES

- * N-Channel: 40V/6A
 $R_{DS(ON)} \leq 23.2 \text{ m}\Omega$ (typ.) @ $V_{GS} = 10V$
 $R_{DS(ON)} \leq 32.6 \text{ m}\Omega$ (typ.) @ $V_{GS} = 4.5V$
- * P-Channel: -40V/-5A
 $R_{DS(ON)} \leq 34.7 \text{ m}\Omega$ (typ.) @ $V_{GS} = -10V$
 $R_{DS(ON)} \leq 50.6 \text{ m}\Omega$ (typ.) @ $V_{GS} = -4.5V$
- * Super high dense cell design
- * Reliable and Rugged

SYMBOL

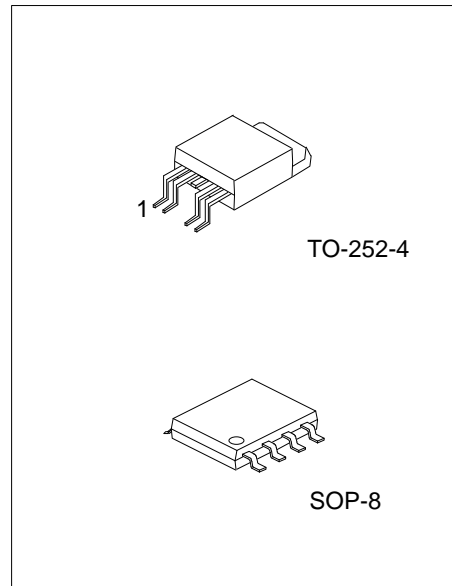
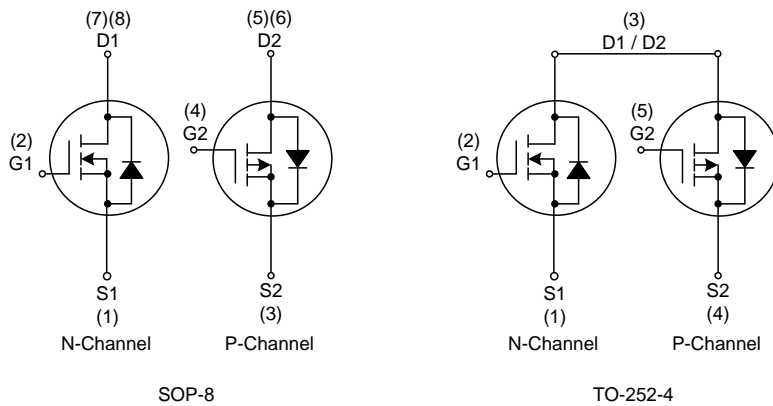

ORDERING INFORMATION

Ordering Number		Package	Packing
Lead Free	Halogen Free		
UD4614L-TN4-R	UD4614G-TN4-R	TO-252-4	Tape Reel
UD4614L-S08-R	UD4614G-S08-R	SOP-8	Tape Reel

<p>UD4614G-TN4-R</p> <p>(1) Packing Type (2) Package Type (3) Green Package</p>	<p>(1) R: Tape Reel (2) TN4: TO-252-4, S08: SOP-8 (3) G: Halogen Free and Lead Free, L: Lead Free</p>
---	---

MARKING

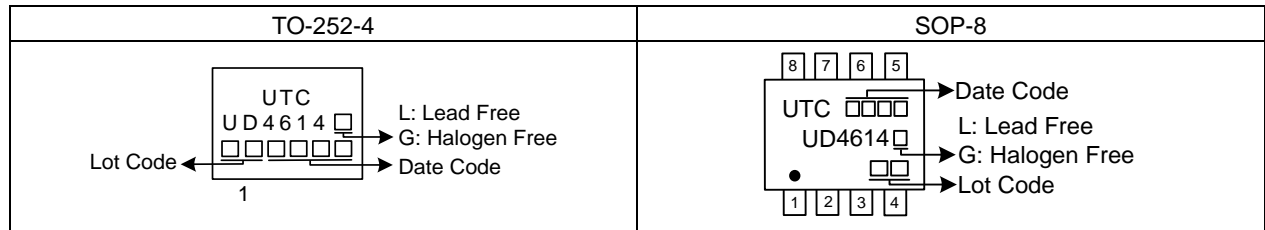

PIN CONFIGURATION

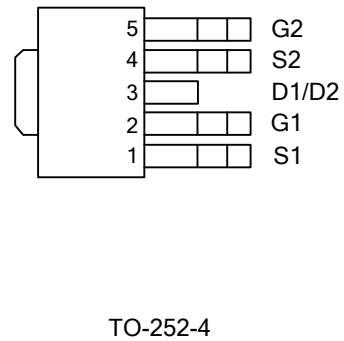
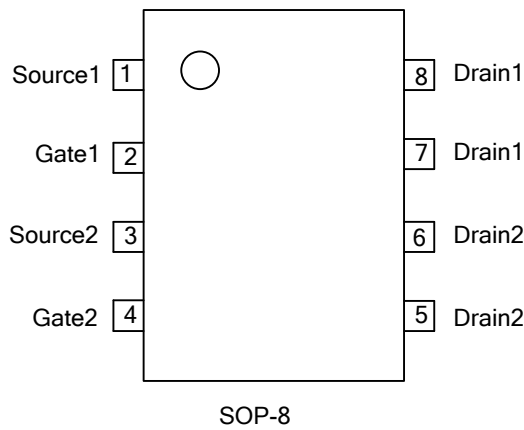

■ **ABSOLUTE MAXIMUM RATINGS** ($T_A = 25^\circ\text{C}$, unless otherwise specified)

N-Channel:

PARAMETER		SYMBOL	RATINGS	UNIT	
Drain-Source Voltage		V_{DS}	40	V	
Gate-Source Voltage		V_{GS}	± 20	V	
Continuous Drain Current (Note3)	Continuous	I_D	6.1	A	
Pulsed Drain Current (Note3)		I_{DM}	24	A	
Power Dissipation	$T_A = 25^\circ\text{C}$	TO-252-4	P_D	3.125	W
		SOP-8		2	W
	$T_A = 70^\circ\text{C}$	TO-252-4		2	W
		SOP-8		1.28	W
Junction Temperature		T_J	-55 ~ +150	$^\circ\text{C}$	
Storage Temperature		T_{STG}	-55 ~ +150	$^\circ\text{C}$	

P-Channel:

PARAMETER		SYMBOL	RATINGS	UNIT	
Drain-Source Voltage		V_{DS}	-40	V	
Gate-Source Voltage		V_{GS}	± 20	V	
Continuous Drain Current (Note3)	Continuous	I_D	-5.2	A	
Pulsed Drain Current (Note3)		I_{DM}	-24	A	
Power Dissipation	$T_A = 25^\circ\text{C}$	TO-252-4	P_D	3.125	W
		SOP-8		2	W
	$T_A = 70^\circ\text{C}$	TO-252-4		2	W
		SOP-8		1.28	W
Junction Temperature		T_J	-55 ~ +150	$^\circ\text{C}$	
Storage Temperature		T_{STG}	-55 ~ +150	$^\circ\text{C}$	

Note: Absolute maximum ratings are those values beyond which the device could be permanently damaged.

Absolute maximum ratings are stress ratings only and functional device operation is not implied.

■ **THERMAL CHARACTERISTICS**

PARAMETER		SYMBOL	RATINGS	UNIT
Junction to Ambient	TO-252-4	θ_{JA}	40	$^\circ\text{C/W}$
	SOP-8		62.5	

Note: Surface Mounted on 1in^2 pad area, $t \leq 10$ sec.

■ **ELECTRICAL CHARACTERISTICS** ($T_J=25^\circ\text{C}$, unless otherwise specified)

N-CHANNEL

PARAMETER	SYMBOL	TEST CONDITIONS	MIN	TYP	MAX	UNIT
OFF CHARACTERISTICS						
Drain-Source Breakdown Voltage	BV_{DSS}	$V_{GS}=0V, I_D=10mA$	40			V
Drain-Source Leakage Current	I_{DSS}	$V_{DS}=32V, V_{GS}=0V$			1	μA
Gate-Source Leakage Current	I_{GSS}	$V_{DS}=0V, V_{GS}=\pm 20V$			± 100	nA
ON CHARACTERISTICS						
Gate Threshold Voltage	$V_{GS(TH)}$	$V_{DS}=V_{GS}, I_D=250\mu A$	1	2.3	3	V
Drain-Source On-State Resistance (Note2)	$R_{DS(ON)}$	$V_{GS}=10V, I_D=6A$		23.2	31	m Ω
		$V_{GS}=4.5V, I_D=5A$		32.6	45	m Ω
DYNAMIC CHARACTERISTICS						
Input Capacitance	C_{ISS}	$V_{GS}=0V, V_{DS}=20V, f=1.0MHz$		780		pF
Output Capacitance	C_{OSS}			110		pF
Reverse Transfer Capacitance	C_{RSS}			86		pF
SWITCHING CHARACTERISTICS						
Total Gate Charge (Note2)	Q_G	$V_{DS}=20V, V_{GS}=10V, I_D=6A$		95		nC
Gate-Source Charge	Q_{GS}			6.3		nC
Gate-Drain Charge	Q_{GD}			6.3		nC
Turn-ON Delay Time (Note2)	$t_{D(ON)}$	$V_{DS}=20V, V_{GS}=10V, R_G=3\Omega, I_D=1A$		32		ns
Turn-ON Rise Time	t_R			40		ns
Turn-OFF Delay Time	$t_{D(OFF)}$			172		ns
Turn-OFF Fall Time	t_F			64		ns
SOURCE- DRAIN DIODE RATINGS AND CHARACTERISTICS						
Diode Continuous Forward Current	I_S				3	A
Drain-Source Diode Forward Voltage(Note2)	V_{SD}	$I_S=1A, V_{GS}=0V$		0.77	1	V
Reverse Recovery Time	t_{rr}	$I_{DS}=6A, di/dt=100A/\mu s$		20.5		ns
Reverse Recovery Charge	Q_{rr}			14.5		nC

■ ELECTRICAL CHARACTERISTICS (Cont.)

P-CHANNEL

PARAMETER	SYMBOL	TEST CONDITIONS	MIN	TYP	MAX	UNIT
OFF CHARACTERISTICS						
Drain-Source Breakdown Voltage	BV_{DSS}	$V_{GS}=0V, I_D=-10mA$	-40			V
Drain-Source Leakage Current	I_{DSS}	$V_{DS}=-32V, V_{GS}=0V$			-1	μA
Gate-Source Leakage Current	I_{GSS}	$V_{DS}=0V, V_{GS}=\pm 20V$			± 100	nA
ON CHARACTERISTICS						
Gate Threshold Voltage	$V_{GS(TH)}$	$V_{DS}=V_{GS}, I_D=-250\mu A$	-1	-1.9	-3	V
Drain-Source On-State Resistance (Note2)	$R_{DS(ON)}$	$V_{GS}=-10V, I_D=-5A$		34.7	45	m Ω
		$V_{GS}=-4.5V, I_D=-2A$		50.6	63	m Ω
DYNAMIC CHARACTERISTICS						
Input Capacitance	C_{ISS}	$V_{GS}=0V, V_{DS}=-20V, f=1.0MHz$		1120		pF
Output Capacitance	C_{OSS}			115		pF
Reverse Transfer Capacitance	C_{RSS}			91		pF
SWITCHING CHARACTERISTICS						
Turn-ON Delay Time (Note2)	$t_{D(ON)}$	$V_{DS}=-20V, V_{GS}=-10V,$ $R_G=3\Omega, I_D=1A$		34		ns
Turn-ON Rise Time	t_R			48		ns
Turn-OFF Delay Time	$t_{D(OFF)}$			224		ns
Turn-OFF Fall Time	t_F			108		ns
Total Gate Charge (Note2)	Q_G	$V_{DS}=-20V, V_{GS}=-10V, I_D=-5A$		90		nC
Gate-Source Charge	Q_{GS}			5.8		nC
Gate-Drain Charge	Q_{GD}			5.3		nC
SOURCE- DRAIN DIODE RATINGS AND CHARACTERISTICS						
Drain-Source Diode Forward Voltage(Note2)	V_{SD}	$I_S=-1A, V_{GS}=0V$		-0.75	-1	V
Diode Continuous Forward Current	I_S				-3.2	A
Reverse Recovery Time	t_{RR}	$I_{DS}=-5A, dI/dt=100A/\mu s$		22.3		ns
Reverse Recovery Charge	Q_{RR}				15.2	

- Notes: 1. Pulse width limited by $T_{J(MAX)}$
 2. Pulse width $\leq 300\mu s$, duty cycle $\leq 2\%$.
 3. Surface Mounted on $1in^2$ pad area, $t \leq 10sec$.

TYPICAL CHARACTERISTICS

N-CHANNEL

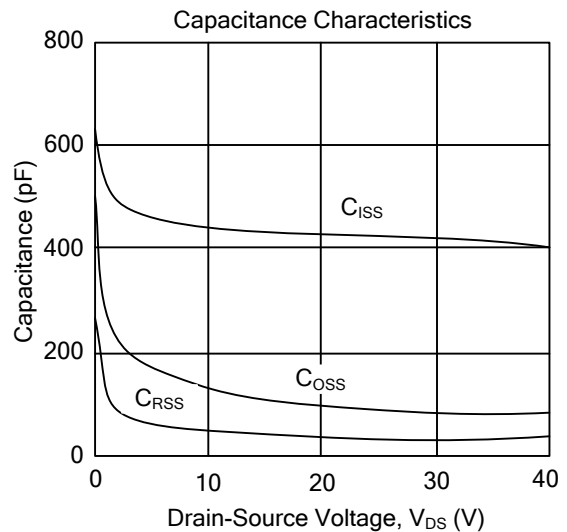
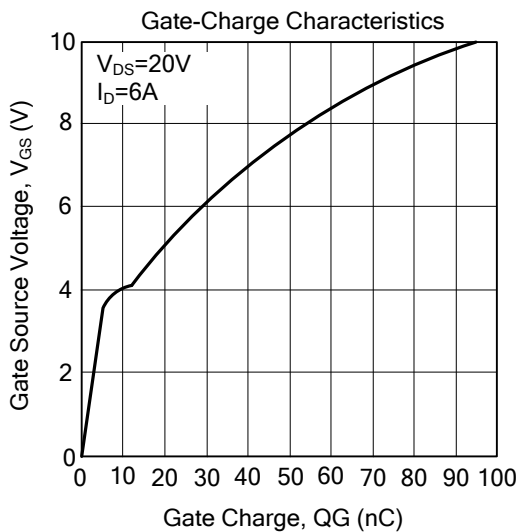
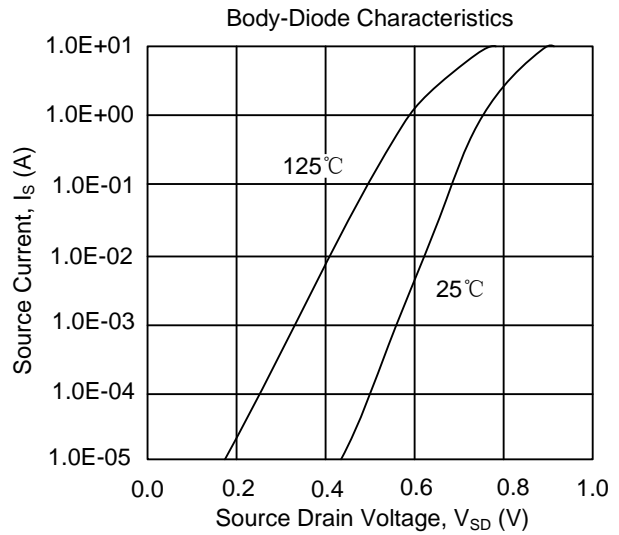
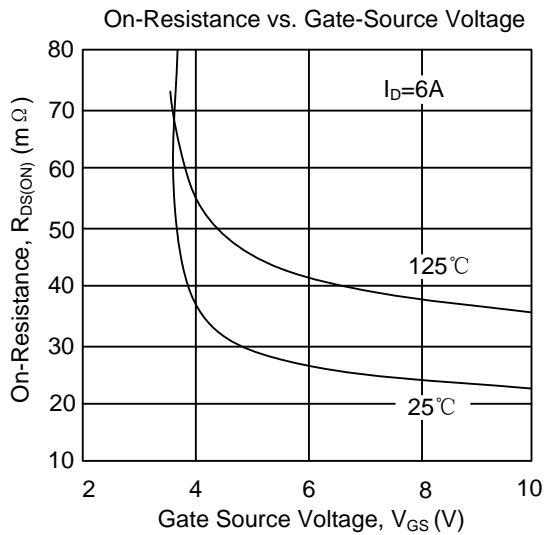
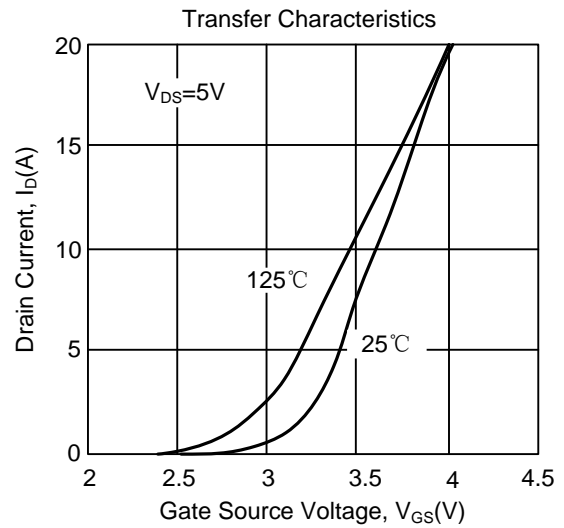
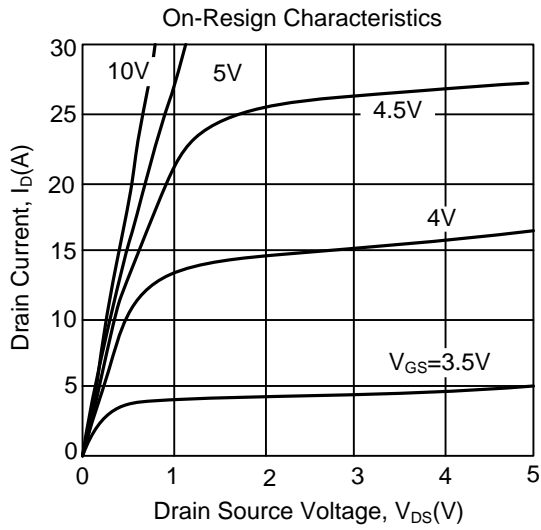

■ TYPICAL CHARACTERISTICS (Cont.)

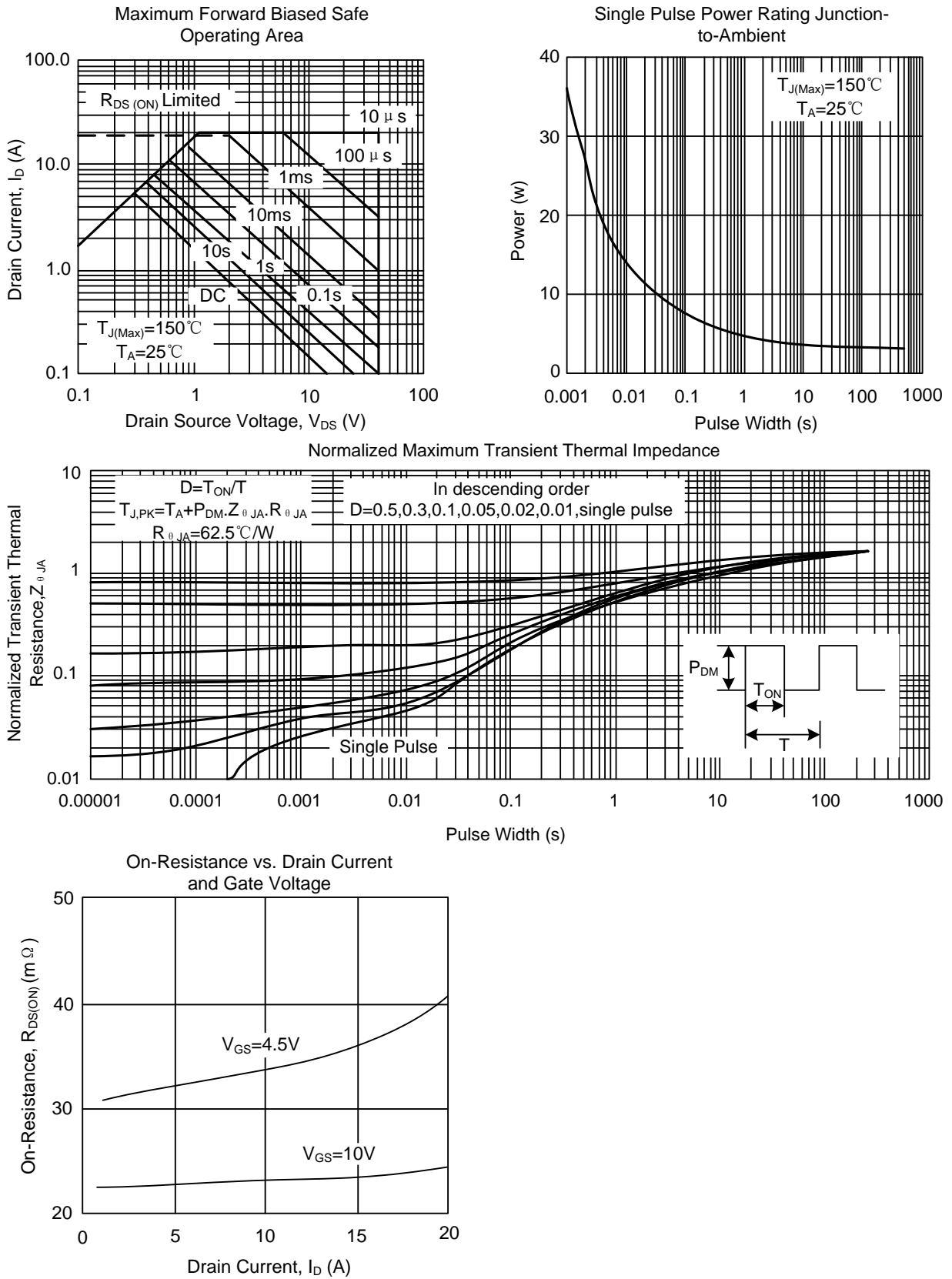

■ TYPICAL CHARACTERISTICS (Cont.)

P-CHANNEL

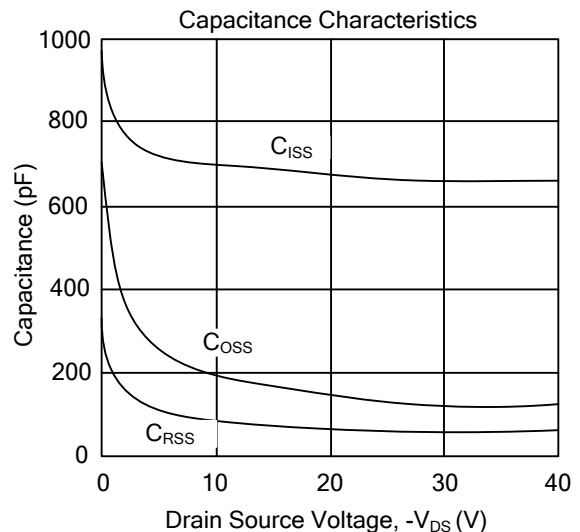
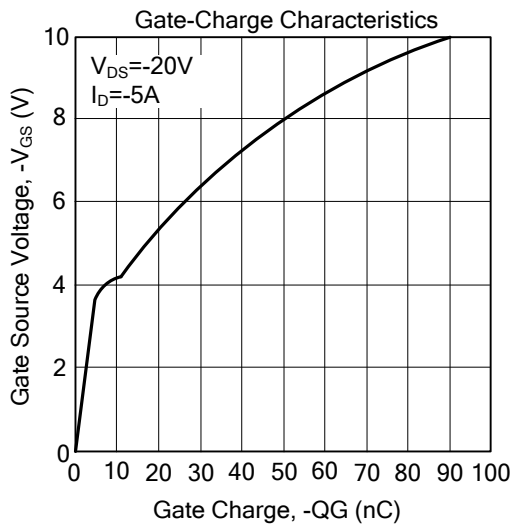
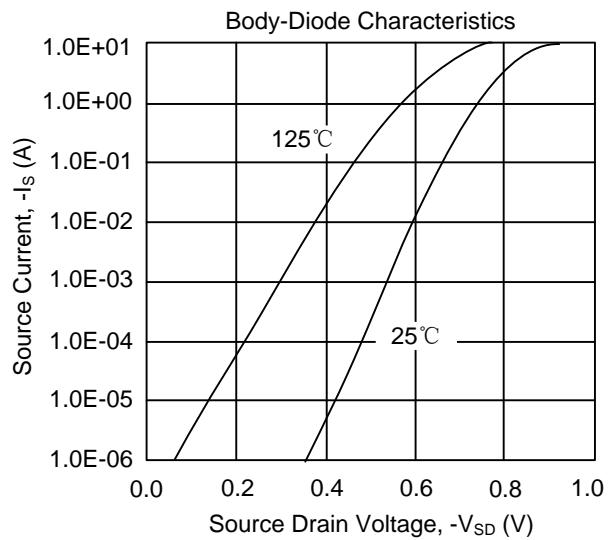
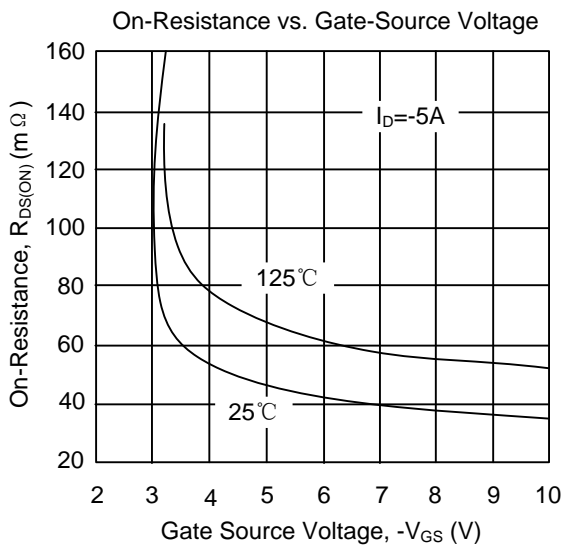
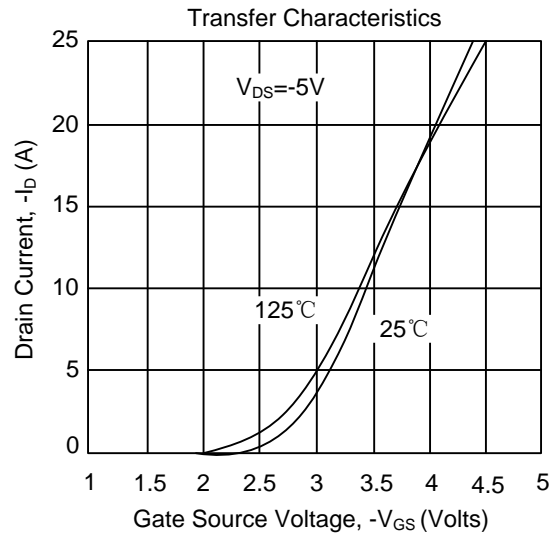
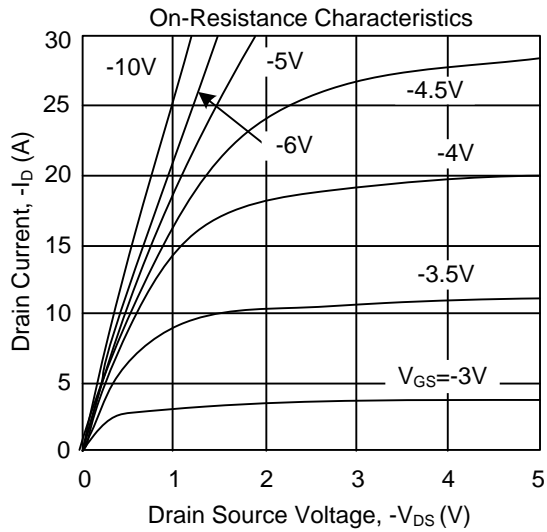

■ TYPICAL CHARACTERISTICS (Cont.)

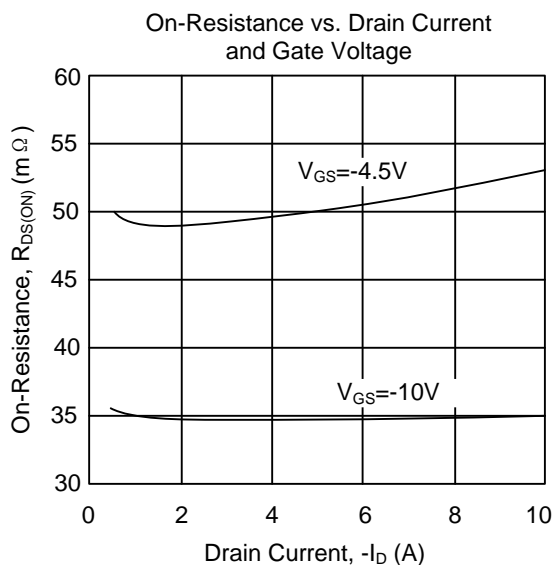
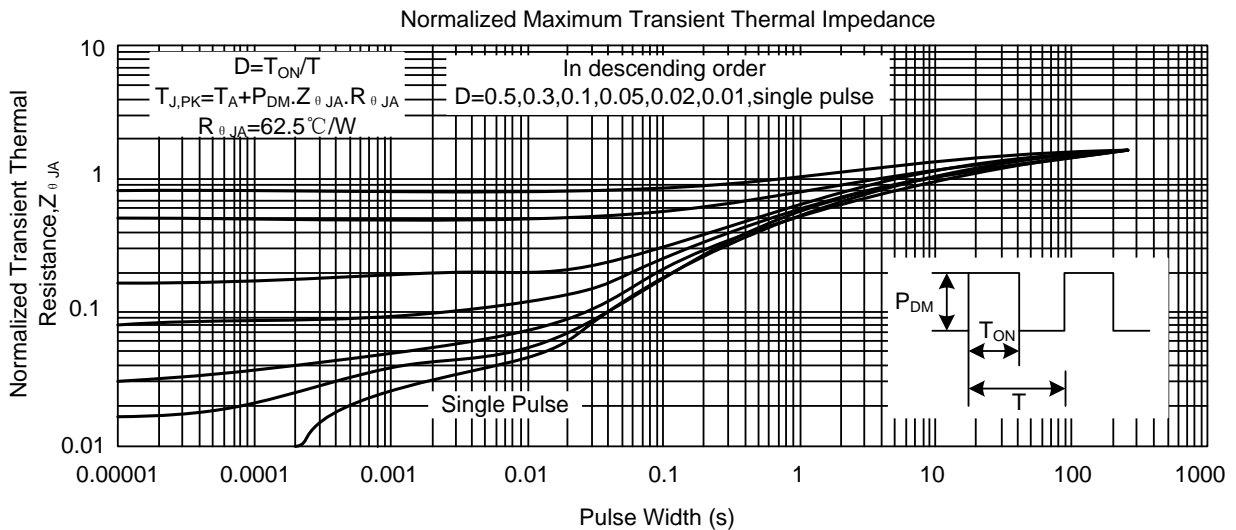
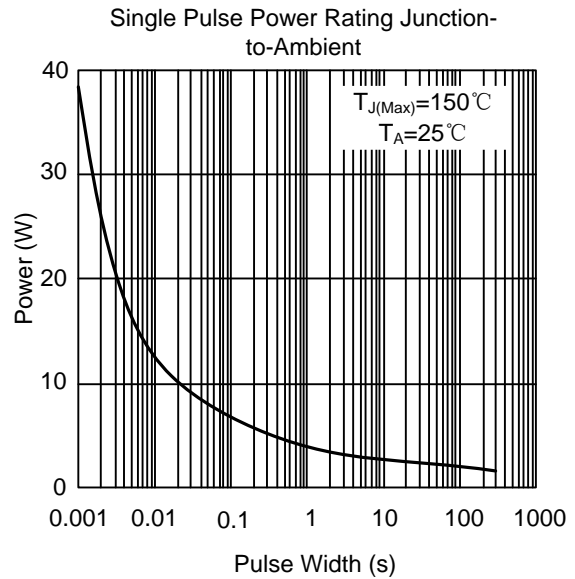
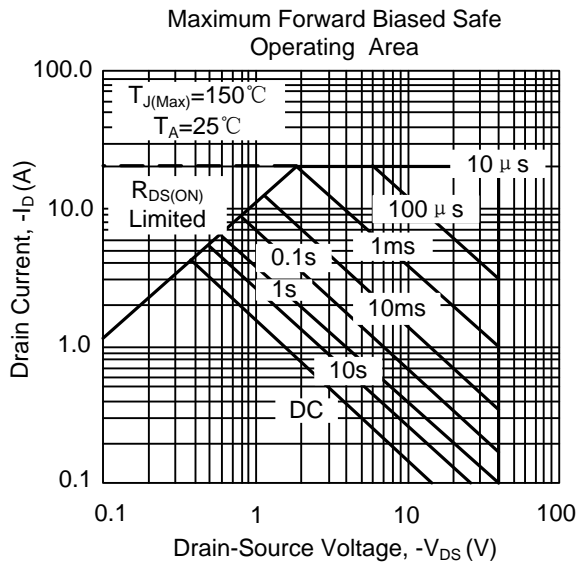

UTC assumes no responsibility for equipment failures that result from using products at values that exceed, even momentarily, rated values (such as maximum ratings, operating condition ranges, or other parameters) listed in products specifications of any and all UTC products described or contained herein. UTC products are not designed for use in life support appliances, devices or systems where malfunction of these products can be reasonably expected to result in personal injury. Reproduction in whole or in part is prohibited without the prior written consent of the copyright owner. UTC reserves the right to make changes to information published in this document, including without limitation specifications and product descriptions, at any time and without notice. This document supersedes and replaces all information supplied prior to the publication hereof.