



DATA SHEET

SEMICONDUCTOR

UF1A THRU UF1M

SURFACE MOUNT REVERSE VOLTAGE - 50 to 1000 Volts
ULTRA FAST RECTIFIERS FORWARD CURRENT - 1.0 Ampere



FEATURES

- Glass passivated chip
- Ultra fast switching for high efficiency
- For surface mounted applications
- Low forward voltage drop and high current capability
- Low reverse leakage current
- Plastic material has UL flammability classification 94V-0
- High temperature soldering : 260°C / 10 seconds at terminals
- Pb free product at available : 99% Sn above meet RoHS environment substance directive request

SMB/DO-214AA Unit:inch(mm)

MECHANICAL DATA

- Case : Molded plastic
- Polarity : Indicated by cathode band

MAXIMUM RATINGS AND ELECTRICAL CHARACTERISTICS

Ratings at 25°C ambient temperature unless otherwise specified.

Single phase, half wave, 60Hz, resistive or inductive load.

For capacitive load, derate current by 20%

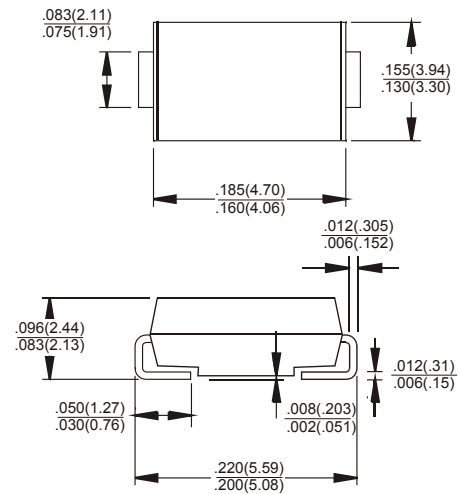

CHARACTERISTICS	SYMBOL	UF1A	UF1B	UF1D	UF1G	UF1J	UF1K	UF1M	UNIT	
Maximum Recurrent Peak Reverse Voltage	VRRM	50	100	200	400	600	800	1000	V	
Maximum RMS Voltage	VRMS	35	70	140	280	420	560	700	V	
Maximum DC Blocking Voltage	VDC	50	100	200	400	600	800	1000	V	
Maximum Average Forward Rectified Current @TL =75°C	I(AV)	1.0							A	
Peak Forward Surge Current 8.3ms single half sine-wave superimposed on rated load (JEDEC METHOD)	IFSM	30							A	
Maximum forward Voltage at 1.0A DC	VF	1.0		1.3		1.5		1.7		V
Maximum DC Reverse Current @TJ =25°C at Rated DC Blocking Voltage @TJ =100°C	IR	5							100	uA
Maximum Reverse Recovery Time (Note 1)	TRR	50				75				ns
Typical Junction Capacitance (Note 2)	CJ	20				10				pF
Typical Thermal Resistance (Note 3)	RθJL	30							°C/W	
Operating Temperature Range	TJ	-55 to +150							°C	
Storage Temperature Range	TSTG	-55 to +150							°C	

NOTES : 1.Reverse Recovery Test Conditions :IF=0.5A,IR=1.0A,IRR=0.25A.

2.Measured at 1.0MHz and applied reverse voltage of 4.0V DC.

3.Thermal Resistance junction to Lead.

RATING AND CHARACTERISTIC CURVES

UF1A THRU UF1M

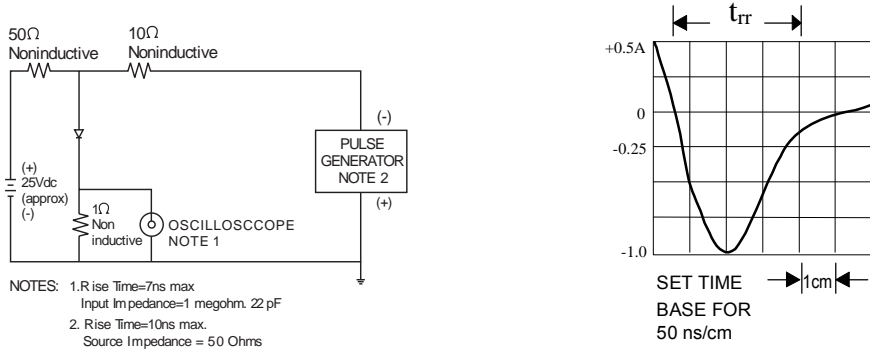

Fig. 1-REVERSE RECOVERY TIME CHARACTERISTIC AND TEST CIRCUIT DIAGRAM

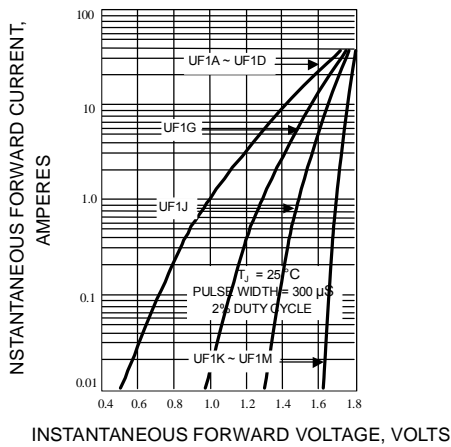

Fig. 2-FORWARD CHARACTERISTICS

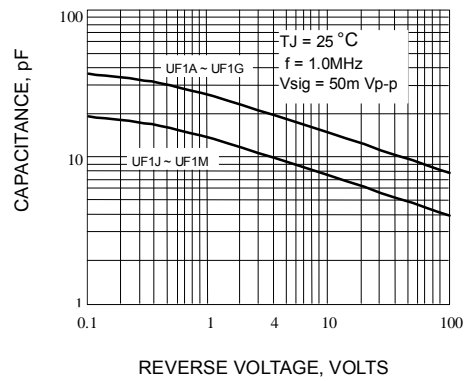

Fig. 3- TYPICAL JUNCTION CAPACITANCE

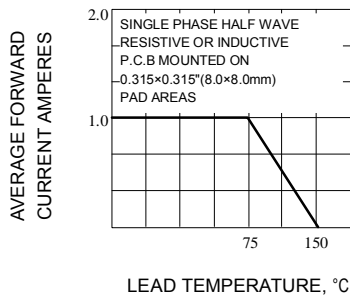

Fig. 4- FORWARD CURRENT DERATING CURVE

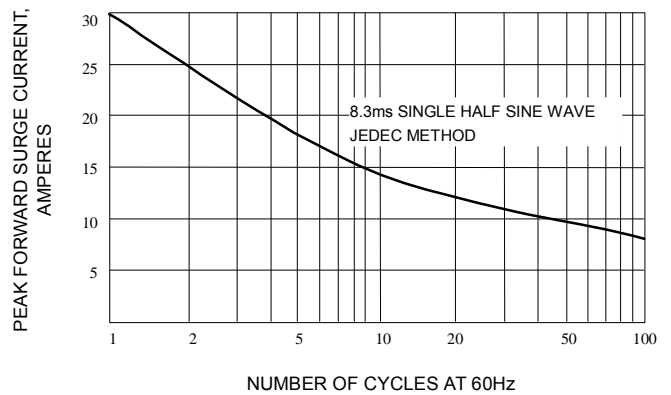

Fig. 5-PEAK FORWARD SURGE CURRENT