



UF3N25Z

Power MOSFET

3A, 250V N-CHANNEL POWER MOSFET

■ DESCRIPTION

The UTC **UF3N25Z** is an N-channel enhancement mode Power MOSFET using UTC' s advanced technology to provide customers with a minimum on-state resistance, low gate charge and superior switching performance.

■ FEATURES

- * $R_{DS(ON)} \leq 2\Omega$ @ $V_{GS}=10V, I_D=3.0A$
- * High switching speed
- * Typically 3.2nC low gate charge
- * 100% avalanche tested

■ SYMBOL

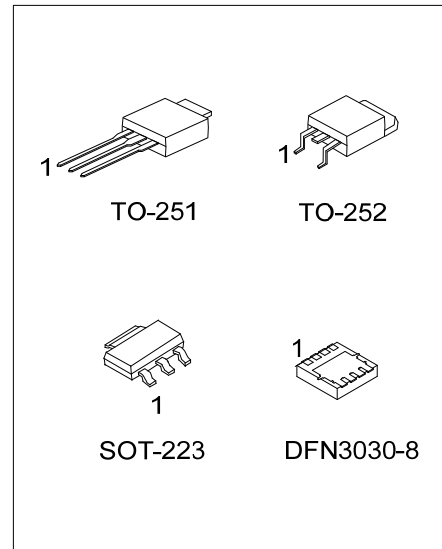
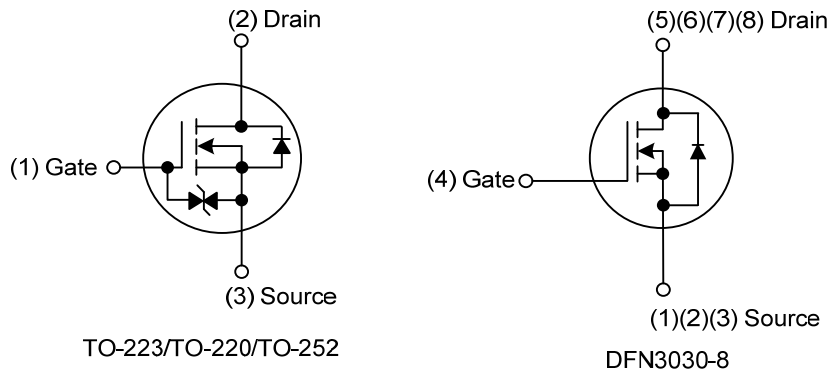

■ ORDERING INFORMATION

Ordering Number		Package	Pin Assignment								Packing
Lead Free	Halogen Free		1	2	3	4	5	6	7	8	
UF3N25ZL-AA3-R	UF3N25ZG-AA3-R	SOT-223	G	D	S	-	-	-	-	-	Tape Reel
UF3N25ZL-TM3-T	UF3N25ZG-TM3-T	TO-251	G	D	S	-	-	-	-	-	Tube
UF3N25ZL-TN3-R	UF3N25ZG-TN3-R	TO-252	G	D	S	-	-	-	-	-	Tape Reel
UF3N25ZL-K08-3030-R	UF3N25ZG-K08-3030-R	DFN3030-8	S	S	S	G	D	D	D	D	Tape Reel

Note: Pin Assignment: G: Gate D: Drain S: Source

<p>UF3N25ZG-AA3-R</p> <p>(1)Packing Type</p> <p>(2)Package Type</p> <p>(3)Green Package</p>	<p>(1) R: Tape Reel, T: Tube</p> <p>(2) AA3: SOT-223, TM3: TO-251, TN3: TO-252</p> <p>K08-3030: DFN3030-8</p> <p>(3) G: Halogen Free and Lead Free, L: Lead Free</p>
---	--

■ MARKING

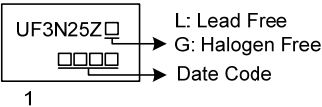
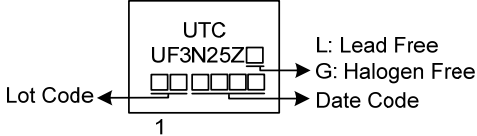
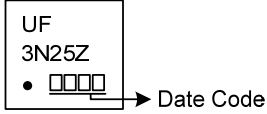
PACKAGE	MARKING
SOT-223	 <p>UF3N25Z □ □□□□</p> <p>1</p> <p>L: Lead Free G: Halogen Free Date Code</p>
TO-251 TO-252	 <p>UTC UF3N25Z □ □□□□</p> <p>Lot Code ← 1 → Date Code</p> <p>L: Lead Free G: Halogen Free</p>
DFN3030-8	 <p>UF 3N25Z • □□□□</p> <p>Date Code</p>

■ ABSOLUTE MAXIMUM RATINGS ($T_A=25^{\circ}\text{C}$, unless otherwise specified)

PARAMETER		SYMBOL	RATINGS	UNIT
Drain-Source Voltage		V_{DSS}	250	V
Gate-Source Voltage		V_{GSS}	± 20	V
Continuous Drain Current	Continuous	I_D	3	A
	Pulsed	I_{DM}	12	A
Avalanche Energy		E_{AS}	52	mJ
Power Dissipation	SOT-223	P_D	0.8	W
	TO-251/TO-252		1.14	W
	DFN3030-8		2.1 (Note 2)	W
Junction Temperature		T_J	+150	$^{\circ}\text{C}$
Storage Temperature Range		T_{STG}	-55 ~ +150	$^{\circ}\text{C}$

Notes: 1. Absolute maximum ratings are those values beyond which the device could be permanently damaged. Absolute maximum ratings are stress ratings only and functional device operation is not implied.
 2. Device mounted on FR-4 substrate P_C board, 2oz copper, with 1inch square copper plate.

■ THERMAL DATA

PARAMETER		SYMBOL	RATINGS	UNIT
Junction to Ambient	SOT-223	θ_{JA}	156	$^{\circ}\text{C/W}$
	TO-251/TO-252		110	
	DFN3030-8		60 (Note)	
Junction to Case	SOT-223	θ_{JC}	25	$^{\circ}\text{C/W}$
	TO-251		4.17	
	TO-252		4.17 (Note)	
	DFN3030-8		4.2 (Note)	

Note: Device mounted on FR-4 substrate P_C board, 2oz copper, with 1inch square copper plate.

■ ELECTRICAL CHARACTERISTICS

PARAMETER	SYMBOL	TEST CONDITIONS	MIN	TYP	MAX	UNIT
OFF CHARACTERISTICS						
Drain-Source Breakdown Voltage	BV_{DSS}	$I_D=250\mu A, V_{GS}=0V$	250			V
Drain-Source Leakage Current	I_{DSS}	$V_{DS}=250V$			10	μA
Gate-Source Leakage Current	Forward	$V_{GS}=+20V, V_{DS}=0V$			10	μA
	Reverse	$V_{GS}=-20V, V_{DS}=0V$			-10	μA
ON CHARACTERISTICS						
Gate Threshold Voltage	$V_{GS(TH)}$	$I_D=250\mu A$	2.0		4.0	V
Static Drain-Source On-State Resistance	$R_{DS(ON)}$	$V_{GS}=10V, I_D=3.0A$			2.0	Ω
DYNAMIC PARAMETERS						
Input Capacitance	C_{ISS}	$V_{GS}=0V, V_{DS}=25V, f=1MHz$		190		pF
Output Capacitance	C_{OSS}			80		pF
Reverse Transfer Capacitance	C_{RSS}			30		pF
SWITCHING PARAMETERS						
Total Gate Charge	Q_G	$V_{DD}=50V, I_D=1.3A, I_G=100\mu A, V_{GS}=10V$		3.2	5.5	nC
Gate to Source Charge	Q_{GS}			0.64		nC
Gate to Drain Charge	Q_{GD}			1.6		nC
Turn-ON Delay Time	$t_{D(ON)}$	$V_{DD}=30V, I_D=0.5A, R_G=25\Omega, V_{GS}=0\sim 10V$		30	35	ns
Rise Time	t_R			118	125	ns
Turn-OFF Delay Time	$t_{D(OFF)}$			50	58	ns
Fall-Time	t_F			90	110	ns
SOURCE- DRAIN DIODE RATINGS AND CHARACTERISTICS						
Maximum Continuous Drain-Source Diode Forward Current	I_S				3	A
Maximum Pulsed Drain-Source Diode Forward Current	I_{SM}				12	A
Drain-Source Diode Forward Voltage	V_{SD}	$I_S=3A$			1.3	V

Notes: 1. Pulse Test : Pulse width $\leq 300\mu s$, Duty cycle $\leq 2\%$.
 2. Essentially independent of operating temperature.

TYPICAL CHARACTERISTICS

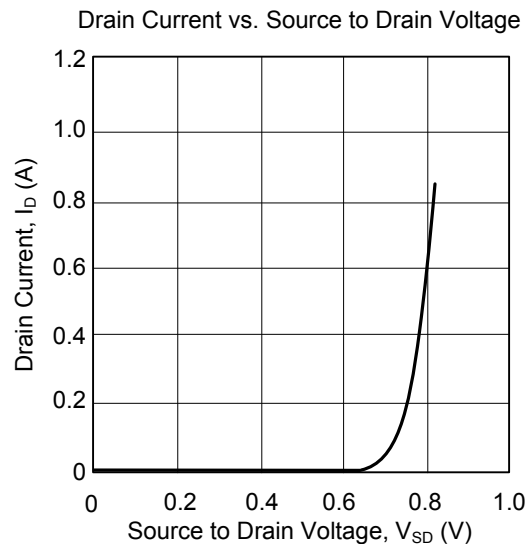
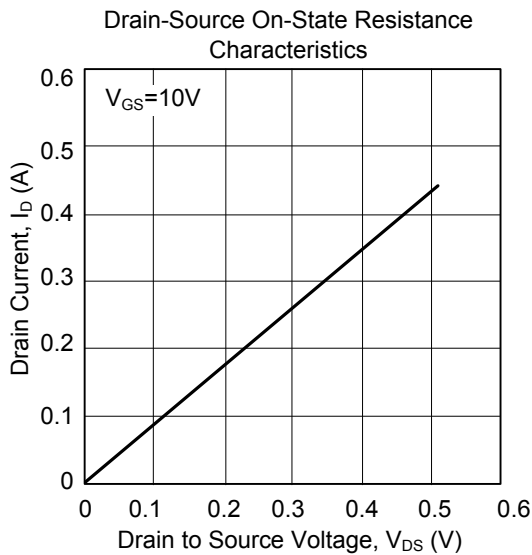
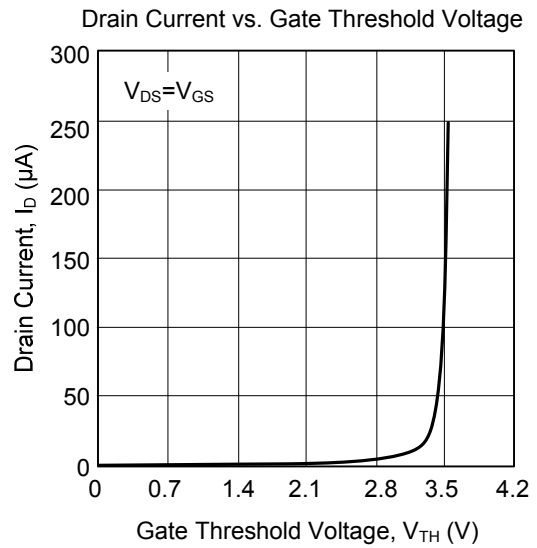
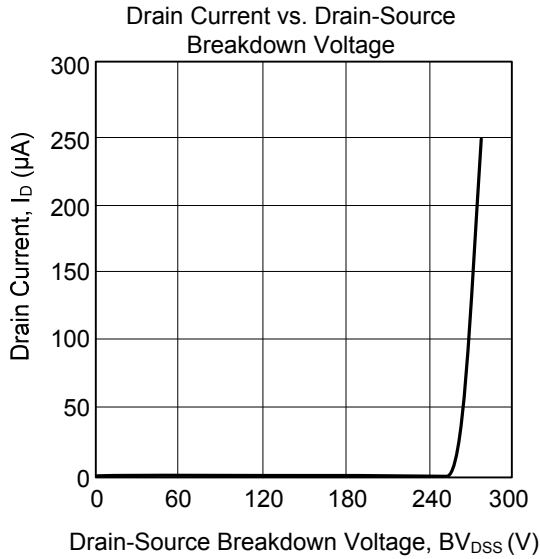

UTC assumes no responsibility for equipment failures that result from using products at values that exceed, even momentarily, rated values (such as maximum ratings, operating condition ranges, or other parameters) listed in products specifications of any and all UTC products described or contained herein. UTC products are not designed for use in life support appliances, devices or systems where malfunction of these products can be reasonably expected to result in personal injury. Reproduction in whole or in part is prohibited without the prior written consent of the copyright owner. UTC reserves the right to make changes to information published in this document, including without limitation specifications and product descriptions, at any time and without notice. This document supersedes and replaces all information supplied prior to the publication hereof.