



UF460V

Power MOSFET

21A, 500V N-CHANNEL POWER MOSFET

DESCRIPTION

The **UF460V** uses advanced UTC technology to provide excellent $R_{DS(ON)}$, low gate charge and operation with low gate voltages. This device is suitable for use as a load switch, in PWM applications, motor controls, inverters, choppers, audio amplifiers and high energy pulse circuits.

FEATURES

- * $R_{DS(ON)} = 310m\Omega @ V_{GS} = 10V, I_D = 21A$
- * Ultra low gate charge (max. 190nC)
- * Low reverse transfer capacitance ($C_{RSS} = \text{typical } 250pF$)
- * Fast switching capability
- * Avalanche energy specified
- * Improved dv/dt capability

SYMBOL

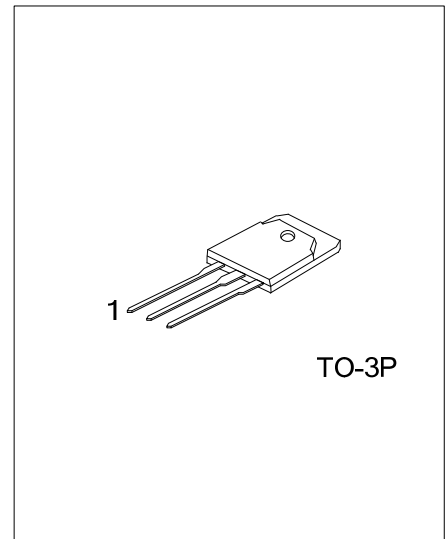
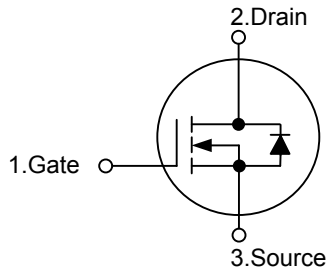

ORDERING INFORMATION

Ordering Number		Package	Pin Assignment			Packing
Lead Free	Halogen Free		1	2	3	
UF460VL-T3P-T	UF460VG-T3P-T	TO-3P	G	D	S	Tube
UF460VL-T47-T	UF460VG-T47-T	TO-247	G	D	S	Tube

<p>UF460VL-T3P-T</p> <p>(1)Packing Type</p> <p>(2)Package Type</p> <p>(3)Lead Free</p>	<p>(1) T: Tube</p> <p>(2) T3P: TO-3P</p> <p>(3) L: Lead Free, G: Halogen Free</p>
--	---

■ ABSOLUTE MAXIMUM RATINGS

PARAMETER		SYMBOL	RATINGS	UNIT
Gate-Source Voltage		V_{GS}	±20	V
Continuous Drain Current	Continuous ($V_{GS}=0V$)	I_D	21	A
Pulsed Drain Current	Pulsed (Note 2)	I_{DM}	84	A
Avalanche Current (Note2)		I_{AR}	21	A
Avalanche Energy	Repetitive(Note2)	E_{AR}	30	mJ
	Single Pulsed(Note3)	E_{AS}	1200	
Power Dissipation ($T_C=25^\circ C$)		P_D	190	W
Peak Diode Recovery dv/dt (Note4)		dv/dt	3.5	V/ns
Junction Temperature		T_J	+150	$^\circ C$
Strong Temperature		T_{STG}	-55 ~ +150	$^\circ C$

Notes: 1. Absolute maximum ratings are those values beyond which the device could be permanently damaged.

Absolute maximum ratings are stress ratings only and functional device operation is not implied.

2. Pulse width limited by $T_{J(MAX)}$

3. $V_{DD}=50V$, Starting $T_J=25^\circ C$, Peak $I_L=21A$

4. $I_{SD}\leq 21A$, $di/dt\leq 160A/\mu s$, $V_{DD}\leq 500V$, $T_J\leq 150^\circ C$, Suggested=2.35 Ω

■ THERMAL DATA

PARAMETER		SYMBOL	RATINGS	UNIT
Junction to Ambient		θ_{JA}	30	$^\circ C/W$
Junction to Case		θ_{JC}	0.42	$^\circ C/W$

■ ELECTRICAL CHARACTERISTICS ($T_J=25^\circ C$, unless otherwise specified)

PARAMETER	SYMBOL	TEST CONDITIONS	MIN	TYP	MAX	UNIT
OFF CHARACTERISTICS						
Drain-Source Breakdown Voltage	BV_{DSS}	$V_{GS}=0V, I_D=250\mu A$	500			V
Drain-Source Leakage Current	I_{DSS}	$V_{DS}=400V, V_{GS}=0V$			25	μA
Gate-Source Leakage Current	I_{GSS}	$V_{DS}=0V, V_{GS}=\pm 20V$			±100	nA
Breakdown Voltage Temperature Coefficient	$\Delta BV_{DSS}/\Delta T_J$	Reference to $25^\circ C, I_D=1.0mA$		0.78		$V/^\circ C$
ON CHARACTERISTICS						
Gate Threshold Voltage	$V_{GS(TH)}$	$V_{DS}=V_{GS}, I_D=250\mu A$	1		3	V
Static Drain-Source On Resistance (Note)	$R_{DS(ON)}$	$V_{GS}=10V, I_D=14A$		210	270	m Ω
		$V_{GS}=10V, I_D=21A$			310	
DYNAMIC PARAMETERS						
Input Capacitance	C_{ISS}	$V_{DS}=25V, V_{GS}=0V, f=1.0MHz$		4300		pF
Output Capacitance	C_{OSS}			1000		
Reverse Transfer Capacitance	C_{RSS}			250		
SWITCHING PARAMETERS						
Total Gate Charge	Q_G	$V_{DS}=50V, V_{GS}=10V, I_D=1.3A$		121		nC
Gate Source Charge	Q_{GS}			15		
Gate Drain Charge	Q_{GD}			27.5		
Turn-ON Delay Time	$t_{D(ON)}$	$V_{DD}=30V, I_D=0.5A, R_G=25\Omega$		80		ns
Turn-ON Rise Time	t_R			158		
Turn-OFF Delay Time	$t_{D(OFF)}$			1570		
Turn-OFF Fall-Time	t_F			386		
SOURCE- DRAIN DIODE RATINGS AND CHARACTERISTICS						
Drain-Source Diode Forward Voltage	V_{SD}	$I_S=21A, V_{GS}=0V, T_J=25^\circ C$			1.8	V
Maximum Continuous Drain-Source Diode Forward Current	I_S				21	A
Maximum Pulsed Drain-Source Diode Forward Current	I_{SM}				84	
Reverse Recovery Time	t_{RR}	$I_F=21A, di/dt=100A/\mu s, T_J=25^\circ C, V_{DD}\leq 50V$ (Note)			580	ns
Reverse Recovery Charge	Q_{RR}				8.1	μC

Note: Pulse Test: Pulse width $\leq 300\mu s$, Duty cycle $\leq 2\%$

TEST CIRCUITS AND WAVEFORMS

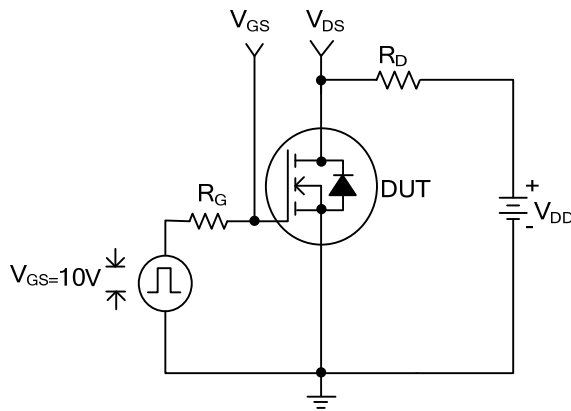

Switching Time Test Circuit

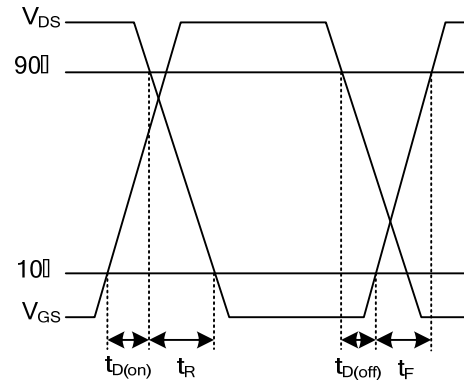

Switching Time Waveforms

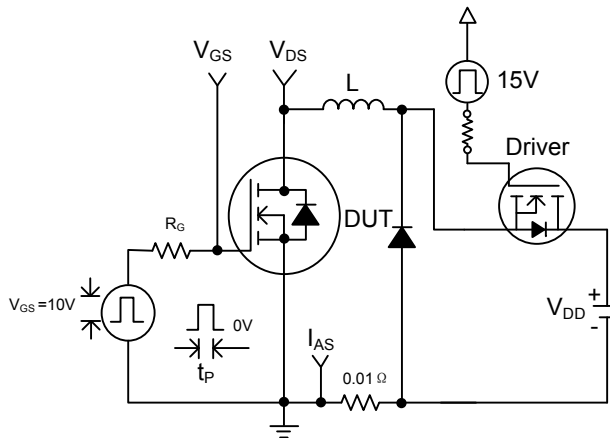

Unclamped Inductive Test Circuit

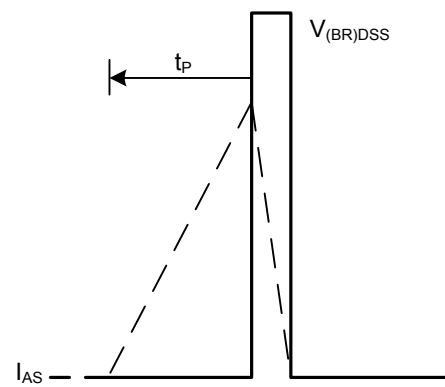

Unclamped Inductive Waveforms

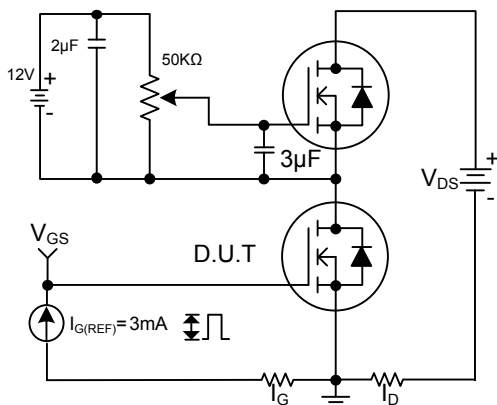

Gate Charge Test Circuit

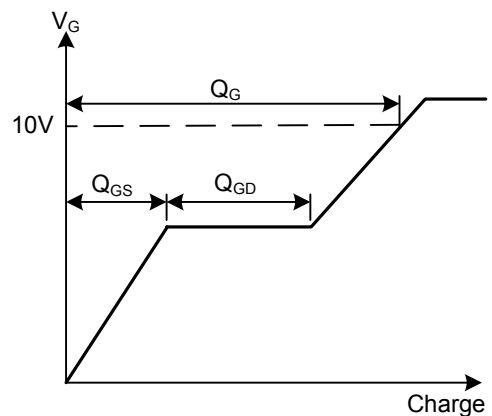

Basic Gate Charge Waveform

TYPICAL CHARACTERISTICS

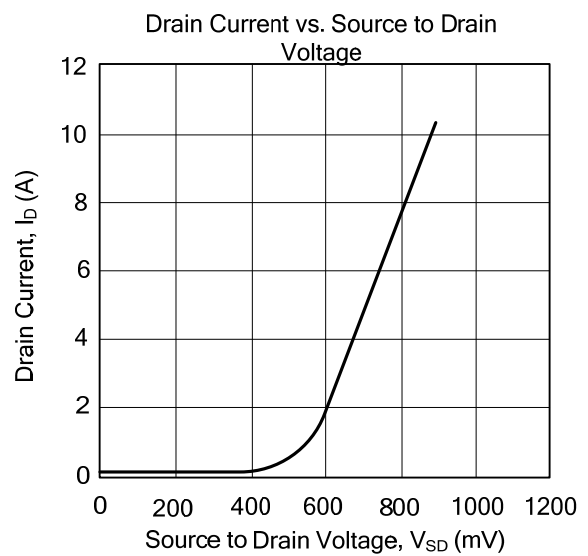
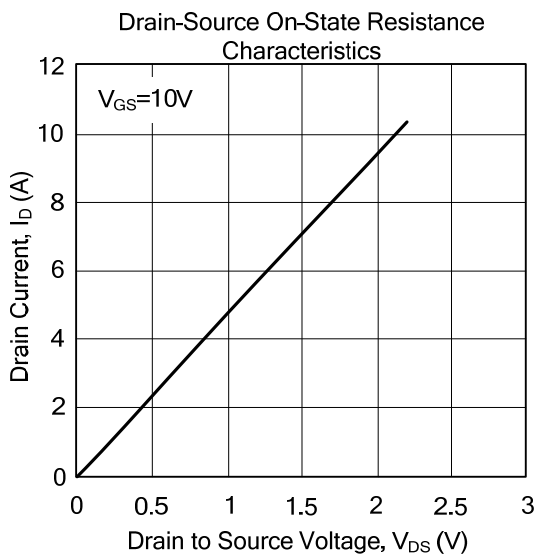
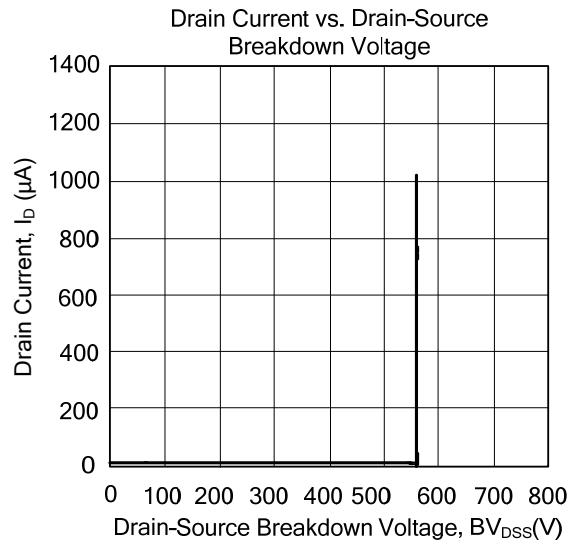
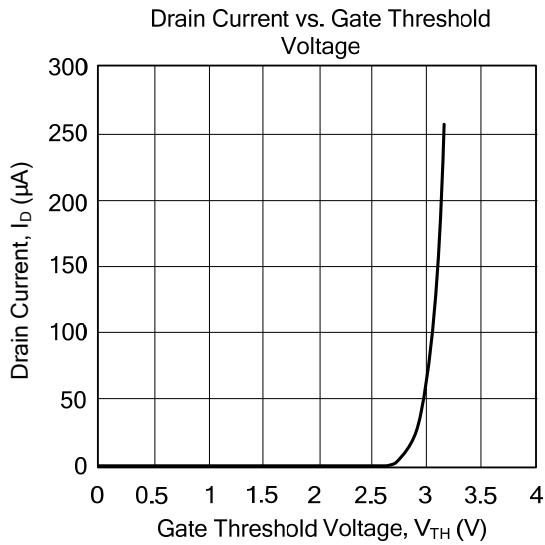

UTC assumes no responsibility for equipment failures that result from using products at values that exceed, even momentarily, rated values (such as maximum ratings, operating condition ranges, or other parameters) listed in products specifications of any and all UTC products described or contained herein. UTC products are not designed for use in life support appliances, devices or systems where malfunction of these products can be reasonably expected to result in personal injury. Reproduction in whole or in part is prohibited without the prior written consent of the copyright owner. The information presented in this document does not form part of any quotation or contract, is believed to be accurate and reliable and may be changed without notice.