

Features

- ✧ High efficiency, low VF
- ✧ High current capability
- ✧ High reliability
- ✧ High surge current capability
- ✧ Low power loss
- ✧ For use in low voltage, high frequency inverter, Free wheeling, and polarity protection application
- ✧ Green compound with suffix "G" on packing code & prefix "G" on datecode



Mechanical Data

- ✧ Case: TO-220AC
- ✧ Epoxy: UL 94V-0 rate flame retardant
- ✧ Terminals: Pure tin plated, lead free, solderable per MIL-STD-202, Method 208 guaranteed
- ✧ Polarity: As marked
- ✧ High temperature soldering: 260°C/10 seconds/ 0.16",(4.06mm) from case
- ✧ Weight: 1.8 grams

Ordering Information(example)

Part No.	Package	Packing	Packing code	Packing code (Green)
UG5J	TO-220AC	50 / TUBE	C0	C0G

Maximum Ratings and Electrical Characteristics

Rating at 25 °C ambient temperature unless otherwise specified.

Parameter	Symbol	UG5J	Unit
Maximum Repetitive Peak Reverse Voltage	V_{RRM}	600	V
Maximum RMS Voltage	V_{RMS}	420	V
Maximum DC Blocking Voltage	V_{DC}	600	V
Maximum Average Forward Rectified Current	$I_{F(AV)}$	5	A
Peak Forward Surge Current, 8.3 ms Single Half Sine-wave Superimposed on Rated Load (JEDEC method)	I_{FSM}	65	A
Maximum Instantaneous Forward Voltage (Note 1) @ 5 A / $T_A=25^{\circ}C$ @ 5 A / $T_A=125^{\circ}C$	V_F	3.0 2.5	V
Maximum DC Reverse Current at Rated DC Blocking Voltage $T_A=25^{\circ}C$ $T_A=125^{\circ}C$	I_R	30 200	uA
Maximum Reverse Recovery Time (Note 2)	T_{rr}	20	nS
Typical Thermal Resistance	$R_{\theta JC}$	3	$^{\circ}C/W$
Operating Temperature Range	T_J	- 55 to + 150	$^{\circ}C$
Storage Temperature Range	T_{STG}	- 55 to + 150	$^{\circ}C$

Note 1: Pulse Test with PW=300 usec, 1% Duty Cycle

Note 2: Reverse Recovery Test Conditions: $I_F=0.5A$, $I_R=1.0A$, $I_{RR}=0.25A$

RATINGS AND CHARACTERISTIC CURVES (UG5J)

FIG.1 FORWARD CURRENT DERATING CURVE

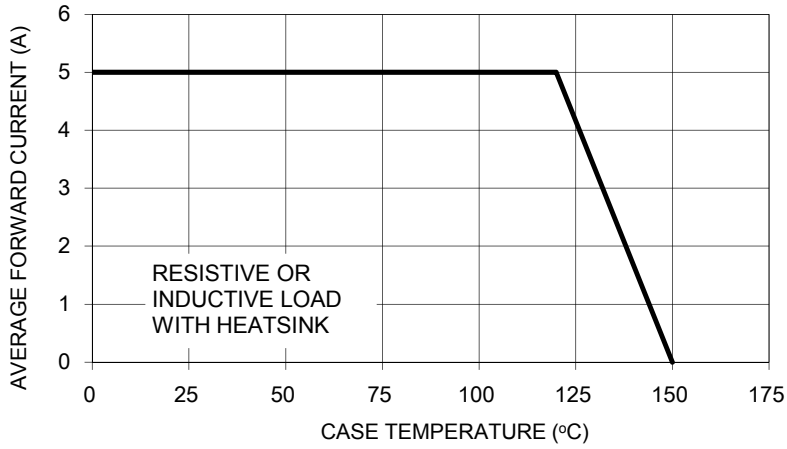

FIG. 2 TYPICAL REVERSE CHARACTERISTICS

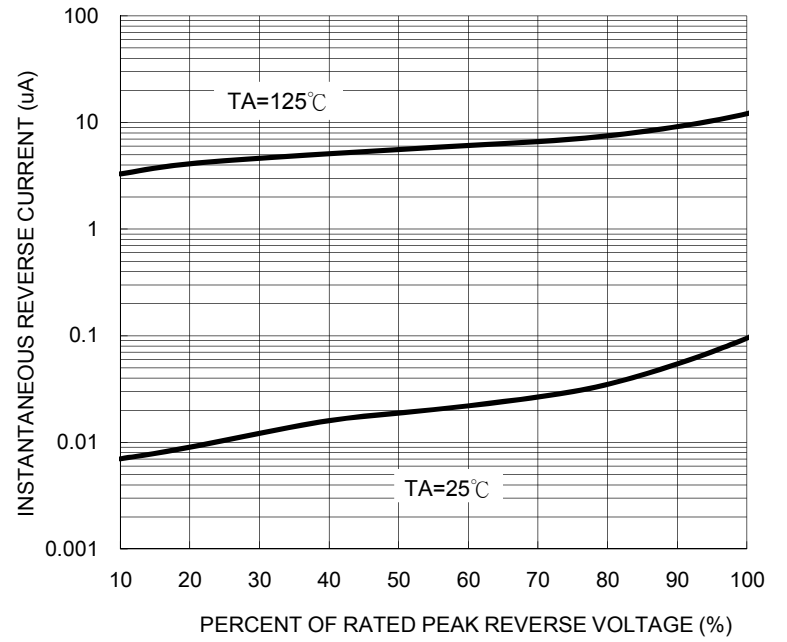

FIG. 3 MAXIMUM NON-REPETITIVE FORWARD SURGE CURRENT

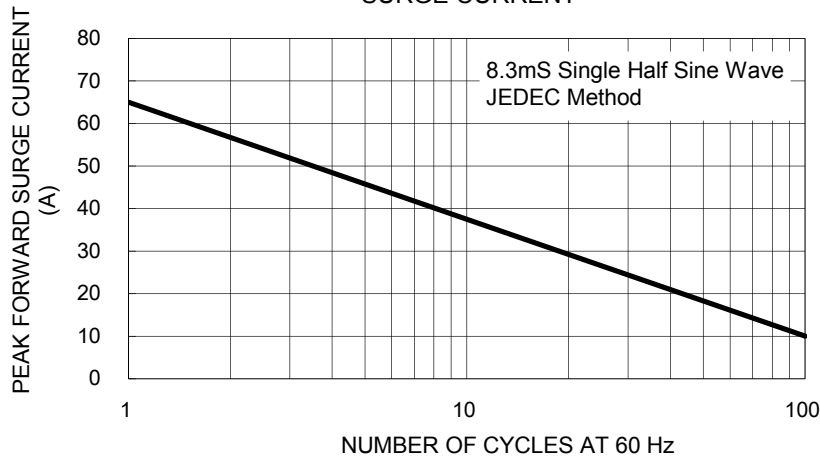

FIG. 4 TYPICAL FORWARD CHARACTERISTICS

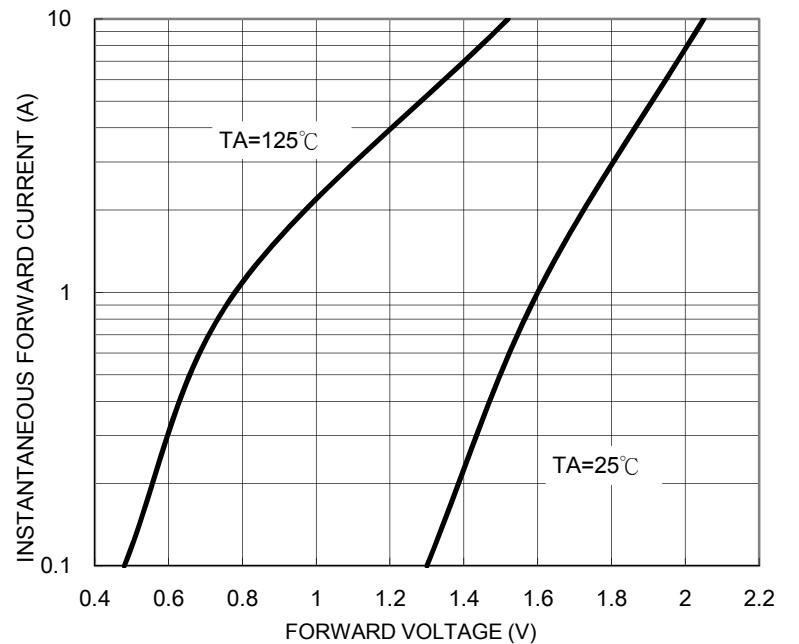

FIG. 5 TYPICAL JUNCTION CAPACITANCE

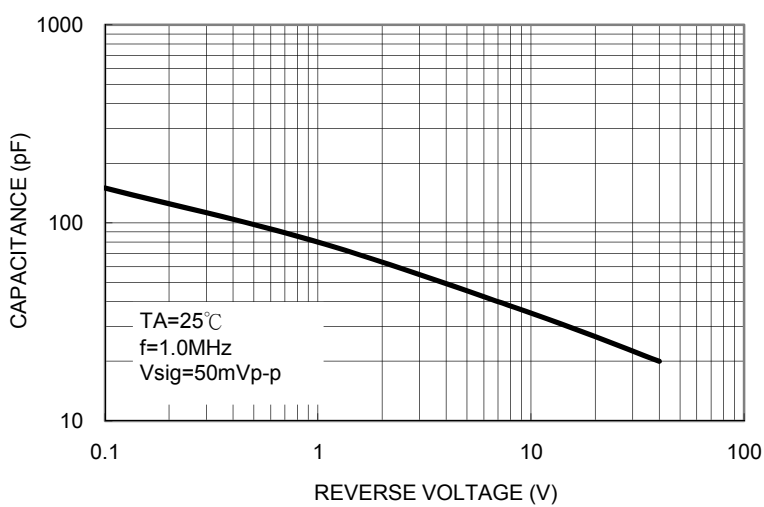
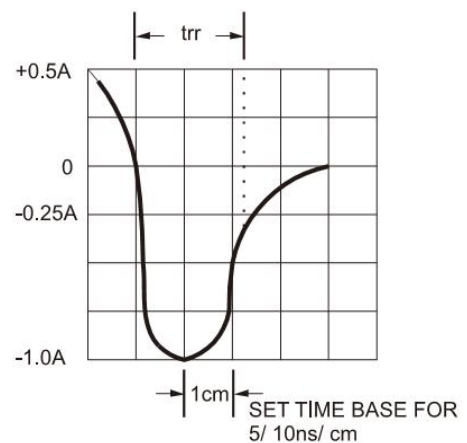
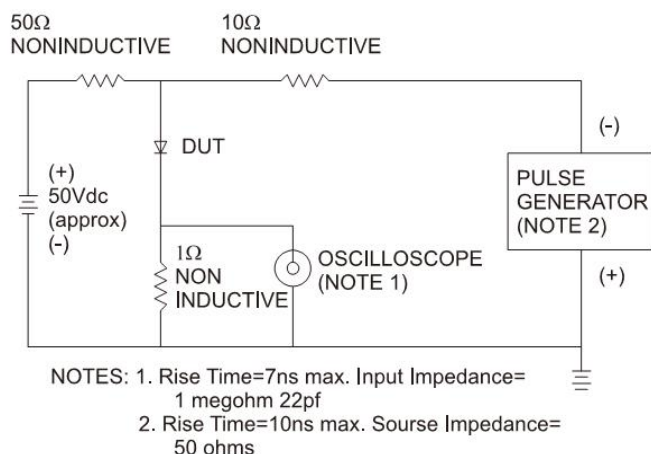
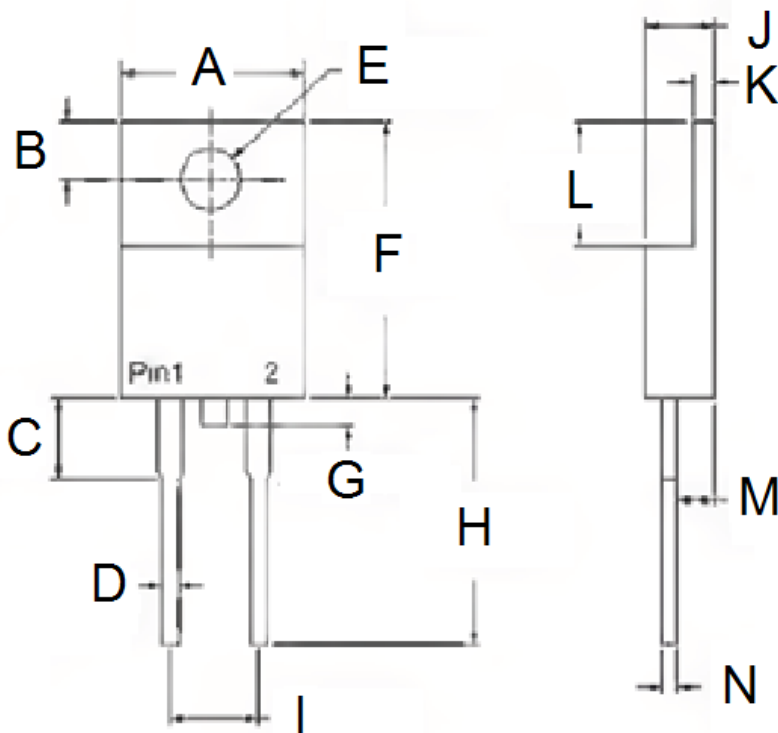

FIG.6- REVERSE RECOVERY TIME CHARACTERISTIC AND TEST CIRCUIT DIAGRAM



Ordering information

Part No.	Package	BULK Packing	Packing code	Packing code (Green)
UG5J	TO-220AC	50 / TUBE	C0	C0G

Dimensions

DIM.	Unit(mm)		Unit(inch)	
	Min	Max	Min	Max
A	-	10.50	-	0.413
B	2.62	3.44	0.103	0.135
C	2.80	4.20	0.110	0.165
D	0.68	0.94	0.027	0.037
E	3.54	4.00	0.139	0.157
F	14.60	16.00	0.575	0.630
G	-	1.60	-	0.063
H	13.19	14.79	0.519	0.582
I	4.95	5.20	0.195	0.205
J	4.42	4.76	0.174	0.187
K	1.14	1.40	0.045	0.055
L	5.84	6.86	0.230	0.270
M	2.20	2.80	0.087	0.110
N	0.35	0.64	0.014	0.025

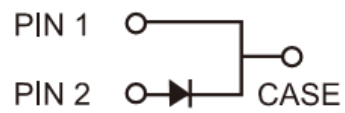
Marking Diagram

P/N = Specific Device Code
 G = Green Compound
 YWW = Date Code