



UL497

LINEAR INTEGRATED CIRCUIT

HALL EFFECT PICKUP IGNITION CONTROLLER

DESCRIPTION

As an integrated electronic ignition controller for breakerless ignition systems which uses Hall effect sensors, the UTC **UL497** drives an NPN external darlington to control the coil current providing the required stored energy with low dissipation.

One of the UTC **UL497** special features is the programmable time for the recovery of the correct dwell ratio Td/T while the coil peak current fails to reach 94 % of the nominal value.

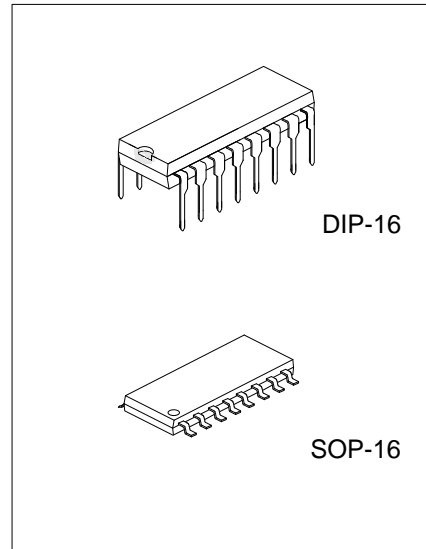

FEATURES

- * Direct driving of the external power darlington
- * Coil current charent charging angle control
- * Programme coil current peak limitation
- * When 94% nominal current not reached programmable dwell recovery time
- * RPM output
- * Has peranent conduction protection
- * Overvoltage protection
- * Internal supply zener
- * Reverse battery protection

ORDERING INFORMATION

Ordering Number		Package	Packing
Lead Free	Halogen Free		
UL497L-D16-T	UL497G-D16-T	DIP-16	Tube
UL497L-S16-R	UL497G-S16-R	SOP-16	Tape Reel

<p>UL497G-D16-T</p> <pre> --- (1)Packing Type --- (2)Package Type --- (3)Green Package </pre>	<p>(1) T: Tube, R: Tape Reel (2) D16: DIP-16, S16: SOP-16 (3) G: Halogen Free and Lead Free, L: Lead Free</p>
--	---

MARKING

DIP-16	SOP-16

■ PIN CONFIGURATION

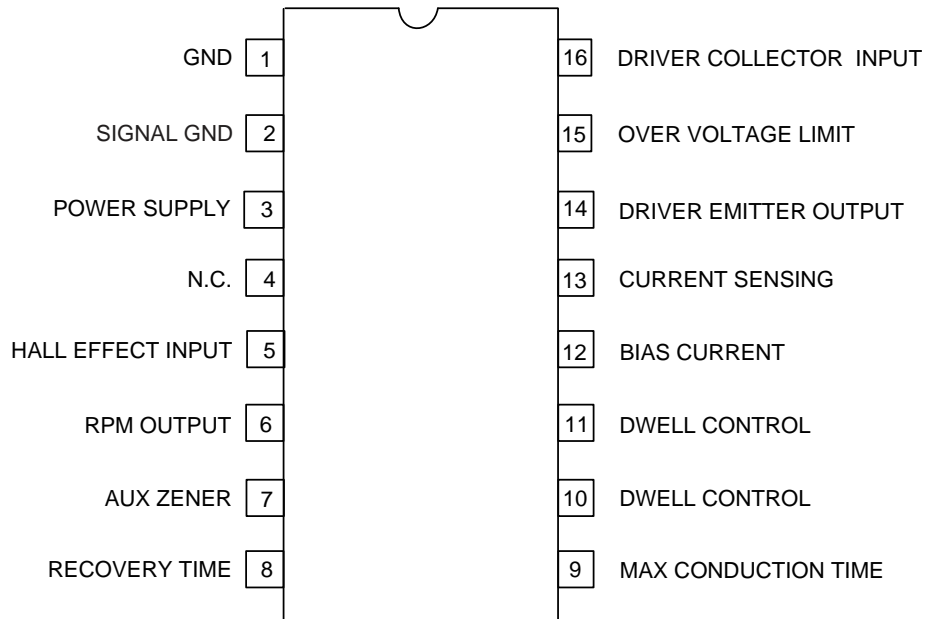

■ PIN DESCRIPTION (Refer to APPLICATION CIRCUIT)

PIN NO.	PIN NAME	DESCRIPTION
1	GND	This pin must be connected to ground.
2	SIGNAL GND	This pin must be connected to ground.
3	POWER SUPPLY	The input of supply voltage. Its voltage will be limited by an 7.5V zener. The R5 inside will limit the current by the zener for high supply voltage.
4	N.C.	Connected to ground or left open.
5	HALL-EFFECT INPUT	The input of the hall-effect pickup signal. This input is dwell control circuit output to enable the current driving into the coil.
6	RPM OUTPUT	As a open collector output, it's at low level when current flows in the ignition coil. It should be connected pin7 zener for high volteges protection. Then R ₈ must limit the zener current, too, and R ₁ limits pin 6 current if RPM module pad is accidentally connected to V _s .
7	AUX. ZENER	A 21V Zener whose current must be limited by an internal resistor.
8	RECOVERY TIME	A capacitor connected between this pin and ground sets the slope of the dwell time variation as it rises from zero to the correct value. It occurs just following the detection of $I_{coil} \leq 94\% I_{nom}$, only before the low transition of the hall-effect signal pulse. The duration is given : $t_{src} = 12.9 \times R_{7src} \times C_{src}$ (ms) PS: R ₇ (KΩ) is the biasing resistor at pin 12 and C _{src} (μF) is the delay capacitor at pin 8.
9	MAX CONDUCTION TIME	Between this pin and ground there's a capacitor which determines the intervention delay of the permanent conduction protection. The coil current is slowly reduced to zero after the delay time. Delay Time T _P is given by : $t_P = 16 \times R_7 \times C_P$ (ms) PS: R ₇ (KΩ) is the biasing resistor at pin 12 and C _P (μF) is the delay capacitor at pin 9.
10	DWELL CONTROL TIMER	Connected between this pin and ground there's a capacitor C _T which is charged when the Hall effect output is High and is discharged at the High to Low transition of the Hall effect signal. When using a 62KΩ resistor at pin12 C _T should be 100nF.
11	DWELL CONTROL	The average voltage on the capacitor CW connected between this pin and ground depends on the motor speed and the voltage supply. The comparison between V _{CW} and V _{CT} voltage determines the timing for the dwell control.
12	BIAS CURRENT	The internal current which used to drive the external capacitors of the dwell control(pin10 and11)permanent conduction protection (pin 9) and slow recovery time (pin 8) can be set by a resistor(recommended 62KΩ) connected between this pin and ground.
13	CURRENT SENSING	Connection for the Coil Current Limitation. The current limitation value is given by : $I_{sens} = 0.32 \times (R_{10} + R_{11}) \div (R_s \times R_{11})$ RS: sensing resistor
14	DRIVER EMITTER OUTPUT	Current Driver for the External Darlington.
15	OVER VOLTAGE LIMIT	The internal divider R ₃ /R ₂ defines the limitation value given by: $V_{OVP} = (22.5/R_3 + 5 \times 10^{-3}) \times R_2 + 22.5$
16	DRIVER COLLECTOR INPUT	Through this pin The collector current of the internal driver which drives the external limits darlington is supplied. Then the external resistor R ₆ the maximum current supplied to the base of the external darlington.

■ BLOCK DIAGRAM

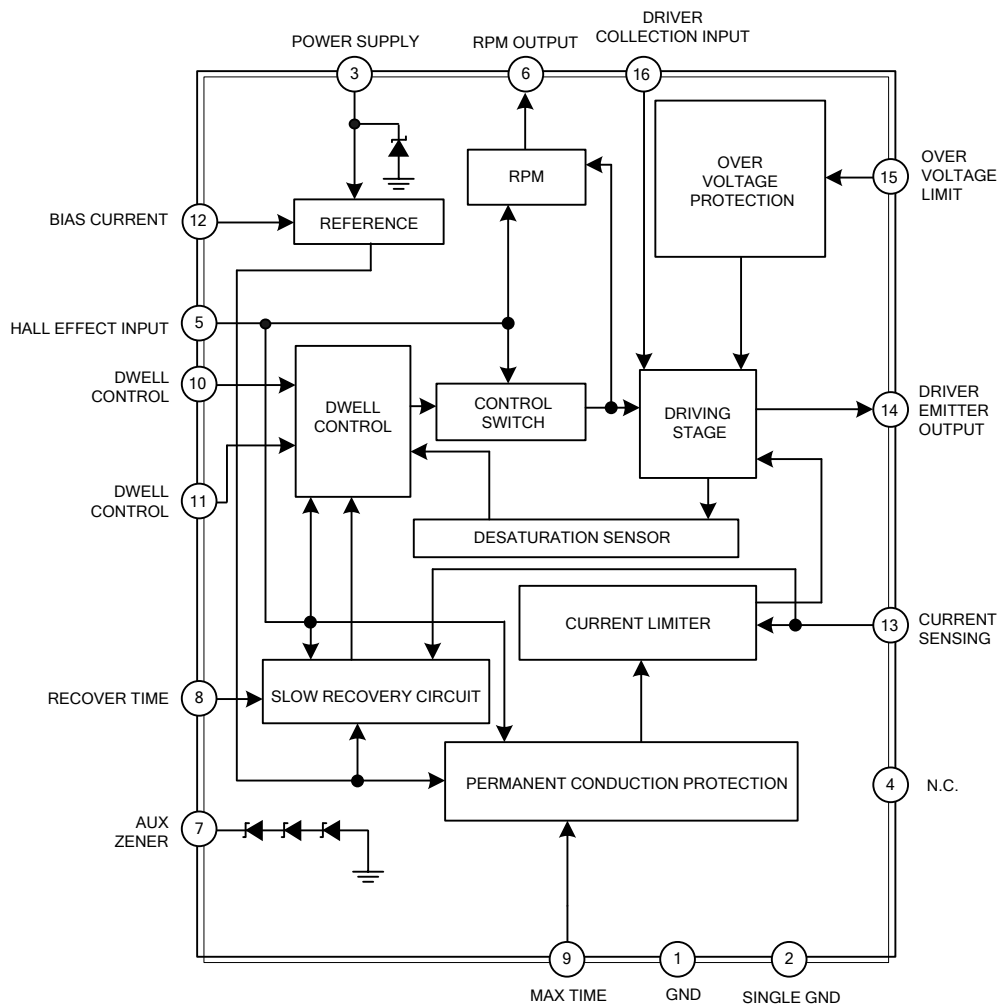

■ ABSOLUTE MAXIMUM RATING

PARAMETER		SYMBOL	RATINGS	UNIT
D.C. Supply Current		I ₃	200	mA
Transient Supply Current	t _f fall time constant=100ms		800	mA
Supply Voltage		V ₃	Internal Limited to V _{Z3}	
RPM Voltage		V ₆	28	V
D.C. Driver Collector Current		I ₁₆	300	mA
Driver Collector Voltage		V ₁₆	28	V
Auxiliary Zener Current		I ₇	40	mA
D.C. Overvoltage Zener Current	Pulse t _{fall} =300μs	I ₁₅	15	mA
	t _{rep} Repetition Time≥3ms		35	mA
Reverse Battery Voltage if Application Circuit		V _R	-16	V
Junction Temperature		T _J	-55~ +150	°C
Storage Temperature		T _{STG}	-55~ +150	°C

Note: Absolute maximum ratings are those values beyond which the device could be permanently damaged. Absolute maximum ratings are stress ratings only and functional device operation is not implied.

■ THERMAL DATA

PARAMETER		SYMBOL	RATINGS	UNIT
Junction to Ambient	DIP-16	θ _{JA}	90	°C/W
	SOP-16		55 (Note)	°C/W

Note: Thermal resistance junction Ambient with the device soldered on the middle of an Ambient supporting substrate measuring 15x20; 0.65mm thickness.

■ **ELECTRICAL CHARACTERISTICS** ($V_S=14.4V$, $-40\text{ }^\circ\text{C}<T_J<125\text{ }^\circ\text{C}$, unless otherwise specified)

PARAMETER	SYMBOL	TEST CONDITIONS	MIN	TYP	MAX	UNIT
Min Operating Voltage	V_3		3.5			V
Supply Current	I_3	$V_3=6V$	5	18	25	mA
		$V_3=4V$	5		13	mA
Voltage Supply	V_S				28	V
Supply Clamping Zener Voltage	V_{Z3}	$I_{Z3}=70\text{mA}$	6.8	7.5	8.2	V
Input Voltage	V_5	Low Status			0.6	V
		High Status	2.5			V
Input Current	I_5	$V_5=\text{LOW}$	-400		-50	μA
Darlington Driver Saturation Current	V_{16-14}	$I_{14}=50\text{mA}$			0.5	V
		$I_{14}=180\text{mA}$			0.9	V
Current Limit Sensing Voltage	V_{SENSE}	$V_S=6\sim 16V$	260	330	400	mV
C_W Charge Current	I_{11C}	$V_S=5.3\sim 16V, V_{11}=0.5V, T=10\sim 33\text{ms}$	-11.0	-9.3	-7.8	μA
C_W Charge Current	I_{11D}	$V_S=5.3\sim 16V, V_{11}=0.5V, T=10\sim 33\text{ms}$	0.5	0.7	1.0	μA
C_W Charge Discharge ratio	I_{11C}/I_{11D}	$V_S=5.3\sim 16V, V_{11}=0.5V, T=10\sim 33\text{ms}$ (Note 1)	7.8		22.0	
Percentage of Output Current Determining the Slow Recovery Control Start (Note 2)	$I_{\text{SRC}}/I_{\text{SENSE}}$		90	94	98.5	%
Duration of Altered Small Control Ratio after SRC Function Start	T_{SRC}	$C_{\text{SRC}}=1\mu\text{F}, R_7=62\text{K}\Omega$		0.8		s
External Darlington over V Prot Zener Voltage	V_{Z15}	$I_{15}=5\text{mA}$	20	25	30	V
		$I_{15}=2\text{mA}$	18	23	28	
Permanent Conduction Time	T_P	$V_5=\text{High}, C_P=1\mu\text{F}, R_7=62\text{K}\Omega$		1.0		s
RPM Output Saturation Voltage	$V_{6\text{SAT}}$	$I_6=18.5\text{mA}$			0.5	V
		$I_6=25\text{mA}$			0.8	V
RPM Output Leakage Current	$I_{6\text{LEAK}}$	$V_S=20V$			50	μA
Auxiliary Zener Voltage	V_{Z7}	$I_7=20\text{mA}$	19		27	V
Reference Voltage	V_{12}		1.0	1.2	1.3	V

Notes: 1. t_d/t desaturation ratio is given by: $t_d/T=1/[1+I_{11C}/I_{11D}]$.

2. $I_{\text{SENSE}}=I_{\text{coil}}$ when the external Darlington is in the active region.

■ APPLICATION INFORMATION

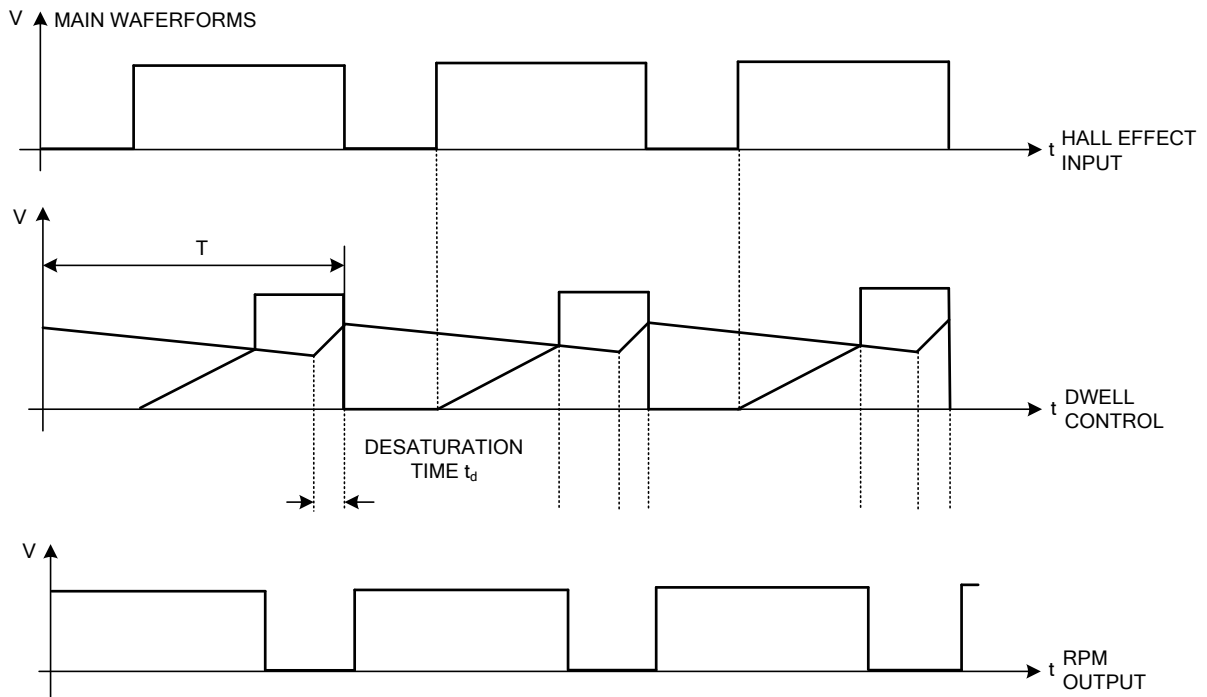

■ TYPICAL APPLICATION CIRCUIT

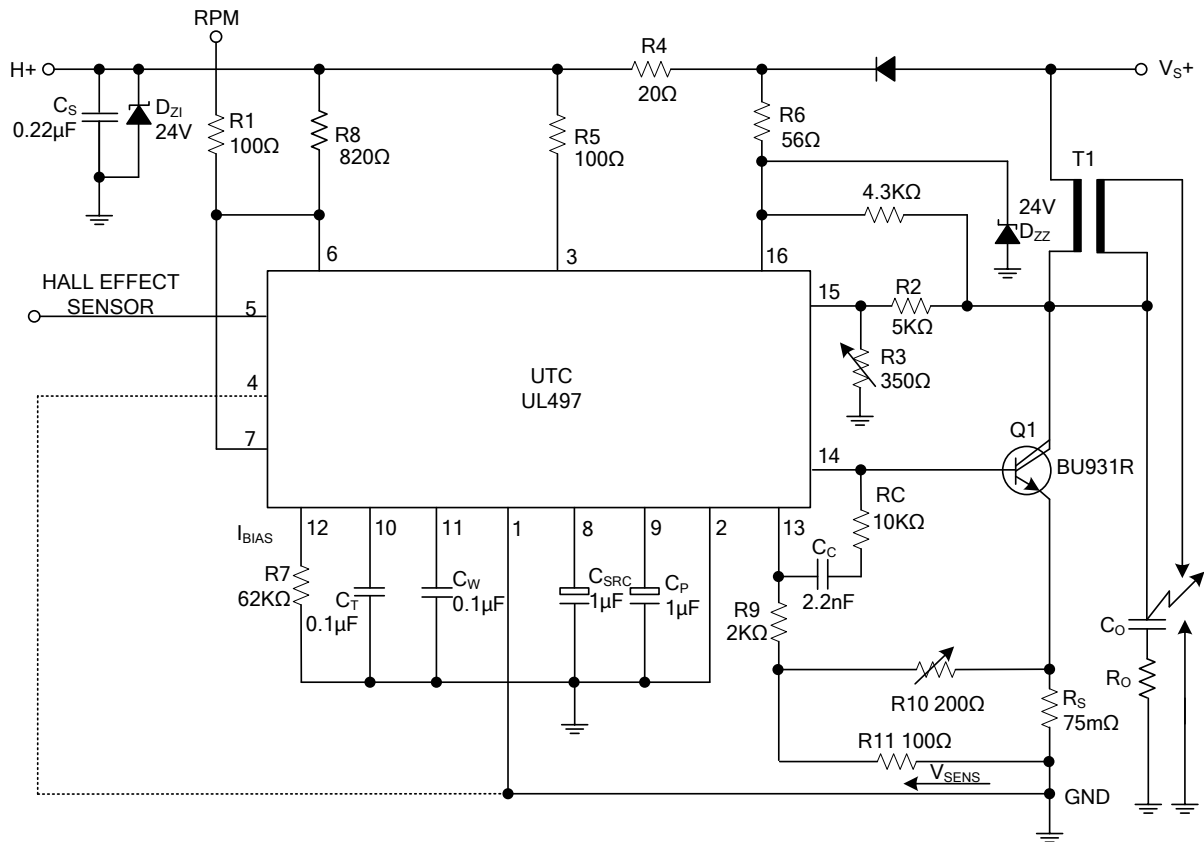

UTC assumes no responsibility for equipment failures that result from using products at values that exceed, even momentarily, rated values (such as maximum ratings, operating condition ranges, or other parameters) listed in products specifications of any and all UTC products described or contained herein. UTC products are not designed for use in life support appliances, devices or systems where malfunction of these products can be reasonably expected to result in personal injury. Reproduction in whole or in part is prohibited without the prior written consent of the copyright owner. UTC reserves the right to make changes to information published in this document, including without limitation specifications and product descriptions, at any time and without notice. This document supersedes and replaces all information supplied prior to the publication hereof.