

ULN-2429A FLUID DETECTOR

FEATURES

- High Output Current
- A-C or D-C Output
- Single-Wire Probe
- Low External Parts Count
- Internal Voltage Regulator
- Reverse Voltage Protection
- 14-Pin Dual In-Line Plastic Package

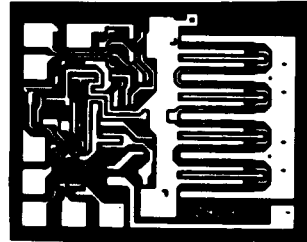

PRIMARILY DESIGNED for use as an automotive low coolant detector, the ULN-2429A monolithic bipolar integrated circuit is ideal for detecting the presence or absence of many different types of liquids in automotive, home, or industrial applications. Especially useful in harsh environments, reverse voltage protection, internal voltage regulation, temperature compensation, and high-frequency noise immunity are all incorporated in the design.

A simple probe, immersed in the fluid being monitored, is driven with an a-c signal to prevent plating problems. The presence, absence, or condition of the fluid is determined by comparing the loaded probe resistance with an internal (pin 8) or external (pin 6) resistance. Typical conductive fluids which can be sensed are tap water, sea water, weak acids and bases, wet soil, wine, beer, and coffee. Non-conductive fluids include most petroleum products, distilled water, dry soil, and vodka. The probe can be replaced with any variable-resistance element such as a photodiode or photoconductive cell, rotary or linear position sensor, or thermistor for detecting solids, non-conducting liquids, gases, etc.

The high-current output is typically a square wave signal for use with an LED, incandescent lamp, or loudspeaker. A capacitor can be connected (pin 12) to provide a d-c output for use with inductive loads such as relays and solenoids.

The ULN-2429A is rated for operation with a load voltage of up to 30 volts. Selected devices, for operation up to 50 V are available as the ULN-2429A-1. In all other respects, the ULN-2429A and the ULN-2429A-1 fluid detectors are identical.

These devices are furnished in an improved 14-lead dual in-line plastic package with a copper alloy lead frame for superior thermal characteristics. However, in order to realize the maximum current-handling capability of these devices, both of the output pins (1 and 14) and both ground pins (3 and 4) should be used.

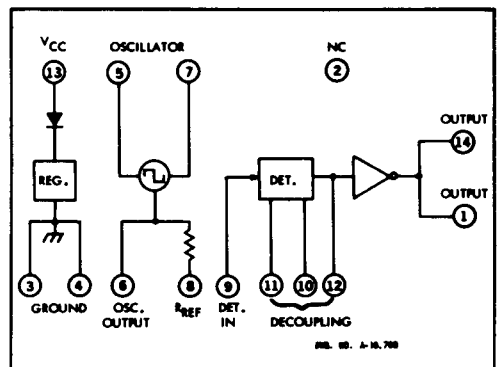

FUNCTIONAL BLOCK DIAGRAM

ABSOLUTE MAXIMUM RATINGS

- Supply Voltage, V_{CC} (continuous) +16 V, -50 V
 (1 hr. at +25°C) +24 V
 (10 μ s) +50 V
 - Output Voltage, V_{OUT} (ULN-2429A) +30 V
 (ULN-2429A-1) +50 V
 - Output Current, I_{OUT} (continuous) 700 mA
 (1 hr. at +25°C) 1.0 A
 - Package Power Dissipation, P_D 1.33 W*
 - Operating Temperature Range, T_A -40°C to +85°C
 - Storage Temperature Range, T_S -65°C to +150°C
- *Derate at the rate of 16.67 mW/°C above $T_A = +70^\circ\text{C}$.

**ELECTRICAL CHARACTERISTICS at $T_A = -25^\circ\text{C}$, $V_{CC} = V_{OUT} = +12\text{ V}$
 (unless otherwise specified)**

Characteristic	Symbol	Test Pin	Test Conditions	Limits			Units
				Min.	Typ.	Max.	
Supply Voltage Range	V_{CC}	13	—	10	—	16	V
Supply Current	I_{CC}	13	$V_{CC} = +16\text{V}$	—	—	10	mA
Oscillator Output Voltage	V_{osc}	6	$R_L = 18\text{ k}\Omega$	—	3.0	—	V_{PP}
Output ON Voltage	V_{OUT}	1,14	$R_L \geq 30\text{ k}\Omega, I_{OUT} = 500\text{ mA}$	—	0.9	1.5	V
Output OFF Current	I_{OUT}	1,14	$R_L \leq 10\text{ k}\Omega, V_{OUT} = V_{OUT(max)}$	—	—	100	μA
Oscillator Frequency	f_{osc}	6	$R_L = 18\text{ k}\Omega$	—	2.4	—	kHz

TEST CIRCUIT

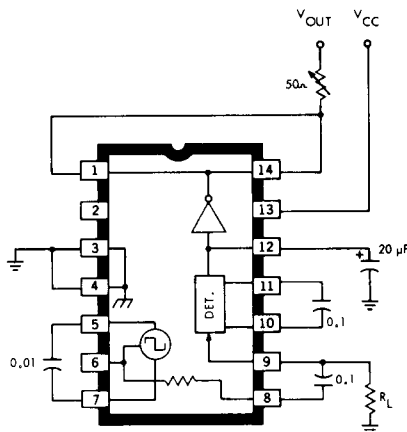

DMG. NO. A-10.707

CIRCUIT SCHEMATIC

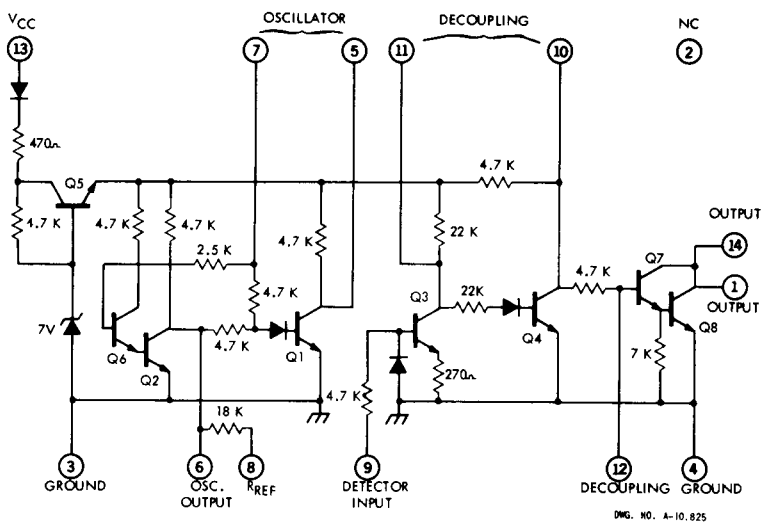

TYPICAL APPLICATIONS

