

FEATURES

- 8 Darlington Arrays per Package
- 500 mA Rated Collector Current (Single Output)
- Output voltage 50V
- Output Clamp Diodes
- Input Compatible with Various Types of Logic
- Relay-Driver Applications
- Input pins placed opposite to output pins to simplify layout

APPLICATION

- Relay Drivers
- Stepper and DC Brushed Motor Drivers
- Lamp Drivers
- Display Drivers
- Line Drivers
- Logic Buffers

DESCRIPTION

The ULN2803A is monolithic high-voltage, high-current Darlington transistor arrays. Each consists of eight NPN Darlington pairs that feature high-voltage outputs with common-cathode clamp diodes for switching inductive loads. The collector-current rating of a single Darlington pair is 500 mA. The Darlington pairs may be paralleled for higher current capability. Applications include relay drivers, hammer drivers, lamp drivers, display drivers (LED and gas discharge), line drivers, and logic buffers.

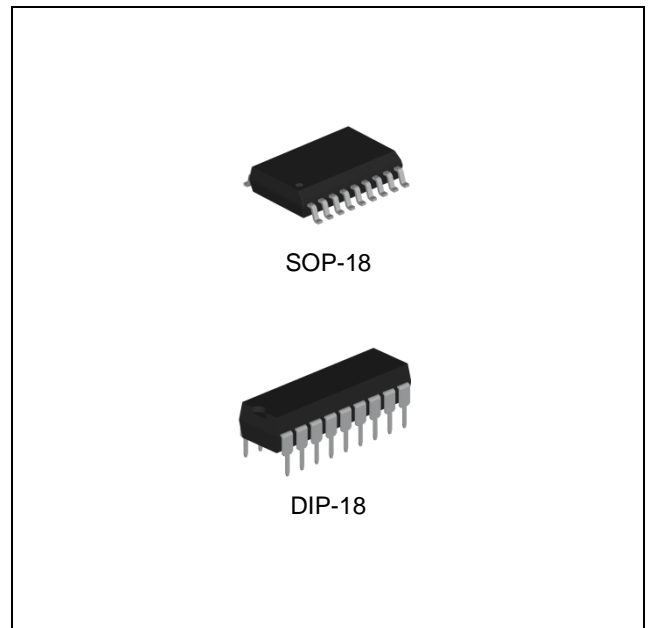

ORDERING INFORMATION

Device	Package
ULN2803AD	SOP-18
ULN2803AN	DIP-18

ABSOLUTE MAXIMUM RATINGS (Note 1)

CHARACTERISTIC	SYMBOL	MIN.	MAX.	UNIT
Output Voltage	V_O	-	50	V
Input Voltage <small>(Note 2)</small>	V_I	-	30	V
Peak Collector Current	I_C	-	500	mA
Output Clamp Current	I_{OK}	-	500	mA
Total Emitter-Terminal Current	I_E	-	2.5	A
Maximum Junction Temperature	T_J	-	150	°C

RECOMMENDED OPERATING CONDITIONS

CHARACTERISTIC	SYMBOL	MIN.	MAX.	UNIT
Output Voltage	V_O	-	50	V
Junction Temperature	T_J	-40	125	°C
Operating Free-Air Temperature Range	T_A	-40	85	°C

ORDERING INFORMATION

Package	Order No.	Description	Package Marking	Status
SOP-18	ULN2803AD	8-Digit Darlington Current Driver	ULN2803A	Active
DIP-18	ULN2803AN	8-Digit Darlington Current Driver	ULN2803A	Active

PIN CONFIGURATION

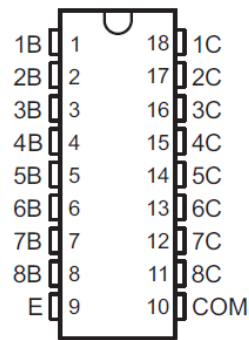

SOP-18 / DIP-18

PIN DESCRIPTION

Pin No.		Pin Name	Pin Function
SOP-18	DIP-18		
1	1	1B	Channel 1 through 8 Darlington Base Input
2	2	2B	
3	3	3B	
4	4	4B	
5	5	5B	
6	6	6B	
7	7	7B	
8	8	8B	
9	9	E	Common Emitter shared by All Channels
10	10	COM	Common Cathode Node for Flyback Diodes
11	11	8C	Channel 1 through 8 Darlington Collector Output
12	12	7C	
13	13	6C	
14	14	5C	
15	15	4C	
16	16	3C	
17	17	2C	
18	18	1C	

8-Digit Darlington Current Driver

ULN2803A

PIN CONNECTION DIAGRAM

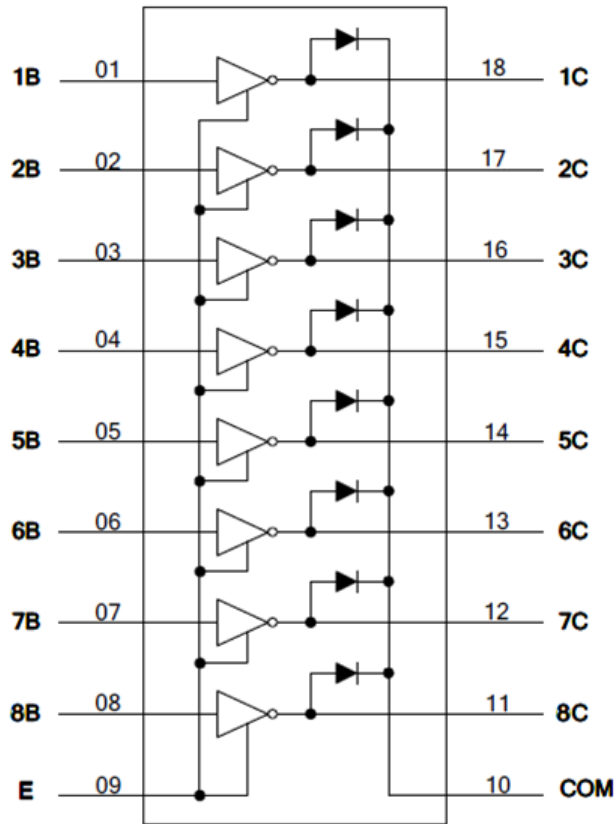

BLOCK DIAGRAM

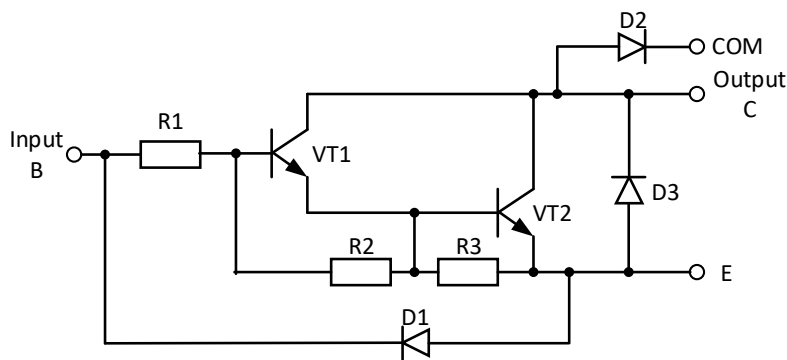

- R1 : Resistor
2.7k Ω
- R2 : Resistor
7.2 k Ω
- R3 : Resistor
3.0 k Ω

ELECTRICAL CHARACTERISTICS (Note 3)

Limits in standard typeface are for $T_J=25^\circ\text{C}$, unless otherwise specified.

PARAMETER	SYMBOL	TEST FIGURE	TEST CONDITION	MIN.	TYP.	MAX.	UNIT	
ON-State Input Voltage	$V_{I(ON)}$	Fig. 1.	$V_{CE}=2\text{V}$	$I_C=200\text{mA}$	-	-	2.4	V
				$I_C=250\text{mA}$	-	-	2.7	
				$I_C=300\text{mA}$	-	-	3.0	
Collector-Emitter Saturation Voltage	$V_{CE(SAT)}$	Fig. 2.	$I_I=250\mu\text{A}, I_C=100\text{mA}$		-	0.9	1.1	V
			$I_I=350\mu\text{A}, I_C=200\text{mA}$		-	1.0	1.3	
			$I_I=500\mu\text{A}, I_C=350\text{mA}$		-	1.2	1.6	
Output Leakage Current	I_{CEX}	Fig. 3. Fig. 4.	$V_{CE}=50\text{V},$	$I_I=0\text{mA}$	-	-	50	μA
			$V_{CE}=50\text{V},$ $T_A=85^\circ\text{C}$	$I_I=0\text{mA}$	-	-	100	
				$V_I=1\text{V}$	-	-	500	
Clamp Forward Voltage	V_F	Fig. 5.	$I_F=350\text{mA}$		-	1.7	2	V
Off-State Input Current	$I_{I(OFF)}$	Fig. 6.	$V_{CE}=50\text{V}, I_C=500\mu\text{A}, T_A=85^\circ\text{C}$		50	65	-	μA
Input Current	$I_{I(ON)}$	Fig. 7.	$V_I=3.85\text{V}$		-	-	1.35	mA
Clamp Diode Leakage Current	I_R	Fig. 8.	$V_R=50\text{V}$		-	-	50	μA
			$V_R=50\text{V}, T_A=85^\circ\text{C}$		-	-	100	
Turn-On Propagation Delay Time	t_{PLH}	-	$V_{OUT}=50\text{V}, R_L=125\Omega, C_L=15\text{pF}$		-	0.1		μs
Turn-Off Propagation Delay Time	t_{PHL}	-	$V_{OUT}=50\text{V}, R_L=125\Omega, C_L=15\text{pF}$		-	0.2		

Note 1. Stresses beyond those listed under *Absolute Maximum Ratings* may cause permanent damage to the device. These are stress ratings only, and functional operation of the device at these or any other conditions beyond those indicated under *Recommended Operating Conditions* is not implied. Exposure to absolute-maximum-rated conditions for extended periods may affect device reliability.

Note 2. All voltage values are with respect to the emitter/substrate terminal E, unless otherwise noted.

Note 3. The device is not guaranteed to function outside its operating ratings.

PARAMETER MEASUREMENT INFORMATION

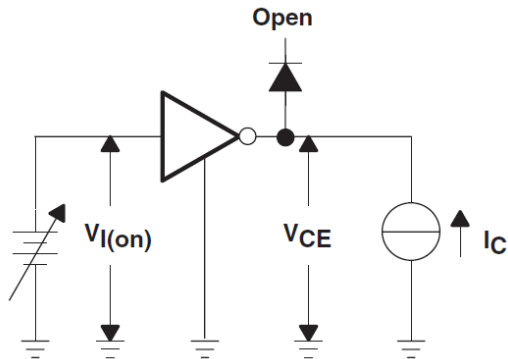

Fig. 1. ON-State Input Voltage Test Circuit

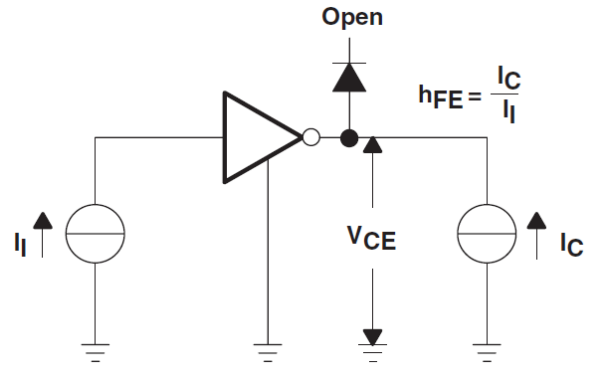

Fig. 2. Collector-Emitter Saturation Voltage Test Circuit

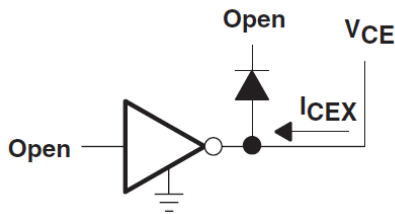

Fig. 3. Output Leakage Current Test Circuit

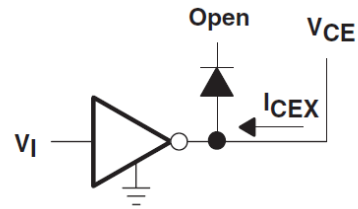

Fig. 4. Output Leakage Current Test Circuit

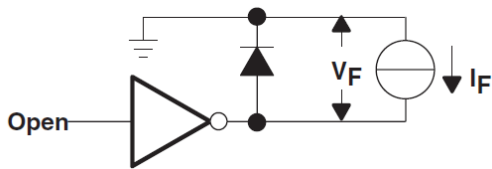

Fig. 5. Clamp Forward Voltage Test Circuit

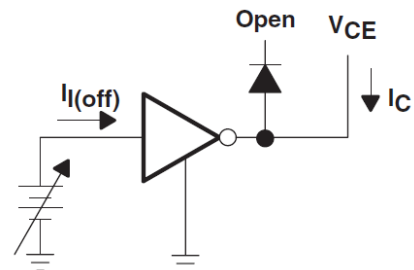

Fig. 6. Off-State Input Current Test Circuit

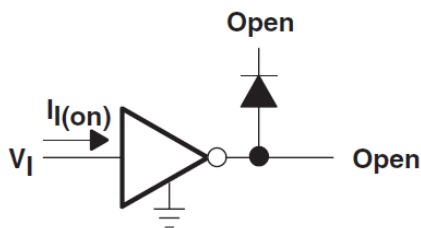

Fig. 7. Input Current Test Circuit

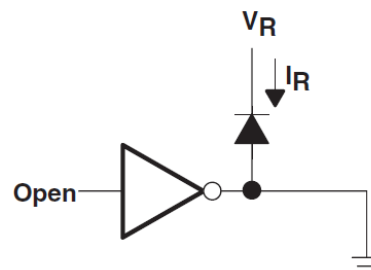

Fig. 8. Clamp Diode Leakage Current Test Circuit

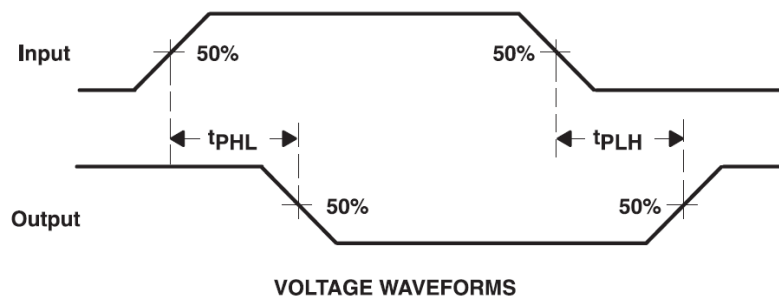

Fig. 9. Propagation Delay Time Waveform

APPLICATION INFORMATION

T.B.D.

TYPICAL OPERATING CHARACTERISTICS

T.B.D.

REVISION NOTICE

The description in this datasheet is subject to change without any notice to describe its electrical characteristics properly.