



ULS4X2

Advance

CMOS IC

4X2 SWITCH MATRIX WITH TONE/POLARITY CONTROLLER

DESCRIPTION

The UTC **ULS4X2** is a low-cost 4 x 2 switch matrix with tone detector in a 20-lead QFN package. It is used in RF multiplexing applications from 200 to 3000 MHz. There is a 4 bit decoder and tone/polarity detector integrated with RF switch which can reject DiSEqC control signals. Switch may be used in 50/75 ohm systems.

Both switch outputs (OP1 & OP2) can independently select any of the four inputs (HH, HL, VH, VL) or simultaneously select the same inputs. Note that the switch is bi-directional and input/output functionality may be interchanged.

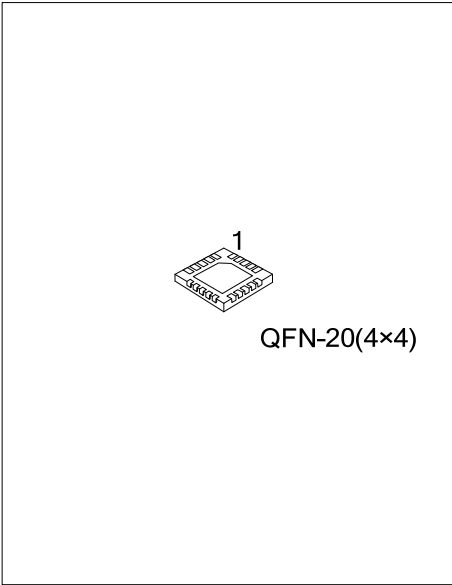

ORDERING INFORMATION

Ordering Number	Package	Packing
ULS4X2AG-Q20-4040-R	QFN-20(4x4)	Tape Reel
ULS4X2BG-Q20-4040-R	QFN-20(4x4)	Tape Reel

<p>ULS4X2XG-Q20-4040-R</p> <ul style="list-style-type: none"> (1) Packing Type (2) Package Type (3) Green Package (4) VHM Pin Code 	<ul style="list-style-type: none"> (1) R: Tape Reel (2) Q20-4040: QFN-20(4x4) (3) G: Halogen Free and Lead Free (4) Refer to TRUTH TABLE
--	--

MARKING

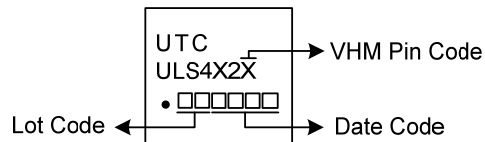

■ PIN CONFIGURATION

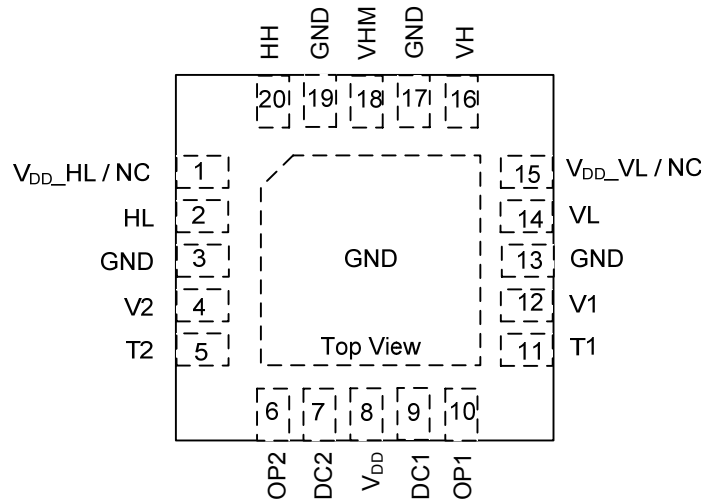

■ PIN DESCRIPTION

PIN NO.	PIN NAME	DESCRIPTION
1	V _{DD_HL} / NC	ESD V _{DD} path can be connected to pin 8 (V _{DD}), or let this pin NC
15	V _{DD_VL} / NC	ESD V _{DD} path can be connected to pin 8 (V _{DD}), or let this pin NC
3, 13, 17, 19	GND	Ground pin, connect to ground
2	HL	RF input pin
14	VH	
16	VL	
20	HH	
4	T2	Tone and polarity detector input
5	V2	
6	OP2	RF output pin
10	OP1	
7	DC2	By-pass, connect to by-pass capacitor
9	DC1	
8	V _{DD}	IC Power , connect to 3.6V power
11	T1	Tone and polarity detector input
12	V1	
18	VHM	Vertical-Horizontal mirror Connect to ground → Normal Leave open → Mirror
Back side paddle	GND	Connected to PCB GND

■ BLOCK DIAGRAM

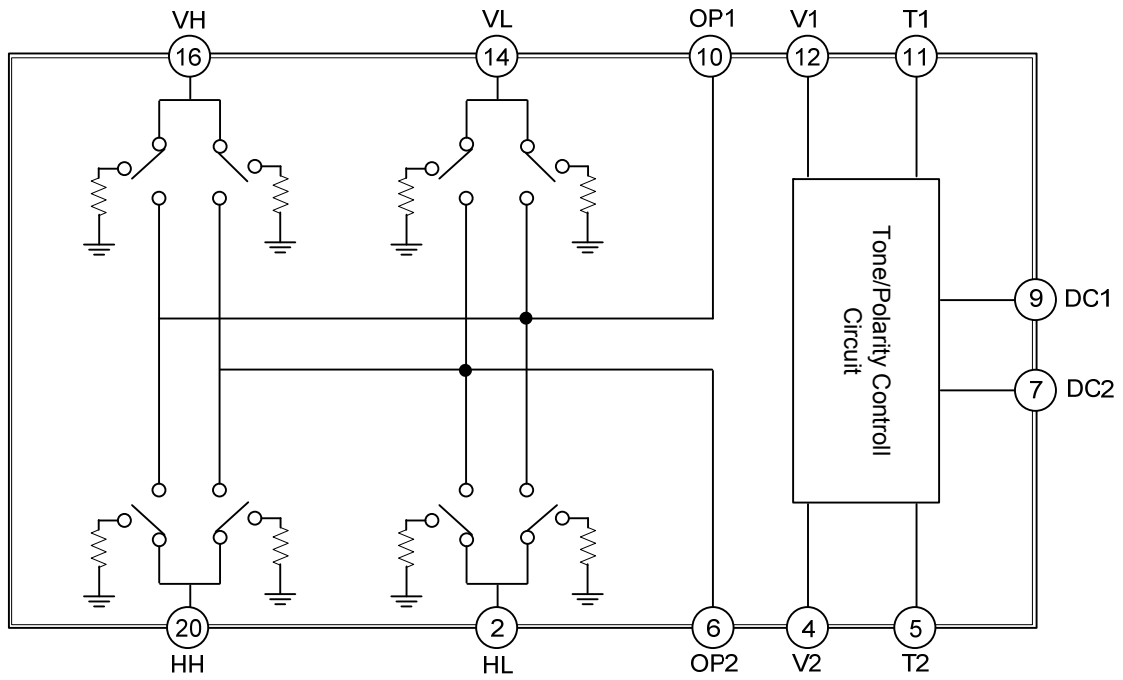

■ ABSOLUTE MAXIMUM RATING

PARAMETER	SYMBOL	RATINGS	UNIT
Bias Voltage Range	V_{DD}	+5	V
Maximum Input Power (200 ~ 3000MHz)	I_P	+17	dBm
Storage Temperature	T_{STG}	-65 ~ +150	°C
Operating Temperature	T_{OPR}	-40 ~ +85	°C

Note: Absolute maximum ratings are those values beyond which the device could be permanently damaged. Absolute maximum ratings are stress ratings only and functional device operation is not implied.

■ ELECTRICAL CHARACTERISTICS

($T_A=+25^{\circ}C$, $V_{DD}=+3.3V$, 50ohm System. All R_F port are terminated to 50 ohm)

PARAMETER	SYMBOL	TEST CONDITIONS	MIN	TYP	MAX	UNIT
Switch						
Insertion Loss	I_L	200~950MHz		6.4		dB
		950~1450MHz		6.5		
		1450~2150MHz		6.6		
		2150~3000MHz		6.8		
Isolation	I_{SO}	200~950MHz		73		dB
		950~1450MHz		64		
		1450~2150MHz		51		
		2150~3000MHz		40		
Return Loss (Input, VL, HI, VH, HH)	R_{L_IN}	200~3000MHz	14	19		dB
Return Loss (Output, OP1, OP2)	R_{L_OUT}	200~3000MHz	12	15		dB
Output IP3	O_{IP3}	200~3000MHz	20.8			dBm
Input Power for 1 dB Compression	IP_{1db}	200~3000MHz	14.5			dBm
Switching On/Off Speed t_{RISE}/t_{FALL} (10/90% RF)	T_{sw}	200~3000MHz			10	ms
Polarity and Tone Detector						
Polarity Threshold	V_{PTH}	With external 76k Ω	14.1	14.8	15.6	V
Tone Signal Frequency	F_{tone}	-40~85°C, 650m V_{PP}	1	22	2200	KHz
Tone Signal Duty Cycle	DU	-40~85°C	20	50	80	%
Tone Signal Amplitude Threshold	V_{TTH}	With external 76k Ω and 500pF	0.04	0.16		V_{PP}
Power Supply						
Supply Voltage	V_{DD}	-40~85°C	3.0	3.3	4.2	V
Current Consumption	I_{DD}	-40~85°C	1.5	2.0	2.5	mA

Note: Tone/Polarization threshold could be tuned by change the value of external R, C. Please Contact AMICCOM FAE for specified application.

■ TYPICAL APPLICATION CIRCUIT

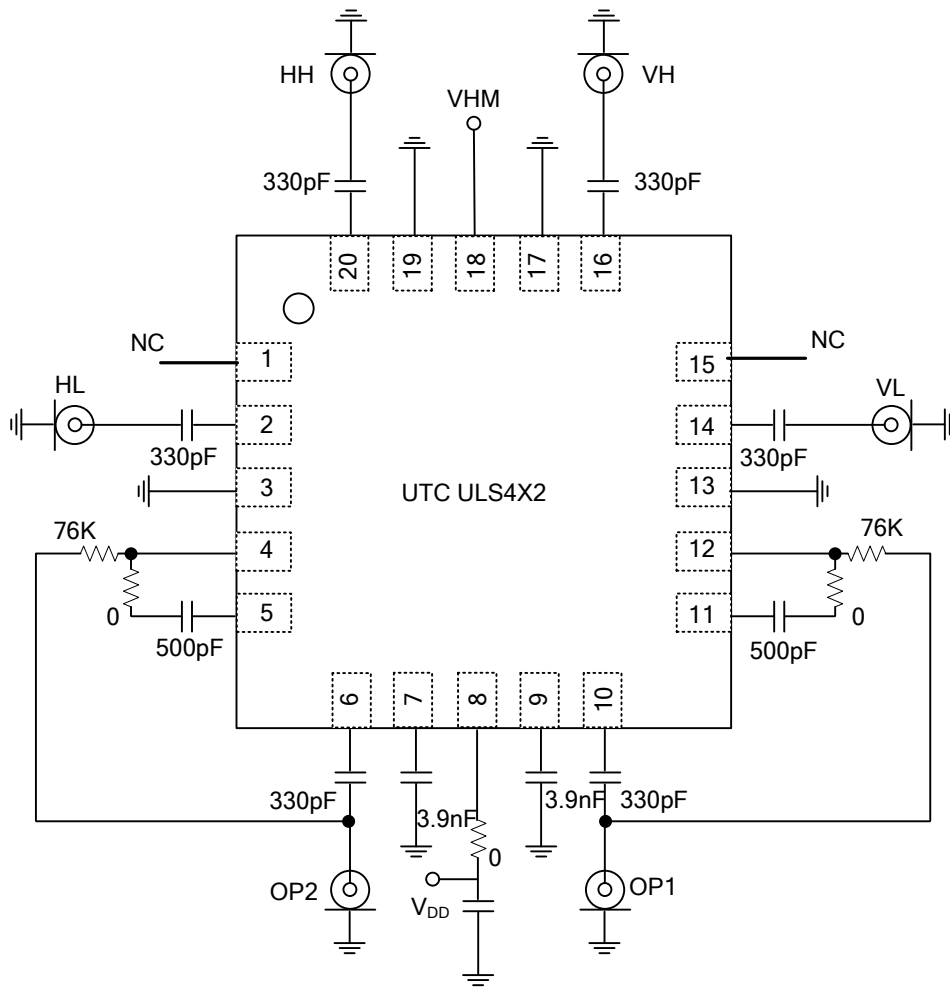

■ TRUTH TABLE

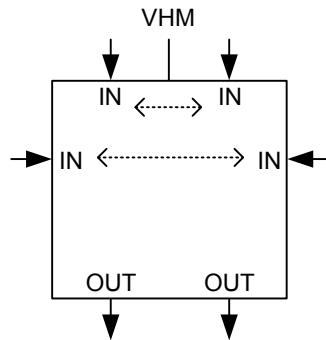

Above Figure Show the Function of VHM. (Vertical/Horizontal Mirror)

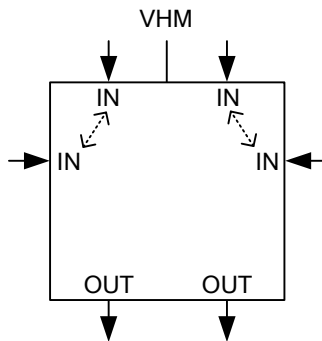

Above Figure Show the Different Between UTC ULS4X2A and UTC ULS4X2B (High/low Band Upside Down)

V1, V2=0 means DC voltage=9.5~14V, V1, V2=1 means DC voltage=15.5~19V
 T1, T2=0 means 22KHz tone disappeared. T1, T2=1 means 22KHz tone appeared.

UTC **ULS4X2A** When pin 18 "VHM" connected to GND

State	CONTROL INPUT				OUTPUT TO INPUT STATE	
	V1	T 1	V2	T2	OP1	OP2
1	0	0	0	0	HH	HH
2	0	0	0	1	HH	HL
3	0	0	1	0	HH	VH
4	0	0	1	1	HH	VL
5	0	1	0	0	HL	HH
6	0	1	0	1	HL	HL
7	0	1	1	0	HL	VH
8	0	1	1	1	HL	VL
9	1	0	0	0	VH	HH
10	1	0	0	1	VH	HL
11	1	0	1	0	VH	VH
12	1	0	1	1	VH	VL
13	1	1	0	0	VL	HH
14	1	1	0	1	VL	HL
15	1	1	1	0	VL	VH
16	1	1	1	1	VL	VL

■ TRUTH TABLE (Cont.)

UTC **ULS4X2A** When pin 18 "VHM" open. Vertical and Horizontal will be mirror

State	CONTROL INPUT				OUTPUT TO INPUT STATE	
	V1	T 1	V2	T2	OP1	OP2
1	0	0	0	0	VH	VH
2	0	0	0	1	VH	VL
3	0	0	1	0	VH	HH
4	0	0	1	1	VH	HL
5	0	1	0	0	VL	VH
6	0	1	0	1	VL	VL
7	0	1	1	0	VL	HH
8	0	1	1	1	VL	HL
9	1	0	0	0	HH	VH
10	1	0	0	1	HH	VL
11	1	0	1	0	HH	HH
12	1	0	1	1	HH	HL
13	1	1	0	0	HL	VH
14	1	1	0	1	HL	VL
15	1	1	1	0	HL	HH
16	1	1	1	1	HL	HL

UTC **ULS4X2B** When pin 18 "VHM" connected to GND

State	CONTROL INPUT				OUTPUT TO INPUT STATE	
	V1	T 1	V2	T2	OP1	OP2
1	0	0	0	0	HL	HL
2	0	0	0	1	HL	HH
3	0	0	1	0	HL	VL
4	0	0	1	1	HL	VH
5	0	1	0	0	HH	HL
6	0	1	0	1	HH	HH
7	0	1	1	0	HH	VL
8	0	1	1	1	HH	VH
9	1	0	0	0	VL	HL
10	1	0	0	1	VL	HH
11	1	0	1	0	VL	VL
12	1	0	1	1	VL	VH
13	1	1	0	0	VH	HL
14	1	1	0	1	VH	HH
15	1	1	1	0	VH	VL
16	1	1	1	1	VH	VH

■ TRUTH TABLE (Cont.)

UTC **ULS4X2B** When pin 18 "VHM" open. Vertical and Horizontal will be mirror

State	CONTROL INPUT				OUTPUT TO INPUT STATE	
	V1	T 1	V2	T2	OP1	OP2
1	0	0	0	0	VL	VL
2	0	0	0	1	VL	VH
3	0	0	1	0	VL	HL
4	0	0	1	1	VL	HH
5	0	1	0	0	VH	VL
6	0	1	0	1	VH	VH
7	0	1	1	0	VH	HL
8	0	1	1	1	VH	HH
9	1	0	0	0	HL	VL
10	1	0	0	1	HL	VH
11	1	0	1	0	HL	HL
12	1	0	1	1	HL	HH
13	1	1	0	0	HH	VL
14	1	1	0	1	HH	VH
15	1	1	1	0	HH	HL
16	1	1	1	1	HH	HH

UTC assumes no responsibility for equipment failures that result from using products at values that exceed, even momentarily, rated values (such as maximum ratings, operating condition ranges, or other parameters) listed in products specifications of any and all UTC products described or contained herein. UTC products are not designed for use in life support appliances, devices or systems where malfunction of these products can be reasonably expected to result in personal injury. Reproduction in whole or in part is prohibited without the prior written consent of the copyright owner. The information presented in this document does not form part of any quotation or contract, is believed to be accurate and reliable and may be changed without notice.