

● SPECIFICATION

Frequency Range	4.500 - 100.000MHz
Vibration Mode	AT-Cut Fundamental Thir , Fifth
Frequency Tolerance(25°C)	±5,±10,±20PPM
Frequency Stability	±10,±20,±30,±50PPM
Operation Temperature	-20°C ~ +60°C
Load Capacitance	16,20,30pF or Special
Shunt Capacitance	7pF or Special
Drive Level	50,100,300,500,1000 μW
Insulation Resistance	500M Ω min/DC
Aging	±3,±5PPM/year

● EQUIVALENT SERIES RESISTANCE

Frequency (MHz)	ESR (Ω) max
Fundamental	
4.500 - 5.999MHz	200
6.000 - 7.999MHz	150
8.000 - 9.999MHz	120
10.000 - 11.999MHz	40
12.000 - 15.999MHz	35
16.000 - 19.999MHz	25
20.000 - 26.000MHz	20
3rd Overtone	
26.000 - 39.000MHz	50
40.000 - 100.000MHz	45

● DIMENSIONS(mm)

UM-1,UM-5

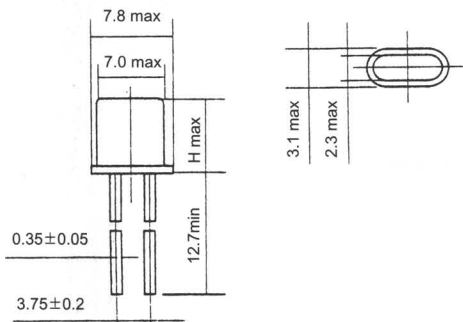

UM-1J,UM-5J

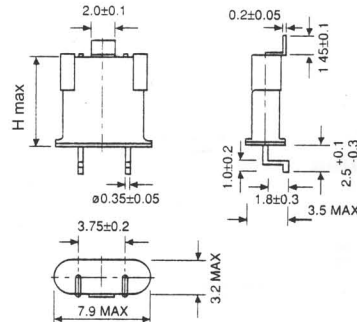

H	UM-1	8.0
	UM-5	5.8

● SPECIFICATION

Frequency Range	150 - 25000KHz
Vibration Mode	150K~400KHz DT Cut 400K~500KHz CT Cut 850K~25000KHz AT Cut
Frequency Tolerance	±30PPM at 25°C
Drive Level	2,4mW
Aging	±7PPM/year

● DIMENSIONS(mm)

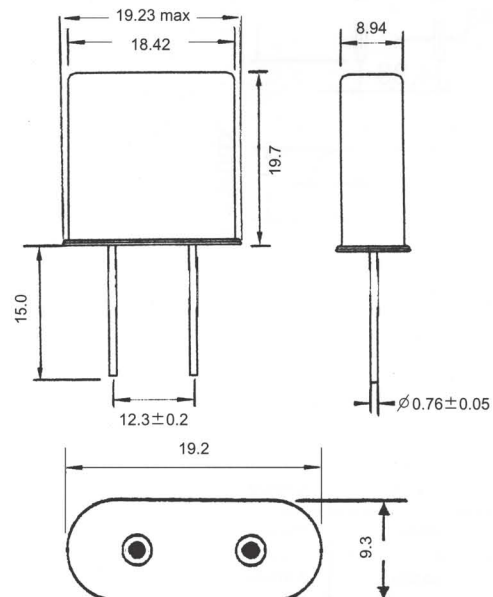

● EQUIVALENT SERIES RESISTANCE

Frequency (KHz)	ESR (KΩ)
150~500K	8
850K~999K	0.3 ~ 0.6
1000K~25000K	0.02~03