

300mA, Low Power Consumption, Wide Input Voltage Range Linear Regulator

UM1451S-xx SOT23-3
UM1451Y-xx SOT89-3
UM1451B-xx SOT89-3
UM1461S-xx SOT23-5
UM1461Y-xx SOT89-5

General Description

The UM1451/UM1461 series are a group of positive voltage output, high precision and low power consumption voltage regulators. The maximum input voltage is 24V. The output voltages are available in 100mV steps within a range of 2.5V to 5V. It can also be customized on request.

The UM1451/UM1461 series have very low power consumption ($I_Q=3.5\mu A$) which can greatly extend battery life.

The UM1451 series are available in low profile SOT23-3 & SOT89-3 packages. The UM1461 series are available in SOT23-5 & SOT89-5 packages.

Applications

- Battery-Powered Equipment
- Power Management of MP3, PDA, DSC, Mouse, PS2 Games
- Reference Voltage Source
- Hand-Hold Equipment

Features

- Maximum Input Voltage: 24V
- Low Quiescent Current: 3.5 μA (Typ.)
- Maximum Output Current: 300mA
- Low Dropout:
250mV@100mA ($V_{OUT}=3.3V$)
500mV@200mA ($V_{OUT}=3.3V$)
- Low Temperature Coefficient: $\pm 150ppm/^{\circ}C$
- Output Current Limit:
400mA@ $V_{OUT}=3.3V$

Pin Configurations

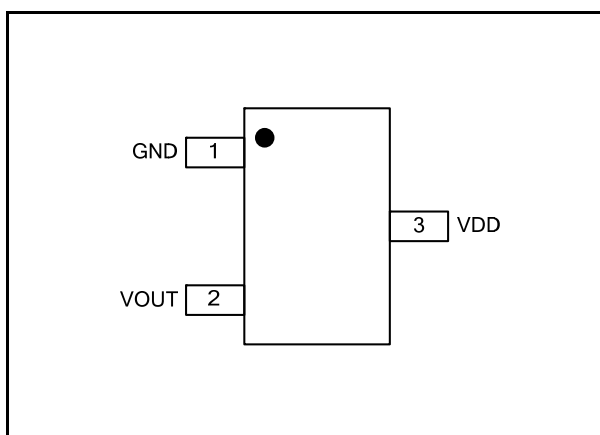

Top View

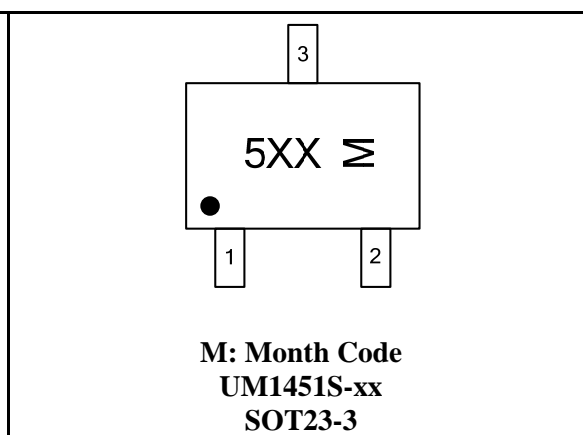

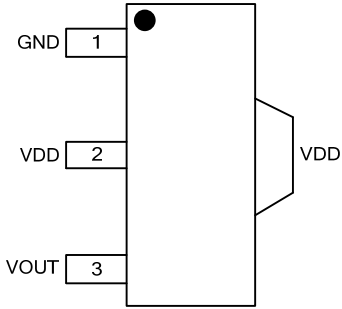
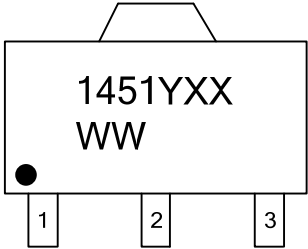
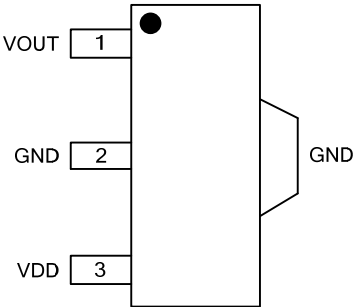
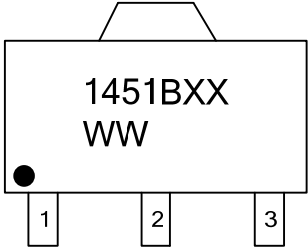
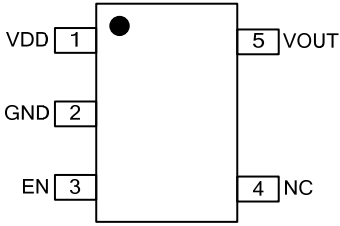
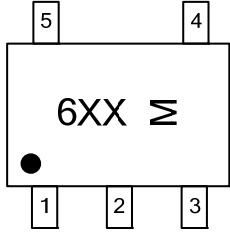
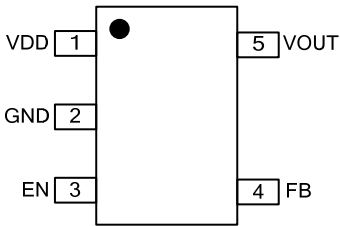
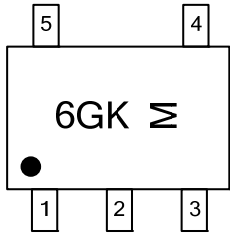
 <p>TAB Connected to Pin 2</p>	 <p>WW: Week Code UM1451Y-xx SOT89-3</p>
 <p>TAB Connected to Pin 2</p>	 <p>WW: Week Code UM1451B-xx SOT89-3</p>
	 <p>M: Month Code UM1461S-xx SOT23-5</p>
	 <p>M: Month Code UM1461S-00 SOT23-5</p>

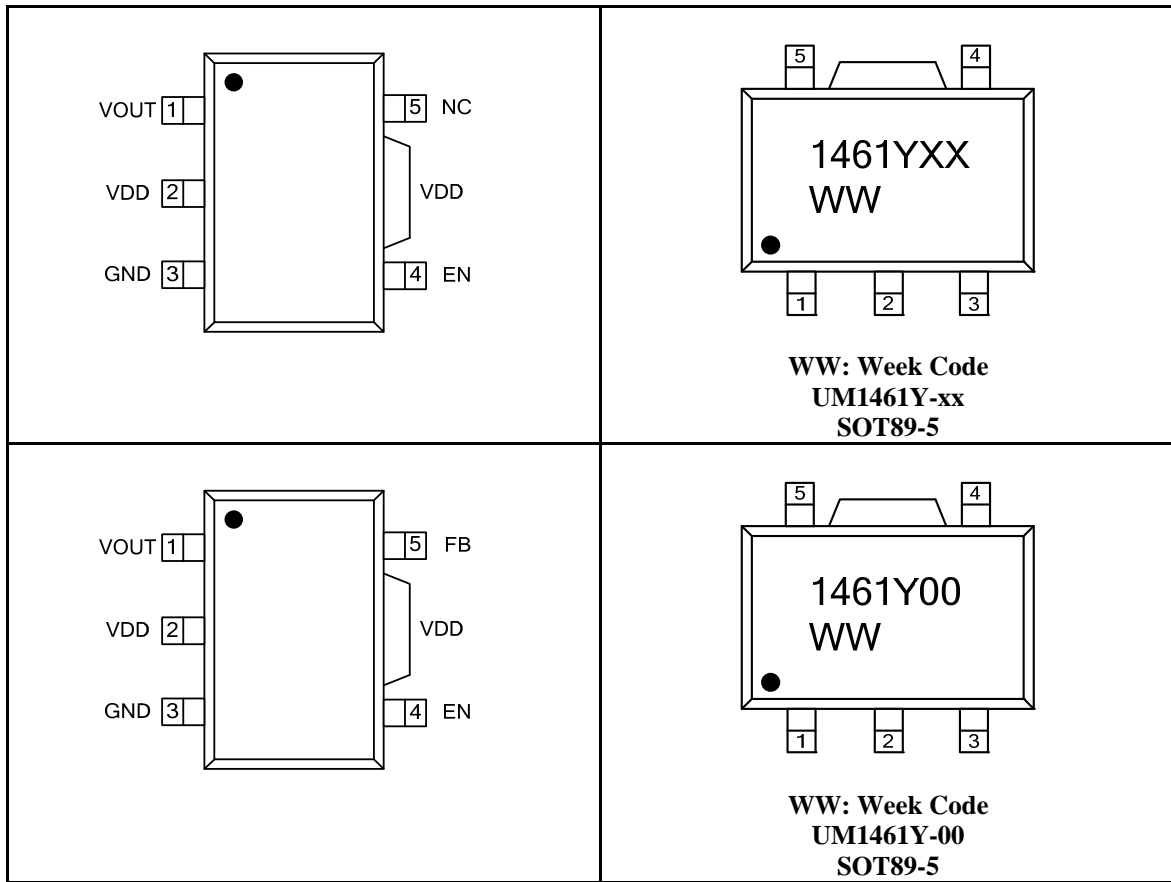

Ordering Information

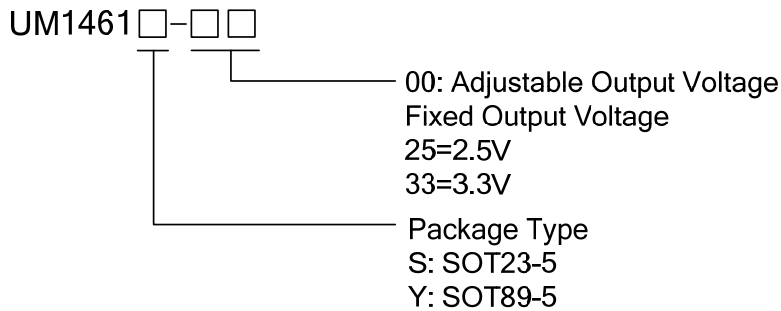
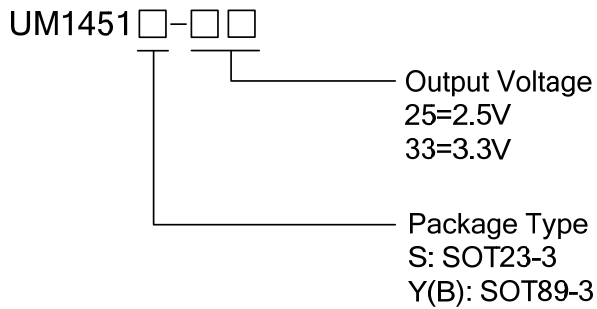

Marking Information

Part Number	Output Voltage	Packaging Type	Marking Code	Shipping Qty		
UM1451S-25	2.5V	SOT23-3	5M2	3000pcs/7Inch Tape & Reel		
UM1451S-26	2.6V		5MB			
UM1451S-27	2.7V		5MC			
UM1451S-28	2.8V		5MD			
UM1451S-29	2.9V		5ME			
UM1451S-30	3.0V		5MF			
UM1451S-31	3.1V		5MH			
UM1451S-32	3.2V		5ML			
UM1451S-33	3.3V		5MM			
UM1451S-34	3.4V		5MJ			
UM1451S-35	3.5V		5MK			
UM1451S-36	3.6V		5MN			
UM1451S-37	3.7V		5MP			
UM1451S-38	3.8V		5MQ			
UM1451S-39	3.9V		5MR			
UM1451S-40	4.0V		5MS			
UM1451S-41	4.1V		5MT			
UM1451S-42	4.2V		5MY			
UM1451S-43	4.3V		5MU			
UM1451S-44	4.4V		5MZ			
UM1451S-45	4.5V		5U5			
UM1451S-46	4.6V		5U6			
UM1451S-47	4.7V		5U7			
UM1451S-48	4.8V		5U8			
UM1451S-49	4.9V		5U9			
UM1451S-50	5.0V		5UA			
UM1451Y-25	2.5V		SOT89-3 (Tab connected to VDD)		1451Y25	1000pcs/7Inch Tape & Reel
UM1451Y-26	2.6V				1451Y26	
UM1451Y-27	2.7V				1451Y27	
UM1451Y-28	2.8V				1451Y28	
UM1451Y-29	2.9V	1451Y29				
UM1451Y-30	3.0V	1451Y30				
UM1451Y-31	3.1V	1451Y31				
UM1451Y-32	3.2V	1451Y32				
UM1451Y-33	3.3V	1451Y33				
UM1451Y-34	3.4V	1451Y34				
UM1451Y-35	3.5V	1451Y35				
UM1451Y-36	3.6V	1451Y36				
UM1451Y-37	3.7V	1451Y37				
UM1451Y-38	3.8V	1451Y38				
UM1451Y-39	3.9V	1451Y39				
UM1451Y-40	4.0V	1451Y40				
UM1451Y-41	4.1V	1451Y41				
UM1451Y-42	4.2V	1451Y42				
UM1451Y-43	4.3V	1451Y43				
UM1451Y-44	4.4V	1451Y44				
UM1451Y-45	4.5V	1451Y45				
UM1451Y-46	4.6V	1451Y46				
UM1451Y-47	4.7V	1451Y47				
UM1451Y-48	4.8V	1451Y48				
UM1451Y-49	4.9V	1451Y49				
UM1451Y-50	5.0V	1451Y50				

Marking Information (Continued)

Part Number	Output Voltage	Packaging Type	Marking Code	Shipping Qty
UM1451B-25	2.5V	SOT89-3 (Tab connected to GND)	1451B25	1000pcs/7Inch Tape & Reel
UM1451B-26	2.6V		1451B26	
UM1451B-27	2.7V		1451B27	
UM1451B-28	2.8V		1451B28	
UM1451B-29	2.9V		1451B29	
UM1451B-30	3.0V		1451B30	
UM1451B-31	3.1V		1451B31	
UM1451B-32	3.2V		1451B32	
UM1451B-33	3.3V		1451B33	
UM1451B-34	3.4V		1451B34	
UM1451B-35	3.5V		1451B35	
UM1451B-36	3.6V		1451B36	
UM1451B-37	3.7V		1451B37	
UM1451B-38	3.8V		1451B38	
UM1451B-39	3.9V		1451B39	
UM1451B-40	4.0V		1451B40	
UM1451B-41	4.1V		1451B41	
UM1451B-42	4.2V		1451B42	
UM1451B-43	4.3V		1451B43	
UM1451B-44	4.4V		1451B44	
UM1451B-45	4.5V		1451B45	
UM1451B-46	4.6V		1451B46	
UM1451B-47	4.7V		1451B47	
UM1451B-48	4.8V		1451B48	
UM1451B-49	4.9V		1451B49	
UM1451B-50	5.0V		1451B50	

Marking Information (Continued)

Part Number	Output Voltage	Packaging Type	Marking Code	Shipping Qty
UM1461S-00	ADJ	SOT23-5	6GK	3000pcs/7Inch Tape & Reel
UM1461S-25	2.5V		6DC	
UM1461S-26	2.6V		6DD	
UM1461S-27	2.7V		6DE	
UM1461S-28	2.8V		6DF	
UM1461S-29	2.9V		6DH	
UM1461S-30	3.0V		6DL	
UM1461S-31	3.1V		6DM	
UM1461S-32	3.2V		6DJ	
UM1461S-33	3.3V		6DK	
UM1461S-34	3.4V		6DN	
UM1461S-35	3.5V		6DP	
UM1461S-36	3.6V		6DQ	
UM1461S-37	3.7V		6DR	
UM1461S-38	3.8V		6DS	
UM1461S-39	3.9V		6DT	
UM1461S-40	4.0V		6DY	
UM1461S-41	4.1V		6DU	
UM1461S-42	4.2V		6DZ	
UM1461S-43	4.3V		6GC	
UM1461S-44	4.4V		6GD	
UM1461S-45	4.5V		6GE	
UM1461S-46	4.6V		6GF	
UM1461S-47	4.7V		6GH	
UM1461S-48	4.8V		6GL	
UM1461S-49	4.9V		6GM	
UM1461S-50	5.0V		6GJ	

Marking Information (Continued)

Part Number	Output Voltage	Packaging Type	Marking Code	Shipping Qty
UM1461Y-00	ADJ	SOT89-5 (Tab connected to VDD)	1461Y00	1000pcs/7Inch Tape & Reel
UM1461Y-25	2.5V		1461Y25	
UM1461Y-26	2.6V		1461Y26	
UM1461Y-27	2.7V		1461Y27	
UM1461Y-28	2.8V		1461Y28	
UM1461Y-29	2.9V		1461Y29	
UM1461Y-30	3.0V		1461Y30	
UM1461Y-31	3.1V		1461Y31	
UM1461Y-32	3.2V		1461Y32	
UM1461Y-33	3.3V		1461Y33	
UM1461Y-34	3.4V		1461Y34	
UM1461Y-35	3.5V		1461Y35	
UM1461Y-36	3.6V		1461Y36	
UM1461Y-37	3.7V		1461Y37	
UM1461Y-38	3.8V		1461Y38	
UM1461Y-39	3.9V		1461Y39	
UM1461Y-40	4.0V		1461Y40	
UM1461Y-41	4.1V		1461Y41	
UM1461Y-42	4.2V		1461Y42	
UM1461Y-43	4.3V		1461Y43	
UM1461Y-44	4.4V		1461Y44	
UM1461Y-45	4.5V		1461Y45	
UM1461Y-46	4.6V		1461Y46	
UM1461Y-47	4.7V		1461Y47	
UM1461Y-48	4.8V		1461Y48	
UM1461Y-49	4.9V		1461Y49	
UM1461Y-50	5.0V	1461Y50		

Pin Description

Symbol	Function
GND	Ground
VOUT	Voltage Regulated Output
EN	Enable Control Input: High=Activate LDO, Low=Shutdown LDO
VDD	Supply Voltage Input
FB	Output Voltage Feedback

Absolute Maximum Ratings (Note 1)

Symbol	Parameter	Value	Unit
V _{IN}	Max Input Voltage	28	V
P _D	Power Dissipation	SOT23-3	250
		SOT23-5	300
		SOT89-3	1000
		SOT89-5	1200
T _J	Operating Junction Temperature	+125	°C
T _A	Ambient Temperature	-40 to +85	°C
T _{STG}	Storage Temperature Range	-40 to +150	°C
T _L	Lead Temperature for Soldering 10 Seconds	+260	°C

Note 1: Exposure to absolute maximum rating conditions may affect device reliability.

Recommended Work Condition

Symbol	Parameter	Value	Unit
V _{IN}	Max Input Voltage	24	V

Electrical Characteristics

 (Test conditions: $C_{IN}=1.0\mu F$, $C_{OUT}=1.0\mu F$, $T_A=25^\circ C$, unless otherwise noted)

Symbol	Parameter	Test Conditions	Min	Typ	Max	Unit
V_{IN}	Input Voltage		3.6		24	V
V_{OUT}	Output Voltage	$V_{IN}=\text{Set } V_{OUT}+1V$ $1mA \leq I_{OUT} \leq 10mA$	$V_{OUT} \times 0.98$	$V_{OUT} \times 1.0$	$V_{OUT} \times 1.02$	V
V_{FB}	Feedback Reference Voltage	$V_{IN}=3.6V$ to 24V	1.176	1.2	1.224	V
I_{FB}	Feedback Reference Current	$V_{FB}=1.2V$			10	nA
$I_{OUT}(\text{Max})$ (Note 2)	Maximum Output Current	$V_{IN}-V_{OUT}=1V$	300			mA
V_{DROP}	Dropout Voltage	$I_{OUT}=150mA$		380		mV
	Output Voltage Accuracy	$I_{OUT}=300mA$	-3		+3	%
$\frac{\Delta V_{OUT}}{\Delta V_{IN} \cdot V_{OUT}}$	Line Regulation	$I_{OUT}=10mA$ $4V \leq V_{DD} \leq 6V$		0.05	0.2	%/V
ΔV_{OUT}	Load Regulation	$V_{IN}=\text{Set } V_{OUT}+1V$ $1mA \leq I_{OUT} \leq 300mA$		20		mV
I_S	Supply Current	$V_{IN}=\text{Set } V_{OUT}+1V$ V_{OUT} Floating		3.5	5	μA
	Shut Down Quiescent Current	$V_{IN}=8V$, EN= GND			1	μA
I_{EN}	EN Input Current	EN= V_{IN} or GND			1	μA
$\frac{\Delta V_{OUT}}{\Delta T \cdot V_{OUT}}$	Output Voltage Noise	$I_{OUT}=10mA$		± 150		ppm/ $^\circ C$
I_{LIMIT}	Output Current Limit	$R_L=1\Omega$	350	450	600	mA
t	Startup Time Response	$V_{OUT}=3.3V$, $R_L=68\Omega$, $C_{OUT}=1\mu F$		80		μs
V_{IL}	EN Input Low Voltage	$V_{IN}=3.6V$ to 24V			0.8	V
V_{IH}	EN Input High Voltage	$V_{IN}=3.6V$ to 24V	1.8			V
PSRR	Power Supply Ripple Rejection	Ripple=1 Vp-p, $V_{IN}=\text{Set } V_{OUT}+1V$	f=100Hz		72	dB
			f=1kHz		71	
			f=10kHz		56	
	Output Noise	BW=10Hz~100kHz $V_{out}=2.5V$		80		μV_{RMS}

Note 2: The maximum power rating of each package is constant, so along with the change of I_{LOAD} , the $V_{IN}-V_{OUT}$ should be controlled to a certain range to ensure the normal operation.

Typical Application Circuit

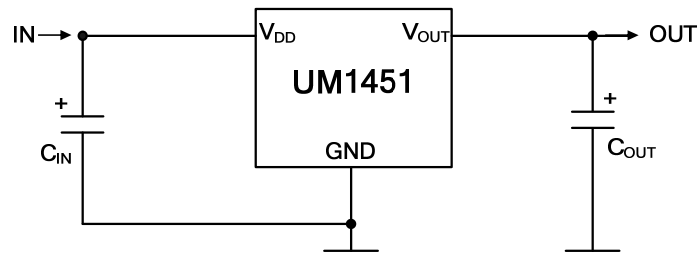

Figure 1

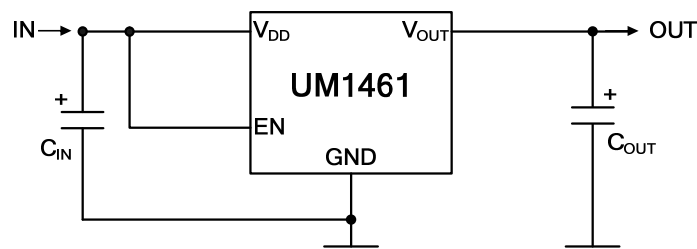

Figure 2

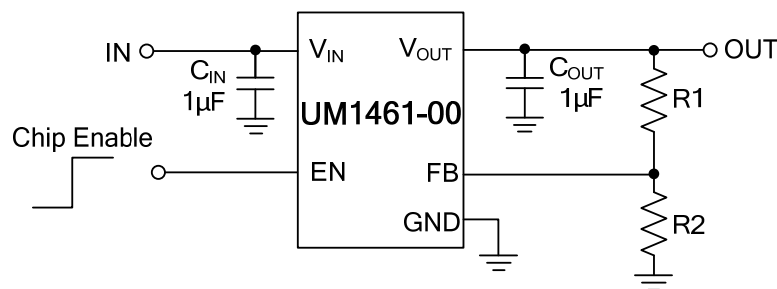

Figure 3

Note 3: Input Capacitor ($C_{IN}=1\mu F$) is recommended in all applications.

Note 4: Output Capacitor ($C_{OUT}=4.7\mu F/6.8\mu F$) is recommended in all applications to assure the stability of circuit.

UM1461S-00/UM1461Y-00 Output Voltage Setting

The output voltage of the UM1461 adjustable regulator is programmed using an external resistor divider as shown in Figure 3. The output voltage is calculated using:

$$V_{OUT} = V_{FB} \left(1 + \frac{R1}{R2} \right)$$

Where: $V_{FB}=1.2V$ (Typ) (the internal reference voltage)

Resistors R1 and R2 should be chosen for approximately 3-5µA divider current. Lower value resistors can be used but offer no inherent advantage and waste more power. Higher values should be avoided, as leakage currents at FB increase the output voltage error. The recommended design procedure is to choose $R2=200k\Omega$ to set the divider current at 5µA and then calculate R1 using:

$$R1 = \left(\frac{V_{OUT}}{V_{FB}} - 1 \right) \times R2$$

Where: $V_{FB}=1.2V$ (Typ).

Typical Operating Characteristics

Quiescent Current vs. Input Voltage

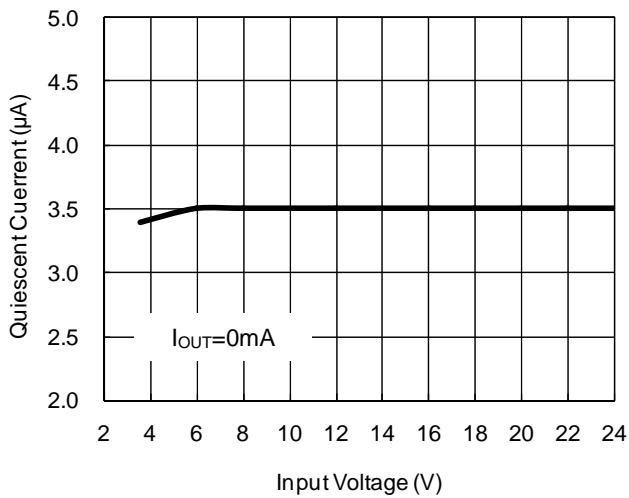

Output Voltage vs. Input Voltage

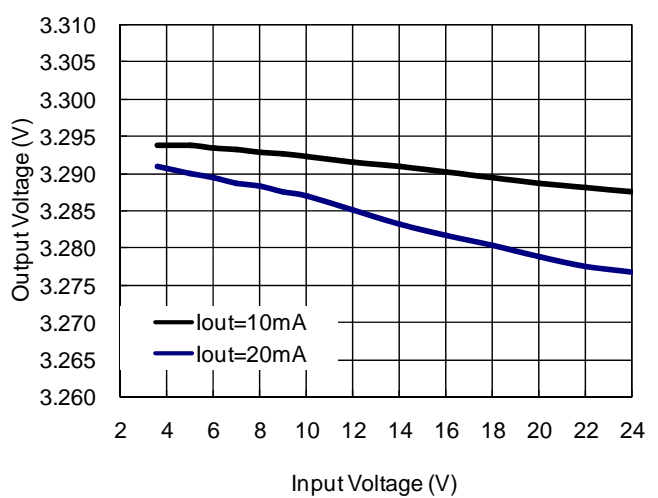

Output Voltage vs. Output Current

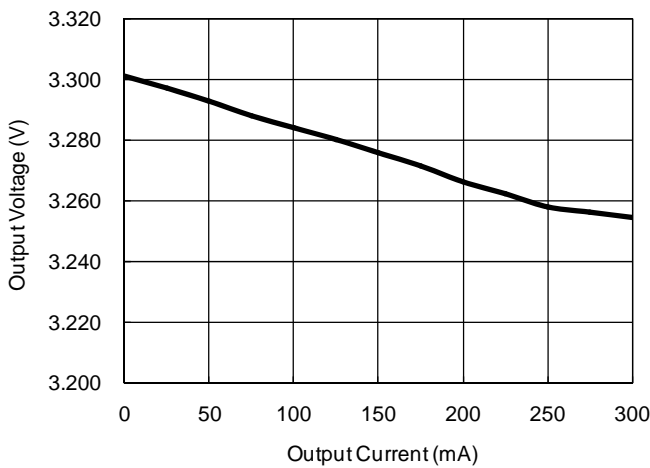

Dropout Voltage vs. Output Current

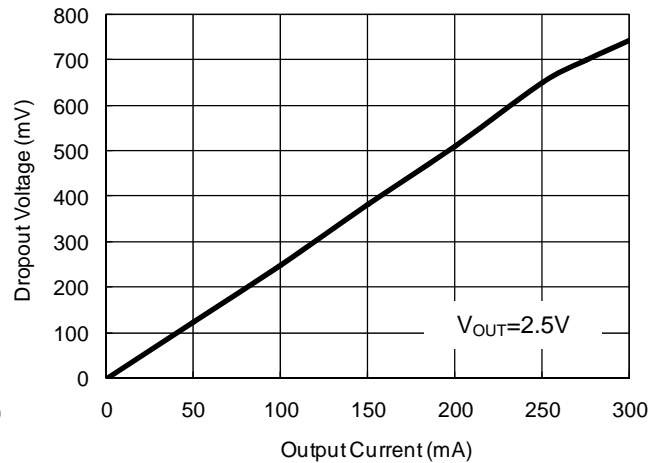

Ground Current vs. Output Current

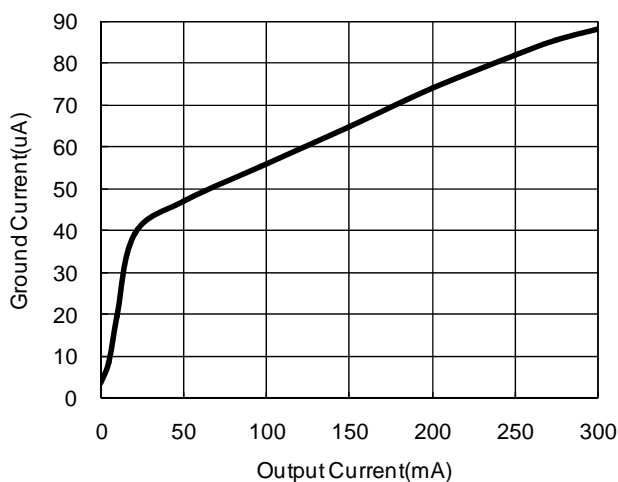

Enable Threshold Voltage vs. Input Voltage

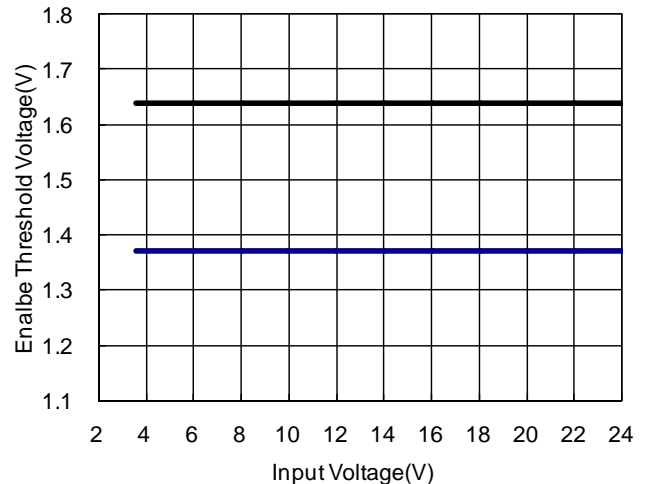

Typical Operating Characteristics (Continued)

Output Voltage vs. Temperature

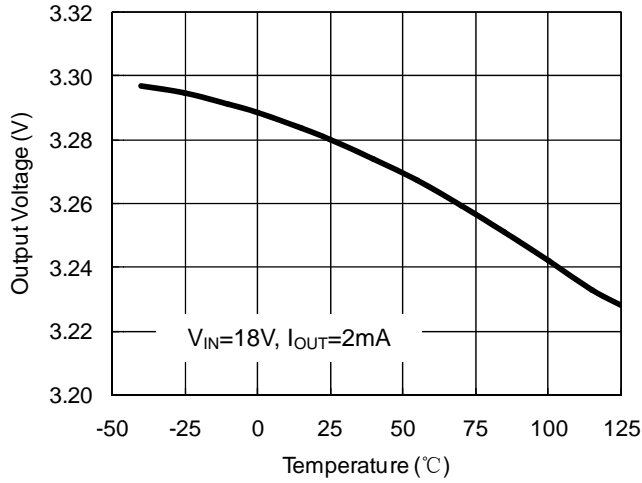

Quiescent Current vs. Temperature

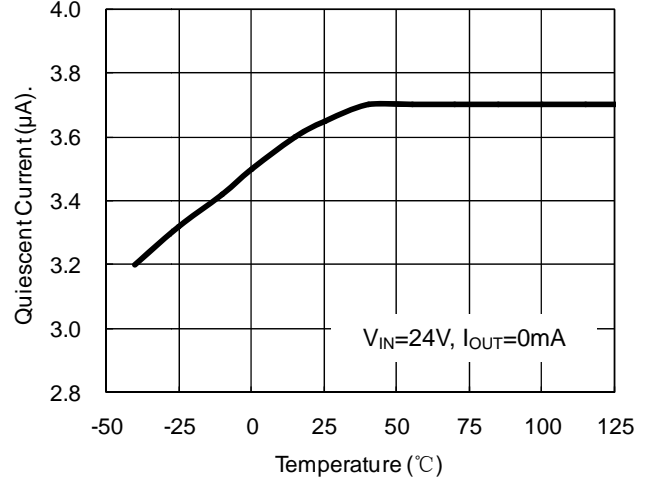

PSRR vs. Frequency

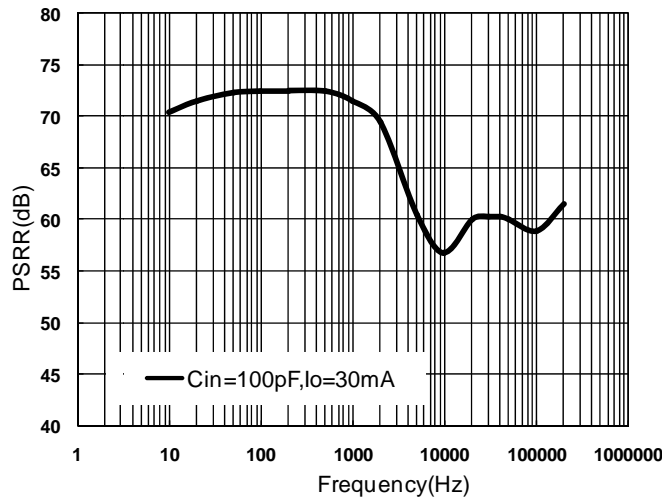

Line Transient Response

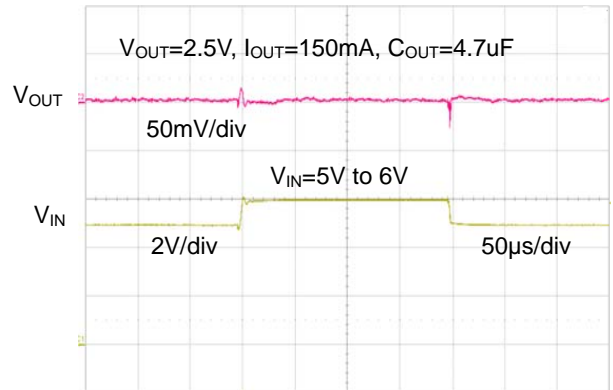

Load Transient Response

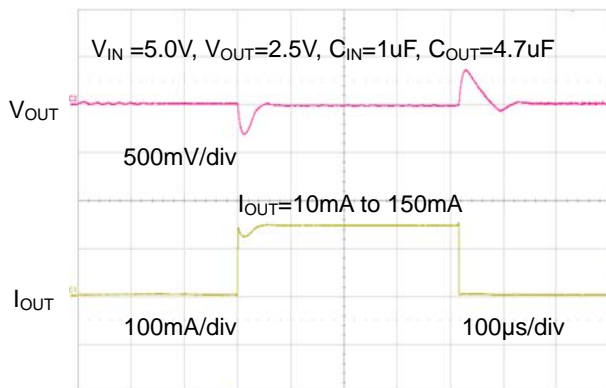

Noise

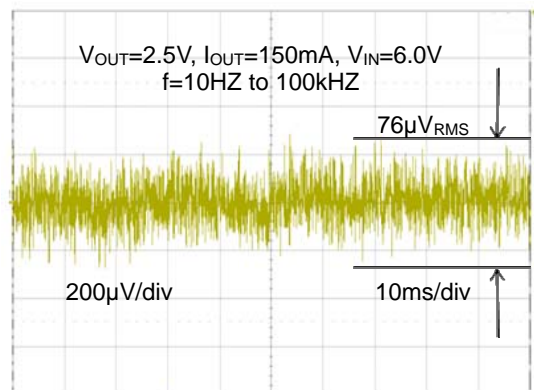

Package Information

UM1451S-xx: SOT23-3

Outline Drawing

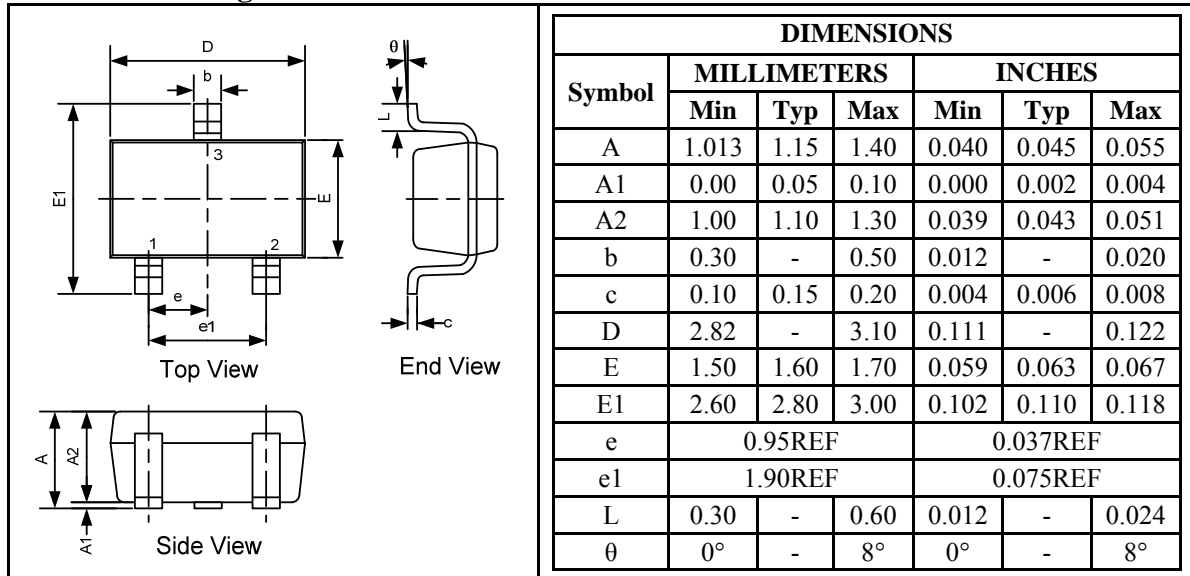

Land Pattern

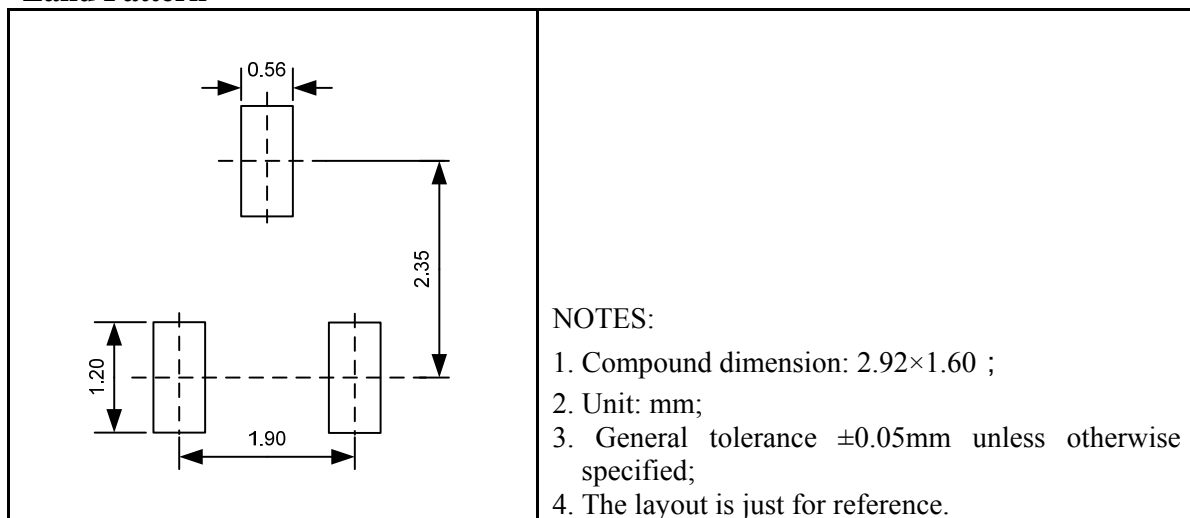

Tape and Reel Orientation



UM1451Y-xx: SOT89-3

Outline Drawing

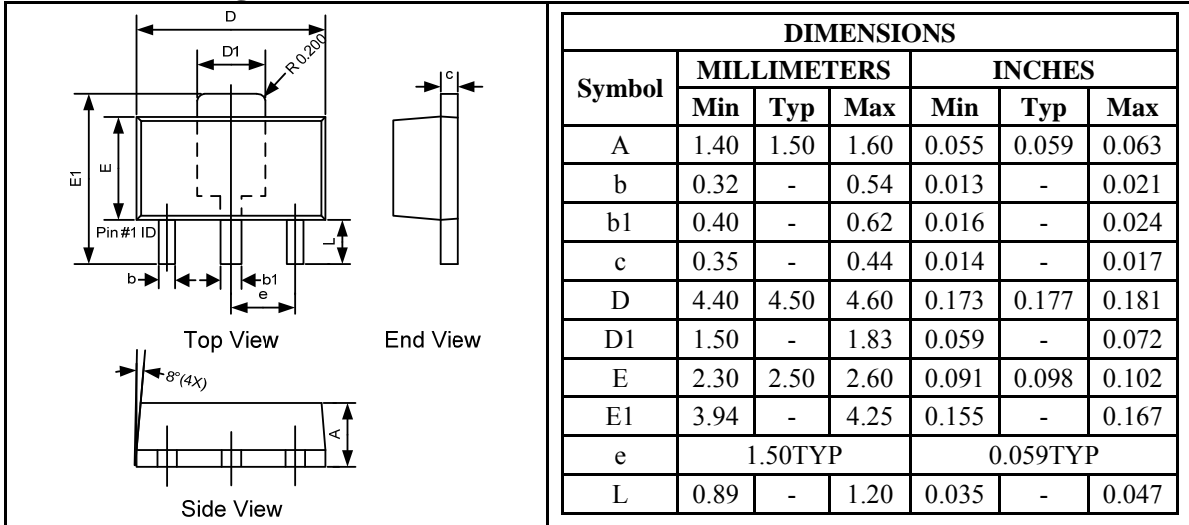

Land Pattern

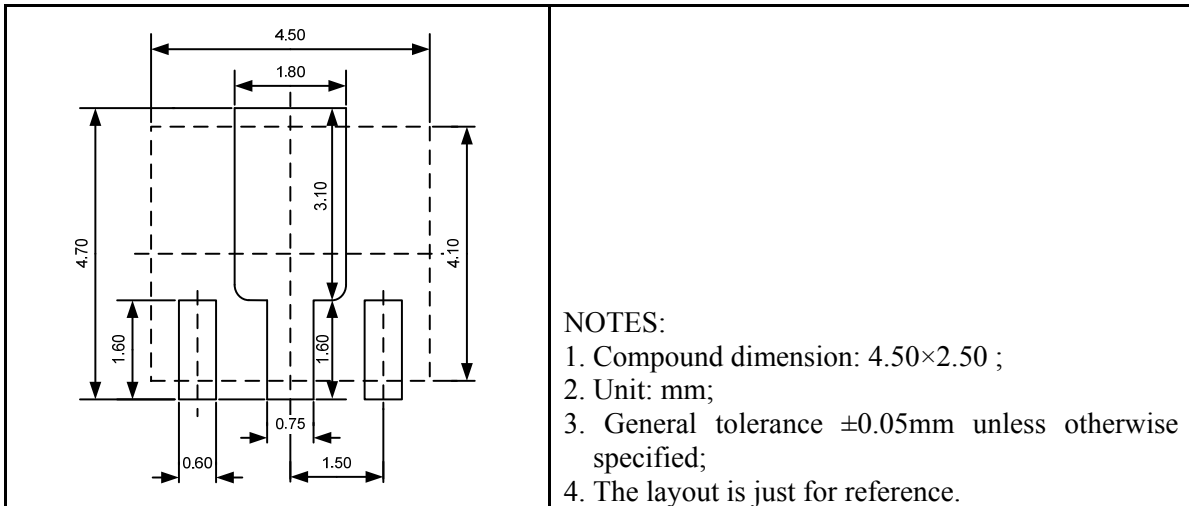

Tape and Reel Orientation

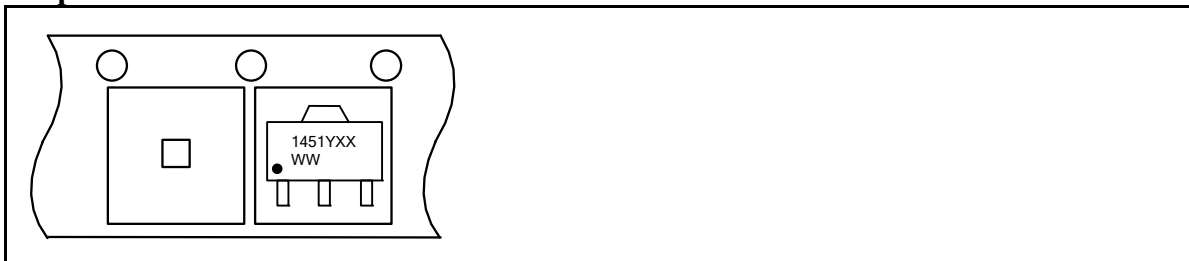

UM1451B-xx: SOT89-3

Outline Drawing

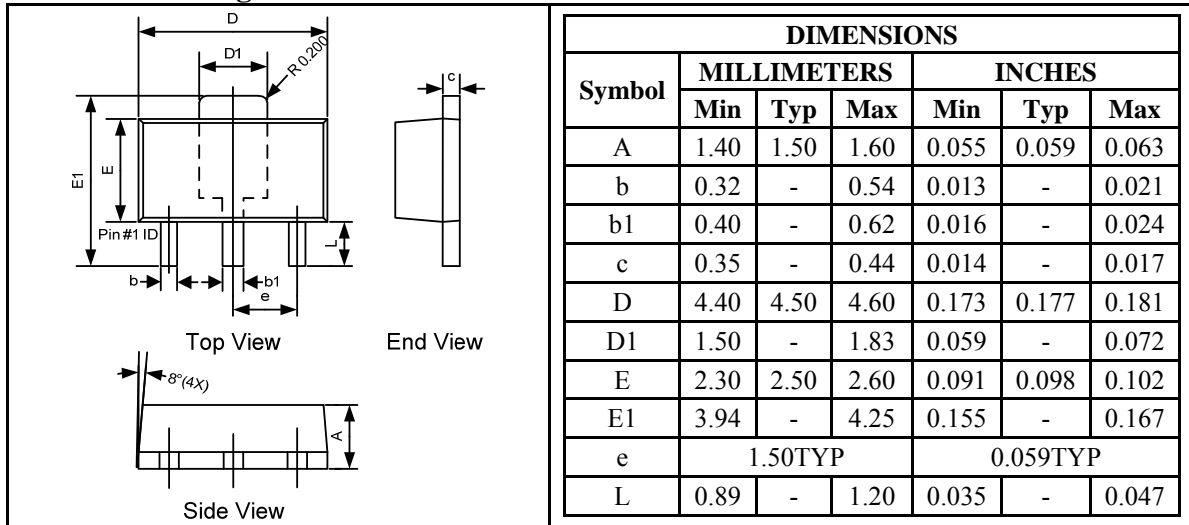

Land Pattern

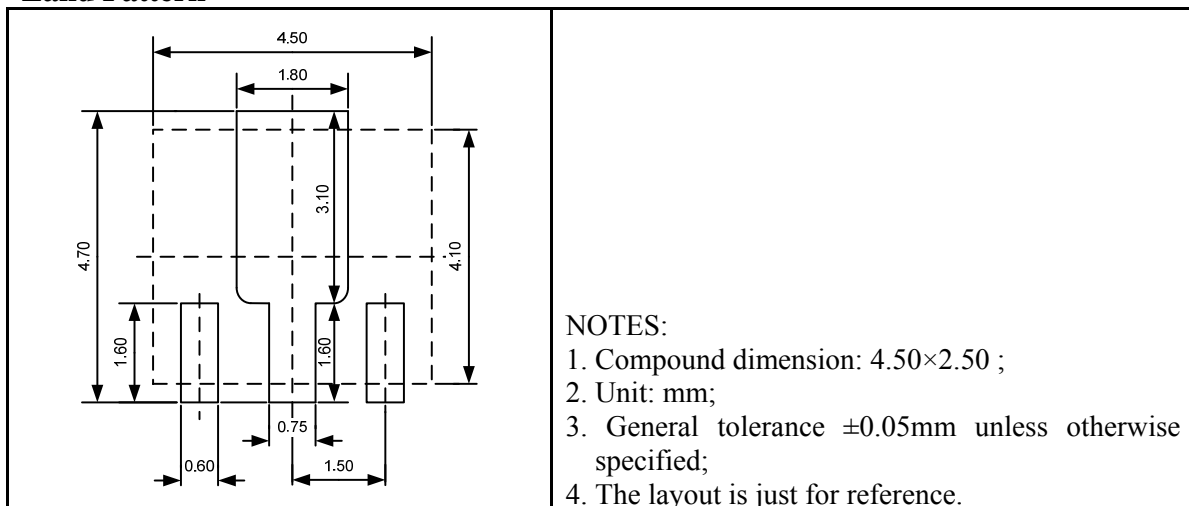

Tape and Reel Orientation

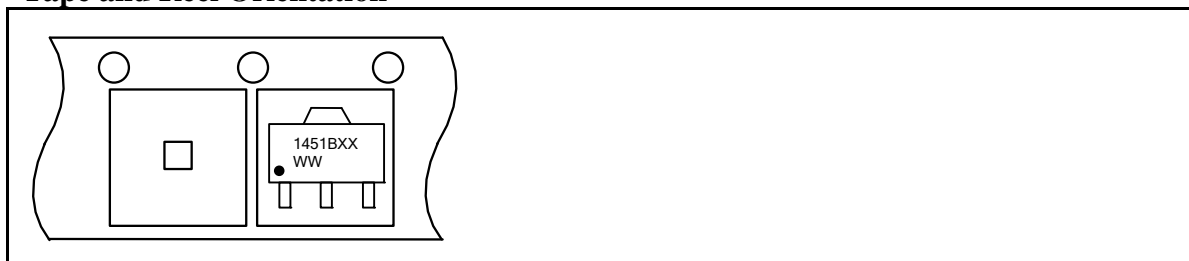

UM1461S: SOT23-5

Outline Drawing

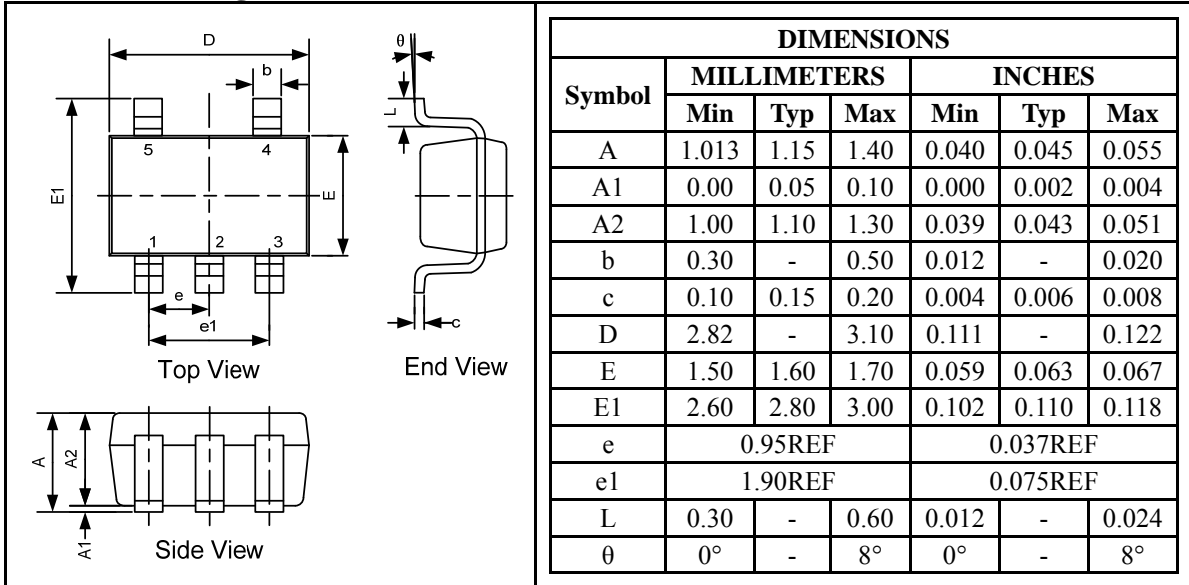

Land Pattern

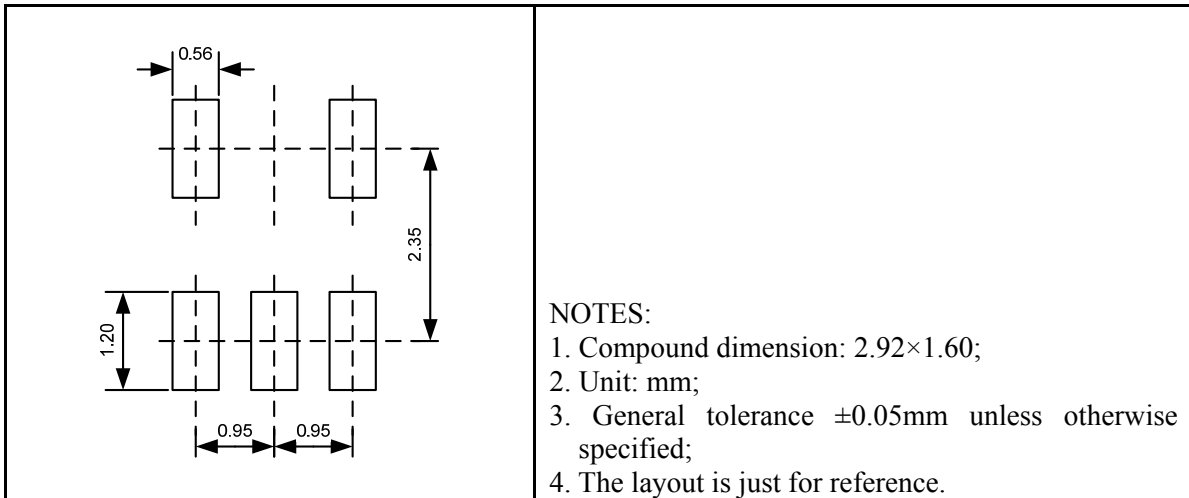

Tape and Reel Orientation



UM1461Y-xx: SOT89-5

Outline Drawing

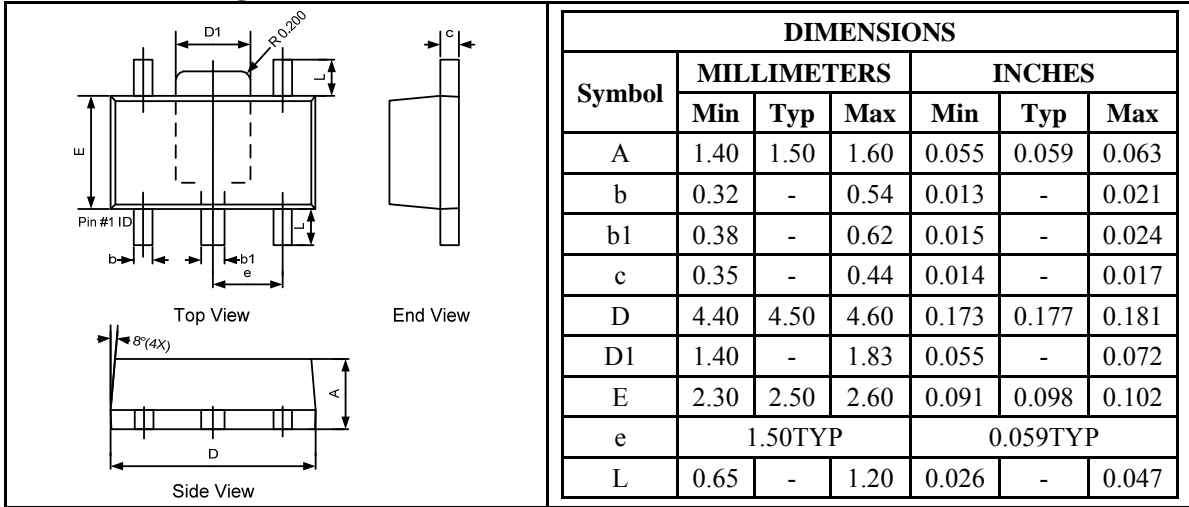

Land Pattern

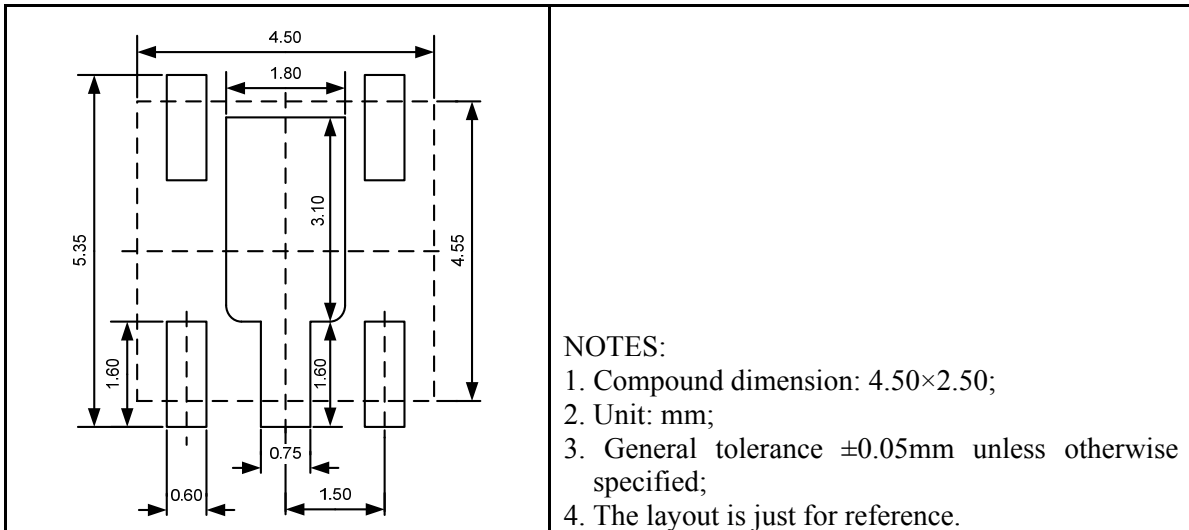

Tape and Reel Orientation



GREEN COMPLIANCE

Union Semiconductor is committed to environmental excellence in all aspects of its operations including meeting or exceeding regulatory requirements with respect to the use of hazardous substances. Numerous successful programs have been implemented to reduce the use of hazardous substances and/or emissions.

All Union components are compliant with the RoHS directive, which helps to support customers in their compliance with environmental directives. For more green compliance information, please visit:

http://www.union-ic.com/index.aspx?cat_code=RoHSDeclaration

IMPORTANT NOTICE

The information in this document has been carefully reviewed and is believed to be accurate. Nonetheless, this document is subject to change without notice. Union assumes no responsibility for any inaccuracies that may be contained in this document, and makes no commitment to update or to keep current the contained information, or to notify a person or organization of any update. Union reserves the right to make changes, at any time, in order to improve reliability, function or design and to attempt to supply the best product possible.



Union Semiconductor, Inc

Add: Unit 606, No.570 Shengxia Road, Shanghai 201210

Tel: 021-51093966

Fax: 021-51026018

Website: www.union-ic.com