

300mA, Micropower, VLDO Linear Regulator

UM165xx SOT23-3

General Description

The UM165xx series are VLDO (very low dropout) linear regulators designed for low power portable applications. Maximum dropout is just 90mV at the load current of 150mA. The internal P-channel MOSFET pass transistor requires no base current, allowing the device to draw only 100µA during normal operation at the maximum load current of 300mA.

Other features include high output voltage accuracy, excellent transient response, under voltage lockout, stability with ultralow ESR ceramic capacitors as small as 1µF, reverse-battery protection, short-circuit and thermal overload protection and output current limiting.

The UM165xx series are available in a low profile SOT23-3 package.

Applications

- Bluetooth/802.11 Cards
- PDAs and Notebook Computers
- Portable Instruments and Battery-Powered Systems
- Cellular Phones

Features

- Very Low Dropout: 90mV (Max) at 150mA
- Maximum Input Voltage: 6.0V
- ±2% Voltage Accuracy at 150mA
- Fast Transient Response
- Under Voltage Lockout
- Fixed Output Voltage: 3.3V/2.8V
- Output Current Limit
- Reverse-Battery Protection
- No Protection Diodes Needed
- Stable with 1µF Output Capacitor
- Short-Circuit and Thermal Overload Protection
- Low Profile SOT23-3 Package

Pin Configurations

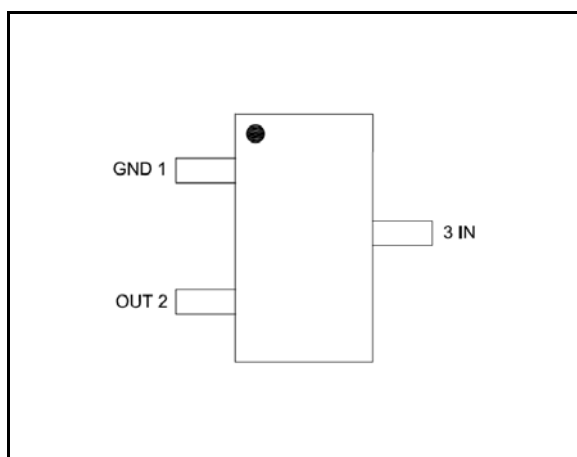

Top View

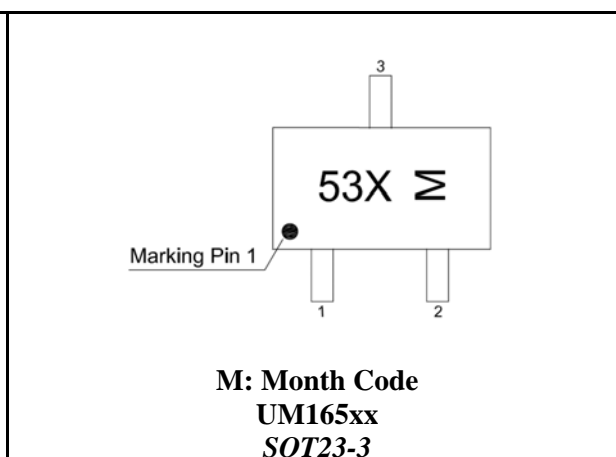

Ordering Information

Part Number	Output Voltage	Packaging Type	Marking Code	Shipping Qty
UM16528	2.8V	SOT23-3	53Q	3000pcs/7Inch Tape & Reel
UM16533	3.3V		53U	

Pin Description

Pin Number	Symbol	Function
1	GND	Ground
2	OUT	Voltage Regulated Output
3	IN	Power Supply

Absolute Maximum Ratings (Note 1)

Symbol	Parameter	Value	Unit
V _{IN}	Supply Voltage on IN Pin	-7.5 to +7.5	V
V _{OUT}	Voltage on OUT Pin	-0.3 to +7.5	V
	Output Short-Circuit Duration	Indefinite	
T _J	Operating Junction Temperature (Note 2, 3)	-40 to +125	°C
T _{STG}	Storage Temperature Range	-65 to +150	°C
T _L	Lead Temperature for Soldering 10 Seconds	+300	°C

Note 1: Absolute Maximum Ratings are those values beyond which the life of a device may be impaired.

Note 2: The UM165xx is tested and specified under pulse load conditions such that $T_J \approx T_A$. The device is guaranteed to meet performance specifications from 0°C to 70°C. Specifications over the -40°C to 125°C operating junction temperature range are assured by design, characterization and correlation with statistical process controls.

Note 3: This IC includes overtemperature protection that is intended to protect the device during momentary overload conditions. Junction temperature will exceed 125°C when overtemperature protection is active. Continuous operation above the specified maximum operating junction temperature may impair device reliability.

Electrical Characteristics

Symbol	Parameter	Test Conditions	Min	Typ	Max	Unit	
V_{IN}	Input Voltage Range		$V_{OUT}+$ V_{DROP}		6.0	V	
V_{UVLO1} (Note 1)	Input Under Voltage Lockout	V_{IN} Falling	2.0		2.6	V	
V_{UVLO2} (Note 2)	Input Under Voltage Lockout	V_{IN} Falling	2.1		2.3	V	
I_Q	Operating Quiescent Current	$I_{OUT}=0mA$		90		μA	
		$I_{OUT}=300mA$		100			
	ESD Rating	Human Body Mode	2			kV	
I_{OUT}	Output Current		300			mA	
	Output Voltage Accuracy	$1mA \leq I_{OUT} \leq 150mA$, $T_A = +25^\circ C$	-1		+1	%	
		$1mA \leq I_{OUT} \leq 150mA$, $T_A = -40^\circ C$ to $+85^\circ C$	-2		+2		
		$1mA \leq I_{OUT} \leq 300mA$, $T_A = -40^\circ C$ to $+85^\circ C$	-2.5		+2.5		
ΔV_{DO}	Dropout Voltage	$I_{OUT}=150mA$			90	mV	
I_{LIMIT}	Output Current Limit	$V_{IN} \geq 2.5V$	450			mA	
	Input Reverse Leakage Current (OUT to IN Leakage Current)	$V_{IN}=4V$, $V_{OUT}=5.5V$ Chip Active		0.01	1.5	μA	
T_{SHDN}	Thermal-Shutdown Temperature			160		$^\circ C$	
ΔT_{SHDN}	Thermal-Shutdown Hysteresis			20		$^\circ C$	
	Line Regulation	$V_{OUT}+1V \leq V_{IN} \leq V_{OUT}+2V$ $I_{OUT}=10mA$		0.09		%/V	
	Load Regulation	$V_{IN}=V_{OUT}+1V$ $1mA \leq I_{OUT} \leq 150mA$		0.2		%	
PSRR	Power Supply Ripple Rejection	$V_{IN}=V_{OUT}+1V$ $I_{OUT}=100mA$	$f=100Hz$		70		dB
			$f=1kHz$		65		
			$f=10kHz$		50		
			$f=100kHz$		40		

Note 1: V_{UVLO1} is measured for devices with $V_{OUT} \geq 1.8V$.

Note 2: V_{UVLO2} is measured for devices with $V_{OUT} \leq 1.5V$.

Note 3: ΔV_{DO} just define for device with $V_{OUT} \geq 2.5V$.

Pin Function

GND (Pin1): Ground and Heat Sink. Solder to a ground plane or large pad to maximize heat dissipation.

OUT (Pin 2): Voltage Regulated Output. The OUT pin supplies power to the load. A minimum output capacitor of 1 μ F is required to ensure stability. Larger output capacitors may be required for applications with large transient loads to limit peak voltage transients. See the Applications Information section for more information on output capacitance.

IN (Pin 3): Power for UM165xx and Load. Power is supplied to the devices through the IN pin. The IN pin should be locally bypassed to ground if the UM165xx series are more than a few inches away from another source of bulk capacitance. In general, the output impedance of a battery rises with frequency, so it is usually advisable to include an input bypass capacitor in battery-powered circuits. A capacitor in the range of 0.1 μ F to 1 μ F is usually sufficient. The UM165xx series are designed to withstand reverse voltages on the IN pin with respect to both ground and the output pin. In the case of a reversed input, which can happen if a battery is plugged in backwards, the UM165xx will act as if there is a large resistor in series with its input with only a small amount of current flow.

Typical Application Circuit

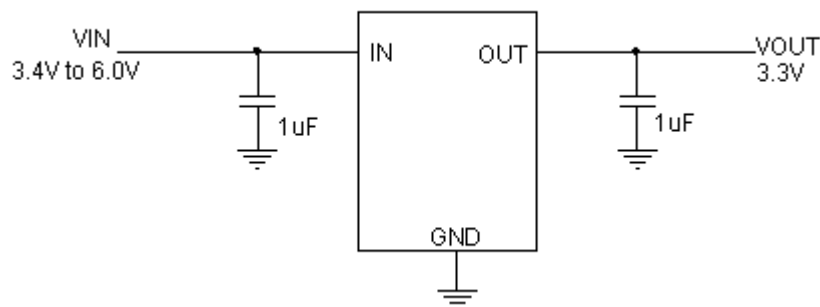

Typical Performance Characteristics

Quiescent Current vs. Input Voltage

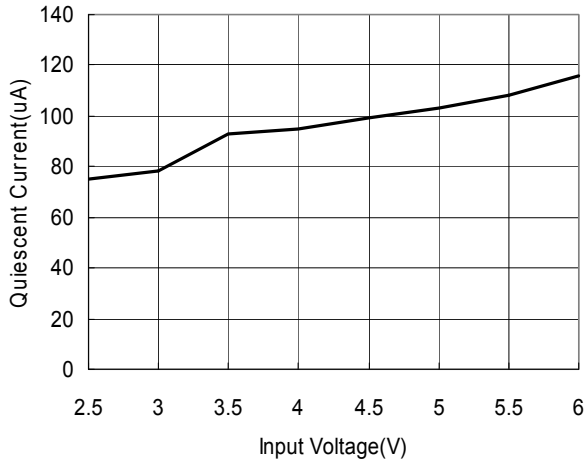

Output Voltage vs. Output Current

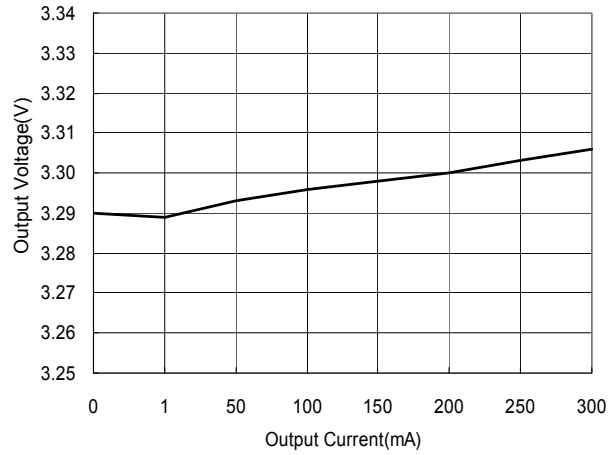

Dropout Voltage vs. Output Current

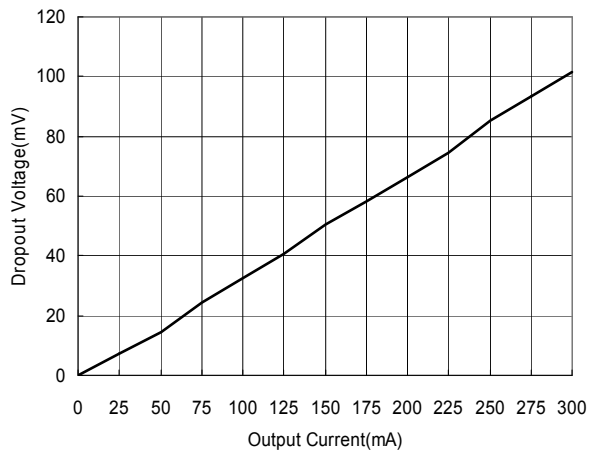

Line Transient Response

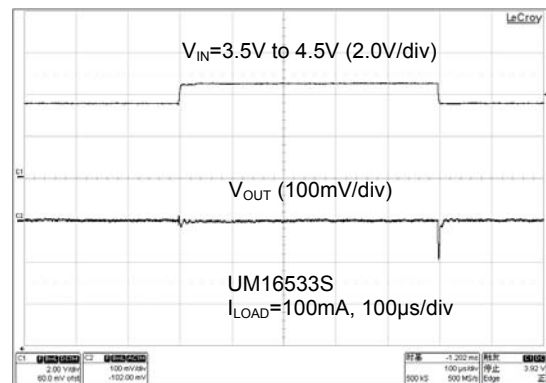

Load Transient Response

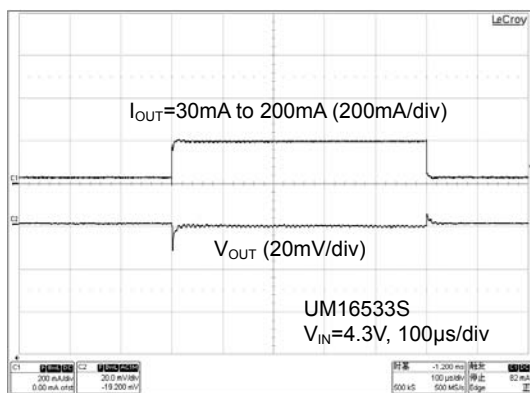

Package Information

UM165xx: SOT23-3

Outline Drawing

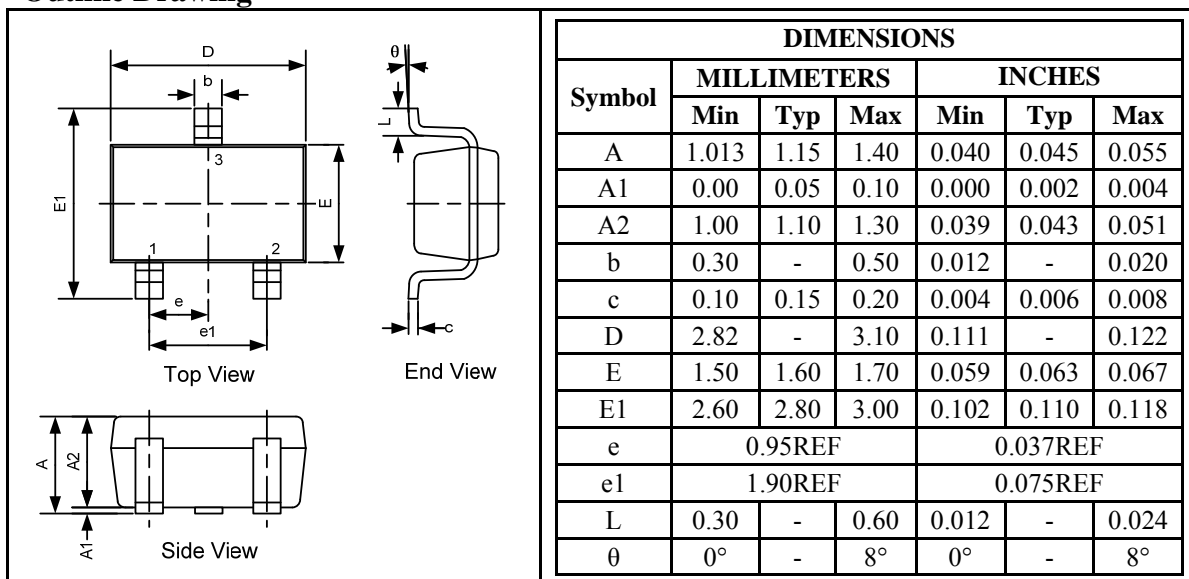

Land Pattern

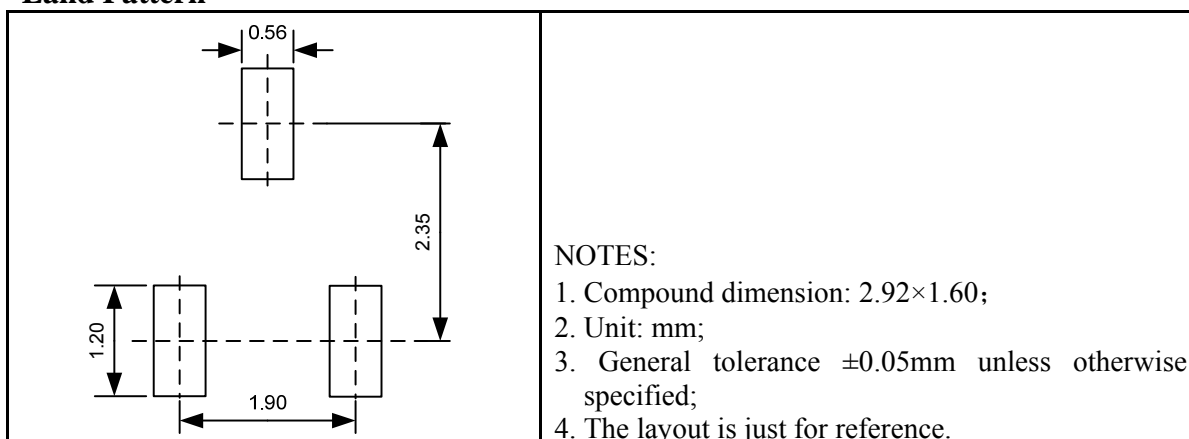

Tape and Reel Orientation



GREEN COMPLIANCE

Union Semiconductor is committed to environmental excellence in all aspects of its operations including meeting or exceeding regulatory requirements with respect to the use of hazardous substances. Numerous successful programs have been implemented to reduce the use of hazardous substances and/or emissions.

All Union components are compliant with the RoHS directive, which helps to support customers in their compliance with environmental directives. For more green compliance information, please visit:

http://www.union-ic.com/index.aspx?cat_code=RoHSDeclaration

IMPORTANT NOTICE

The information in this document has been carefully reviewed and is believed to be accurate. Nonetheless, this document is subject to change without notice. Union assumes no responsibility for any inaccuracies that may be contained in this document, and makes no commitment to update or to keep current the contained information, or to notify a person or organization of any update. Union reserves the right to make changes, at any time, in order to improve reliability, function or design and to attempt to supply the best product possible.



Union Semiconductor, Inc

Add: Unit 606, No.570 Shengxia Road, Shanghai 201210

Tel: 021-51093966

Fax: 021-51026018

Website: www.union-ic.com