

UM202E/232E

High ESD-Protected, Fail-Safe, Single Supply RS-232 Transceivers

General Description

The UM202E/232E series are low power single supply RS232 interface. The device consists of two line drivers, two line receivers, and a dual charge pump circuit. The device meets the requirements of TIA/EIA-232 standard and provides the electrical interface between an asynchronous communication controller and the serial-port connector.

The on chip charge pump and four small external capacitors act as onboard DC to DC converter, allow chip operated from single 5V supply, eliminating the need for +/- 10V power supplies, reduce cost and board space. Chip power supply current is specified at 6.0 mA maximum, making the device ideal for battery and power conscious applications.

The device operates at data signaling rates over 120 Kb/s. The slew rate of driver is set internally less than 30V/ μ s and the receivers feature internal noise filtering, eliminating the need for external slew rate and filter capacitors for reliable operation. The driver inputs and receiver outputs are TTL and CMOS compatible.

UM202E/232E comes in 16 pin DIP, SOP and SSOP packages, operating over the commercial and industrial temperature ranges.

The ESD tolerance has been upgraded on these devices to over +/- 15KV for both Human Body Model and IEC1000-4-2 Air Discharge Method, without latchup. These devices are pin-to-pin compatible with MAX202/232 devices as well as other popular industry standards.

Applications

Notebook, Subnotebook
Palmtop Computers
Battery-Powered Equipment
Hand-Held Equipment
POS terminal
Network Communication Equipment

Features

ESD Protection for RS-232 Bus Pins up to +/- 15kV Human Body Model
Meets or Exceeds the Requirements of TIA/EIA-232-F and ITU V.28 Standards
Single +5V power supply
Low power, I_{CC} 6.0 mA maximum
Operates up to 120 Kbit/s
BiCMOS Technology
Receiver Noise Filter
Latch-Up Performance Exceeds 200 mA
Pin compatible with industry standard MAX232, ICL232

Ordering Information

PART	TEMP. RANGE	PIN PACKAGE
UM202ECSE	0 °C to +70 °C	16 SO
UM202ECPE	0 °C to +70 °C	16 Plastic DIP
UM202EESE	-40 °C to +85 °C	16 SO
UM202EEPE	-40 °C to +85 °C	16 Plastic DIP
UM232ECSE	0 °C to +70 °C	16 SO
UM232ECPE	0 °C to +70 °C	16 Plastic DIP
UM232EESE	-40 °C to +85 °C	16 SO
UM232EEPE	-40 °C to +85 °C	16 Plastic DIP
UM202EE/D	-40 °C to +85 °C	Die Form
UM232EE/D	-40 °C to +85 °C	Die Form

Absolute Maximum Ratings

V _{CC}	-0.3V to +6V	Short-Circuit Duration, T_OUT.....	Continuous
V ₊	(V _{CC} - 0.3V) to +14V	Continuous Power Dissipation (TA = +70°C)	
V ₋	-14V to +0.3V	16-Pin Plastic DIP (derate 10.53mW/°C above +70°C)...	842mW
Input Voltages		16-Pin Narrow SO (derate 8.70mW/°C above +70°C).....	696mW
T_IN	-0.3V to (V ₊ + 0.3V)	Operating Temperature Ranges	
R_IN	+/-30V	UM202EC__	0°C to +70°C
Output Voltages		UM202EE__	-40°C to +85°C
T_OUT.....	(V ₋ - 0.3V) to (V ₊ + 0.3V)	Storage Temperature Range.....	-65°C to +165°C
R_OUT.....	-0.3V to (V _{CC} + 0.3V)	Lead Temperature (soldering, 10sec)	+300°C

Stresses beyond those listed under Absolute Maximum Ratings may cause permanent damage to the device. These are stress ratings only, and functional operation of the device at these or any other conditions beyond those indicated in the operational sections of the specifications is not implied. Exposure to absolute maximum rating conditions for extended periods may affect device reliability.

Pin Description

Pin	Name	Function
DIP/SO/SSOP		
1,3	C1 ₊ , C1 ₋	Terminals for positive charge-pump capacitor
2	V ₊	+2V _{CC} voltage generated by the charge pump
4,5	C2 ₊ , C2 ₋	Terminals for negative charge-pump capacitor
6	V ₋	-2V _{CC} voltage generated by the charge pump
7,14	T_OUT	RS-232 Driver Outputs
8,13	R_IN	RS-232 Receiver Outputs
9,12	R_OUT	RS-232 Receiver Outputs
10,11	T_IN	RS-232 Driver Inputs
15	GND	Ground
16	V _{CC}	+4.5V to +5.5V Supply-Voltage Input

ELECTRICAL CHARACTERISTICS

($V_{CC} = +5V \pm 10\%$ for UM202/232; $C1-C4 = 0.1\mu F$ for UM202/232; $C1 \sim C4 = 0.1\mu F$; $T_A = T_{MIN}$ to T_{MAX} ; unless otherwise noted. Typical values are at $T_A = +25^\circ C$.)

PARAMETER	SYMBOL	CONDITIONS	MIN	TYP	MAX	UNITS
DC CHARACTERISTICS						
V_{CC} Supply Current	I_{CC}	No load, $T_A = +25^\circ C$	UM202	3	8	mA
LOGIC						
Input Leakage Current		$T_{IN} = 0V$ to V_{CC}			± 10	μA
Input Threshold Low	V_{IL}	T_{IN}			0.8	V
Input Threshold High	V_{IH}	T_{IN}	2.0			V
Output Voltage Low	V_{OL}	R_{OUT} ; $I_{OUT} = 3.2mA$			0.4	V
Output Voltage High	V_{OH}	R_{OUT} ; $I_{OUT} = -1.0mA$	3.5	$V_{CC}-0.4$		V
EIA/TIA-232E RECEIVER INPUTS						
Input Voltage Range			-30		30	V
Input Threshold Low		$T_A = +25^\circ C$, $V_{CC} = 5V$ Normal operation	0.8	1.0		V
Input Threshold High		$T_A = +25^\circ C$, $V_{CC} = 5V$ Normal operation		2.0	2.4	V
Input Hysteresis		$V_{CC} = 5V$	0.1		0.2	V
Input Resistance		$T_A = +25^\circ C$, $V_{CC} = 5V$	3	5	7	k Ω
EIA/TIA-232E TRANSMITTER OUTPUTS						
Output Voltage Swing		All drivers loaded with $3k\Omega$ to ground (Note 1)	± 5	± 9		V
Output Resistance		$V_{CC} = V_+ = V_- = 0V$, $V_{OUT} = \pm 2V$	300			Ω
Output Short-Circuit Current				± 10	± 60	mA
TIMING CHARACTERISTICS						
Maximum Data Rate		$R_L = 3k\Omega$ to $7k\Omega$, $C_L = 50pF$ to $1000pF$, one transmitter switching	120			kbps
Receiver Propagation Delay	t_{PLHR} , t_{PHLR}	$C_L = 150pF$ All parts, normal operation		0.5	1	μs
Transmitter Propagation Delay	t_{PLHT} , t_{PHLT}	$R_L = 3k\Omega$, $C_L = 2500pF$, all transmitters loaded		1		μs
Transition-Region Slew Rate		$T_A = +25^\circ C$, $V_{CC} = 5V$, $R_L = 3k\Omega$ to $7k\Omega$, $C_L = 50pF$ to $1000pF$, measured from $-3V$ to $+3V$ or $+3V$ to $-3V$, Figure 1	3	6	30	V/ μs
ESD PERFORMANCE: TRANSMITTER OUTPUTS, RECEIVER INPUTS						
ESD-Protection Voltage		Human Body Model		± 15		kV
		IEC1000-4-2, Contact Discharge		± 8		
		IEC1000-4-2, Air-Gap Discharge		± 15		

Pin Assignment

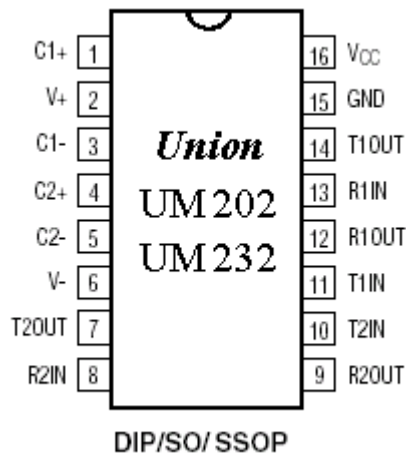

Typical Operating Characteristics

(Typical Operating Circuits, $V_{CC} = +5V$, $T_A = +25^\circ C$, unless otherwise noted.)

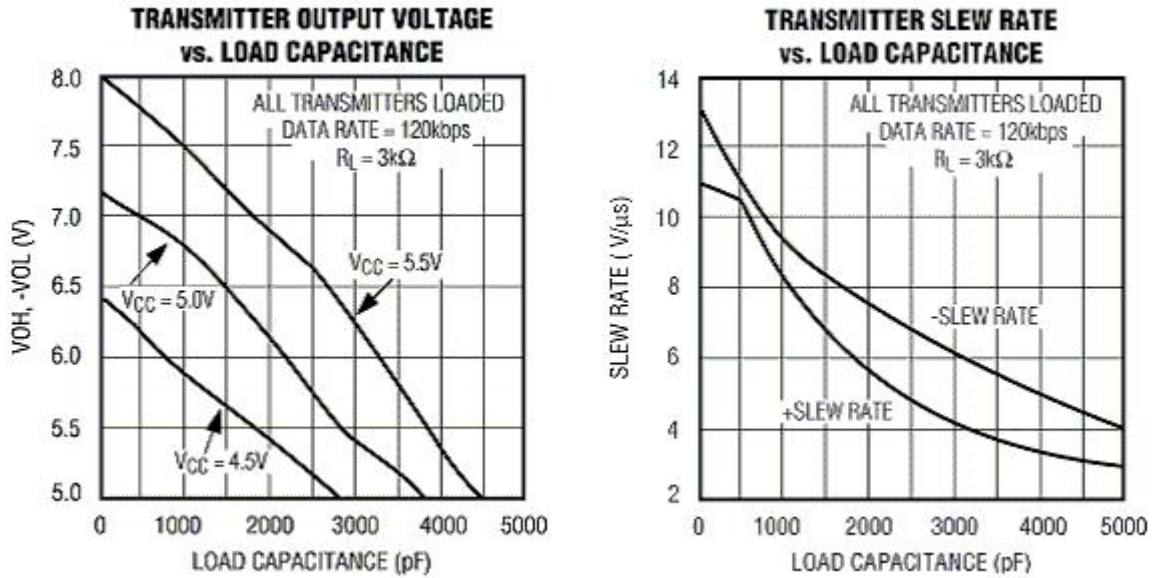

Test Circuits

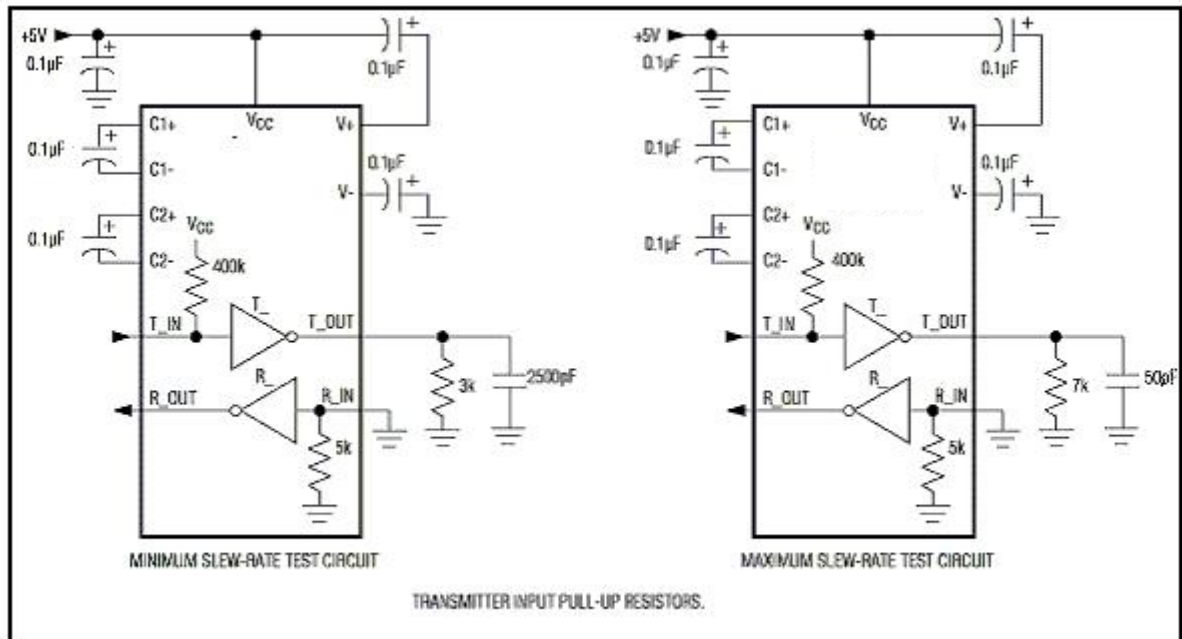

Figure 1. Transition Slew-Rate Circuit

Detailed Description

The UM202/232 consist of three sections: charge-pump voltage converters, drivers, and receivers. These E versions provide extra protection against ESD. They survive $\pm 15\text{kV}$ discharges to the RS-232 inputs and outputs, tested using the Human Body Model. When tested according to IEC1000-4-2, they survive $\pm 8\text{kV}$ contact-discharges and $\pm 15\text{kV}$ air-gap discharges. The rugged E versions are intended for use in harsh environments or applications where the RS-232 connection is frequently changed. The UM202E/232E devices have internal charge pump voltage converters which allow them to operate from a single +5V supply. The charge pumps will operate with polarized or non-polarized capacitors ranging from 0.1 to 10 micro F and will generate the $\pm 6\text{V}$ needed to generate the RS-232 output levels.

Capacitor Selection

The capacitor type used for C1-C4 is not critical for proper operation. The UM202 requires 0.1 micron F capacitors, although capacitors up to 10 micron F can be used without harm. Ceramic dielectrics are suggested for the 0.1micron F capacitors. When using the minimum recommended capacitor values, make sure the capacitance value does not degrade excessively as the operating temperature varies. If in doubt, use capacitors with a larger (e.g., 2X) nominal value. The effective series resistance (ESR) of capacitors, which usually rises at low temperatures, influences the amount of ripple on V+ and V-. Use larger capacitors (up to 10 X) to reduce the output impedance at V+ and V-. Bypass VCC to ground with at least 0.1 micron F. In applications sensitive to power-supply noise generated by the charge pumps, decouple VCC to ground with a capacitor the same size as (or larger than) the charge-pump capacitors (C1-C4).

RS-232 Drivers

The drivers are inverting transmitters, which accept TTL or CMOS inputs and output the RS-232 signals with an inverted sense relative to the input logic levels. Typically the RS-232 output voltage swing is 6V. Even under worst case loading conditions of 3kOhms and 2500pF, the output is guaranteed to be 5V, which is consistent with the RS-232 standard specifications. The transmitter outputs are protected against infinite short-circuits to ground without degradation in reliability. The instantaneous slew rate of the transmitter output is internally limited to a maximum of 30V/ μs in order to meet the standards [EIA RS-232-D 2.1.7, Paragraph (5)]. However, the transition region slew rate of these enhanced products is typically 10V/ μs . The smooth transition of the loaded output from VOL to VOH clearly meets the monotonicity requirements of the standard [EIA RS-232-D 2.1.7, Paragraphs (1) & (2)].

RS-232 Receivers

The receivers convert RS-232 input signals to inverted TTL signals. Since the input is usually from a transmission line, where long cable lengths and system interference can degrade the signal, the inputs have a typical hysteresis margin of 500mV. This ensures that the receiver is virtually immune to noisy transmission lines. The input thresholds are 0.8V minimum and 2.4V maximum, again well within the 3V RS-232 requirements. The receiver inputs are also protected against voltages up to 25V. Should an input be left unconnected, a 5KOhm pull down resistor to ground will commit the output of the receiver to a high state. In actual system applications, it is quite possible for signals to be applied to the receiver inputs before power is applied to the receiver circuitry. This occurs, for example, when a PC user attempts to print, only to realize the printer wasn't turned on. In this case an RS-232 signal from the PC will appear on the receiver input at the printer. When the printer power is turned on, the receiver will operate normally. All of these enhanced devices are fully protected.

ESD Protection

UM202/232 devices have standard ESD protection structures incorporated on the pins to protect against electrostatic discharges encountered during assembly and handling. In addition, the RS232 bus pins (driver outputs and receiver inputs) of these devices have an extra level of ESD protection. Advanced ESD structures were designed to successfully protect these bus pins against ESD discharge of 15 kV when powered down.