

Features

- Access time 250/350/450ns (max.)
- Single +5V ±10% power supply
- TTL compatible inputs and outputs
- Three-state outputs
- Pin compatible with 2532 EPROM
- Two programmable chip selects for output control
- N-channel silicon gate technology

General Description

The UM2332 is a 32,768-bit static MOS read only memory organized as 4096 words by 8 bits. The device is completely static in operation, and operates from a single +5V power supply. All inputs and outputs are TTL compatible. The two chip select inputs are programmable.

Programming of the device is accomplished by a custom masking process. The UM2332 is designed for memory applications where high performance, large bit storage, and simple interfacing are important design objectives.

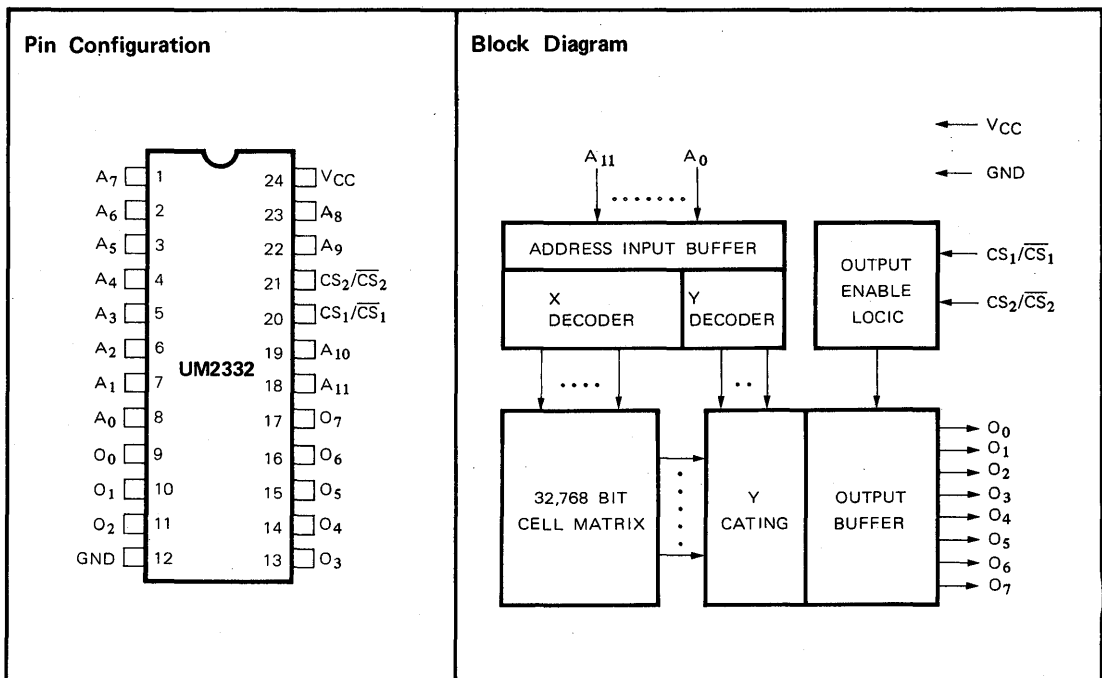

Absolute Maximum Ratings*

Ambient temperature under bias, T_A -10 to $+80^\circ\text{C}$
 Storage temperature, T_{STG} -65 to $+150^\circ\text{C}$
 Applied voltage on any pin with
 respect to ground -0.5 to $+7\text{V}$
 Power dissipation, P_D 1.0W

***Comments**

Stresses above those listed under "Absolute Maximum Ratings" may cause permanent damage to the device. These are stress ratings only. Functional operation of this device at these or any other conditions above those indicated in the operational sections of this specification is not implied and exposure to absolute maximum rating conditions for extended periods may affect device reliability.

D.C. Electrical Characteristics

($T_A = 0$ to 70°C , $V_{\text{CC}} = 5\text{V} \pm 10\%$ unless otherwise specified)

Symbol	Parameter	Limits			Units	Test Conditions
		Min.	Typ.	Max.		
V_{IL}	Input low voltage	-0.05		0.8	V	
V_{IH}	Input high voltage	2.0		V_{CC}	V	
V_{OL}	Output low voltage			0.4	V	$I_{\text{OL}} = 2.1\text{mA}$
V_{OH}	Output high voltage	2.4		V_{CC}	V	$I_{\text{OH}} = -400\mu\text{A}$
I_{LI}	Input load current			10	μA	$V_{\text{IN}} = V_{\text{CC}} = 5.25\text{V}$
I_{LO}	Output leakage current			10	μA	$V_{\text{OUT}} = V_{\text{CC}} = 5.25\text{V}$
I_{CC}	V_{CC} current			100	mA	

Capacitance

($T_A = 25^\circ\text{C}$ $f = 1.0\text{MHz}$)

Symbol	Parameter	Limits		Unit	Test Conditions
		Typ.	Max.		
C_{IN}	Input capacitance		7	pF	All pins except pin under tied to AC ground
C_{OUT}	Output capacitance		10	pF	

Note:

This parameter is periodically sampled and is not 100% tested.

A.C. Electrical Characteristics

 ($T_A = 0$ to 70°C , $V_{CC} = 5\text{V} \pm 10\%$)

Symbol	Parameter	UM2332		UM2332-1		UM2332-2		Unit
		Min.	Max.	Min.	Max.	Min.	Max.	
t_{ACC}	Address access time 1		450		350		250	ns
t_{CO}	Output enable delay from $CS_1/\overline{CS_1}$ or $CS_2/\overline{CS_2}$		150		120		120	ns
t_{DF}	Output disable delay from $CS_1/\overline{CS_1}$ or $CS_2/\overline{CS_2}$	0	100	0	100	0	100	ns
t_{OH}	Output hold from address change	10		10		10		ns

Mask ROM

Test Conditions

 Output load 1 TTL load and 100pF
 Input transition time 20ns

 Timing reference levels
 Input = 1.5V, Output = 0.8V and 2.0V

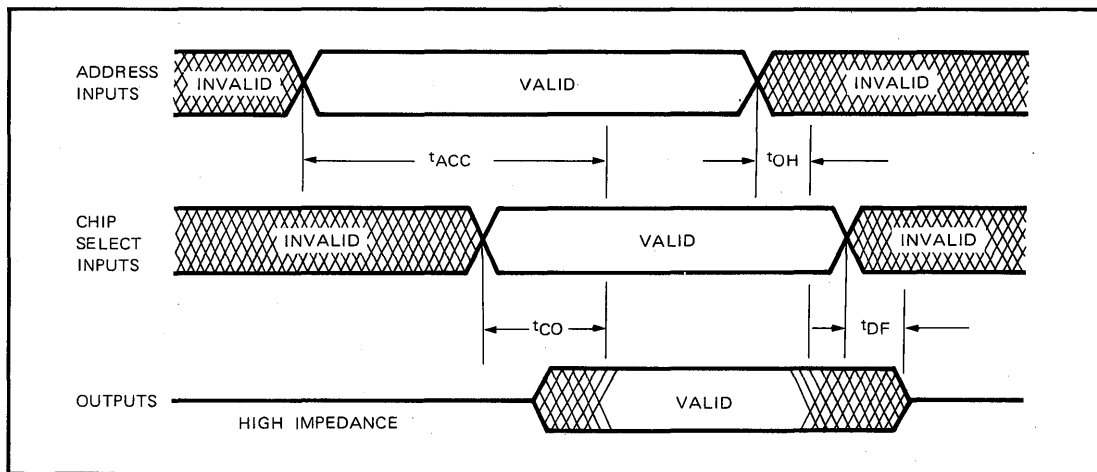
Timing Diagram

Ordering Information

Part Number	Access Time	Package
UM2332	450ns	Plastic
UM2332-1	350ns	Plastic
UM2332-2	250ns	Plastic