***±15kV ESD-Protected, Slew-Rate-Limited, Fail-Safe, True
RS-485 Transceivers with Integrated Low-Dropout Regulator
UM3090EESA SOP8-EP***

General Description

The UM3090EESA is ±15kV ESD-protected, high-speed transceiver for RS-485 communication that contains one internal low-dropout regulator, one driver and one receiver. The internal LDO allows the device to operate from an unregulated power supply of up to 30V.

The internal LDO generates a 5V±5% power supply that is used to power its internal circuitry. The UM3090EESA brings the 5V to an output V_{REG} that allows the user to power additional external circuitry with up to 20mA to further reduce external components. The device features fail-safe circuitry, which guarantees a logic-high receiver output when the receiver inputs are open, shorted or idle. This means that the receiver output will be logic high if all transmitters on a terminated bus are disabled (high impedance). The UM3090EESA features reduced slew-rate driver that minimizes EMI and reduces reflections caused by improperly terminated cables, allowing error-free data transmission up to 500kbps. The device also features enhanced ESD protection. All transmitter outputs and receiver inputs are protected to ±15kV for JESD22 the Human Body Model and IEC61000-4-2 Air-Gap Discharge Model, ±8kV for IEC61000-4-2 Contact Discharge Model.

The device has a 1/8-unit-load receiver input impedance that allows up to 256 transceivers on the bus and is intended for half-duplex communications. The UM3090EESA is available in an 8-pin SOP8-EP package with an exposed paddle to improve power dissipation, and operates over the extended -40°C to +85°C temperature range.

Applications

- Isolated RS-485 Interfaces
- Utility Meters
- Security and Protection
- Intelligent Sensors
- Industrial-Control Local Area Networks
- Transceivers for EMI-Sensitive Applications

Features

- +5.5V to +30V Wide Input Supply Range
- +5V Output Supplies Up to 20mA to External Circuitry
- Extended ESD Protection
 - ±15kV—Human Body Model
 - ±15kV—IEC61000-4-2, Air-Gap Discharge
 - ±8kV—IEC61000-4-2, Contact Discharge
- Enhanced Slew-Rate Limiting Facilitates Error-Free Data Transmission
- -7V to +12V Common-Mode Input Voltage Range
- Allows up to 256 Transceivers on the Bus
- Thermal Shutdown
- Current-Limiting for Driver Overload Protection

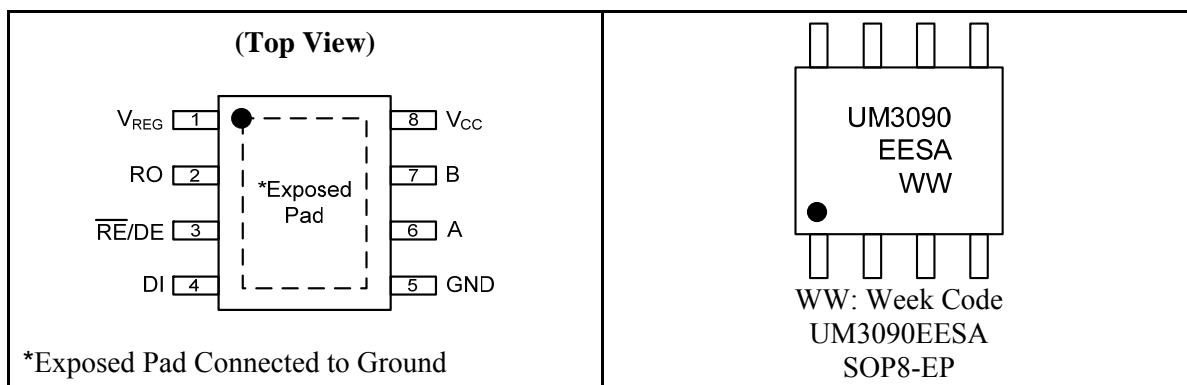
Pin Configurations
Top View

Ordering Information

Part Number	Operating Temperature	Marking Code	Packaging Type	Shipping Qty
UM3090EESA	-40°C to +85°C	UM3090EESA	SOP8-EP	2500pcs/13 Inch Tape and Reel

Selection Guide

Part Number	Guaranteed Data Rate (Mbps)	Slew-Rate Limited	Driver/Receiver Enable	Transceivers On Bus	±15kV ESD Protection
UM3090EESA	0.5	Yes	Yes	256	Yes

Absolute Maximum Ratings

Symbol	Parameter	Value	Unit
V _{CC}	Supply Voltage	-0.3 to +33	V
	Control Input Voltage (\overline{RE}/DE)	-0.3 to +5.3	V
	Driver Input Voltage (DI)	-0.3 to +5.3	V
	Driver Output Voltage (A, B)	-7.5 to +12.5	V
	Receiver Input Voltage (A, B)	-7.5 to +12.5	V
V _{REG}	Receiver Output Voltage (RO)	-0.3 to +5.3	V
	LDO Output Voltage	-0.3 to +5.3	V
	Short-Circuit Duration (RO, A, B) to GND	Continuous	
P _D	Continuous Power Dissipation (T _A =+25°C) (derate 10.2mW/°C above +25°C)	1410	mW
T _A	Ambient Temperature	-40 to +85	°C
T _{STG}	Storage Temperature Range	-65 to +160	°C
T _L	Lead Temperature for Soldering 10 seconds	+300	°C

DC Electrical Characteristics

($V_{CC}=+5.5V$ to $+30V$, $T_A=T_{MIN}$ to T_{MAX} , unless otherwise noted. Typical values are at $V_{CC}=+7.5V$, $C_S=10\mu F$ and $T_A=+25^\circ C$.) (Note 1)

Parameter	Symbol	Test Conditions	Min	Typ	Max	Unit
SUPPLY POWER						
Supply Voltage (Note 2)	V_{CC}	$I_{REG}+I_{AB}<50mA$	5.5		30	V
		$I_{REG}=20mA, I_{AB}=50mA$	5.5		25	
LDO Output Voltage	V_{REG}	$V_{CC}=+7.5\sim 30V,$ $I_{LOAD}=0\sim 20mA$	4.75	5.00	5.25	V
LDO Output Current	I_{REG}				20	mA
LDO Dropout Voltage	V_{DO}	$V_{CC}=+5V, I_{OUT}=20mA$		250	350	mV
Minimum Bypass Capacitor on V_{REG}	C_S	Guaranteed by Design	2.2	10		μF
Supply Current	I_{CC}	RE/DE=High, DI=Low, A B V_{REG} No Load		0.5	1	mA
LOGIC						
Input High Voltage	V_{IH}	DI, $\overline{RE/DE}$	2.0			V
Input Low Voltage	V_{IL}	DI, $\overline{RE/DE}$			0.8	V
Input Current	I_{IN}	DI, $\overline{RE/DE}$			4	μA
Receiver Output High Voltage	V_{OH}	$I_O=-1mA, V_A-V_B\geq V_{TH}$	$V_{REG}-1.5$			V
Receiver Output Low Voltage	V_{OL}	$I_O=+1mA, V_A-V_B\leq -V_{TH}$			0.4	V
Three-State Output Current at Receiver	I_{OZR}	$0V\leq V_O\leq V_{REG}$			± 1	μA
DRIVER						
Differential Driver Output	V_{OD}	$R_{DIFF}=100\Omega$, Figure 1	2			V
		$R_{DIFF}=54\Omega$, Figure 1	1.5			
		No Load			V_{REG}	
Change-in-Magnitude of Differential Output Voltage	ΔV_{OD}	$R_{DIFF}=100\Omega$ or 54Ω , Figure 1			0.2	V
Driver Common-Mode Output Voltage	V_{OC}	$R_{DIFF}=100\Omega$ or 54Ω , Figure 1	1.0		3.0	V
Change-in-Magnitude of Common-Mode Voltage	ΔV_{OC}	$R_{DIFF}=100\Omega$ or 54Ω , Figure 1			0.2	V
Driver Short-Circuit Output Current	I_{OSD}	$0V\leq V_{OUT}\leq +12V$		250		mA
		$-7V\leq V_{OUT}\leq 0V$		-250		

DC Electrical Characteristics (Continued)

($V_{CC}=+5.5V$ to $+30V$, $T_A=T_{MIN}$ to T_{MAX} , unless otherwise noted. Typical values are at $V_{CC}=+7.5V$, $C_S=10\mu F$ and $T_A=+25^\circ C$.) (Note 1)

Parameter	Symbol	Test Conditions	Min	Typ	Max	Unit
RECEIVER						
Receiver Differential Threshold Voltage	V_{TH}	$-7V \leq V_{CM} \leq 12V$	-200		-50	mV
Receiver Input Hysteresis	ΔV_{TH}	$V_A + V_B = 0V$		25		mV
Receiver Input Resistance	R_{IN}	$-7V \leq V_{CM} \leq 12V$	96			k Ω
Input Current (A and B)	$I_{A, B}$	$\overline{RE}/DE=GND$, $V_{CC}=GND$, $V_{IN}=+12V$			1.0	μA
		$V_{IN}=-7V$			-0.8	
Receiver Output Short Circuit Current	I_{OSR}	$0V \leq V_{RO} \leq V_{REG}$	± 8		± 60	mA
PROTECTION						
ESD Protection for A, B		Human Body Model		± 15		kV
		IEC61000-4-2 Air Discharge		± 15		
		IEC61000-4-2 Contact		± 8		
Thermal-Shutdown Threshold	T_{TS}			150		$^\circ C$
Thermal-Shutdown Threshold Hysteresis	T_{TSH}			15		$^\circ C$

Note 1: All currents into the device are positive; all currents out of the device are negative. All voltages are referred to device ground unless otherwise noted.

The C_S is the decoupling capacitor for V_{REG} , see the Typical Application Circuit

Note 2: If the $V_{CC} > 25V$, I_{REG} and I_{AB} must be satisfied by P_D condition

Switching Characteristics

($V_{CC}=+5.5V$ to $+30V$, $T_A=T_{MIN}$ to T_{MAX} , unless otherwise noted. Typical values are at $V_{CC}=+7.5V$, $C_S=10\mu F$ and $T_A=+25^\circ C$.) (Note 1)

Parameter	Symbol	Test Conditions	Min	Typ	Max	Unit
DRIVER						
Maximum Data Rate	f_{MAX}			500		kbps
Driver Input-to-Output	t_{DPLH}	Figure 2 and 6, $R_{DIFF}=54\Omega$, $C_L=50pF$	250	720	1000	ns
	t_{DPHL}		250	720	1000	
Driver Differential Output Rise or Fall Time	t_{HL}	Figure 2 and 6, $R_{DIFF}=54\Omega$, $C_L=50pF$	200	530	750	ns
	t_{LH}		200	530	750	
Driver Differential Output Skew $ t_{DPLH}-t_{DPHL} $	t_{DSKEW}	Figure 2 and 6, $R_{DIFF}=54\Omega$, $C_L=50pF$		3	100	ns
Driver Enable to Output High	t_{DZH}	Figure 3 and 7, $R_L=500\Omega$, $C_L=100pF$, S2 Closed			2500	ns
Driver Enable to Output Low	t_{DZL}	Figure 3 and 7, $R_L=500\Omega$, $C_L=100pF$, S1 Closed			2500	ns
Driver Disable Time from High	t_{DHZ}	Figure 3 and 7, $R_L=500\Omega$, $C_L=100pF$, S2 Closed			100	ns
Driver Disable Time from Low	t_{DLZ}	Figure 3 and 7, $R_L=500\Omega$, $C_L=100pF$, S1 Closed			100	ns
RECEIVER						
Maximum Data Rate	f_{MAX}			500		kbps
Receiver Input to Output	t_{RPLH} , t_{RPHL}	$C_L=15pF$ (at RO), Figure 5 and 8		127	200	ns
Receiver Output Skew $ t_{RPHL}-t_{RPLH} $	t_{RSKEW}	$C_L=15pF$ (at RO), Figure 5 and 8		3	30	ns
Receiver Enable to Output High	t_{RZH}	Figure 4 and 9, $C_L=15pF$, S2 Closed		20	50	ns
Receiver Enable to Output Low	t_{RZL}	Figure 4 and 9, $C_L=15pF$, S1 Closed		20	50	ns
Receiver Disable Time from High	t_{RHZ}	Figure 4 and 9, $C_L=15pF$, S2 Closed		20	50	ns
Receiver Disable Time from Low	t_{RLZ}	Figure 4 and 9, $C_L=15pF$, S1 Closed		20	50	ns

Pin Description

Pin Number	Symbol	Function
1	V _{REG}	LDO Output. V _{REG} is fixed at +5V. Bypass V _{REG} with a low ESR and a 2.2μF (min) ceramic capacitor.
2	RO	Receiver Output. If A>B by -50mV, RO will be high; if A<B by 200mV, RO will be low. Note: RO is referenced to the LDO output (V _{REG}).
3	$\overline{\text{RE/DE}}$	Receiver and Driver Output Enable. Drive $\overline{\text{RE/DE}}$ low to enable RO and disable the driver. Drive $\overline{\text{RE/DE}}$ high to disable RO and enable the driver.
4	DI	Driver Input. A low on DI forces output A low and output B high. Similarly, a high on DI forces output A high and output B low.
5	GND	Ground.
6	A	Non-Inverting Receiver Input and Non-Inverting Driver Output.
7	B	Inverting Receiver Input and Inverting Driver Output.
8	V _{CC}	Power Supply. Bypass V _{CC} with a 1μF capacitor to GND.
-	Exposed Pad	Exposed Pad is internally connected to GND. For enhanced thermal dissipation, connect Exposed Pad to a copper area as large as possible. Do not use Exposed Pad as a sole ground connection.

RS-485 Communication Function Table
Table 1. Transmitting

INPUTS		OUTPUTS	
$\overline{\text{RE/DE}}$	DI	B	A
0	X	High-Z	High-Z
1	1	0	1
1	0	1	0

X=Don't care; High-Z=High Impedance

Table 2. Receiving

INPUTS		OUTPUTS
$\overline{\text{RE/DE}}$	A-B	RO
0	≥-50mV	1
0	≤-200mV	0
0	Open/Short	1
1	X	High-Z

X=Don't care; High-Z=High Impedance

Functional Diagram

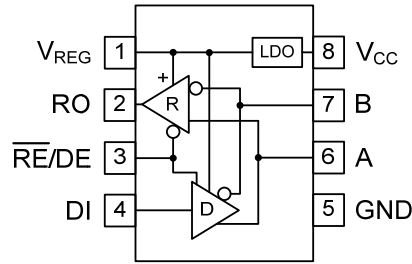

Test Circuit

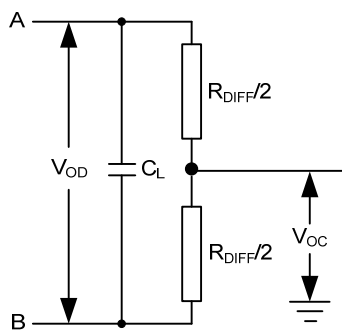

Figure 1. Driver DC Test Circuit

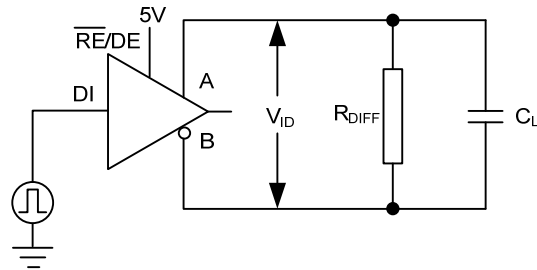

Figure 2. Driver Timing Test Circuit

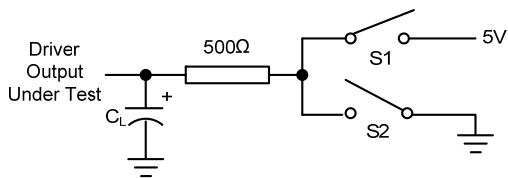

Figure 3. Driver Enable/Disable Timing Test Circuit

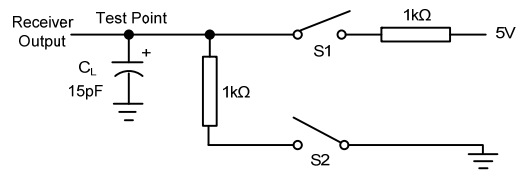

Figure 4. Receiver Enable/Disable Timing Test Circuit

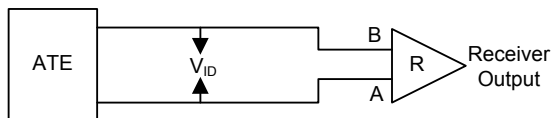

Figure 5. Receiver Propagation Delay Test Circuit

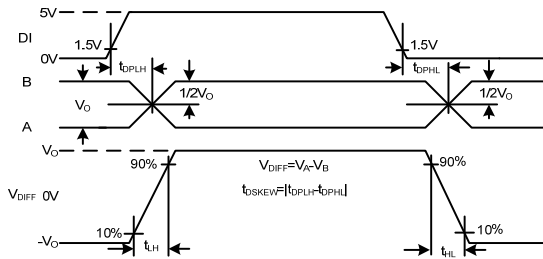

Figure 6. Driver Propagation Delays

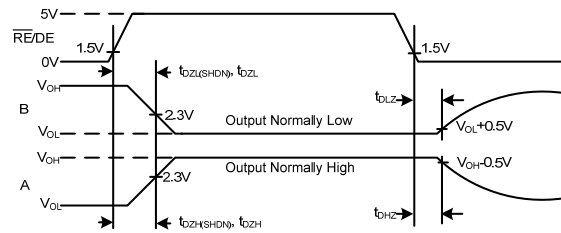

Figure 7. Driver Enable and Disable Times

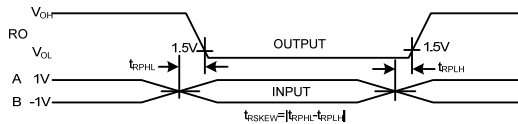

Figure 8. Receiver Propagation Delays

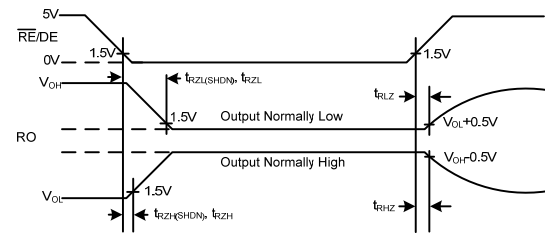
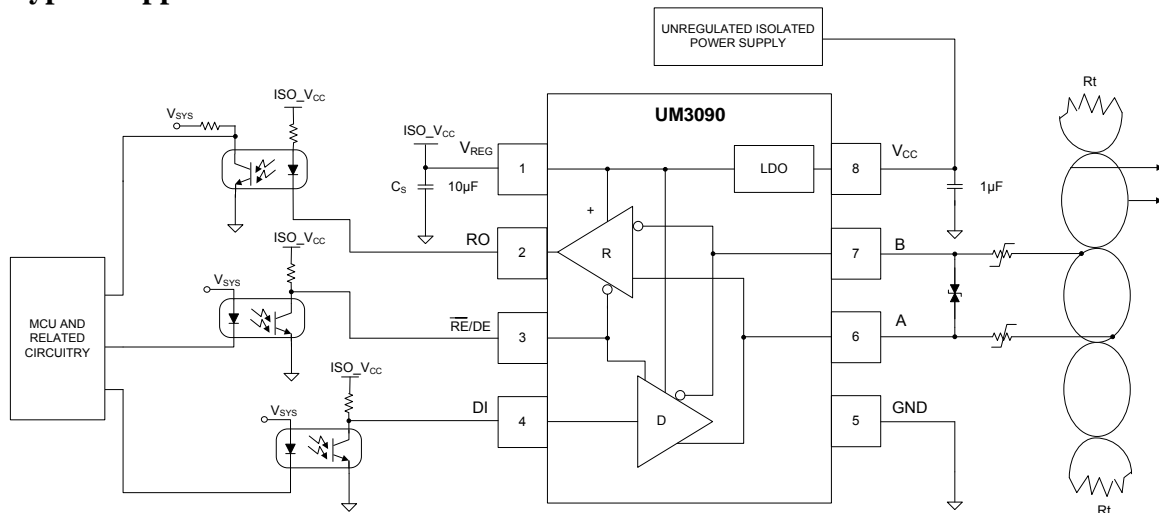

Figure 9. Receiver Enable and Disable Times

Typical Application Circuit



Detail Description

The UM3090EESA high-speed transceiver for RS-485 communication contains an internal LDO regulator, one driver and one receiver. The internal LDO allows the part to operate from an unregulated +5.5V to +30V power supply. The UM3090EESA's internal LDO generates a $5V \pm 5\%$ power supply that is used to power its internal circuitry. The UM3090EESA brings the 5V to an output V_{REG} that allows the user to power additional external circuitry with up to 20mA to further reduce external components. The device features fail-safe circuitry, which guarantees a logic-high receiver output when the receiver inputs are open or shorted, or when they are connected to a terminated transmission line with all drivers disabled. The UM3090EESA features reduced slew-rate driver that minimizes EMI and reduces reflections caused by improperly terminated cables, allowing error-free data transmission up to 500kbps.

The UM3090EESA drivers are output short-circuit current limited. Thermal shutdown circuitry protects device against excessive power dissipation. When activated, the thermal shutdown circuitry places the driver outputs into a high impedance state.

Internal Low-Dropout Regulator

The UM3090EESA includes an internal low-dropout regulator that allows it to operate from input voltages of up to +30V. The internal LDO has a set output voltage of $5V \pm 10\%$ that is used to power the internal circuitry of the device. The UM3090EESA offers the LDO output at the V_{REG} output. This allows additional external circuitry to be powered without the need for additional external regulators. The V_{REG} output can source up to 20mA.

When using the device with high input voltages and heavily loaded networks, special care must be taken that the power dissipation rating of the package and the maximum die temperature of the device is not exceeded.

The absolute maximum rating of the die temperature of the UM3090EESA is +150°C. To protect the part from overheating, there is an internal thermal shutdown that shuts down the part when the die temperature reaches +150°C. To prevent damage to the part, and to prevent the part from entering thermal shutdown, keep the die temperature below +150°C, plus some margin.

Fail-Safe

The UM3090EESA guarantees a logic-high receiver output when the receiver inputs are shorted or open, or when they are connected to a terminated transmission line with all drivers disabled. This is done by setting the receiver input threshold between -50mV and -200mV. If the differential receiver input voltage (A-B) is greater than or equal to -50mV, RO is logic high. If (A-B) is less than or equal to -200mV, RO is logic low. In the case of a terminated bus with all transmitters disabled, the receiver's differential input voltage is pulled to 0V by the termination. With the receiver thresholds of the UM3090EESA, this result is a logic-high with a 50mV minimum noise margin. Unlike previous fail-safe devices, the -50mV to -200mV threshold complies with the $\pm 200\text{mV}$ EIA/TIA-485 standard.

$\pm 15\text{kV}$ ESD Protection

As with all Union devices, ESD-protection structures are incorporated on all pins to protect against electrostatic discharges encountered during handling and assembly. The driver outputs and receiver inputs of the UM3090EESA have extra protection against static electricity. Union's engineers have developed state-of-the-art structures to protect these pins against ESD of $\pm 15\text{kV}$ without damage. The ESD-protected pins are tested with reference to the ground pin in a powered-down condition. They are tested to $\pm 15\text{kV}$ using the Human Body Model.

Applications Information

Typical Applications

The UM3090EESA transceiver is designed for bidirectional data communications on multipoint bus transmission lines. To minimize reflections, the line should be terminated at both ends in its characteristic impedance, and stub lengths off the main line should be kept as short as possible.

256 Transceivers on the Bus

The standard RS-485 receiver input impedance is $12\text{k}\Omega$ (one unit load), and the standard driver can drive up to 32 unit loads. The Union family of transceivers have a 1/8 unit load receiver input

impedance (96kΩ), allowing up to 256 transceivers to be connected in parallel on one communication line. Any combination of these devices and/or other RS-485 transceivers with a total of 32 unit loads or less can be connected to the line.

Reduced EMI and Reflections

The UM3090EESA is slew-rate limited, minimizing EMI and reducing reflections caused by improperly terminated cables. In general, a transmitter's rise time relates directly to the length of an unterminated stub, which can be driven with only minor waveform reflections. The following equation expresses this relationship conservatively:

$$\text{Length} = t_{\text{RISE}} / (10 \times 1.5 \text{ ns/ft})$$

Where t_{RISE} is the transmitter's rise time.

A system can work well with longer unterminated stubs, even with severe reflections, if the waveform settles out before the UART samples them.

Driver Output Protection

Two mechanisms prevent excessive output current and power dissipation caused by faults or by bus contention. The first, a foldback current limit on the output stage, provides immediate protection against short circuits over the whole common-mode voltage range. The second, a thermal shutdown circuit, forces the driver outputs into a high-impedance state if the die temperature becomes excessive.

Line Length vs. Data Rate

The RS-485/RS-422 standard covers line lengths up to 4000 feet. For line lengths greater than 4000 feet, repeater is required.

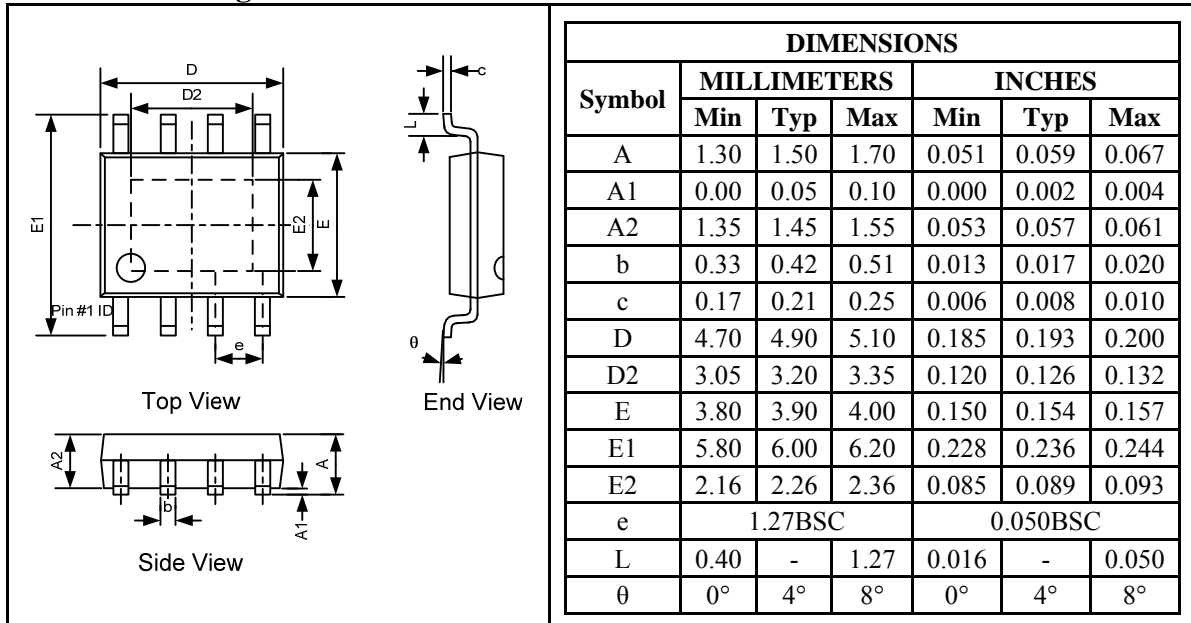
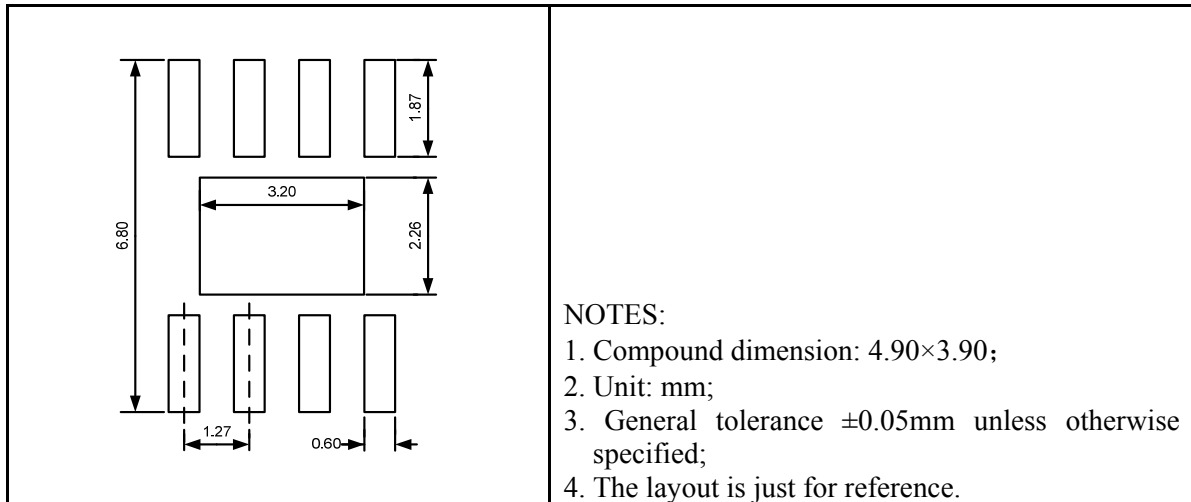
Package Information
SOP8-EP
Outline Drawing

Land Pattern

Tape and Reel Orientation

GREEN COMPLIANCE

Union Semiconductor is committed to environmental excellence in all aspects of its operations including meeting or exceeding regulatory requirements with respect to the use of hazardous substances. Numerous successful programs have been implemented to reduce the use of hazardous substances and/or emissions.

All Union components are compliant with the RoHS directive, which helps to support customers in their compliance with environmental directives. For more green compliance information, please visit:

http://www.union-ic.com/index.aspx?cat_code=RoHSDeclaration

IMPORTANT NOTICE

The information in this document has been carefully reviewed and is believed to be accurate. Nonetheless, this document is subject to change without notice. Union assumes no responsibility for any inaccuracies that may be contained in this document, and makes no commitment to update or to keep current the contained information, or to notify a person or organization of any update. Union reserves the right to make changes, at any time, in order to improve reliability, function or design and to attempt to supply the best product possible.



Union Semiconductor, Inc

Add: Unit 606, No.570 Shengxia Road, Shanghai 201210

Tel: 021-51093966

Fax: 021-51026018

Website: www.union-ic.com