

3 1/2 -Digit Multiplexed LCD Alarm Clock

Features

- 3 1/2-digit 2-function clock in hour and minute
- Alarm clock in hour and minute
- Snooze function
- Direct 1/2-duty multiplexed LCD drive capability
- Single 1.5V battery operation
- Voltage doubler
- Alarm sound demonstration capability
- 7 switches (with pull-down resistors)
- Low power dissipation
- 32.768KHz crystal controlled operation
- Push-pull driving buffer for buzzer
- Special trigger output for switch control
- Power-on reset
- Colon flash or freeze by mask option

General Description

UM3273 is a low threshold voltage, metal-gate CMOS IC that provides all signals needed to drive a 1/2-duty multiplexed LCD clock of 3 1/2 digits.

The circuit time base is a 32.768KHz crystal controlled oscillator, oscillator RC network components are included in the circuit, the UM3273 operates on a single 1.5V battery.

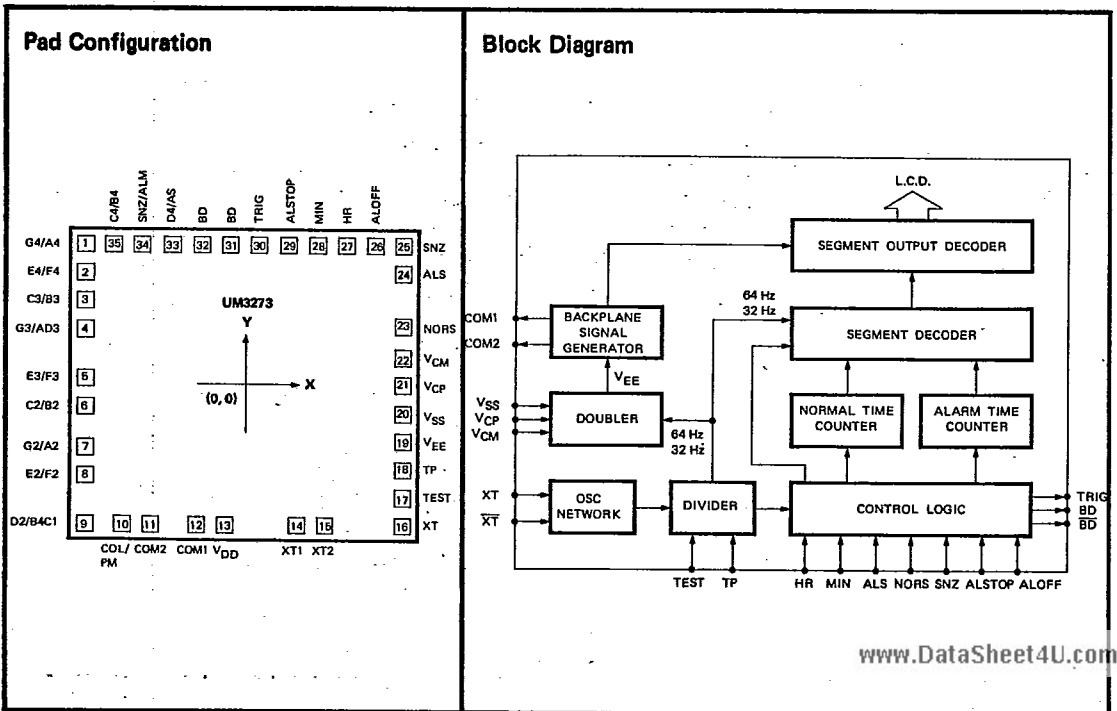

Absolute Maximum Ratings*

DC Supply Voltage	-0.3V to 5.0V
Input/Output Voltage	$V_{SS} - 0.2V$ to $V_{DD} + 0.2V$
Operating Ambient Temperature	-10°C to 60°C
Storage Temperature	-55°C to 125°C

***Comments**

Stress above those listed under "Absolute Maximum Ratings" may cause permanent damage to the device. These are stress ratings only. Functional operation of this device at these or any other conditions above those indicated in the operational sections of this specification is not implied and exposure to absolute maximum rating conditions for extended periods may affect device reliability.

Electrical Characteristics

($V_{SS} = 0V$, $V_{DD} = 1.5V$, $F_{OSC} = 32.768$ KHz, $T_A = 25^\circ C$, unless otherwise specified.)

Parameter	Symbol	Limits			Unit	Test Condition
		Min.	Typ.	Max.		
Supply Voltage	V_{DD}	1.2	1.5	1.65	V	
Supply Current	I_{DD}	-	-	3	μA	LCD Unload BD, BD, TRIG Open
Voltage Doubler Supply	V_{EE}	-1.1	-1.44	-	V	
Oscillator Starting Time	T_{OSC}	-	-	1.0	S	$V_{DD} = 1.45V$
Alarm Output Drive Current	I_{BD}	200	-	-	μA	$V_{BD} = 1V$
Frequency Stability	$\Delta F/F$	-	-	1	ppm	$V_{DD} = 1.35 \sim 1.65V$
Trigger Current	I_{TR}	200	250	-	μA	$V_{DD} = 1.5V$, $V_{OH} = 1.2V$
LCD Drive Current	I_{LCD}	0.1	-	-	μA	
Switch Chatter Time	T_{ct}	-	-	60	ms	
Oscillator Built-in Capacitance	C_D	-	20	-	PF	
Alarm Output Frequency	F_{BD}	-	4096x8x1 4096x8x½	-	Hz	

Pad Description

Pad No.	Designation	Description
1	G4/A4	LCD Segment Drive
2	E4/F4	
3	C3/B3	
4	G3/AD3	
5	E3/F3	
6	C2/B2	
7	G2/A2	
8	E2/F2	
9	D2/BC1	
10	COL/PM	
11	COM2	Backplane Common 2
12	COM1	Backplane Common 1
13	V _{DD}	Positive Power Supply
14	XT ₁	Oscillator Input Pin
15	XT ₂	Oscillator Input Pin
16	XT	Built-In Capacitance Pin
17	TEST	Test Pin
18	TP	Test Pin
19	V _{EE}	Voltage Doubler Supply
20	V _{SS}	Ground
21	V _{CP}	Voltage Doubler Capacitor Positive Pin
22	V _{CM}	Voltage Doubler Capacitor Negative Pin
23	NORS	Normal Time Mode Set Pin
24	ALS	Alarm Time Mode Set Pin
25	SNZ	Snooze Operation Pin
26	ALOFF	Alarm Off Pin
27	HR	Hour Digit Set Pin
28	MIN	Minute Digit Set Pin
29	ALSTOP	Alarm Stop Pin
30	TRIG	Alarm Trigger Pin for Switch Control
31	\overline{BD}	Piezo Buzzer Driving Pin
32	BD	Piezo Buzzer Driving Pin
33	D4/AS	LCD segment Drive
34	SNZ/ALM	
35	C4/B4	

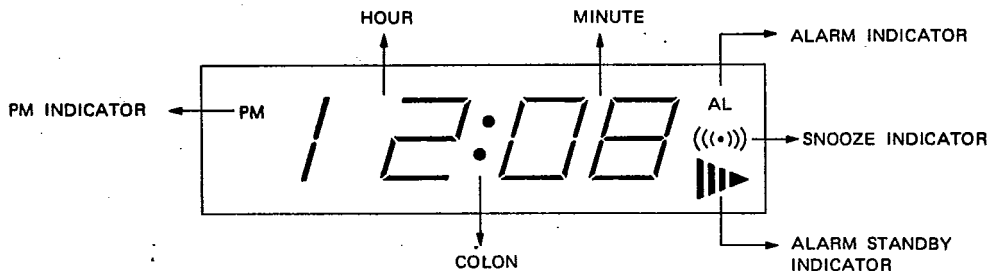
Function Description

- PM indicator on from 12:00 PM to 11:59 PM off from 12:00 AM to 11:59 AM
- Colon on in alarm time mode, and 0.5 sec on 0.5 sec off normal time mode
- Alarm time indicator on in alarm time mode off in normal time mode
- Snooze indicator on in snooze stand-by mod 0.5 sec on 0.5 sec off in snooze mode, and off in alarm off mode
- Alarm indicator on in alarm on mode, off in alarm off mode
- In setting mode, hour digit advances by + 1 when HR switch is depressed
- In setting mode, minute digit advances by + 1 when MIN switch is depressed
- In setting mode, digit (hour or minute) advances automatically at 4 Hz rate by keeping HR switch or MIN switch depressed more than 2 seconds

(1) Mode Select

Alarm time is displayed while HR or MIN switch is depressed, setting mode is selected by depressing either NORS or ALS switch, alarm is selected by depressing

ALMOFF and SNZ switch, test mode is entered by TEST and TP pin.

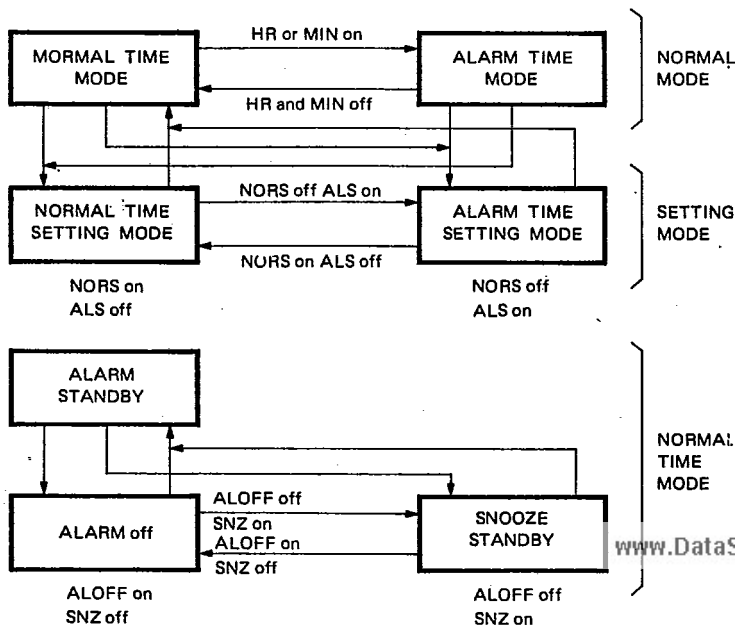

(2) Alarm Function

Alarm buzzer sounds for 1 minute in either alarm standby or snooze standby mode when normal time corresponds to set alarm time when alarm sounds. A momentary closure of alstop, or changing any mode switches, will

stop the alarm buzzer sound.

Alarm function can be operated in all modes except alarm off mode.

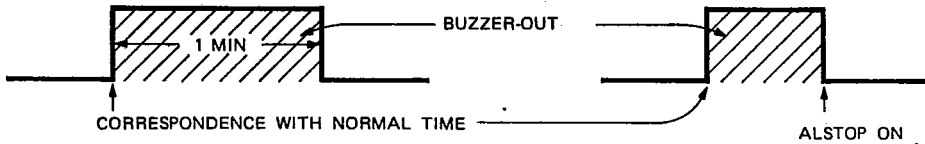

WAVEFORM OF ALARM SOUND

4096 x 8 x 1 Hz

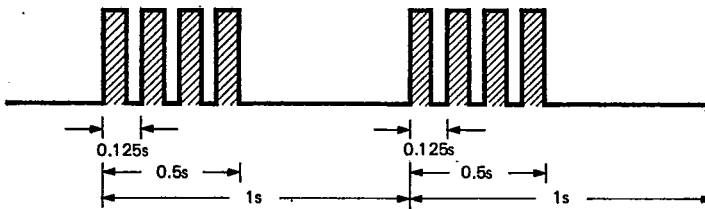

4096 x 8 x 1/2 Hz

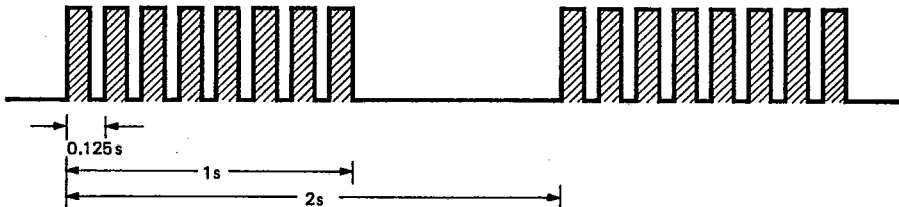

(3) Snooze Function

Snooze function can be operated in alarm time mode, alarm time setting mode, and normal time setting mode, when snooze standby mode is selected and normal time corresponds to alarm time, buzzer sound will be output and snooze indicator will flash at 1 Hz rate, 0.5 SEC. on 0.5 SEC off, and snooze function will operate.

start output 4 minutes later and will continue.

If alstop switch is not turned on while buzzer is sounding, buzzer sound will stop after 1 minute and snooze operation will be released and return to snooze standby mode.

Snooze function can be operated in all modes except alarm off mode switches.

If alstop switch is turned on while buzzer is sounding, alarm sound will be suspended once, but buzzer sound will

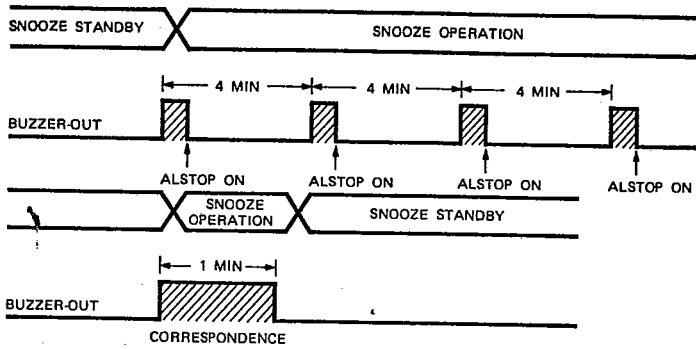
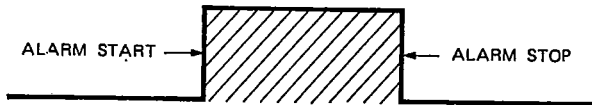
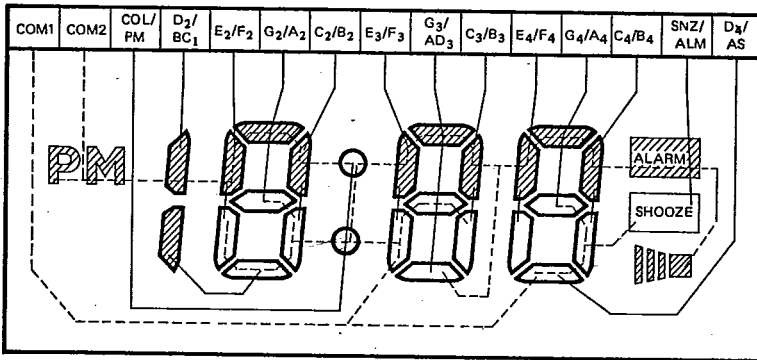
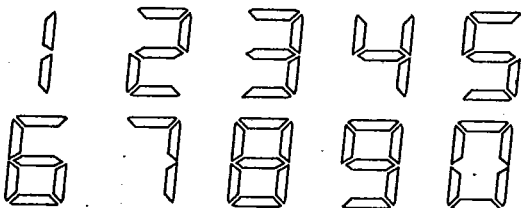
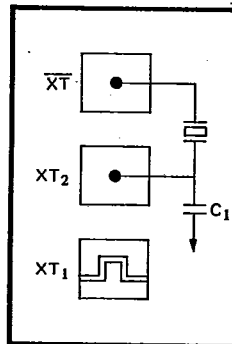
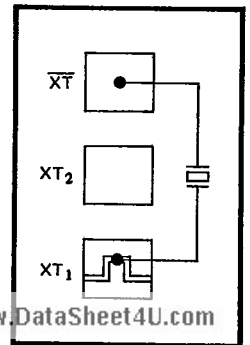
(4) Trigger Function

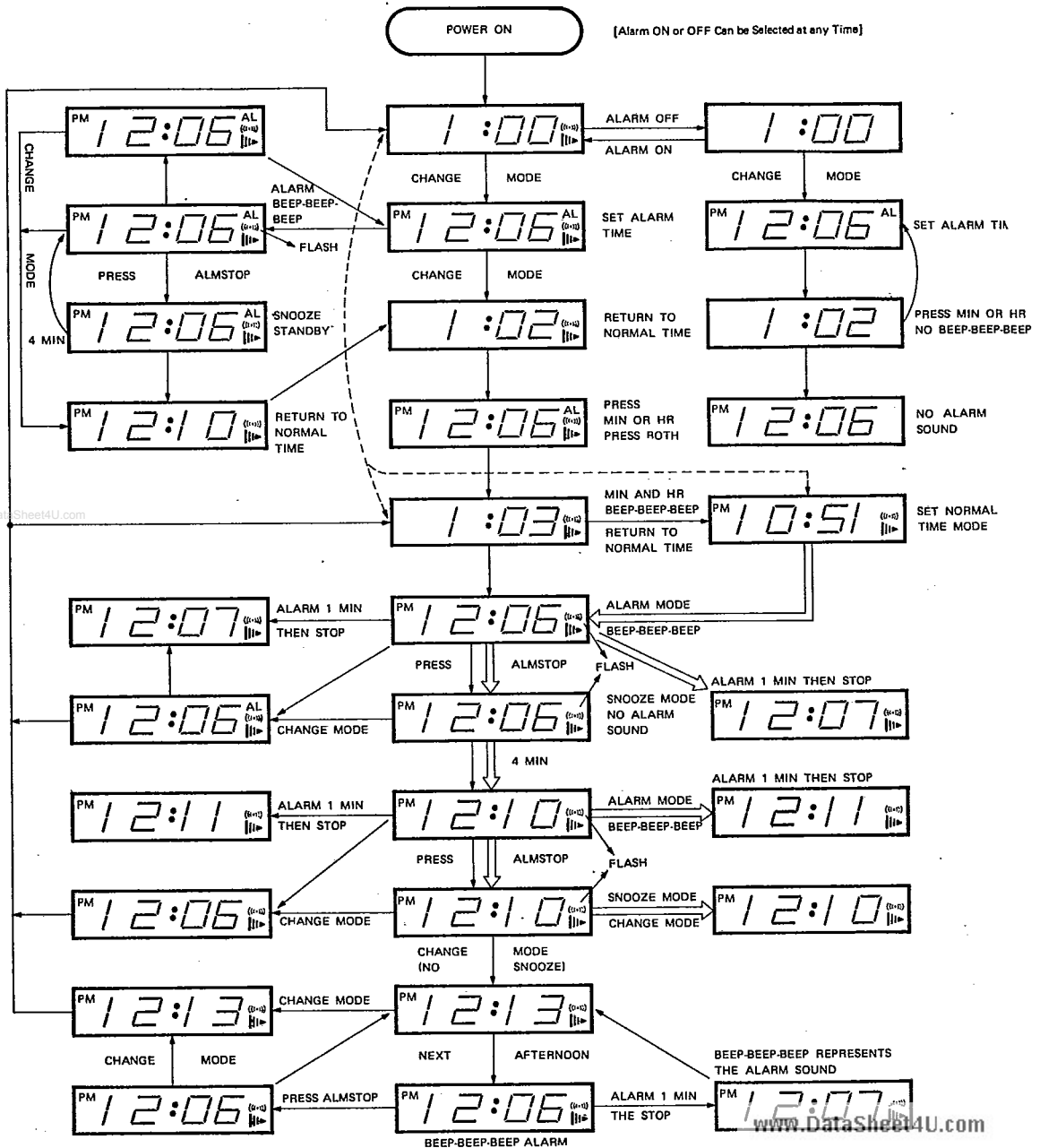
(5) LCD Layout

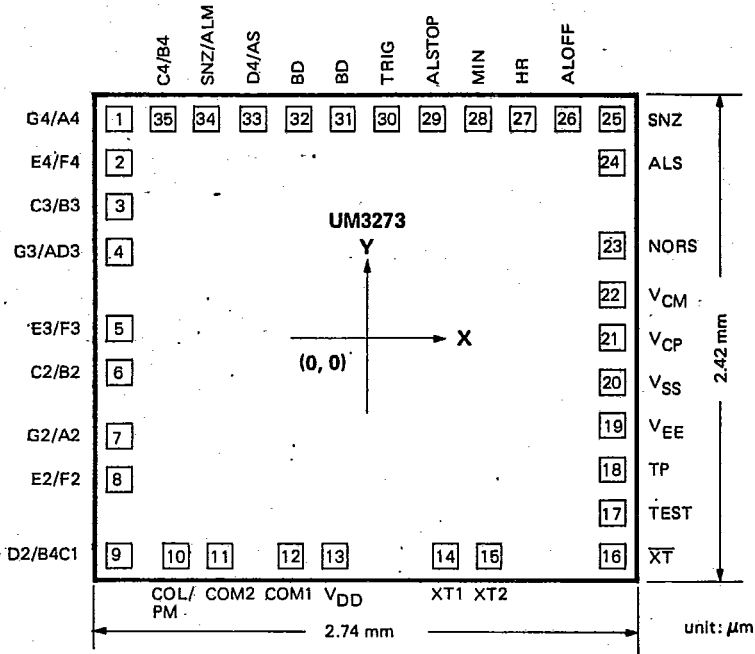
Display Format

(6) Built-In Oscillator

a) With Trimmer

b) Without Trimmer

Operation Flow Chart

Bonding Diagram

www.DataSheet4U.com

Pad No.	Designation	X	Y	Pad No.	Designation	X	Y
1	G4/A4	-1204	1005	19	VEE	1158	- 401
2	E4/F4	-1204	803	20	VSS	1204	- 202
3	C3/B3	-1204	549	21	VCP	1204	- 1
4	G3/AD3	-1204	349	22	VCM	1204	199
5	E3/F3	-1204	27	23	NORS	1204	398
6	C2/B2	-1204	- 73	24	ALS	1204	687
7	G2/A2	-1201	- 491	25	SNZ	1204	942
8	E2/F2	-1202	- 691	26	ALOFF	980	955
9	D2/BC1	-1202	-1011	27	HR	752	975
10	COL/PM	- 944	-1011	28	MIN	462	1012
11	COM2	- 744	-1012	29	ALSTOP	244	1018
12	COM1	- 416	-1011	30	TRIG	- 4	983
13	VDD	- 277	-1012	31	BD	- 204	983
14	XT1	316	-1012	32	BD	- 404	983
15	XT2	502	-1011	33	D4/AS	- 604	1005
16	XT	1204	-1012	34	SNZ/ALM	- 804	1005
17	TEST	1204	- 801	35	C4/B4	-1004	1005
18	TP	1204	- 601				

Ordering Information

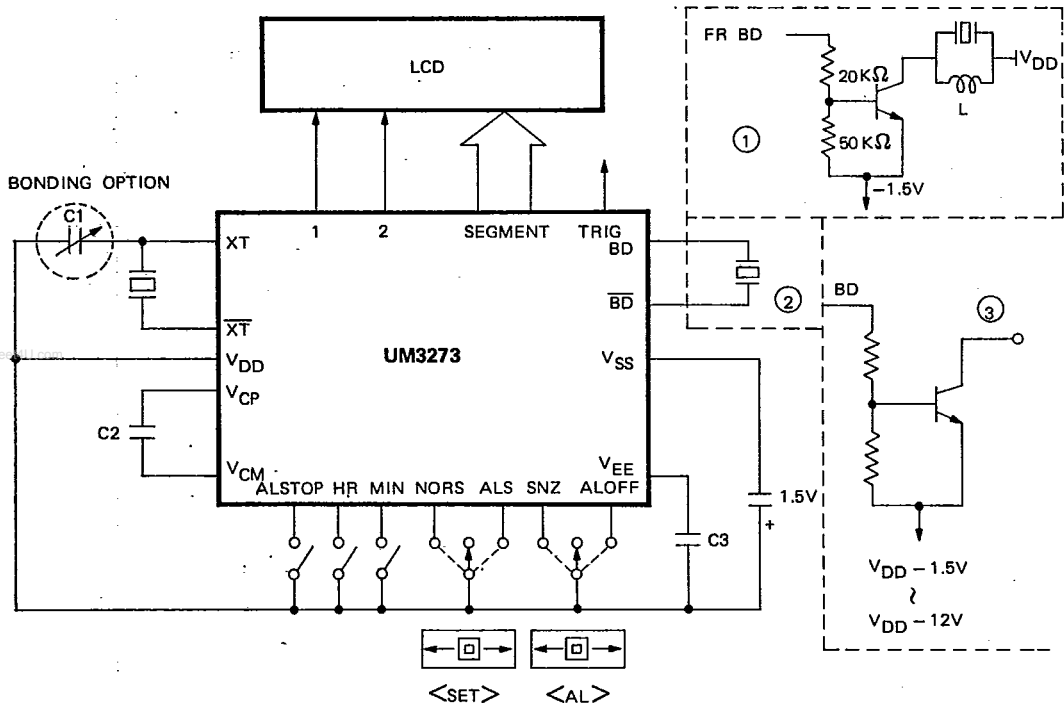
Part No.	Items	Alarm Output		LCD Colon	
		2048 x 8 x 1 Hz	2048 x 8 x ½ Hz	Flash	Freeze
UM3273		✓		✓	
UM3273-1		✓			✓
UM3273-2			✓	✓	
UM3273-3			✓		✓

Typical Application Circuit

$C1 = 5 \sim 35$ PF

$C2, C3 \sim 0.1\mu$ F

*There is a bonding option capacitance (20 PF) that can replace $C1$.

There are three types of buzzer application circuits, as indicated by the areas boxed by dotted lines.