

-30V P-Channel Enhancement Mode MOSFET

■ DESCRIPTION

The UM3407A is the P-Channel logic enhancement mode power field effect transistor is produced using high cell density advanced trench technology to provide excellent $R_{DS(ON)}$.

This device is suitable for use as a load switch or in PWM and gate charge for most of the synchronous buck converter applications

■ FEATURE

- ◆ -30V/-4.3A, $R_{DS(ON)}=42m\Omega$ (typ.)@ $V_{GS}=-10V$
- ◆ -30V/-3.0A, $R_{DS(ON)}=68m\Omega$ (typ.)@ $V_{GS}=-4.5V$
- ◆ Super high design for extremely low $R_{DS(ON)}$
- ◆ Exceptional on-resistance and Maximum DC current capability
- ◆ Full RoHS compliance
- ◆ SOT23-3L package design

■ APPLICATIONS

- ◆ High Frequency Point-of-load Synchronous
- ◆ Buck Converter for MB/NB/UMPC/VGA
- ◆ DC/DC Converter
- ◆ Load Switch

■ PIN CONFIGURATION

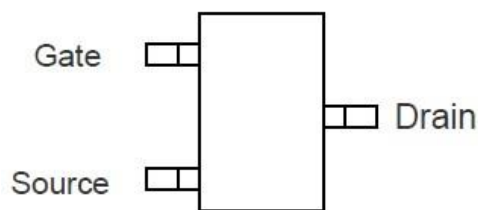

TOP VIEW
SOT-23

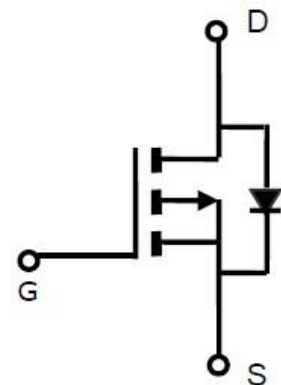

P-Channel

■ PART NUMBER INFORMATION

UM3407AA- <u>BB</u> <u>C</u>	A= Package Code S: SOT23-3L BB=Handing Code TR: Tape&Reel C=Lead Plating Code G: Green Product
------------------------------	---

■ ORDERING INFROMATION

Part Number	Package Code	Package	Shipping
UM3407AS-TRG	S	SOT23-3L	3000EA / T&R

- ※ Year Code : 0~9
- ※ Week Code : A~Z(1-26); a~z(27~52)
- ※ G : Green Product. This product is RoHS compliant.

■ ABSOLUTE MAXIMUM RATINGS ($T_A = 25^\circ\text{C}$ Unless otherwise noted)

Symbol	Parameter	Typical	Unit
V_{DSS}	Drain-Source Voltage	-30	V
V_{GSS}	Gate-Source Voltage	± 20	V
I_D	Continuous Drain Current ($T_C=25^\circ\text{C}$)	-4.3	A
	Continuous Drain Current ($T_C=70^\circ\text{C}$)		
I_{DM}	Pulsed Drain Current	-20	A
I_S	Continuous Source Current (Diode Conduction)	-1.4	A
P_D	Power Dissipation	$T_A=25^\circ\text{C}$	W
		$T_A=70^\circ\text{C}$	
T_J	Operation Junction Temperature	150	$^\circ\text{C}$
T_{STG}	Storage Temperature Range	-55~+150	$^\circ\text{C}$
$R_{\theta JA}$	Thermal Resistance Junction to Ambient	120	$^\circ\text{C}/\text{W}$

Note: Absolute maximum ratings are those values beyond which the device could be permanently damaged. Absolute maximum ratings are stress rating only and functional device operation is not implied

■ **ELECTRICAL CHARACTERISTICS** ($T_A=25^\circ\text{C}$ Unless otherwise noted)

Symbol	Parameter	Condition	Min	Typ	Max	Unit
Static Parameters						
$V_{(BR)DSS}$	Drain-Source Breakdown Voltage	$V_{GS}=0V, I_D=-250\mu A$	-30			V
$V_{GS(th)}$	Gate Threshold Voltage	$V_{DS}=V_{GS}, I_D=-250\mu A$	-1.0		-2.0	V
I_{GSS}	Gate Leakage Current	$V_{DS}=0V, V_{GS}=\pm 20V$			± 100	nA
I_{DSS}	Zero Gate Voltage Drain Current	$V_{DS}=-24V, V_{GS}=0$			-1	uA
		$V_{DS}=-24V, V_{GS}=0$ $T_J=55^\circ\text{C}$			-5	
$R_{DS(ON)}$	Drain-Source On-Resistance	$V_{GS}=-20V, I_D=-4.3A$		42	48	m Ω
		$V_{GS}=-4.5V, I_D=-3.0A$		68	85	
Source-Drain Diode						
V_{SD}	Diode Forward Voltage	$I_S=-1.0A, V_{GS}=0V$		-0.7	-1.0	V
Dynamic Parameters						
Q_g	Total Gate Charge	$V_{DS}=-20V$ $V_{GS}=-4.5V$ $I_D=-4.0A$		6		nC
Q_{gs}	Gate-Source Charge			2.7		
Q_{gd}	Gate-Drain Charge			3.1		
C_{iss}	Input Capacitance	$V_{DS}=-25V$ $V_{GS}=0V$ $f=1\text{MHz}$		645		pF
C_{oss}	Output Capacitance			272		
C_{rss}	Reverse Transfer Capacitance			105		
$T_{d(on)}$	Turn-On Time	$V_{DS}=-12V$ $I_D=-4A$		9		nS
T_r				16.5		
$T_{d(off)}$	Turn-Off Time	$V_{GEN}=-10V$ $R_G=3.3\Omega$		22		
T_f				21		

Note: 1. Pulse test: pulse width \leq 300uS, duty cycle \leq 2%

2. Static parameters are based on package level with recommended wire bonding

■ **TYPICAL CHARACTERISTICS** (25°C Unless Note)

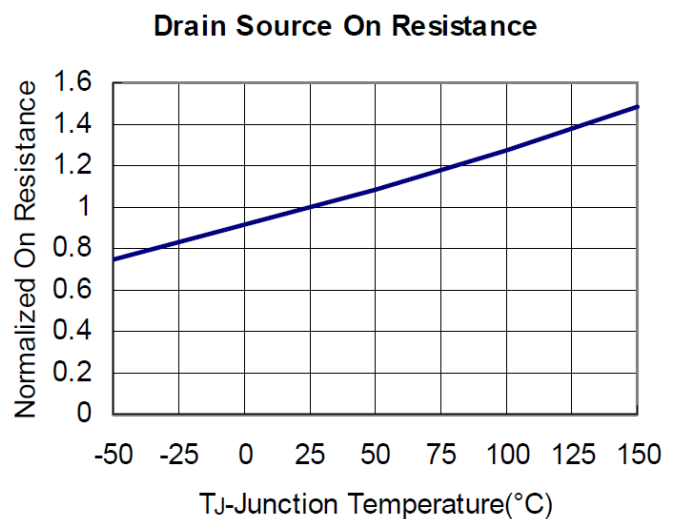
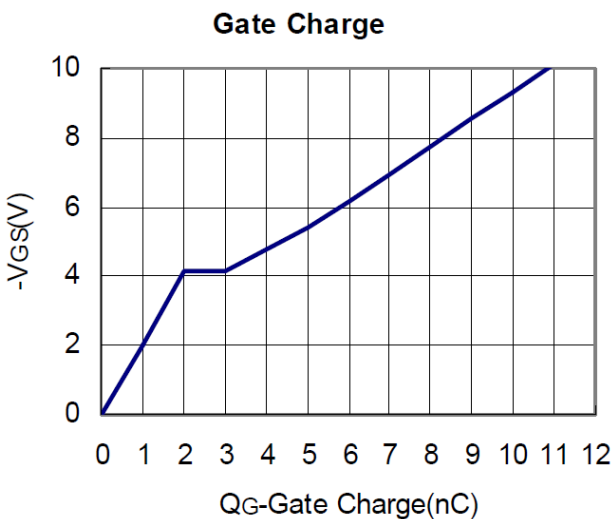
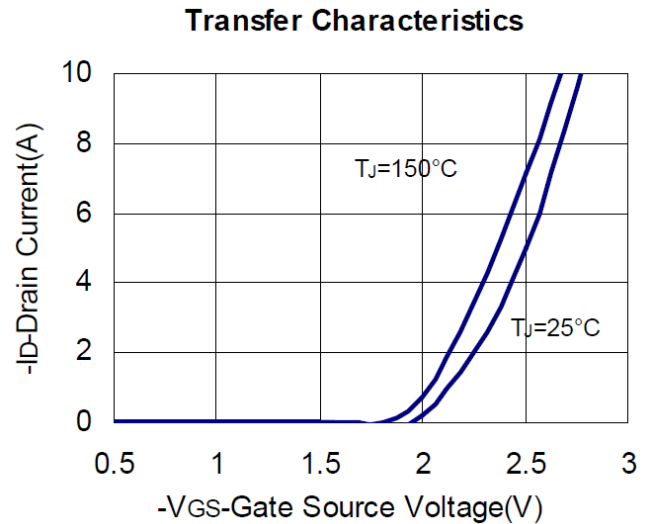
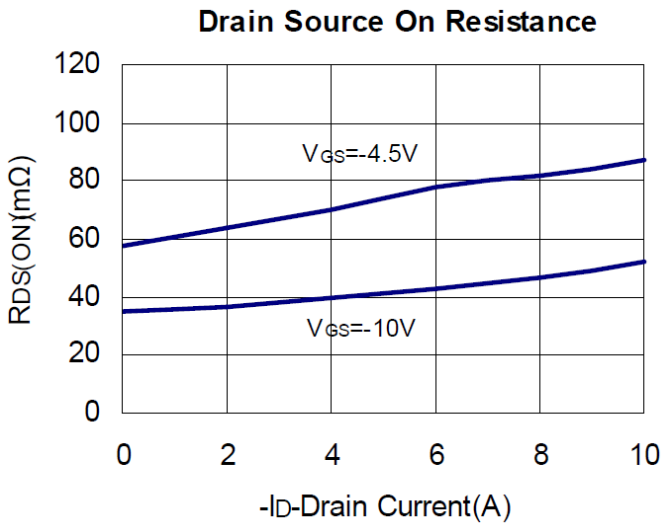
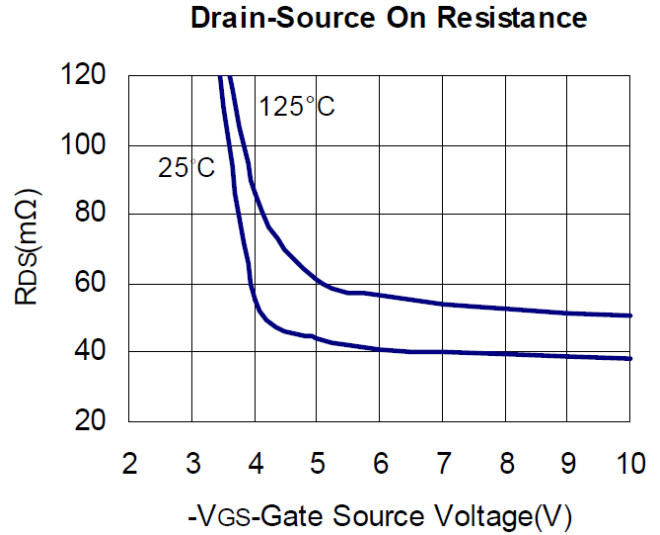
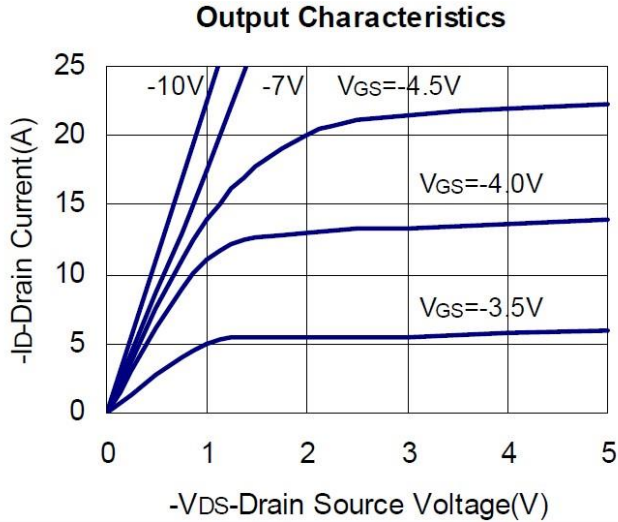

■ TYPICAL CHARACTERISTICS (continuous)

Capacitance

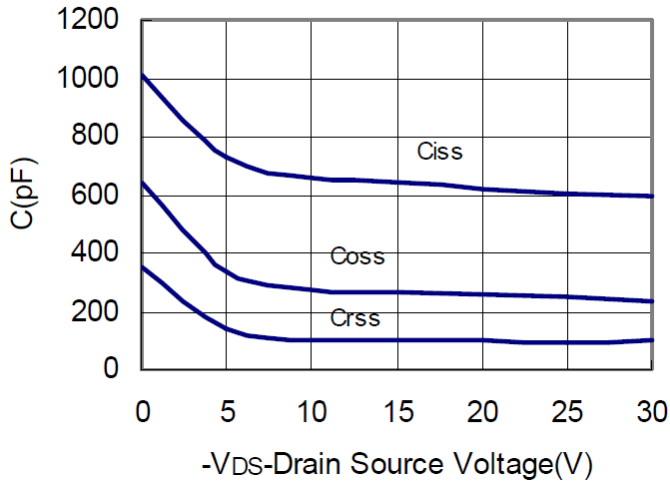

Source Drain Diode Forward

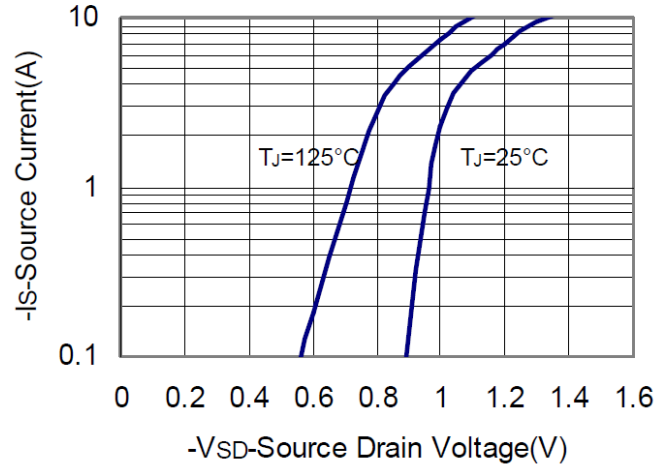

Power Dissipation

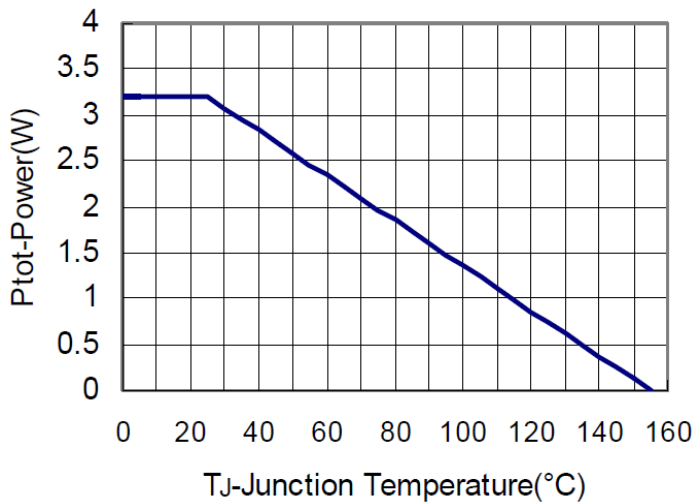

Drain Current

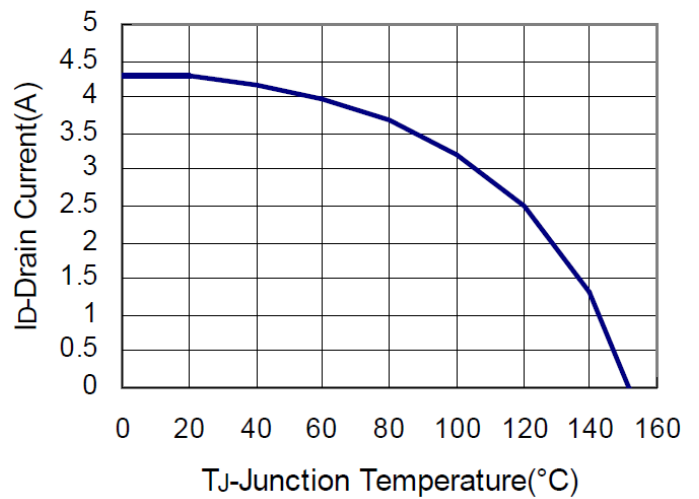

Thermal Transient Impedance

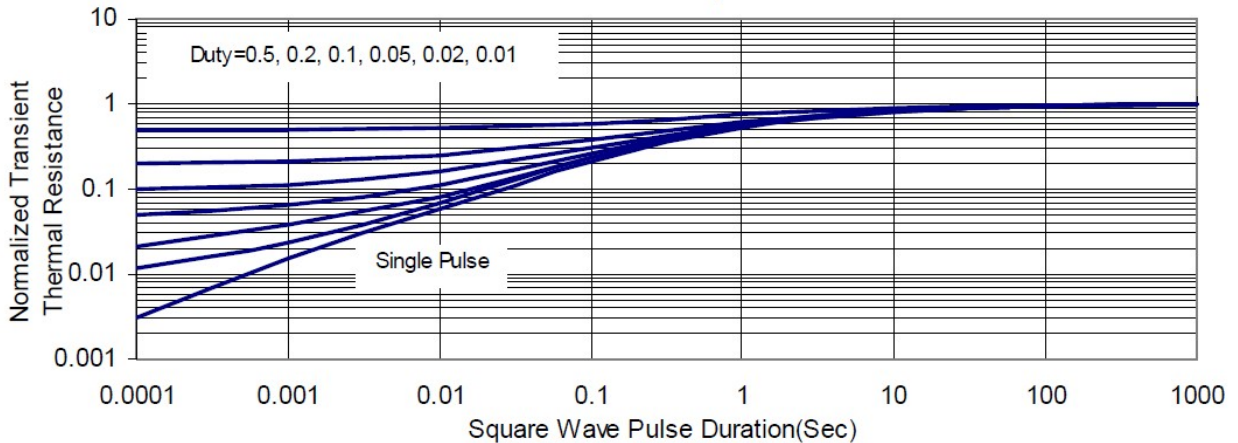

■ SOT23-3L PACKAGE OUTLINE DIMENSIONS

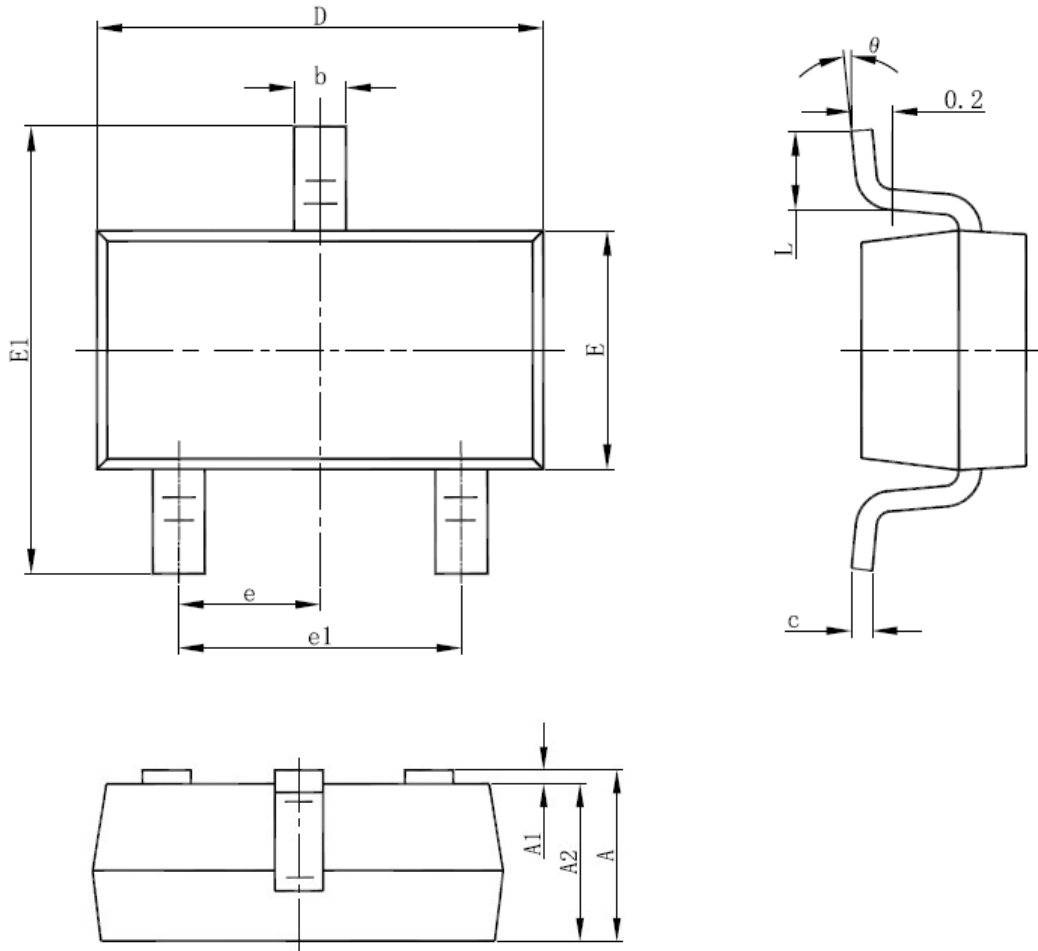

Symbol	Dimensions In Millimeters		Dimensions In Inches	
	Min	Max	Min	Max
A	1.050	1.250	0.041	0.049
A1	0.000	0.100	0.000	0.004
A2	1.050	1.150	0.041	0.045
b	0.300	0.500	0.012	0.020
c	0.100	0.200	0.004	0.008
D	2.820	3.020	0.111	0.119
E	1.500	1.700	0.059	0.067
E1	2.650	2.950	0.104	0.116
e	0.950(BSC)		0.037(BSC)	
e1	1.800	2.000	0.071	0.079
L	0.300	0.600	0.012	0.024
theta	0°	8°	0°	8°

■ SOLDERING METHODS FOR UNIVERCHIP

Storage environment Temperature=10°C~35°C Humidity=65%±15%

Reflow soldering of surface mount device

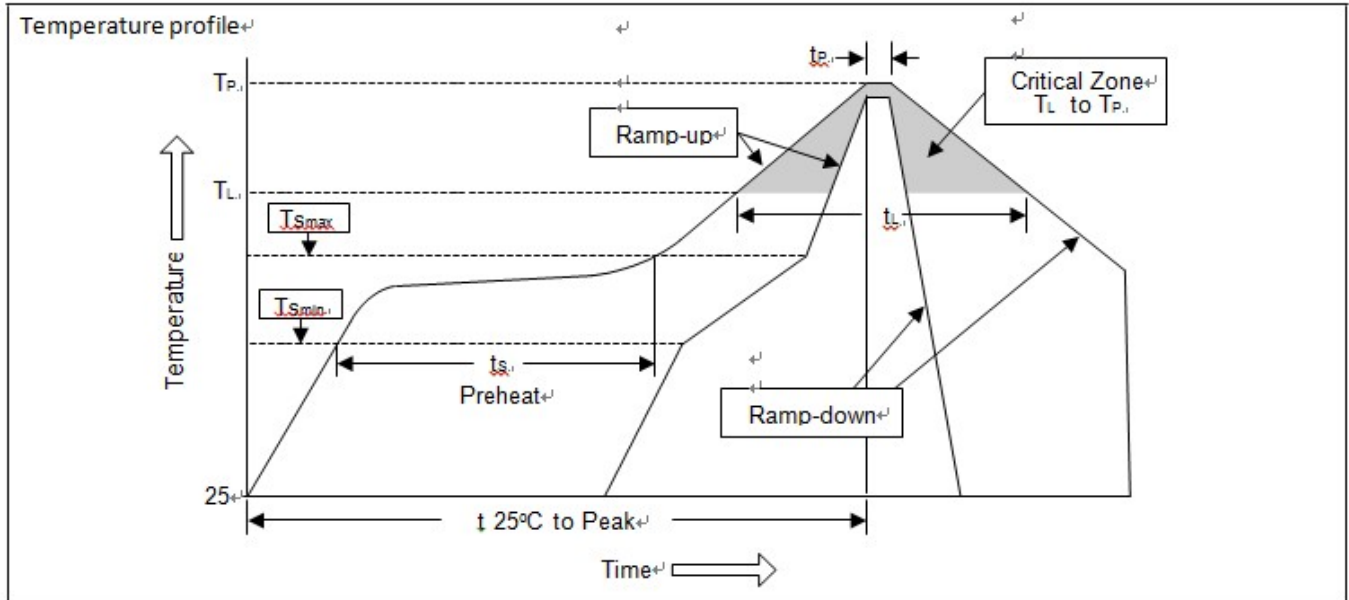

Profile Feature	Sn-Pb Eutectic Assembly	Pb free Assembly
Average ramp-up rate (T_L to T_P)	<3°C/sec	<3°C/sec
Preheat		
-Temperature Min (T_{Smin})	100°C	150°C
-Temperature Max (T_{Smax})	150°C	200°C
-Time (min to max) (t_s)	60~120 sec	60~180 sec
T_{Smax} to T_L		
-Ramp-up Rate	<3°C/sec	<3°C/sec
Time maintained above		
-Temperature (T_L)	183°C	217°C
-Time (t_L)	60~150 sec	60~150 sec
Peak Temperature (T_P)	240°C+0/-5°C	260°C+0/-5°C
Time within 5°C of actual Peak Temperature (t_p)	10~30 sec	20~40 sec
Ramp-down Rate	<6°C/sec	<6°C/sec
Time 25°C to Peak Temperature	<6 minutes	<6 minutes

Flow (wave) soldering (solder dipping)

Product	Peak Temperature	Dipping Time
Pb device	245°C±5°C	5sec±1sec
Pb-Free device	260°C+0/-5°C	5sec±1sec



This integrated circuit can be damaged by ESD UniverChip Corporation recommends that all integrated circuits be handled with appropriate precautions. Failure to observe proper handling and installation procedure can cause damage. ESD damage can range from subtle performance degradation to complete device failure. Precision integrated circuits may be more susceptible to damage because very small parametric changes could cause the device not to meet its published specifications.