

600mA, 600kHz Step-Up DC-DC Converter

UM3433 SOT23-6

General Description

The UM3433 is synchronous rectified, fixed frequency, step-up DC/DC converter series delivering high efficiency in a low profile SOT23-6 package. It is available both in 3.3V/3.0V fixed output and adjustable output. With an internal NMOS switch and PMOS synchronous rectifier and high switching frequency of 600KHz, the UM3433 is capable of supplying 3.3V output at 100mA from a single AA cell input using low profile inductors and ceramic capacitors. Current mode PWM control with internal compensation cuts external parts count thereby saving BOM cost and PCB real estate. At light loads, UM3433 enters automatically into power saving mode to keep high efficiency at light load. Anti-ringing control circuitry inside reduces EMI interferences by damping the inductor in discontinuous mode. The device also features low shutdown current of under 1 μ A. With inrush current limiting and soft start built inside, it also limits the inrush of current during start up, minimizing surge currents seen by the input supply.

Applications

- MP3 Players
- Digital Cameras
- LCD Bias Supplies
- Handheld Instruments
- Wireless Handsets
- GPS Receivers

Features

- Up to 92% efficiency
- Low Voltage Start-Up: 0.9V
- Inrush current limiting and internal soft start
- Automatic Power-Saving Mode Operation with typical IQ as 20 μ A
- Short Circuit Protection
- 600kHz Switching Frequency for low profile inductor/capacitor
- Anti-ringing Control to minimizes EMI
- Output range: 2.5V to 5V, with 3.3V/3.0V fixed output option

Pin Configurations

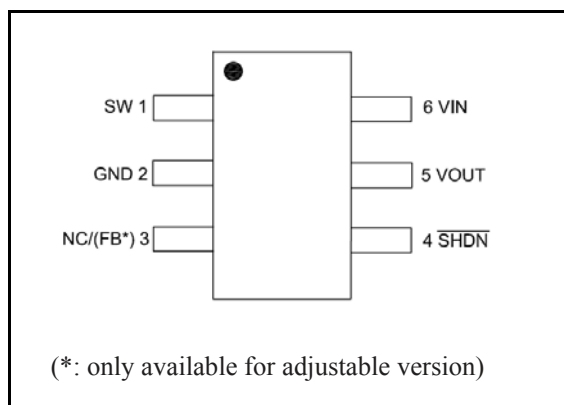

Top View

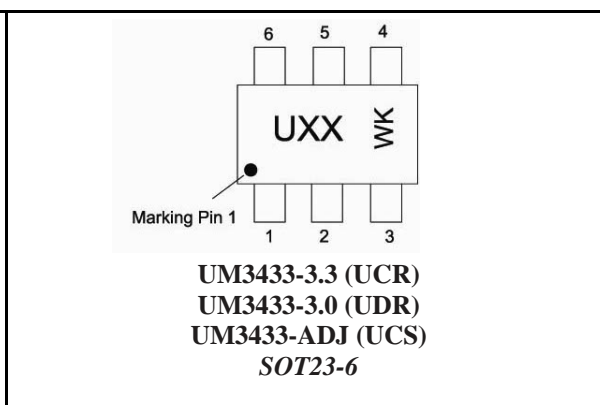

Pin Description

Pin Number	Symbol	Description
1	SW	Switch pin for external inductance
2	GND	Ground
3	NC(UM3433-3.3/3.0)	Not Connect
	FB(UM3433-ADJ)	Feedback input pin
4	$\overline{\text{SHDN}}$	Logic Controlled Shutdown Input
		$\overline{\text{SHDN}}$ =high, Normal operation mode $\overline{\text{SHDN}}$ =low, shutdown mode
5	VOUT	Output Voltage
6	VIN	Input Voltage

Ordering Information

Part Number	Packaging Type	Marking Code	Shipping Qty
UM3433-3.3	SOT23-6	UCR	3000pcs/7Inch Tape & Reel
UM3433-3.0	SOT23-6	UDR	3000pcs/7Inch Tape & Reel
UM3433-ADJ	SOT23-6	UCS	3000pcs/7Inch Tape & Reel

Absolute Maximum Ratings

Symbol	Parameter	Value	Unit
V_{IN}	V_{IN} Supply Voltage	-0.3 to +6V	V
V_{SW}	SW Voltage	-0.3 to +6V	V
V_{FB}	FB Voltage	-0.3 to +6V	V
$V_{\overline{\text{SHDN}}}$	$\overline{\text{SHDN}}$ Voltage	-0.3 to +6V	V
V_{OUT}	Output Voltage	-0.3 to +6V	V
T_{OP}	Operating Temperature Range	-40 to +85	°C
T_{STG}	Storage Temperature Range	-65 to +150	°C
T_{L}	Maximum Lead Temperature (Soldering , 10s)	+300	°C

Maximum ratings are those values beyond which device damage can occur. Maximum ratings applied to the device are individual stress limit values (not normal operating conditions) and are not valid simultaneously. If these limits are exceeded, device functional operation is not implied, damage may occur and reliability may be affected.

Electrical Characteristics

($V_{IN} = +1.2V$, $V_{OUT} = +3.3V$ $T_A = +25^\circ C$, unless otherwise noted.)

Parameter	Test Conditions	Min	Typ	Max	Unit
Input Voltage Range		0.9		2.5	V
Fixed Output Voltage	UM3433-3.3, $I_{load} = 100mA$	3.22	3.3	3.38	V
	UM3433-3.0, $I_{load} = 100mA$	2.92	3.0	3.08	
Output Voltage Adjustable Range	UM3433-ADJ	2.5		5	V
Feedback Voltage		1.192	1.230	1.268	V
Quiescent Current (power-saving mode)	$I_{load} = 0mA$		20		μA
Quiescent Current (Active)	$I_{load} = 100mA$		380	550	μA
Quiescent Current (shutdown)	SHDN=0V			1	μA
NMOS Leakage	$V_{SW} = 3.3V$		0.1		μA
PMOS Leakage			0.1		μA
NMOS On-resistance			0.35		Ω
PMOS On-resistance			0.45		Ω
NMOS Current limit		600	850		mA
Power-Saving Mode Operation Current threshold	$L = 10\mu H$ (Note)		3		mA
Current Limit Delay to Output			40		ns
Switching Frequency	$I_{load} = 100mA$, SHDN=1V		600		kHz
SHDN Input High	$I_{load} = 100mA$	1			V
SHDN Input Low	$I_{load} = 100mA$			0.35	V
SHDN Input Current	$I_{load} = 100mA$, SHDN=1V		0.01	1	μA

Note: Design guaranteed.

Typical Operating Characteristics

Efficiency vs Output Current

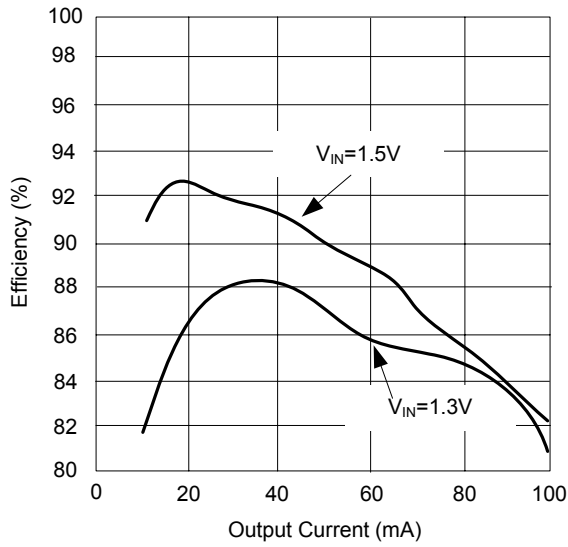

Efficiency vs Input Voltage

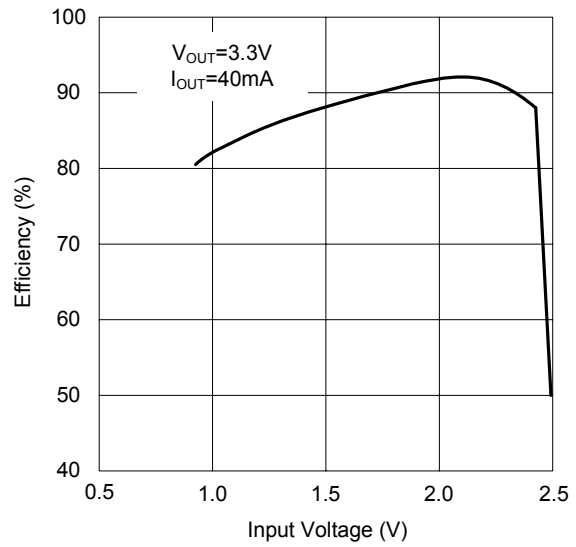

Output Voltage vs Temperature

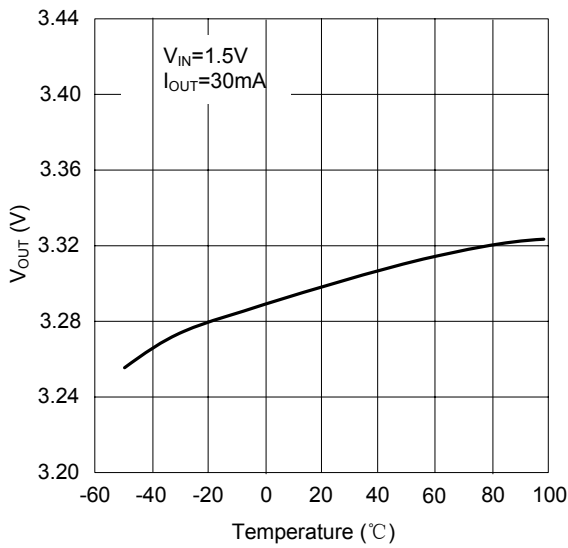

Power-Saving Mode Quiescent Current vs Temperature

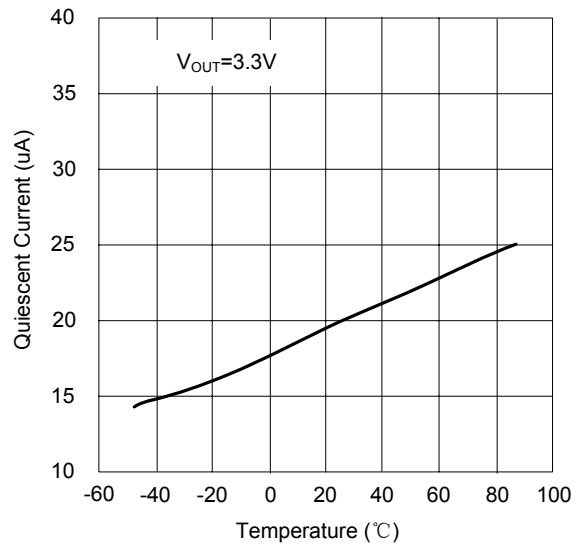

Typical Operating Characteristics

Fixed Frequency Discontinuous Mode Operation

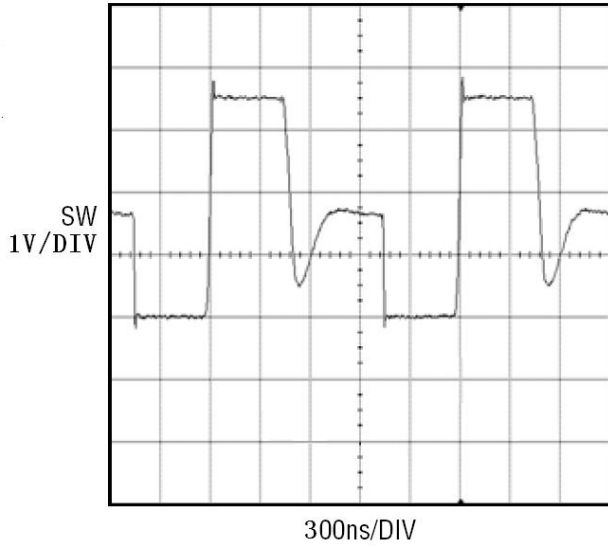

Fixed Frequency Continuous Mode Operation

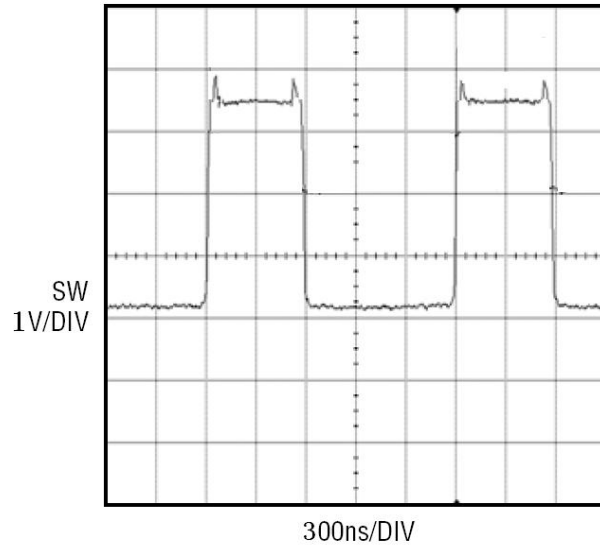

Power-Saving Mode Operation

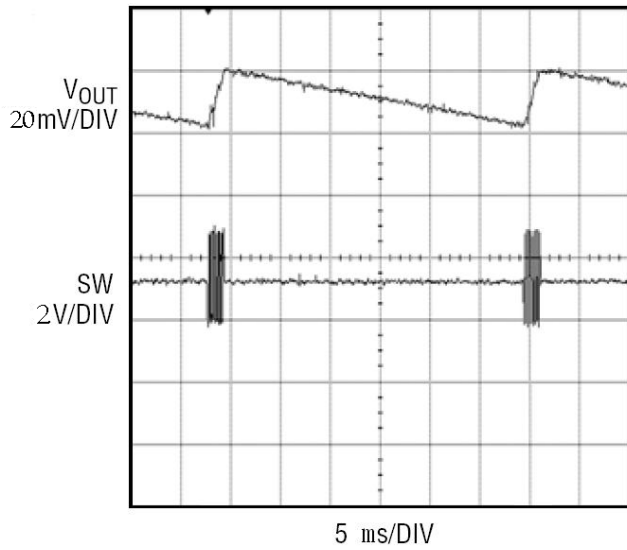

Pin Functions

SW (Pin 1): Switch Pin. Connect inductor between SW and V_{IN} . Keep these PCB trace lengths as short and wide as possible to reduce EMI and voltage overshoot.

GND (Pin 2): Signal and Power Ground. Provide a short direct PCB path between GND and the (-) side of the output capacitor(s).

NC (Pin 3): Not Connect.

FB (Pin 3): Feedback input. Connect resistor divider tap to this pin. The output voltage can be adjusted from 2.5V to 5V by:

$$V_{OUT} = V_{FB} \times (1 + R1/R2)$$

SHDN (Pin 4): Logic Controlled Shutdown Input.

SHDN=High: Normal free running operation, 600kHz typical operating frequency.

SHDN=Low: Shutdown, quiescent current $< 1\mu A$. Output capacitor can be completely discharged through the load.

VOU (Pin 5): Output Voltage Sense Input and Drain of the Internal Synchronous Rectifier MOSFET. Bias is derived from V_{OUT} . PCB trace length from V_{OUT} to the output filter capacitor(s) should be as short and wide as possible.

VIN (Pin 6): Battery Input Voltage. The device gets its start-up bias from V_{IN} . Once V_{OUT} exceeds V_{IN} , bias comes from V_{OUT} . Thus, once started, operation is completely independent from V_{IN} . Operation is only limited by the output power level and the battery's internal series resistance.

Typical Application Circuits

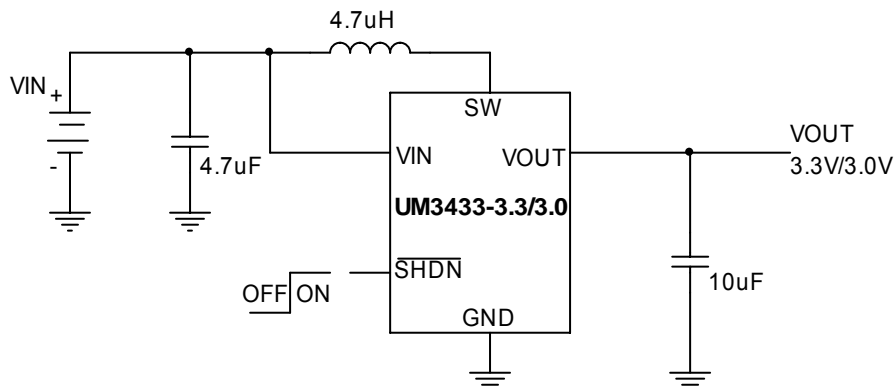

Figure 1 Fixed output application circuit

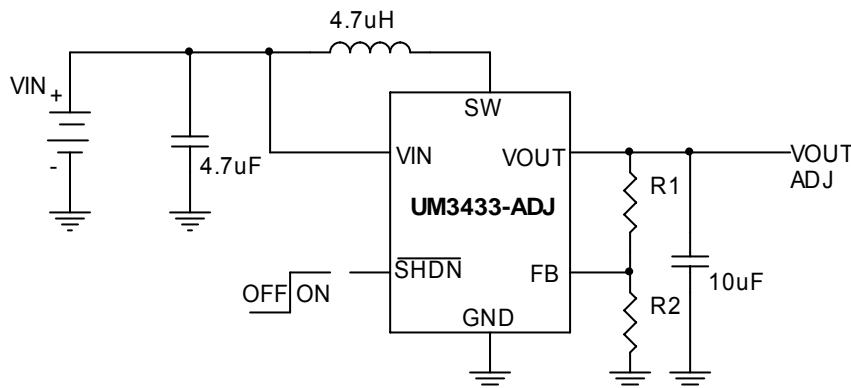

Figure 2 Adjustable output application circuit

Applications Information

Inductor Selection

The UM3433 can utilize small surface mount and chip inductors due to its 600kHz switching frequency. Typically, a 4.7μH inductor is recommended for most applications. Larger values of inductance will allow greater output current capability by reducing the inductor ripple current. Increasing the inductance above 10μH will increase size while providing little improvement in output current capability.

The approximate output current capability of the UM3433 versus inductance value is given in the equation below.

$$I_{OUT(MAX)} = \eta \cdot \left(I_P - \frac{V_{IN} \cdot D}{f \cdot L \cdot 2} \right) \cdot (1-D)$$

where:

η = estimated efficiency

I_P = peak current limit value (0.6A)

V_{IN} = input (battery) voltage

D = steady-state duty ratio = $(V_{OUT} - V_{IN})/V_{OUT}$

f = switching frequency (600kHz typical)

L = inductance value

The inductor current ripple is typically set for 20% to 40% of the maximum inductor current (I_P). High frequency ferrite core inductor materials reduce frequency dependent power losses compared to cheaper powdered iron types, improving efficiency. The inductor should have low ESR (series resistance of the windings) to reduce the I^2R power losses, and must be able to handle the peak inductor current without saturating. Molded chokes and some chip inductors usually do not have enough core to support the peak inductor currents of 850mA seen on the UM3433. To minimize radiated noise, use a toroid, pot core or shielded bobbin inductor.

Output and Input Capacitor Selection

Low ESR (equivalent series resistance) capacitors should be used to minimize the output voltage ripple. Multilayer ceramic capacitors are an excellent choice as they have extremely low ESR and are available in small footprints. A 4.7μF to 15μF output capacitor is sufficient for most applications. Larger values up to 22μF may be used to obtain extremely low output voltage ripple and improve transient response. An additional phase lead capacitor may be required with output capacitors larger than 10μF to maintain acceptable phase margin. X5R and X7R dielectric materials are preferred for their ability to maintain capacitance over wide voltage and temperature ranges.

Low ESR input capacitors reduce input switching noise and reduce the peak current drawn from the battery. It follows that ceramic capacitors are also a good choice for input decoupling and should be located as close as possible to the device. A 10μF input capacitor is sufficient for virtually any application. Larger values may be used without limitations.

Package Information

UM3433: SOT23-6

Outline Drawing

Symbol	DIMENSIONS			
	MILLIMETERS		INCHES	
	Min	Max	Min	Max
A	1.050	1.250	0.041	0.049
A1	0.000	0.100	0.000	0.004
A2	1.050	1.150	0.041	0.045
b	0.300	0.500	0.012	0.020
c	0.100	0.200	0.004	0.008
D	2.820	3.020	0.111	0.119
E	1.500	1.700	0.059	0.067
E1	2.650	2.950	0.104	0.116
e	0.950REF		0.037REF	
e1	1.800	2.000	0.071	0.079
L	0.600REF		0.023REF	
L1	0.300	0.600	0.012	0.024
θ	0°	8°	0°	8°

Land Pattern

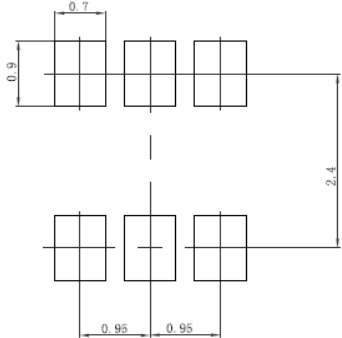
	<p>NOTES:</p> <ol style="list-style-type: none"> 1. Compound dimension: 2.92×1.60 ; 2. Unit: mm; 3. General tolerance ±0.05mm unless otherwise specified; 4. The layout is just for reference.
---	--

Tape and Reel Orientation

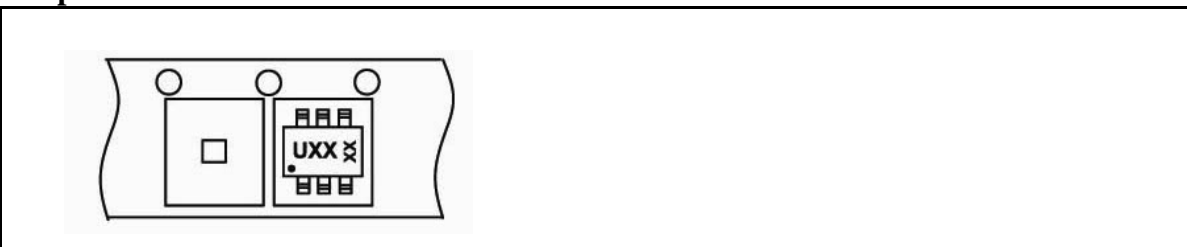

IMPORTANT NOTICE

The information in this document has been carefully reviewed and is believed to be accurate. Nonetheless, this document is subject to change without notice. Union assumes no responsibility for any inaccuracies that may be contained in this document, and makes no commitment to update or to keep current the contained information, or to notify a person or organization of any update. Union reserves the right to make changes, at any time, in order to improve reliability, function or design and to attempt to supply the best product possible.



Union Semiconductor, Inc

Add: 7F, No. 5, Bibo Road, Shanghai 201203

Tel: 021-51097928

Fax: 021-51026018

Website: www.union-ic.com