

## Low-Profile, 600mA, Synchronous Step-Down Converter with Integrated Inductor

### UM3506QA QFN14 2.5×2.5

#### General Description

The UM3506QA is a complete power conversion module requiring only two low cost ceramic MLCC capacitors. Inductor, MOSFETs, synchronous rectifier and control IC are integrated into a tiny 2.5mm×2.5mm×1.05mm QFN package. The UM3506QA is engineered to simplify design and to minimize layout constraints. It is an ideal choice to be used to replace less efficient LDO to achieve improved efficiency in space restricted applications. The UM3506QA is capable of delivering 600mA output current over a wide input voltage range from 2.5V to 5.5V.

The UM3506QA is a high-efficiency, step-down DC-DC converter with a constant PWM frequency, current mode architecture. The UM3506QA automatically turns off the synchronous rectifier while the inductor current is low, and enters pulse skipping mode at light load condition. This can increase efficiency. The operation frequency is set to 2.25MHz at normal load condition. The UM3506QA enters shutdown mode and consumes less than 0.1μA when EN pin is pulled low.

#### Applications

- Cellular and Smart Phones
- MCU, DSP and FPGA Core Supplies
- Wireless and DSL Modems
- Portable Game Consoles and Instruments
- PDAs, GPS
- Bluetooth Headsets
- Battery-Powered Devices

#### Features

- Tiny QFN Package 2.5×2.5×1.05
- Integrated Inductor
- No Schottky Diode Required
- High Efficiency: Up to 90%
- 600mA Output Current
- 0.6V Minimum Output Voltage
- 2.5V to 5.5V Input Voltage Range
- <1μA Shutdown Current
- Pulse Skipping Mode Operation
- Thermal Fault Protection

#### Typical Application Circuit

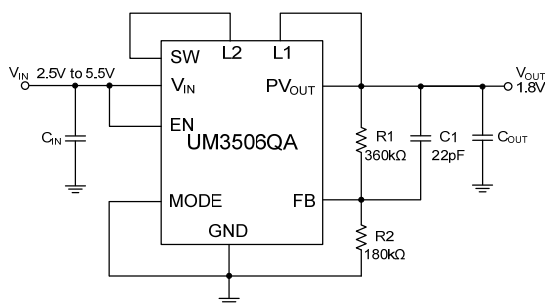

#### Light Load Efficiency

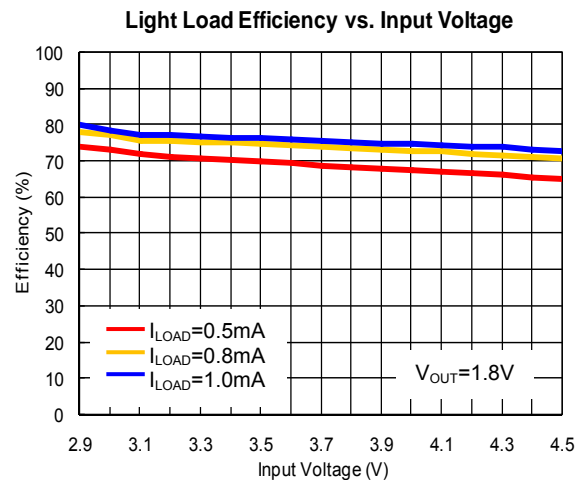

## Pin Configurations

## Top View

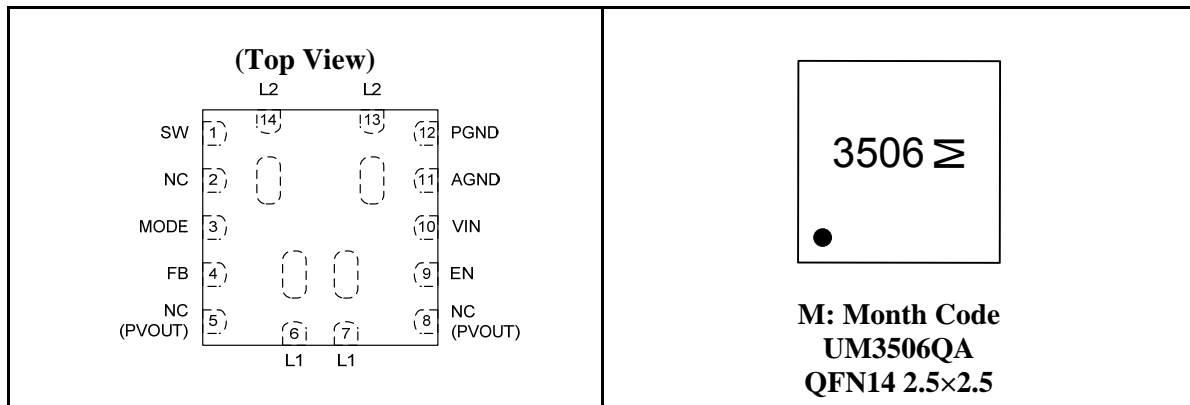

## Pin Description

Pin Number	Symbol	Function
1	SW	This pin is the common switching node of the internal MOSFETs. It is usually connected to L2 in the PCB.
2	NC	Not internally connected, can be connected to any other network in the PCB.
3	MODE	MODE pin=high forces the device to operate in fixed-frequency PWM mode. Mode pin=low enables automatic transition from the pulse skipping mode to fixed-frequency PWM mode.
4	FB	Feedback input pin. Connect FB to the center point of the external resistor divider.
5, 8	NC (PVOOUT)	Not internally connected, usually connected to power output in the PCB.
6, 7	L1	These pins are connected together inside and usually connected to NC(PVOOUT) in the PCB.
9	EN	Regulator enable control input. Pulling this pin to high enables the device. Pulling this pin to low forces the device into shutdown mode. This pin must be terminated.
10	VIN	Power input for the MOSFET switches. Must be closely decoupled to GND with a 4.7μF or greater ceramic capacitor.
11	AGND	Analog ground. This is the ground for the internal control circuitry, and the ground return for external feedback voltage divider. It must be connected to the quiet point of the ground.
12	PGND	Power ground. Connect this pin to the ground electrode of the input and output filter capacitors closely.
13, 14	L2	These pins are connected together inside and usually connected to SW in the PCB.

## Ordering Information

Part Number	Packaging Type	Marking Code	Shipping Qty
UM3506QA	QFN14 2.5×2.5	3506	3000pcs/13Inch Tape & Reel

## Absolute Maximum Ratings (Note 1)

Symbol	Parameter	Value	Unit
$V_{IN}, V_{OUT}$	Input and Output Voltages	-0.3 to +6.0	V
$V_{EN}, V_{FB}$	EN, FB Voltages	-0.3 to $V_{IN}+0.3$	V
$V_{SW}$	SW Voltage	-0.3 to $V_{IN}+0.3$	V
$I_{SW}$	Peak SW Sink and Source Current	1.5	A
$T_O$	Operating Temperature	-40 to +85	°C
$T_{STG}$	Storage Temperature Range	-65 to +150	°C
$T_{REFLOW}$	Reflow Temperature, MSL3 JEDEC J-STD-020C, 10 Sec	260	°C

Note 1: Stresses greater than those listed under Maximum Ratings may cause permanent damage to the device. This is a stress rating only and functional operation of the device at these or any other conditions above those indicated in the operational sections of this specification is not implied. Exposure to absolute maximum rating conditions for extended periods may affect reliability.

## Electrical Characteristics (Note 2)

( $V_{IN}=V_{EN}=3.6V$ ,  $T_A=+25^{\circ}C$ ,  $C_{IN}=4.7\mu F$ ,  $C_{OUT}=10\mu F$ , unless otherwise noted)

Symbol	Parameter	Test Conditions	Min	Typ	Max	Unit
$V_{IN}$	Input Voltage Range		2.5		5.5	V
$V_{OUT}$	Output Voltage Range		0.6		5	V
$I_{O(max)}$	Maximum Output Current		600			mA
$I_Q$ (Active)	Input DC Supply Current (Active Mode)	$V_{FB}=0.6V$ , $I_{LOAD}=0A$		60		$\mu A$
$I_Q$ (Shutdown)	Input DC Supply Current (Shutdown Mode)	$V_{EN}=0V$		0.1	1.0	$\mu A$
$V_{FB}$	Feedback Voltage		0.5880	0.6000	0.6120	V
		$T_A=-40^{\circ}C\sim 85^{\circ}C$	0.5830	0.6000	0.6150	
$I_{FB}$	FB Input Bias Current	$V_{FB}=0.65V$			$\pm 30$	nA
f	Oscillator Frequency	$V_{FB}=0.6V$ or $V_{OUT}=100\%$		2.25		MHz
$R_{DS(ON)}$	$R_{DS(ON)}$ of P-CH MOSFET	$V_{IN}=3.6V$ , $I_{SW}=100mA$		0.3		$\Omega$
	$R_{DS(ON)}$ of N-CH MOSFET	$V_{IN}=3.6V$ , $I_{SW}=-100mA$		0.2		$\Omega$
	Internal Inductor DCR			0.2		$\Omega$
$I_{SWL}$	SW Leakage	$V_{EN}=0V$ , $V_{IN}=5V$ , $V_{SW}=0V$ or $5V$		$\pm 0.01$	$\pm 1$	$\mu A$
$V_H$	EN High-Level Threshold	$-40^{\circ}C\leq T_A\leq 85^{\circ}C$	1.0			V
$V_L$	EN Low-Level Threshold	$-40^{\circ}C\leq T_A\leq 85^{\circ}C$			0.4	V
$I_{ENL}$	EN Leakage Current			$\pm 0.1$	$\pm 1$	$\mu A$
	Thermal Shutdown Temperature			160		°C
	Thermal Shutdown Trip Point Hysteresis			25		°C

Note2: 100% production test at +25°C. Specifications over the temperature range are guaranteed by design and characterization.

## Typical Performance Characteristics

( $V_{IN}=3.6V$ ,  $V_{OUT}=1.8V$ ,  $C_{IN}=4.7\mu F$ ,  $C_{OUT}=10\mu F$ ,  $T_A=+25^\circ C$ , unless otherwise noted.)

### Efficiency vs. Load Current

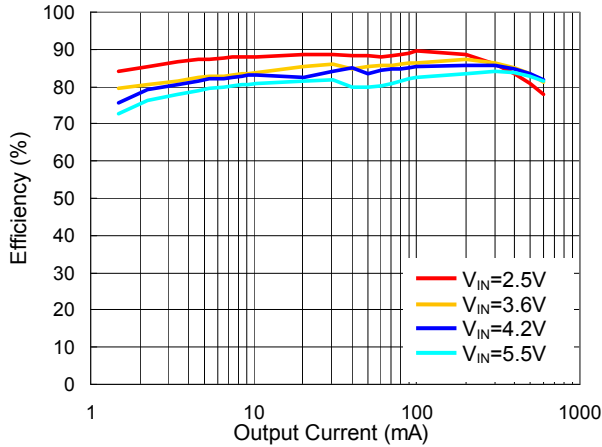

### Efficiency vs. Input Voltage

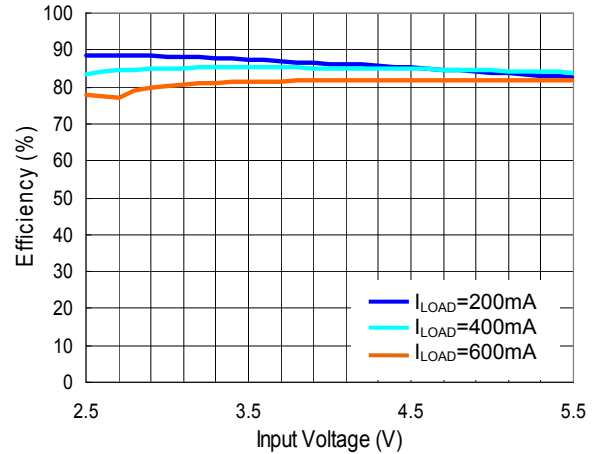

### Output Voltage vs. Load Current

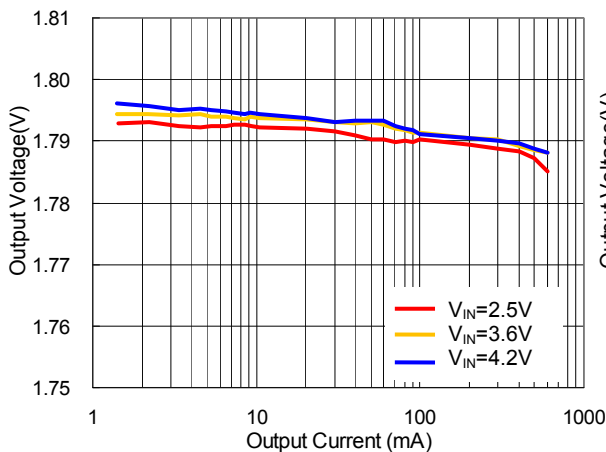

### Output Voltage vs. Input Voltage

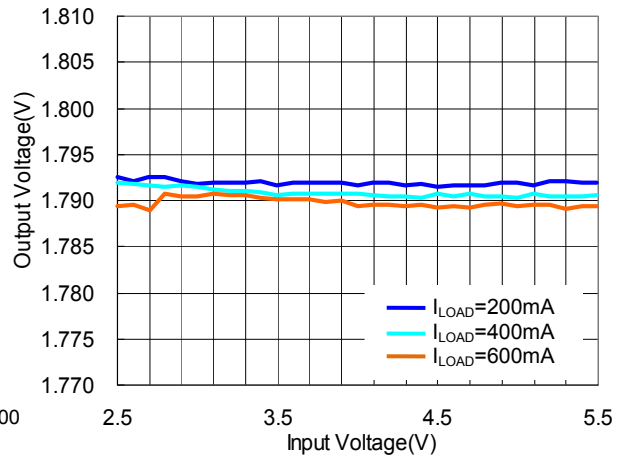

### Supply Current vs. Input Voltage

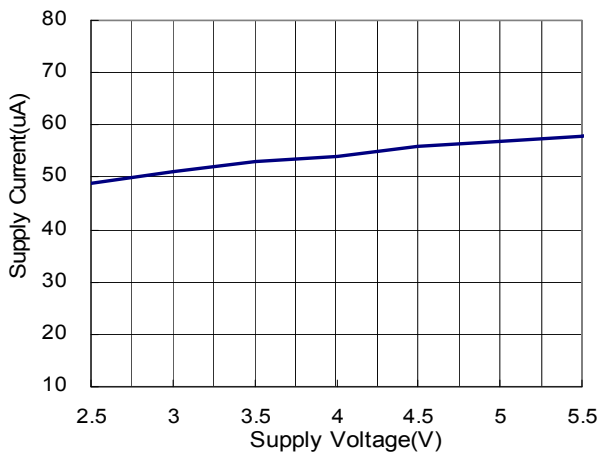

### Start-up from Shutdown ( $I_{OUT}=300mA$ )

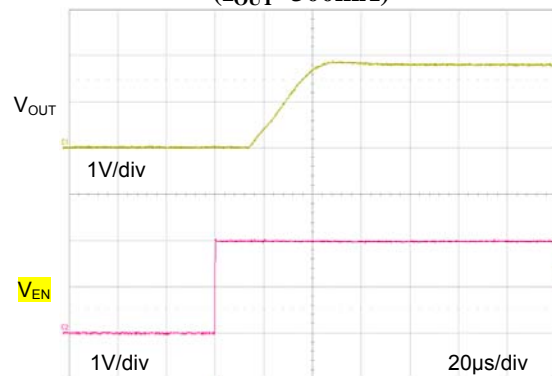

## Typical Performance Characteristics (Continued)

( $V_{IN}=3.6V$ ,  $V_{OUT}=1.8V$ ,  $C_{IN}=4.7\mu F$ ,  $C_{OUT}=10\mu F$ ,  $T_A=+25^\circ C$ , unless otherwise noted.)

**Line Transient Response**  
( $V_{IN}=3.5V$  to  $4.5V$ ,  $I_{OUT}=300mA$ )

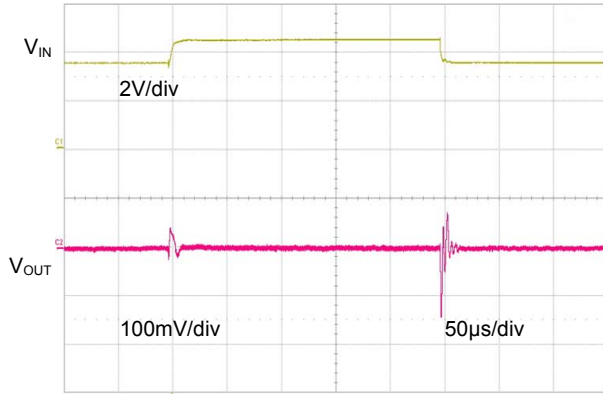

**Load Transient Response**  
( $V_{IN}=3.5V$ ,  $I_{OUT}=100mA$  to  $450mA$ )

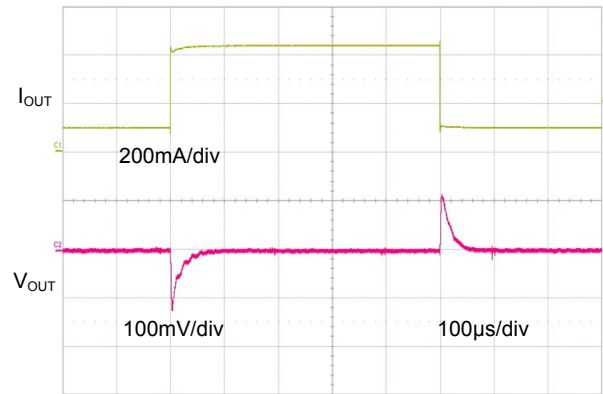

**Pulse Skipping Mode Operation**  
( $I_{OUT}=1mA$ )

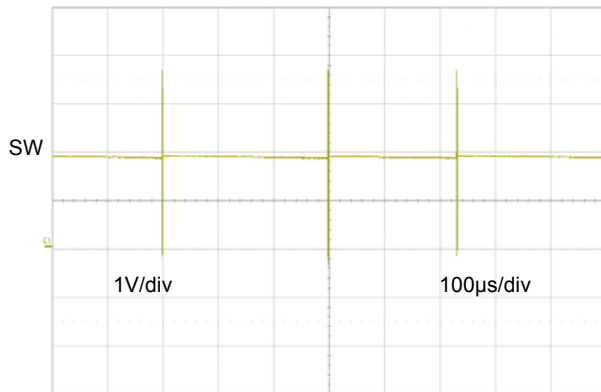

**Normal Operation**  
( $I_{OUT}=100mA$ )

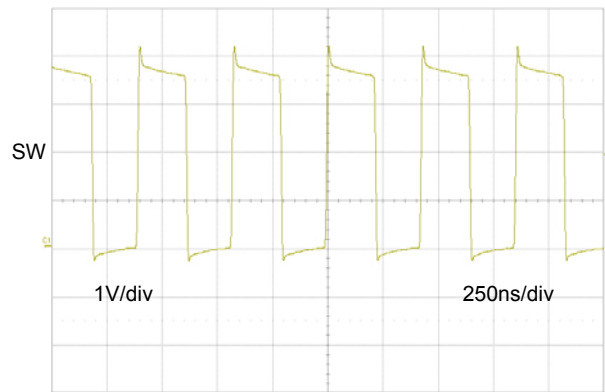

**Ripple and HF Noise**  
( $I_{OUT}=300mA$ )

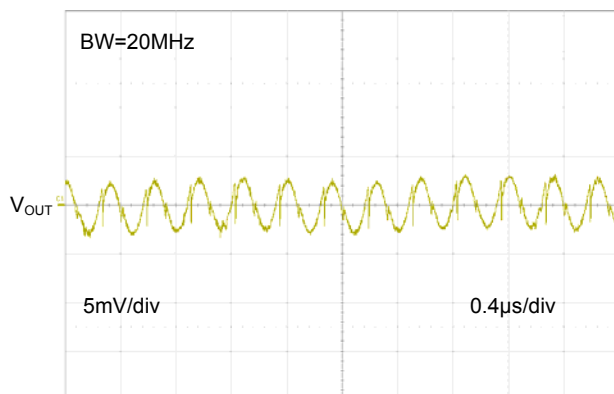

**Ripple and HF Noise**  
( $I_{OUT}=300mA$ )

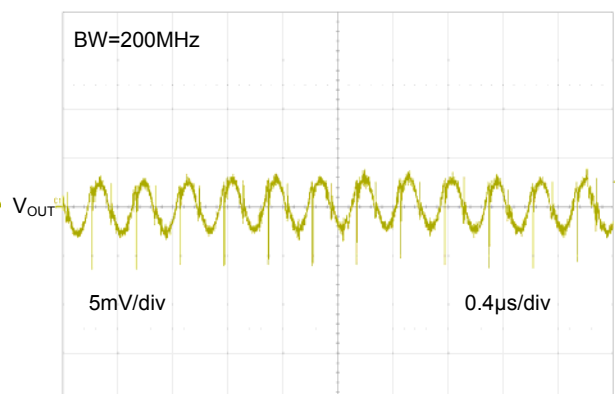

## Block Diagram

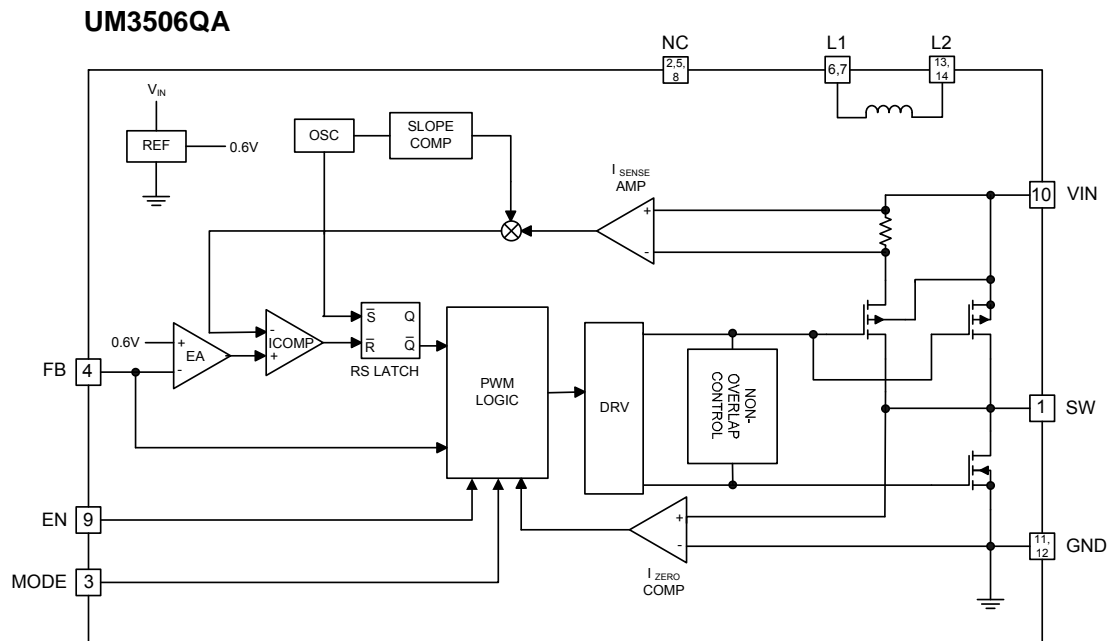

## Function Description

### Integrated Inductor

The UM3506QA utilizes a low loss, multilayer inductor. The DCR of the integrated inductor is 180mΩ and the inductance is about 2.2μH. The use of an internal inductor localizes the noise associated with the output loop currents. The proprietary integrated inductor construction reduces the area of the converter's large current loop that can reduce the radiated noise coupled into the traces of the circuit board. Furthermore, the package layout is optimized to reduce the electrical path length for the AC ripple currents that is a major source of radiated emissions from DC-DC converters. The integrated inductor significantly reduces parasitic effects that can harm loop stability, and makes layout very simple. All these lead to lower output noise and fewer influences on the input power.

### Current Mode PWM Control and Current Limit

The UM3506QA uses constant frequency, current mode step-down architecture. Both the main (P-channel MOSFET) and synchronous (N-channel MOSFET) switches are internal. From the block diagram, a comparator ICOMP is used to realize current limit protection. Lossless current sensing converts the peak current signal to a voltage to sum in with the internal slope compensation. This summed signal is compared to the error amplifier output to provide a peak current control command for the PWM. The cycle-by-cycle current limit is set at 1200mA (typical). During normal operation, the internal top power MOSFET is turned on each cycle when the oscillator sets the RS latch, and turned off when the current comparator ICOMP, resets the RS latch. The peak inductor current at which ICOMP resets the RS latch, is controlled by the output of error amplifier EA. When the load current increases, it causes a slight decrease in the feedback voltage, FB, relative to the 0.6V reference, which in turn, causes the EA amplifier's output voltage to increase until the average inductor current matches the new load current. While the top MOSFET is off, the bottom MOSFET is turned on until either the inductor current starts to

reverse, as indicated by the current reversal comparator  $I_{ZERO}$ , or the beginning of the next clock cycle.

When the output is shorted to ground, the inductor current may exceed the maximum inductor peak current if not allowed enough time to decay. To prevent the inductor current from running away, the bottom N-channel MOSFET is allowed to stay on for more than one cycle, thereby allowing the inductor current time to decay.

### **Pulse Skipping Mode Operation**

At very light loads, the UM3506QA automatically enters Pulse Skipping Mode. In the Pulse Skipping Mode, the inductor current may reach zero or reverse on each pulse. The PWM control loop will automatically skip pulses to maintain output regulation. The bottom MOSFET is turned off by the current reversal comparator,  $I_{ZERO}$ , and the switch voltage will ring. This is discontinuous mode operation, and is normal behavior for the switching regulator.

### **Enable**

The EN pin provides a means to shut down the converter or enable normal operation. A logic low will disable the converter and cause it to shut down. A logic high will enable the converter into normal operation. In shutdown mode, the device quiescent current will be less than  $1\mu\text{A}$ . The EN pin must not be left floating.

### **Thermal Shutdown**

When excessive power is dissipated in the chip, the junction temperature rises. Once the junction temperature exceeds the thermal shutdown temperature, the thermal shutdown circuit turns off the converter's output voltage thus allowing the device to cool. When the junction temperature decreases by  $25^{\circ}\text{C}$ , the device will go through the normal startup process.

## Package Information

### UM3506QA: QFN14 2.5×2.5

#### Outline Drawing

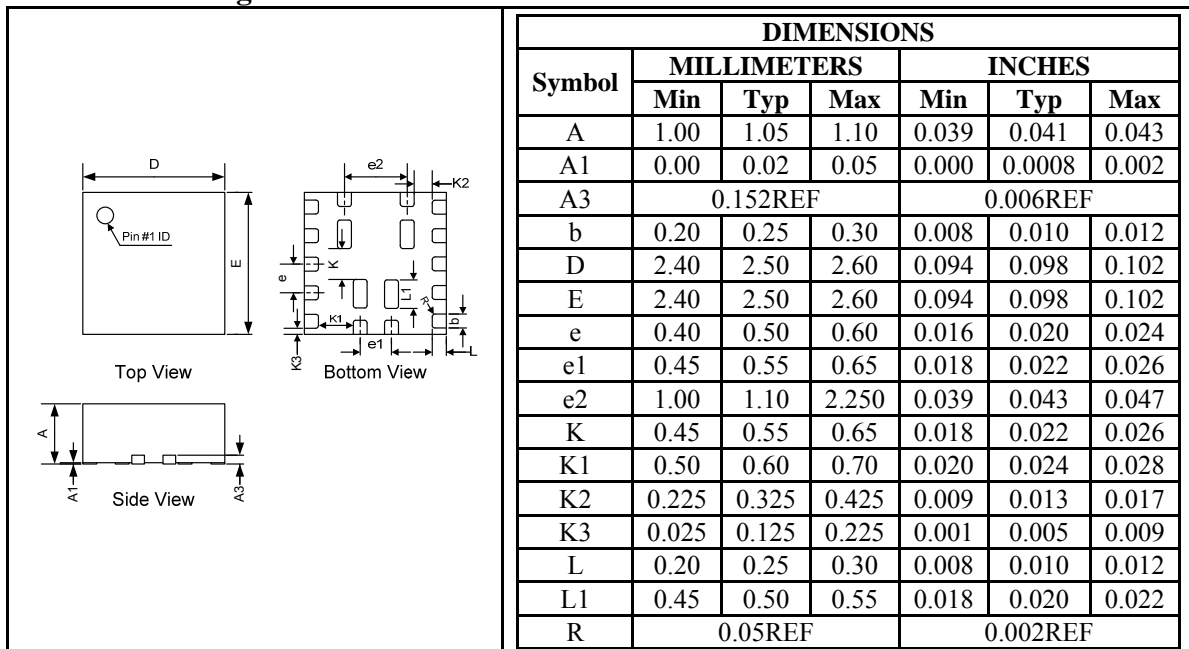

#### Land Pattern

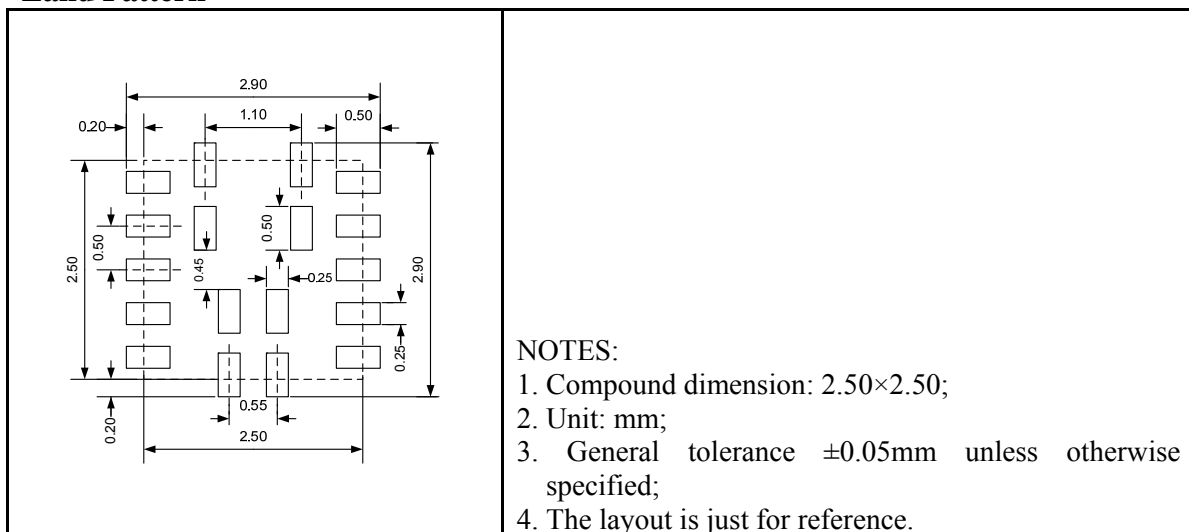

#### Tape and Reel Orientation





---

## GREEN COMPLIANCE

Union Semiconductor is committed to environmental excellence in all aspects of its operations including meeting or exceeding regulatory requirements with respect to the use of hazardous substances. Numerous successful programs have been implemented to reduce the use of hazardous substances and/or emissions.

All Union components are compliant with the RoHS directive, which helps to support customers in their compliance with environmental directives. For more green compliance information, please visit:

[http://www.union-ic.com/index.aspx?cat\\_code=RoHSDeclaration](http://www.union-ic.com/index.aspx?cat_code=RoHSDeclaration)

## IMPORTANT NOTICE

The information in this document has been carefully reviewed and is believed to be accurate. Nonetheless, this document is subject to change without notice. Union assumes no responsibility for any inaccuracies that may be contained in this document, and makes no commitment to update or to keep current the contained information, or to notify a person or organization of any update. Union reserves the right to make changes, at any time, in order to improve reliability, function or design and to attempt to supply the best product possible.