

300mA, Micropower, VLDO Linear Regulator

UM365xxS SOT23-3

UM365xxP SOT323

General Description

The UM365xx series are VLDO (very low dropout) linear regulators designed for low power portable applications. Maximum dropout is just 200mV at the load current of 100mA. The internal P-channel MOSFET pass transistor requires no base current, allowing the device to draw only 90µA during normal operation at the maximum load current of 300mA.

Other features include high output voltage accuracy, under voltage lockout, stability with ultra low ESR ceramic capacitors as small as 1µF, thermal overload protection and output current limiting. The UM365xx series are available in a low profile SOT23-3 or SOT323 package.

Applications

- Bluetooth/802.11 Cards
- PDAs and Notebook Computers
- Portable Instruments and Battery-Powered Systems
- Cellular Phones

Features

- Very Low Dropout: 200mV (Max) at 100mA
- Maximum Input Voltage: 6.0V
- Low Noise: 200µV_{RMS} (10Hz to 100kHz)
- ±2% Voltage Accuracy at 150mA
- Fixed Output Voltage:
1.2V to 5.0V with 100mV Interval
- Output Current Limit
- Stable with 1µF Output Capacitor
- Thermal Overload Protection
- Low Profile SOT23-3 or SOT323 Package

Pin Configurations

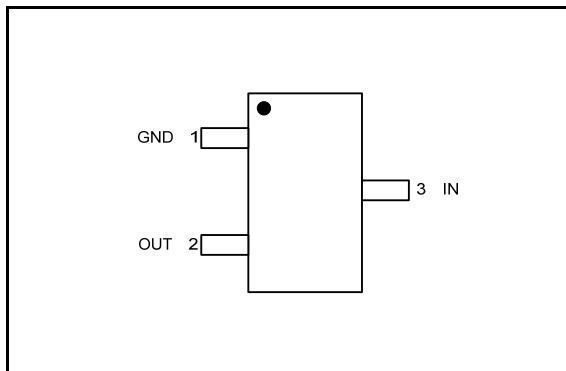

Top View

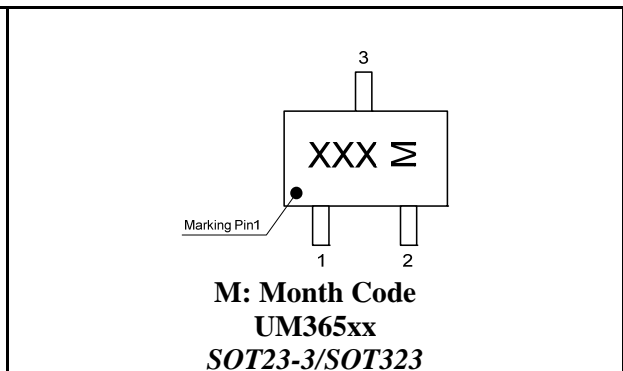

Pin Description

Pin Number	Symbol	Function
1	GND	Ground
2	OUT	Voltage Regulated Output
3	IN	Power Supply

Ordering Information

Part Number	Output Voltage	Packaging Type	Marking Code	Shipping Qty
UM36512S	1.2V	SOT23-3	52D	3000pcs/7Inch Tape & Reel
UM36513S	1.3V		52E	
UM36514S	1.4V		52H	
UM36515S	1.5V		52J	
UM36516S	1.6V		52L	
UM36517S	1.7V		52M	
UM36518S	1.8V		52K	
UM36519S	1.9V		52F	
UM36520S	2.0V		52B	
UM36521S	2.1V		52A	
UM36522S	2.2V		U2C	
UM36523S	2.3V		U23	
UM36524S	2.4V		U24	
UM36525S	2.5V		52N	
UM36526S	2.6V		U26	
UM36527S	2.7V		52P	
UM36528S	2.8V		52Q	
UM36529S	2.9V		U29	
UM36530S	3.0V		52R	
UM36531S	3.1V		52S	
UM36532S	3.2V		52T	
UM36533S	3.3V		53U	
UM36534S	3.4V		52Y	
UM36535S	3.5V		53Z	
UM36536S	3.6V		54L	
UM36537S	3.7V		U47	
UM36538S	3.8V		54K	
UM36539S	3.9V		U49	
UM36540S	4.0V		54R	
UM36541S	4.1V		54A	
UM36542S	4.2V	U4D		
UM36543S	4.3V	U4E		
UM36544S	4.4V	U44		
UM36545S	4.5V	54J		
UM36546S	4.6V	54N		
UM36547S	4.7V	54P		
UM36548S	4.8V	54Q		
UM36549S	4.9V	54H		
UM36550S	5.0V	U4F		

Ordering Information (Continued)

Part Number	Output Voltage	Packaging Type	Marking Code	Shipping Qty
UM36512P	1.2V	SOT323	VS2	3000pcs/7Inch Tape & Reel
UM36513P	1.3V		VS3	
UM36514P	1.4V		VS4	
UM36515P	1.5V		VS5	
UM36516P	1.6V		VS6	
UM36517P	1.7V		VS7	
UM36518P	1.8V		VS8	
UM36519P	1.9V		VS9	
UM36520P	2.0V		VSA	
UM36521P	2.1V		VSB	
UM36522P	2.2V		VR2	
UM36523P	2.3V		VR3	
UM36524P	2.4V		VR4	
UM36525P	2.5V		VR5	
UM36526P	2.6V		VR6	
UM36527P	2.7V		VR7	
UM36528P	2.8V		VR8	
UM36529P	2.9V		VR9	
UM36530P	3.0V		VRA	
UM36531P	3.1V		VRB	
UM36532P	3.2V		VZ2	
UM36533P	3.3V		VZ3	
UM36534P	3.4V		VZ4	
UM36535P	3.5V		VZ5	
UM36536P	3.6V		VZ6	
UM36537P	3.7V		VZ7	
UM36538P	3.8V		VZ8	
UM36539P	3.9V		VZ9	
UM36540P	4.0V		VZA	
UM36541P	4.1V		VZB	
UM36542P	4.2V	ZL2		
UM36543P	4.3V	ZL3		
UM36544P	4.4V	ZL4		
UM36545P	4.5V	ZL5		
UM36546P	4.6V	ZL6		
UM36547P	4.7V	ZL7		
UM36548P	4.8V	ZL8		
UM36549P	4.9V	ZL9		
UM36550P	5.0V	ZLA		

Absolute Maximum Ratings (Note 1)

Symbol	Parameter	Value	Unit
V _{IN}	Supply Voltage on IN Pin	-0.3 to +7.5	V
V _{OUT}	Voltage on OUT Pin	-0.3 to +7.5	V
T _J	Operating Junction Temperature (Note 2, 3)	-40 to +125	°C
T _{STG}	Storage Temperature Range	-65 to +150	°C
T _L	Lead Temperature for Soldering 10 Seconds	+300	°C

Note 1: Absolute Maximum Ratings are those values beyond which the life of a device may be impaired.

Note 2: The UM365xx is tested and specified under pulse load conditions such that $T_J \approx T_A$. The device is guaranteed to meet performance specifications from 0°C to 70°C. Specifications over the -40°C to 125°C operating junction temperature range are assured by design, characterization and correlation with statistical process controls.

Note 3: This IC includes overtemperature protection that is intended to protect the device during momentary overload conditions. Junction temperature will exceed 125°C when overtemperature protection is active. Continuous operation above the specified maximum operating junction temperature may impair device reliability.

Electrical Characteristics
 $V_{CC}=V_{OUT}+1V$ ($V_{OUT}\geq 1.5V$) or $V_{CC}=2.5V$ ($V_{OUT}\leq 1.5V$), $T_A=-40^{\circ}C$ to $+85^{\circ}C$.

Symbol	Parameter	Test Conditions	Min	Typ	Max	Unit
V_{IN}	Input Voltage Range		2.5		6	V
V_{OUT}	Output Voltage Range		1.2		5.0	V
I_Q	Operating Quiescent Current	$I_{OUT}=0mA$		50	120	μA
		$I_{OUT}=300mA$		90	130	
I_{OUT}	Output Current		300			mA
	Output Voltage Accuracy	$1mA\leq I_{OUT}\leq 300mA$, $T_A=-40^{\circ}C$ to $+85^{\circ}C$	-2.5		+2.5	%
ΔV_{DO}	Dropout Voltage	$I_{OUT}=100mA$		150	200	mV
I_{LIMIT}	Output Current Limit		330	450	700	mA
	Output Voltage TC			100		ppm/ $^{\circ}C$
T_{SHDN}	Thermal-Shutdown Temperature			160		$^{\circ}C$
ΔT_{SHDN}	Thermal-Shutdown Hysteresis			35		$^{\circ}C$
	Line Regulation ($V_{OUT}>4.0V$)	$V_{OUT}+0.3V\leq V_{IN}\leq 6.0V$ or $V_{IN}>2.5V$ $I_{OUT}=10mA$			0.5	%/ V
	Line Regulation ($V_{OUT}\leq 4.0V$)				0.3	
	Load Regulation ($V_{OUT}>4.0V$)	$V_{IN}=V_{OUT}+1V$ or $V_{IN}>2.5V$ $1mA\leq I_{OUT}\leq 300mA$			1.2	%
	Load Regulation ($V_{OUT}\leq 4.0V$)				0.6	
	Output Voltage Noise	10Hz to 100KHz $C_{IN}=1\mu F$, $I_{OUT}=10mA$		200		μV_{RMS}
PSRR	Power Supply Ripple Rejection ($V_{OUT}>4.0V$)	$V_{IN}=V_{OUT}+1V$ or $V_{IN}>2.5V$ $I_{OUT}=100mA$	$f=100Hz$	40		dB
			$f=10kHz$	30		
	Power Supply Ripple Rejection ($V_{OUT}\leq 4.0V$)		$f=100Hz$	60		
			$f=10kHz$	30		
	ESD Rating	Human Body Mode	2			kV

Typical Performance Characteristics

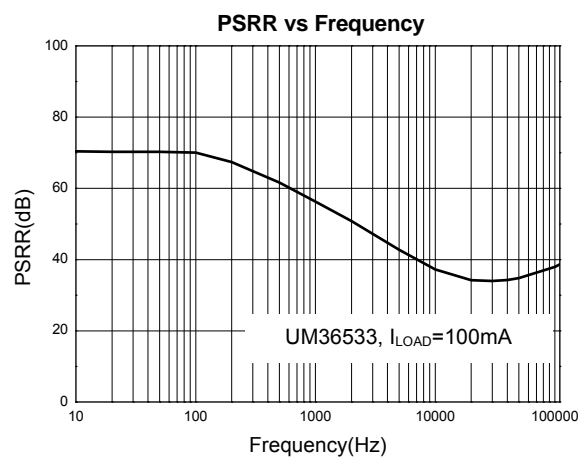
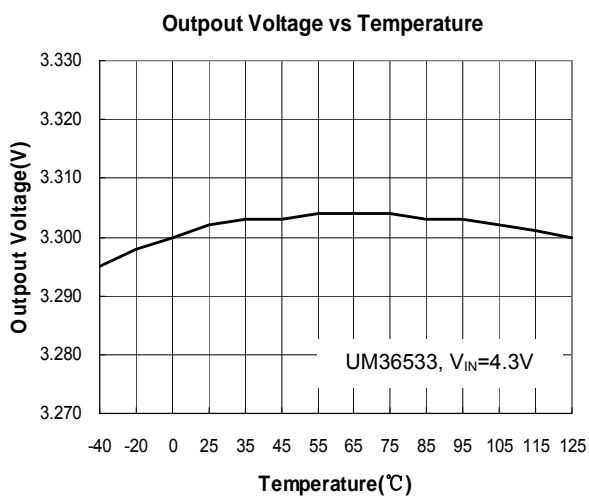
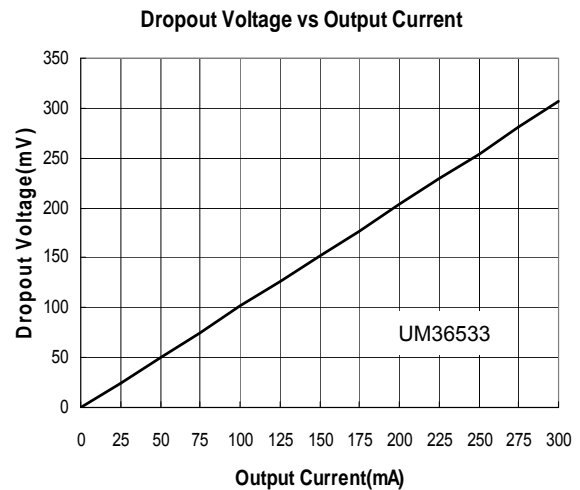
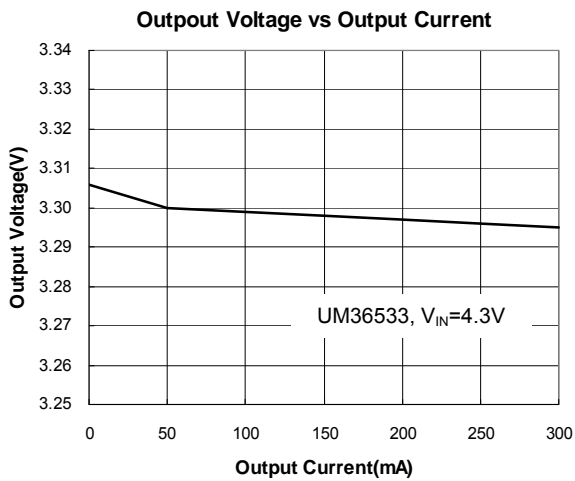
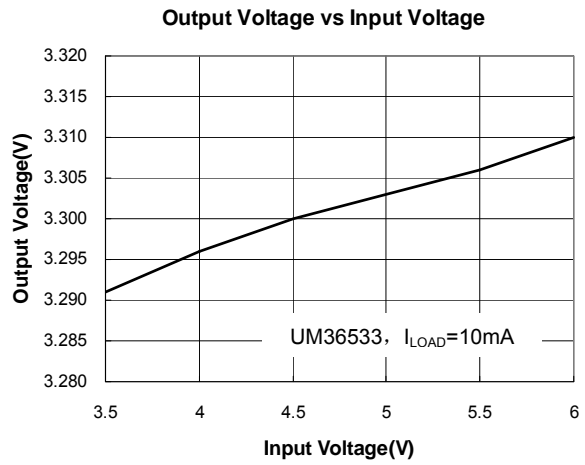
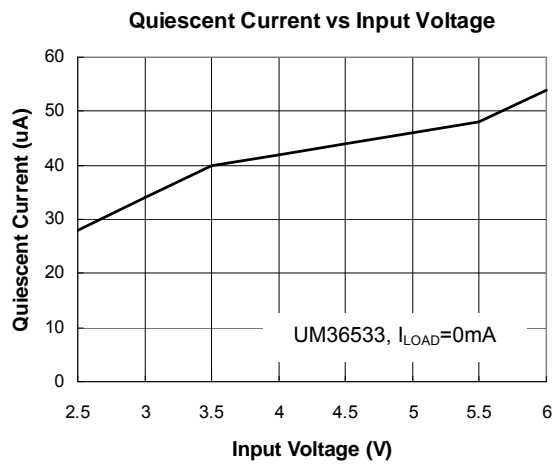

Typical Performance Characteristics (Continued)

Line Transient Response

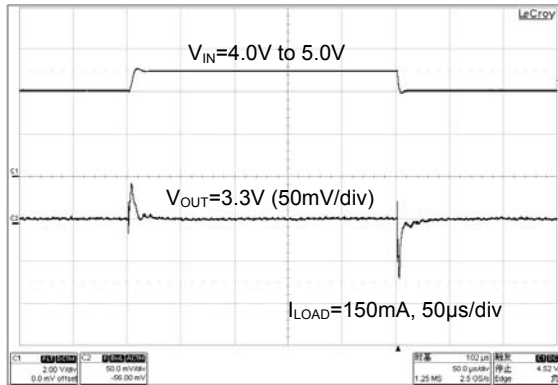

Load Transient Response

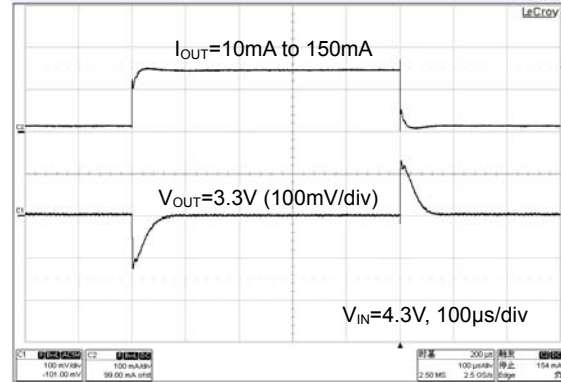

Pin Function

GND (Pin 1): Ground and Heat Sink. Solder to a ground plane or large pad to maximize heat dissipation.

OUT (Pin 2): Voltage Regulated Output. The OUT pin supplies power to the load. A minimum output capacitor of $1\mu\text{F}$ is required to ensure stability. Larger output capacitors may be required for applications with large transient loads to limit peak voltage transients.

IN (Pin 3): Power for UM365xx and Load Power is supplied to the devices through the IN pin. The IN pin should be locally bypassed to ground if the UM365xx series are more than a few inches away from another source of bulk capacitance. In general, the output impedance of a battery rises with frequency, so it is usually advisable to include an input bypass capacitor in battery-powered circuits. A capacitor in the range of $0.1\mu\text{F}$ to $1\mu\text{F}$ is usually sufficient.

Typical Application Circuit

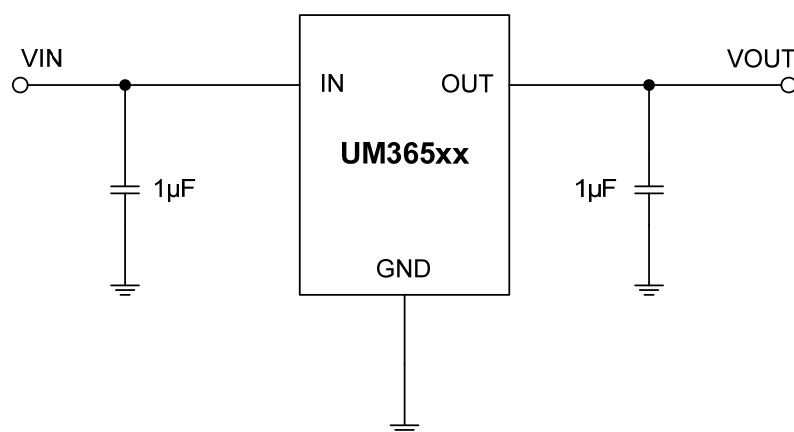

Package Information

UM365xxS: SOT23-3

Outline Drawing

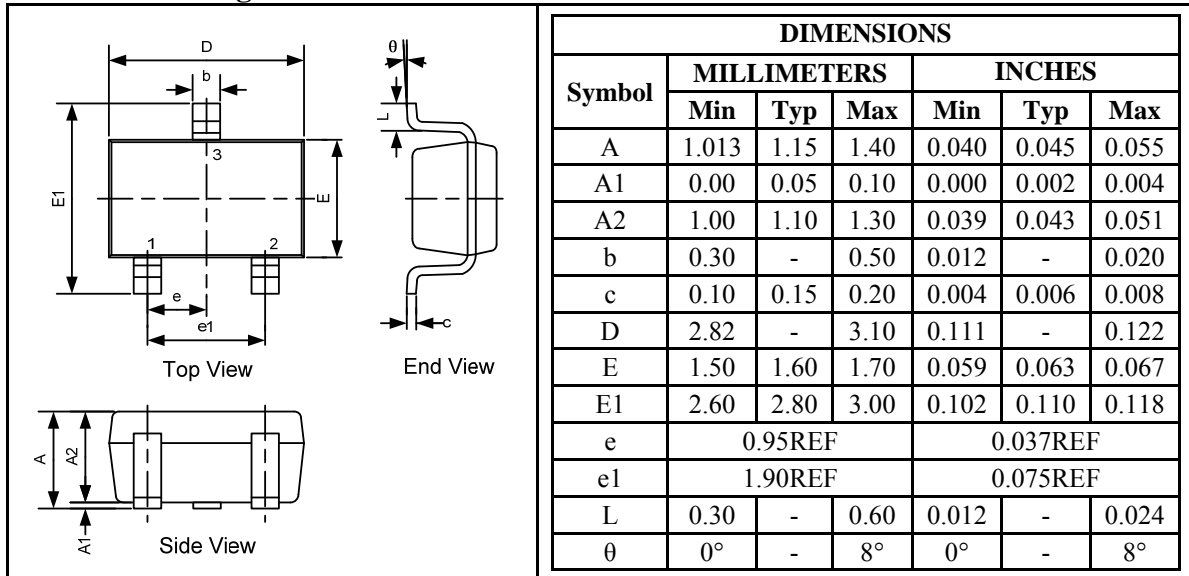

Land Pattern

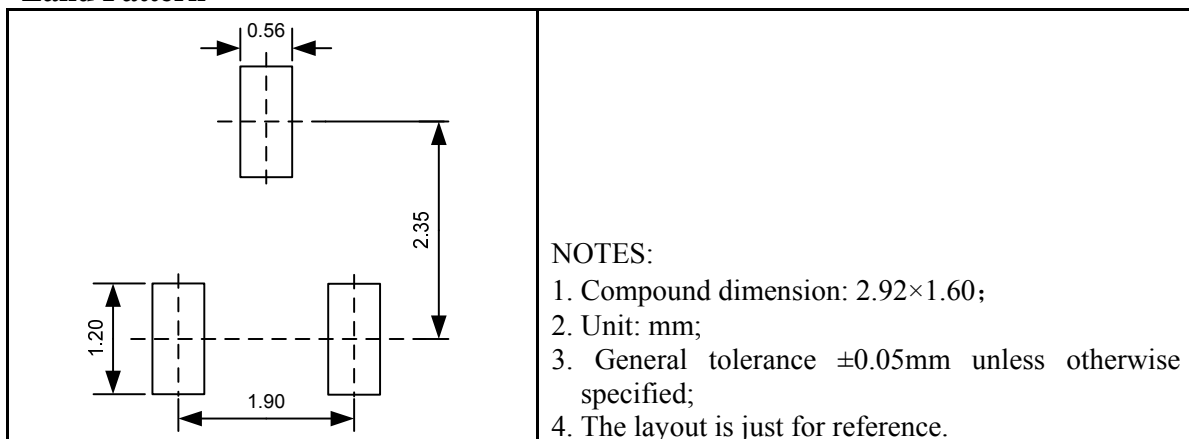

Tape and Reel Orientation



UM365xxP: SOT323

Outline Drawing

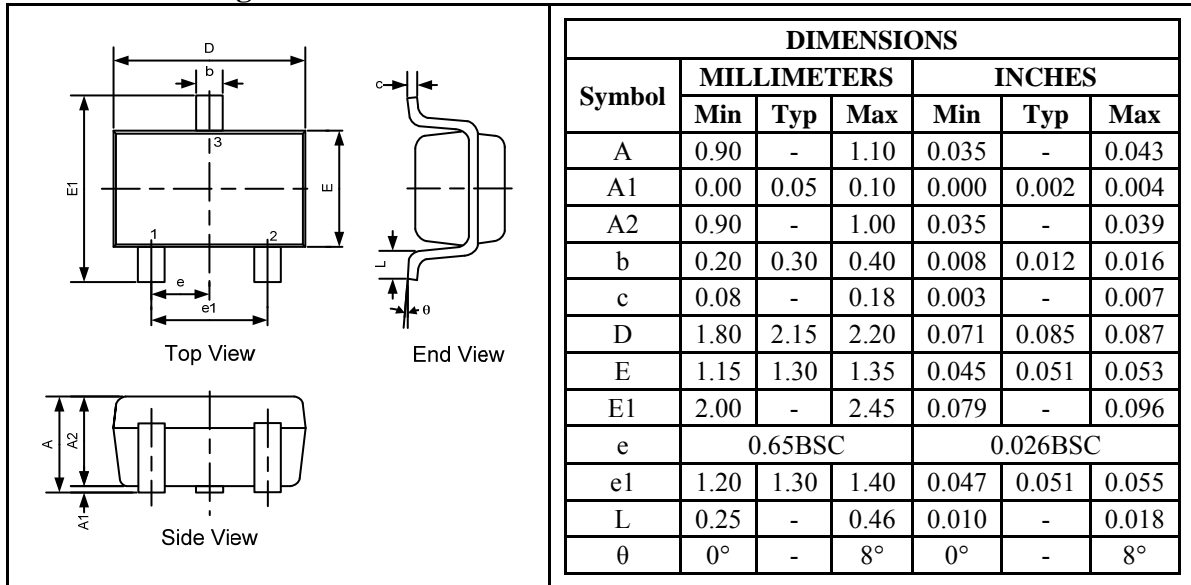

Land Pattern

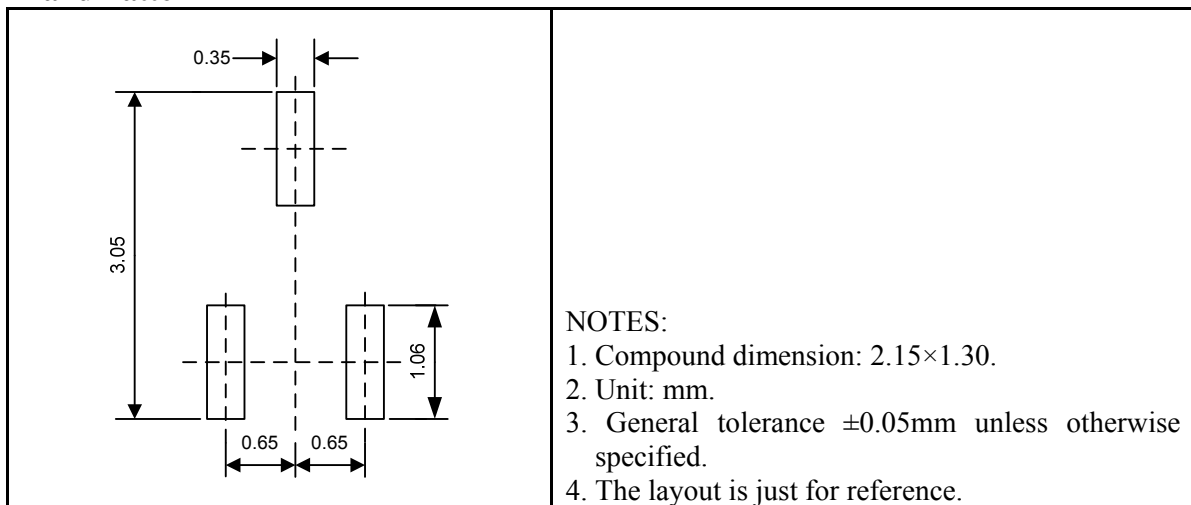

Tape and Reel Orientation



GREEN COMPLIANCE

Union Semiconductor is committed to environmental excellence in all aspects of its operations including meeting or exceeding regulatory requirements with respect to the use of hazardous substances. Numerous successful programs have been implemented to reduce the use of hazardous substances and/or emissions.

All Union components are compliant with the RoHS directive, which helps to support customers in their compliance with environmental directives. For more green compliance information, please visit:

http://www.union-ic.com/index.aspx?cat_code=RoHSDeclaration

IMPORTANT NOTICE

The information in this document has been carefully reviewed and is believed to be accurate. Nonetheless, this document is subject to change without notice. Union assumes no responsibility for any inaccuracies that may be contained in this document, and makes no commitment to update or to keep current the contained information, or to notify a person or organization of any update. Union reserves the right to make changes, at any time, in order to improve reliability, function or design and to attempt to supply the best product possible.



Union Semiconductor, Inc

Add: Unit 606, No.570 Shengxia Road, Shanghai 201210

Tel: 021-51093966

Fax: 021-51026018

Website: www.union-ic.com