

300mA, Micropower, VLDO Linear Regulator

UM375xxS SOT23-5

UM375xxP SOT353

General Description

The UM375xx series are VLDO (very low dropout) linear regulators designed for low power portable applications. Typical output noise is only $170\mu\text{V}_{\text{RMS}}$ (UM37512) and maximum dropout is just 200mV at the load current of 100mA. The internal P-channel MOSFET pass transistor requires no base current, allowing the device to draw only $90\mu\text{A}$ during normal operation at the maximum load current of 300mA.

Other features include high output voltage accuracy, under voltage lockout, stability with ultra low ESR ceramic capacitors as small as $1\mu\text{F}$, thermal overload protection and output current limiting. The UM375xx series are available in a low profile SOT23-5 and SOT353 package.

Applications

- Bluetooth/802.11 Cards
- PDAs and Notebook Computers
- Portable Instruments and Battery-Powered Systems
- Cellular Phones

Features

- Input Voltage Range: 2.0V to 6.0V
- Very Low Dropout: 200mV (Max) at 100mA
- Low Noise: $170\mu\text{V}_{\text{RMS}}$ (UM37512, 10Hz to 100kHz)
- $\pm 2\%$ Voltage Accuracy at 150mA
- Fixed Output Voltage: 1.2V to 5.0V with 100mV Interval
- Output Current Limit
- Stable with $1\mu\text{F}$ Output Capacitor
- Thermal Overload Protection
- Low Profile SOT23-5 and SOT353 Packages

Pin Configurations

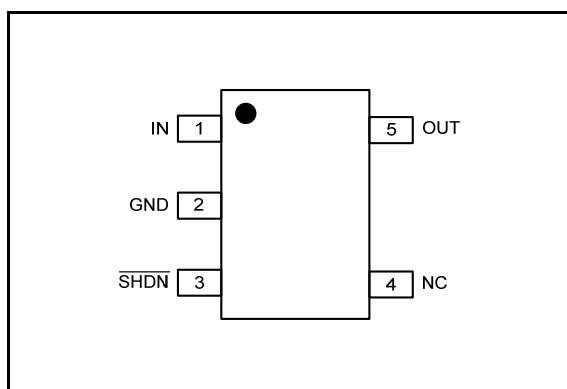

Top View

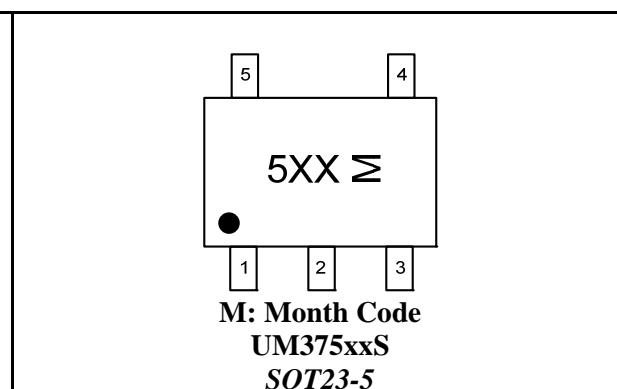

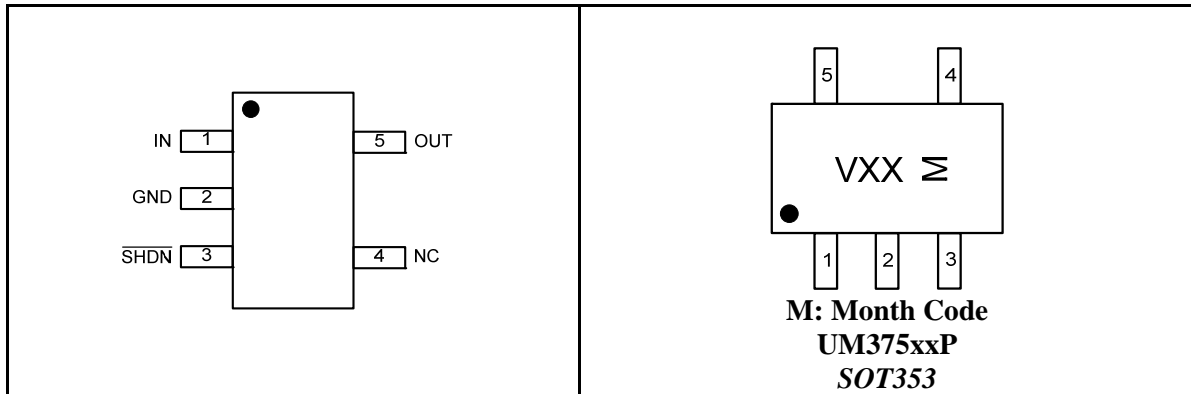

Pin Description

Pin Number	Symbol	Function
1	IN	Power Supply
2	GND	Ground
3	$\overline{\text{SHDN}}$	Shutdown Input, Active Low
4	NC	Not Connected
5	OUT	Voltage Regulated Output

Ordering Information

Part Number	Output Voltage	Packaging Type	Marking Code	Shipping Qty
UM37512S	1.2V	SOT23-5	5ED	3000pcs/7Inch Tape & Reel
UM37513S	1.3V		5EE	
UM37514S	1.4V		5EH	
UM37515S	1.5V		5EJ	
UM37516S	1.6V		5EL	
UM37517S	1.7V		5EM	
UM37518S	1.8V		5EK	
UM37519S	1.9V		5EF	
UM37520S	2.0V		5EC	
UM37521S	2.1V		5ES	
UM37522S	2.2V		5ET	
UM37523S	2.3V		5EY	
UM37524S	2.4V		5EU	
UM37525S	2.5V		5EN	
UM37526S	2.6V		5EZ	
UM37527S	2.7V		5EP	
UM37528S	2.8V		5EQ	
UM37529S	2.9V		5EB	
UM37530S	3.0V		5ER	
UM37531S	3.1V		5EA	
UM37532S	3.2V		5DD	
UM37533S	3.3V		5DE	
UM37534S	3.4V		5DB	
UM37535S	3.5V		5DF	
UM37536S	3.6V		5DH	
UM37537S	3.7V		5DA	
UM37538S	3.8V		5DL	
UM37539S	3.9V		5DT	
UM37540S	4.0V		5DM	
UM37541S	4.1V		5DY	
UM37542S	4.2V	5DJ		
UM37543S	4.3V	5DN		
UM37544S	4.4V	5DV		
UM37545S	4.5V	5DP		
UM37546S	4.6V	5DZ		
UM37547S	4.7V	5DQ		
UM37548S	4.8V	5DR		
UM37549S	4.9V	5D9		
UM37550S	5.0V	5DS		

Ordering Information (Continued)

Part Number	Output Voltage	Packaging Type	Marking Code	Shipping Qty
UM37512P	1.2V	SOT353	VL2	3000pcs/7Inch Tape & Reel
UM37513P	1.3V		VL3	
UM37514P	1.4V		VL4	
UM37515P	1.5V		VL5	
UM37516P	1.6V		VL6	
UM37517P	1.7V		VL7	
UM37518P	1.8V		VL8	
UM37519P	1.9V		VL9	
UM37520P	2.0V		VLA	
UM37521P	2.1V		VM1	
UM37522P	2.2V		VM2	
UM37523P	2.3V		VM3	
UM37524P	2.4V		VM4	
UM37525P	2.5V		VM5	
UM37526P	2.6V		VM6	
UM37527P	2.7V		VM7	
UM37528P	2.8V		VM8	
UM37529P	2.9V		VM9	
UM37530P	3.0V		VMA	
UM37531P	3.1V		VJ1	
UM37532P	3.2V		VJ2	
UM37533P	3.3V		VJ3	
UM37534P	3.4V		VJ4	
UM37535P	3.5V		VJ5	
UM37536P	3.6V		VJ6	
UM37537P	3.7V		VJ7	
UM37538P	3.8V		VJ8	
UM37539P	3.9V		VJ9	
UM37540P	4.0V		VJA	
UM37541P	4.1V		VT1	
UM37542P	4.2V	VT2		
UM37543P	4.3V	VT3		
UM37544P	4.4V	VT4		
UM37545P	4.5V	VT5		
UM37546P	4.6V	VT6		
UM37547P	4.7V	VT7		
UM37548P	4.8V	VT8		
UM37549P	4.9V	VT9		
UM37550P	5.0V	VTA		

Absolute Maximum Ratings (Note 1)

Symbol	Parameter	Value	Unit
V _{IN}	Supply Voltage on IN Pin	-0.3 to +7.5	V
V _{OUT}	Voltage on OUT Pin	-0.3 to +7.5	V
T _J	Operating Junction Temperature (Note 2, 3)	-40 to +125	°C
T _{STG}	Storage Temperature Range	-65 to +150	°C
T _L	Lead Temperature for Soldering 10 Seconds	+300	°C
P _D (Note 4)	Power Dissipation @ 25°C	SOT23-5	0.6
		SOT353	0.55

Note 1: Absolute Maximum Ratings are those values beyond which the life of a device may be impaired.

Note 2: The UM375xx is tested and specified under pulse load conditions such that $T_J \approx T_A$. The device is guaranteed to meet performance specifications from 0°C to 70°C. Specifications over the -40°C to 125°C operating junction temperature range are assured by design, characterization and correlation with statistical process controls.

Note 3: This IC includes overtemperature protection that is intended to protect the device during momentary overload conditions. Junction temperature will exceed 125°C when overtemperature protection is active. Continuous operation above the specified maximum operating junction temperature may impair device reliability.

Note 4: The maximum allowable power dissipation of any T_A (ambient temperature) is $P_{D\text{MAX}} = (T_{J\text{MAX}} - T_A) / \theta_{JA}$. Exceeding the maximum allowable power dissipation will result in excessive die temperature and the regulator will go into thermal shutdown.

Electrical Characteristics
 $V_{CC}=V_{OUT}+1V$ ($V_{OUT}\geq 1.5V$) or $V_{CC}=2.5V$ ($V_{OUT}\leq 1.5V$), $T_A=-40^{\circ}C$ to $+85^{\circ}C$.

Symbol	Parameter	Test Conditions	Min	Typ	Max	Unit
V_{IN}	Input Voltage Range		2.0		6	V
V_{OUT}	Output Voltage Range		1.2		5.0	V
I_Q	Operating Quiescent Current	$I_{OUT}=0mA$		50	120	μA
		$I_{OUT}=300mA$		90	130	
I_{SHDN}	SHDN Input Current	$\overline{SHDN}=V_{IN}$ or GND			1	μA
I_{OUT}	Output Current		300			mA
	Output Voltage Accuracy	$1mA\leq I_{OUT}\leq 300mA$, $T_A=-40^{\circ}C$ to $+85^{\circ}C$	-2.5		+2.5	%
ΔV_{DO}	Dropout Voltage	$I_{OUT}=100mA$		150	200	mV
I_{LIMIT}	Output Current Limit		330	450	700	mA
t	Startup Time Response	$R_L=68\Omega$, $C_{OUT}=1\mu F$		40		μs
V_{IL}	SHDN Input Low Voltage				0.4	V
V_{IH}	SHDN Input High Voltage		$0.6V_{CC}$			V
	Output Voltage TC			100		ppm/ $^{\circ}C$
T_{SHDN}	Thermal-Shutdown Temperature			160		$^{\circ}C$
ΔT_{SHDN}	Thermal-Shutdown Hysteresis			35		$^{\circ}C$
	Line Regulation ($V_{OUT}>4.0V$)	$V_{OUT}+0.3V\leq V_{IN}\leq 6.0V$ or $V_{IN}>2.5V$ $I_{OUT}=10mA$			0.5	%/ V
	Line Regulation ($V_{OUT}\leq 4.0V$)				0.3	
	Load Regulation ($V_{OUT}>4.0V$)	$V_{IN}=V_{OUT}+1V$ or $V_{IN}>2.5V$ $1mA\leq I_{OUT}\leq 300mA$			1.2	%
	Load Regulation ($V_{OUT}\leq 4.0V$)				0.6	
	Output Voltage Noise	10Hz to 100kHz $C_{IN}=1\mu F$, $I_{OUT}=10mA$	UM37512		170	μV_{RMS}
			UM37533		250	
			UM37550		295	
PSRR	Power Supply Ripple Rejection ($V_{OUT}>4.0V$)	$V_{IN}=V_{OUT}+1V$ or $V_{IN}>2.5V$ $I_{OUT}=100mA$	$f=100Hz$	40		dB
			$f=10kHz$	30		
	Power Supply Ripple Rejection ($V_{OUT}\leq 4.0V$)		$f=100Hz$	60		
			$f=10kHz$	30		
	ESD Rating	Human Body Mode	2			kV

Typical Performance Characteristics

Quiescent Current vs. Input Voltage

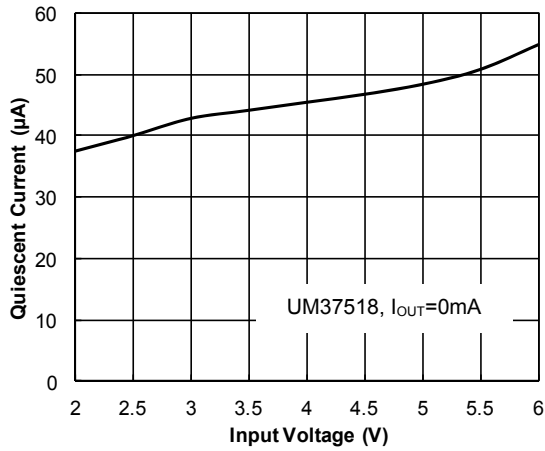

Output Voltage vs. Input Voltage

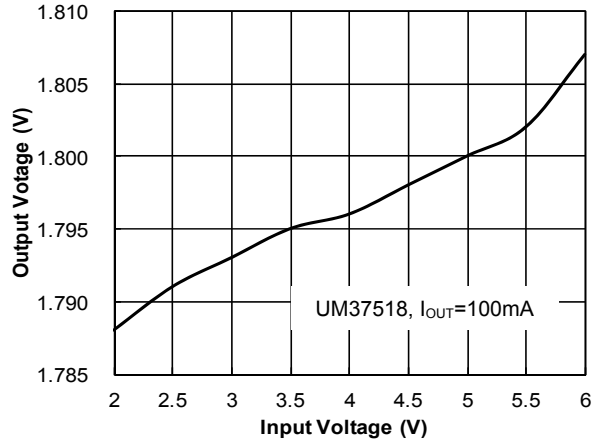

Output Voltage vs. Output Current

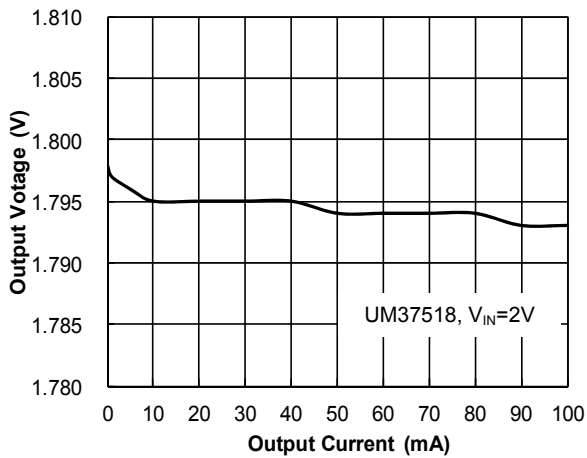

Output Voltage vs. Input Voltage

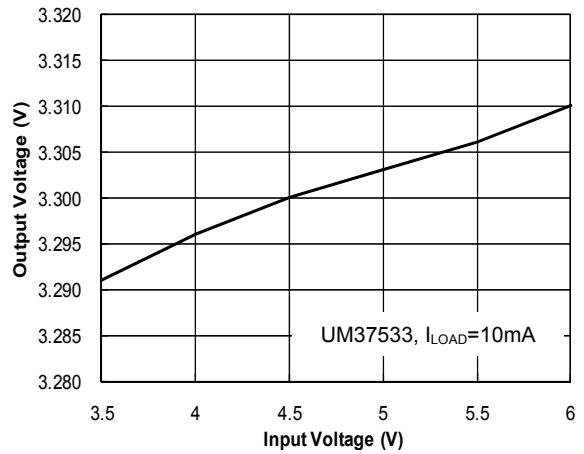

Output Voltage vs. Output Current

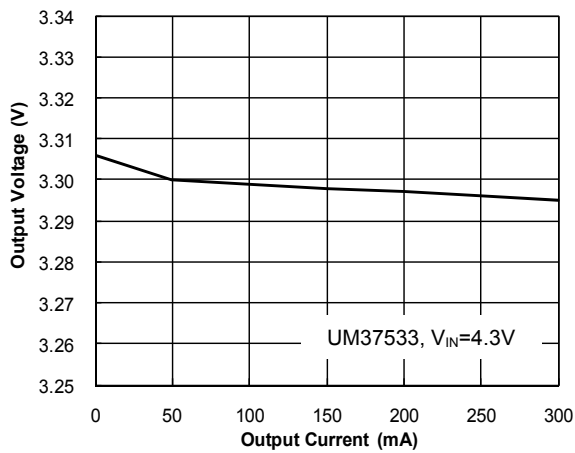

Dropout Voltage vs. Output Current

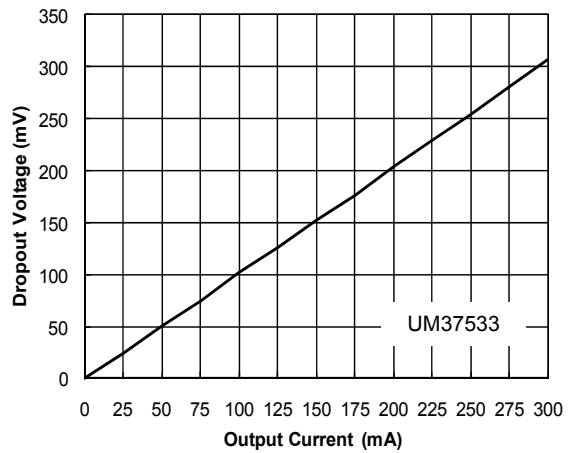

Typical Performance Characteristics (Continued)

Output Voltage vs. Temperature

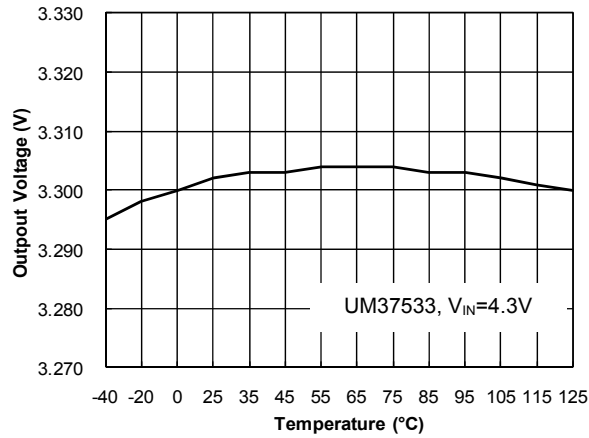

PSRR vs. Frequency

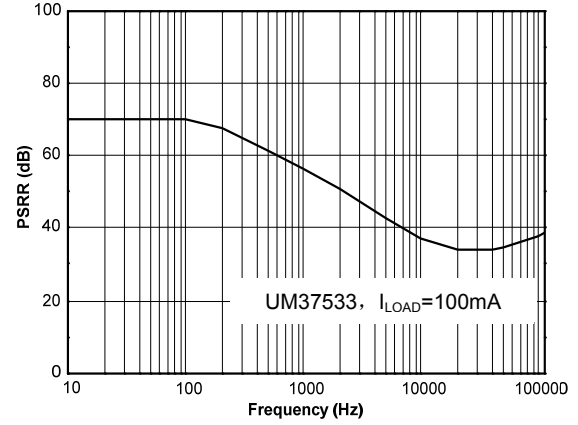

Line Transient Response

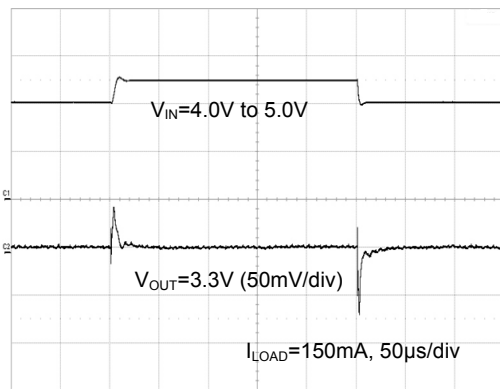

Load Transient Response

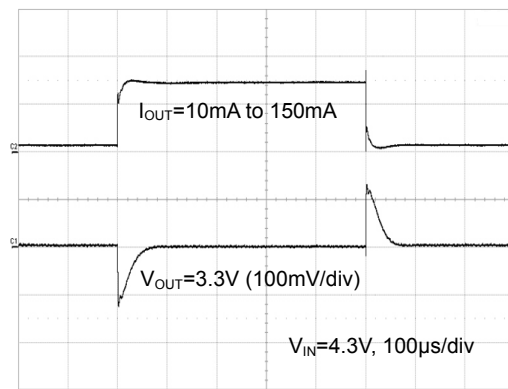

Pin Function

IN (Pin 1): Power for UM375xx and Load Power is supplied to the devices through the IN pin. The IN pin should be locally bypassed to ground if the UM375xx series are more than a few inches away from another source of bulk capacitance. In general, the output impedance of a battery rises with frequency, so it is usually advisable to include an input bypass capacitor in battery-powered circuits. A capacitor in the range of 0.1 μ F to 1 μ F is usually sufficient.

GND (Pin 2): Ground and Heat Sink. Solder to a ground plane or large pad to maximize heat dissipation.

$\overline{\text{SHDN}}$ (Pin 3): Shutdown, Active Low. This pin is used to put the UM375xx into shutdown. The $\overline{\text{SHDN}}$ pin cannot be left floating and must be tied to the input pin if not used.

NC (Pin 4): Not Connected.

OUT (Pin 5): Voltage Regulated Output. The OUT pin supplies power to the load. A minimum output capacitor of 1 μ F is required to ensure stability. Larger output capacitors may be required for applications with large transient loads to limit peak voltage transients.

Typical Application Circuit

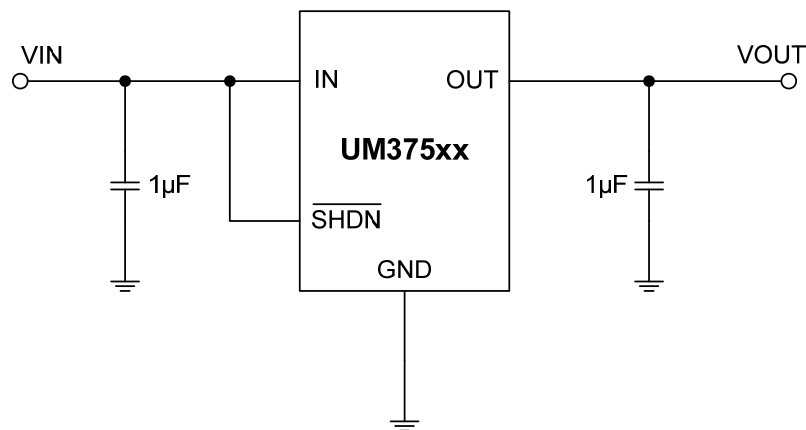

Package Information

UM375xxS: SOT23-5

Outline Drawing

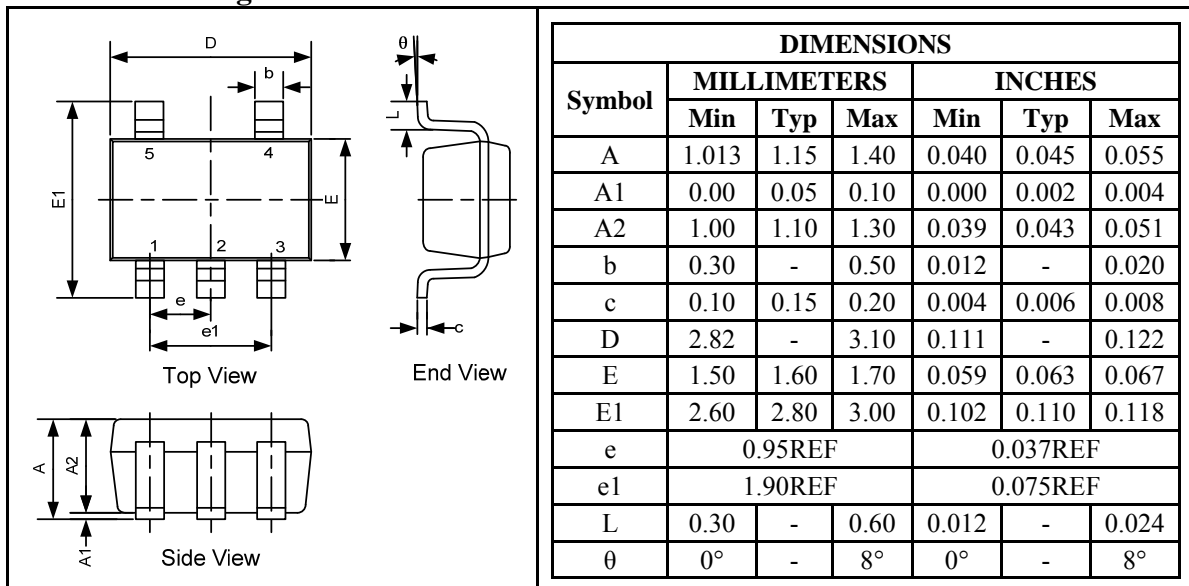

Land Pattern

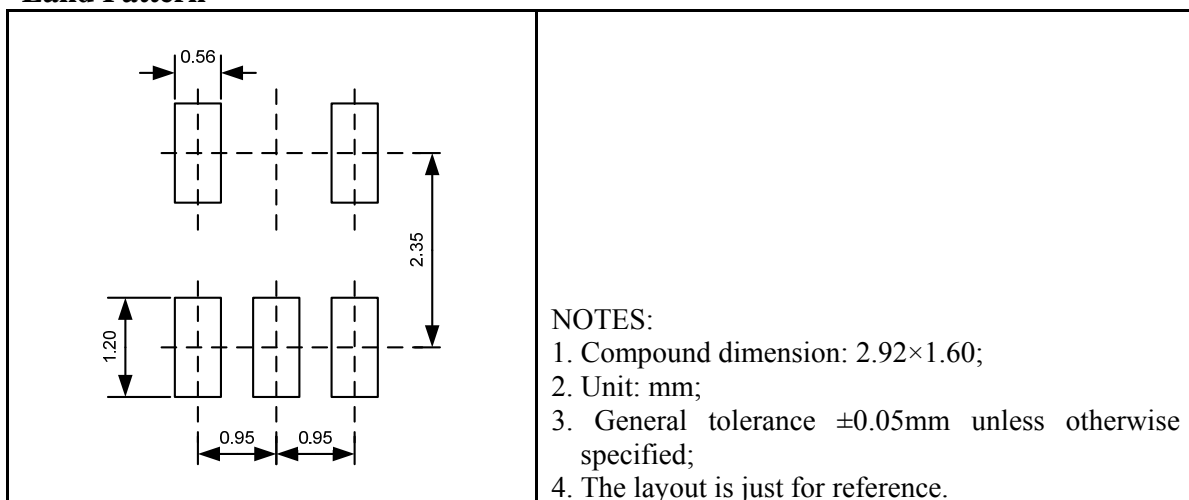

Tape and Reel Orientation



UM375xxP: SOT353

Outline Drawing

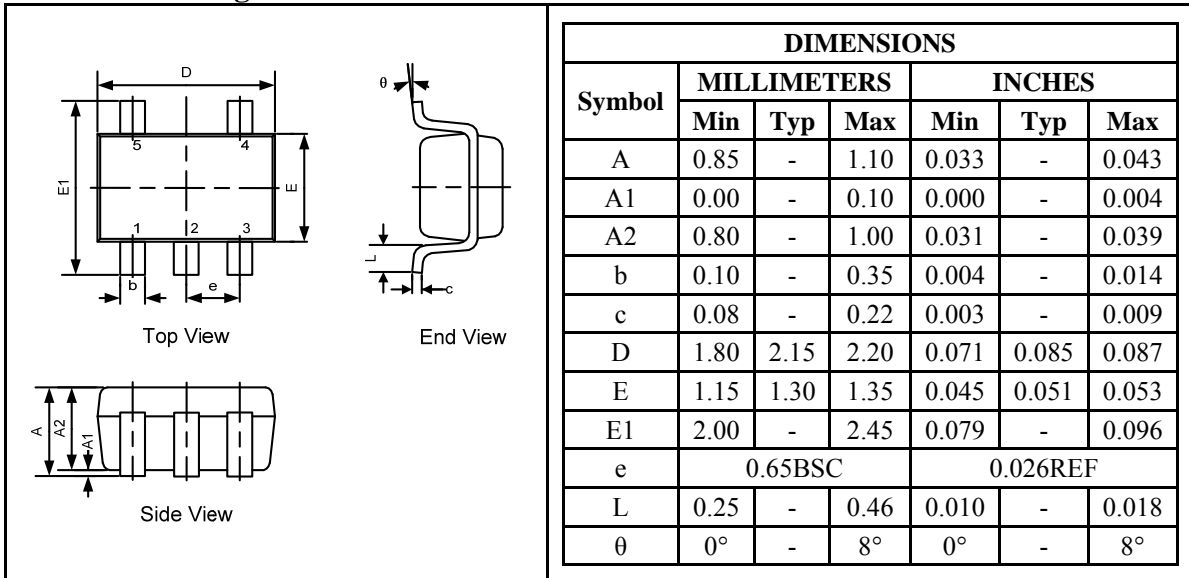

Land Pattern

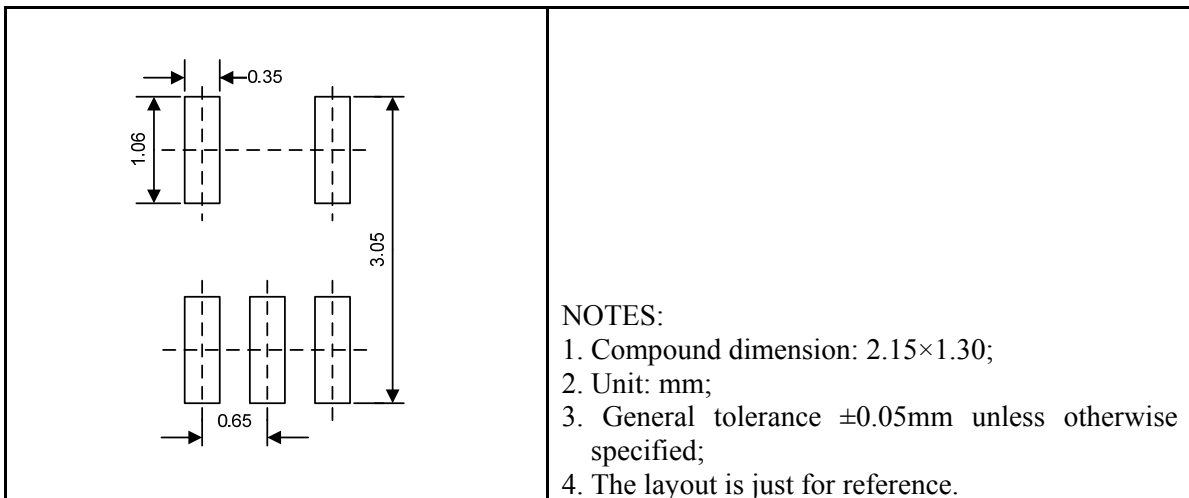

Tape and Reel Orientation

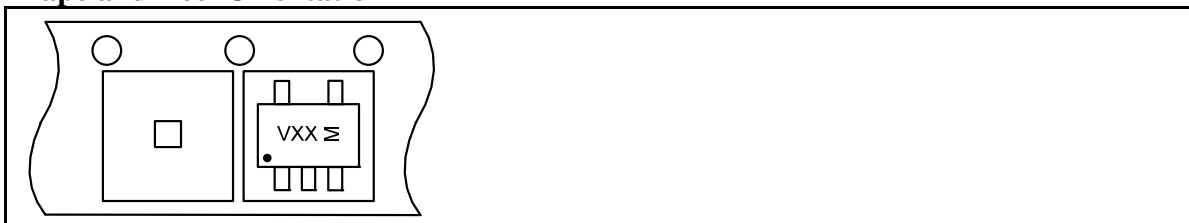

GREEN COMPLIANCE

Union Semiconductor is committed to environmental excellence in all aspects of its operations including meeting or exceeding regulatory requirements with respect to the use of hazardous substances. Numerous successful programs have been implemented to reduce the use of hazardous substances and/or emissions.

All Union components are compliant with the RoHS directive, which helps to support customers in their compliance with environmental directives. For more green compliance information, please visit:

http://www.union-ic.com/index.aspx?cat_code=RoHSDeclaration

IMPORTANT NOTICE

The information in this document has been carefully reviewed and is believed to be accurate. Nonetheless, this document is subject to change without notice. Union assumes no responsibility for any inaccuracies that may be contained in this document, and makes no commitment to update or to keep current the contained information, or to notify a person or organization of any update. Union reserves the right to make changes, at any time, in order to improve reliability, function or design and to attempt to supply the best product possible.



Union Semiconductor, Inc

Add: Unit 606, No.570 Shengxia Road, Shanghai 201210

Tel: 021-51093966

Fax: 021-51026018

Website: www.union-ic.com