



UM6845R/UM6845RA/UM6845RB

CRT Controller

Features

- Single + 5 volt ($\pm 5\%$) power supply
- Alphanumeric and limited graphics capabilities
- Fully programmable display (rows, columns, blanking, etc.)
- Interlaced or non-interlaced scan
- 50/60 Hz operation
- Fully programmable cursor
- External light pen capability
- Capable of addressing up to 16K character Video Display RAM.
- No DMA required
- Compatible with SY6845R
- Straight-binary addressing for Video Display RAM

General Description

The UM6845R is a CRT Controller intended to provide capability for interfacing any microprocessor family to CRT or TV-type raster scan displays. A unique feature

is the inclusion of several modes of operation, so that the system designer can configure the system with a wide assortment of techniques.

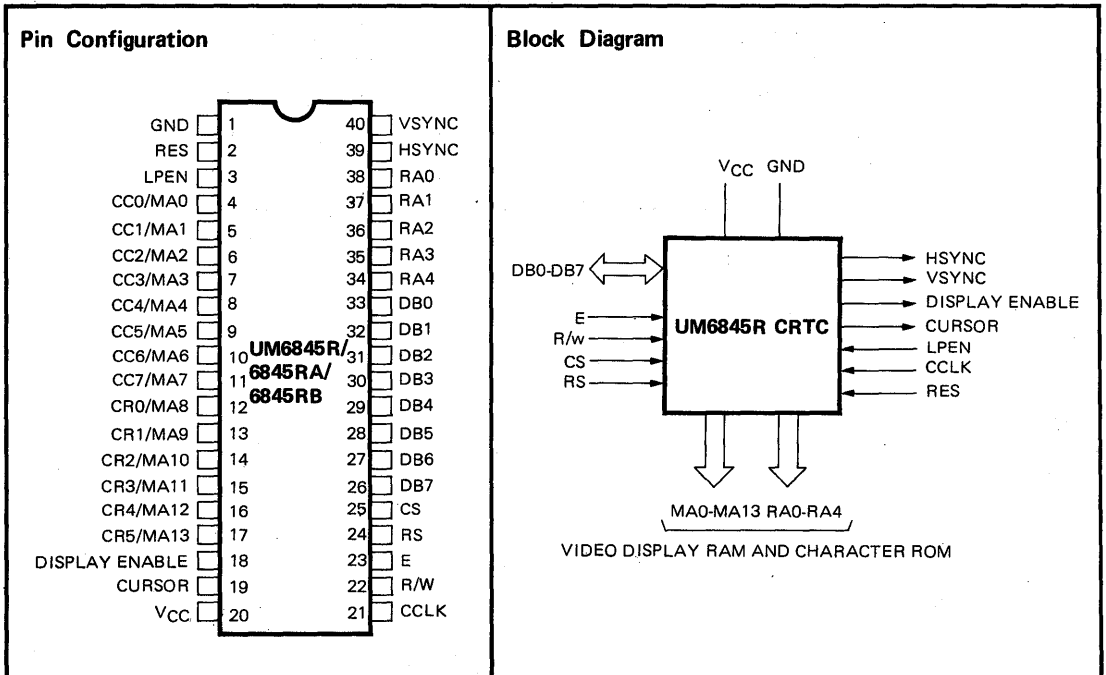

Absolute Maximum Ratings*

Supply Voltage, V_{CC} $-0.3V$ to $+7.0V$
 Input/Output Voltage, V_{IN} $-0.3V$ to $+7.0V$
 Operating Temperature, T_{OP} $0^{\circ}C$ to $70^{\circ}C$
 Storage Temperature, T_{STG} $-55^{\circ}C$ to $150^{\circ}C$

Notice:

All inputs contain protection circuitry to prevent damage due to high static discharges. Care should be exercised to prevent unnecessary application of voltages in excess of the allowable limits.

***Comments**

Stresses above those listed under "Absolute Maximum Ratings" may cause permanent damage to the device. These are stress ratings only. Functional operation of this device at these or any other conditions above those indicated in the operational sections of this specification is not implied and exposure to absolute maximum rating conditions for extended periods may affect device reliability.

D.C. Electrical Characteristics

($V_{CC} = 5.0V \pm 5\%$, $T_A = 0 - 70^{\circ}C$, unless otherwise noted)

Symbol	Characteristics	Min.	Typ.	Max.	Units
V_{IH}	Input High Voltage	2.0		V_{CC}	V
V_{IL}	Input Low Voltage	-0.3		0.8	V
I_{IN}	Input Leakage ($\phi 2, R/\overline{w}, \overline{RES}, \overline{CS}, RS, LPEN, CCLK$)	-		2.5	μA
I_{TSI}	Three-State Input Leakage (DB0-DB7) $V_{IN} = 0.4$ to $2.4V$	-10.0		+10.0	μA
V_{OH}	Output High Voltage $I_{LOAD} = -205 \mu A$ (DB0-DB7) $I_{LOAD} = -100 \mu A$ (all others)	2.4		-	V
V_{OL}	Output Low Voltage $I_{LOAD} = 1.6mA$	-		0.4	V
P_D	Power Dissipation	-	325	650	mW
C_{IN}	Input Capacitance $\phi 2, R/\overline{w}, \overline{RES}, \overline{CS}, RS, LPEN, CCLK$ DB0-DB7	-		10.0 12.5	pF pF
C_{OUT}	Output Capacitance	-		10.0	pF

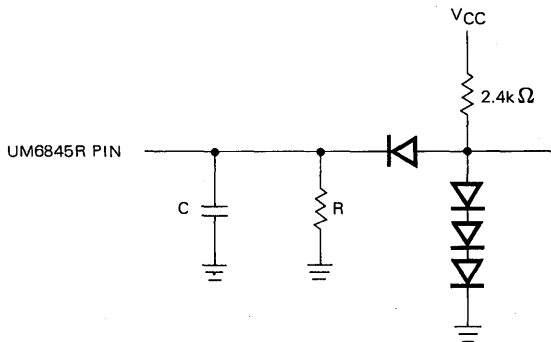
TEST LOAD

$R = 11k\Omega$ FOR DB0-DB7
 $R = 24k\Omega$ FOR ALL OTHER OUTPUTS
 $C = 130pF$ TOTAL FOR D0-D7
 $C = 30pF$ ALL OTHER OUTPUTS

CRT Controller

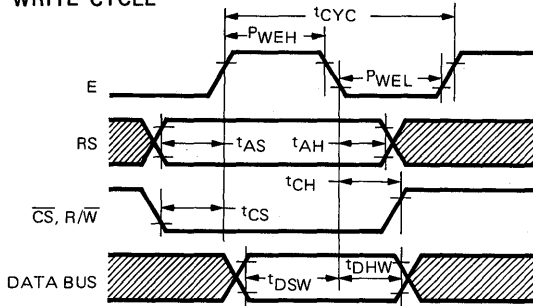
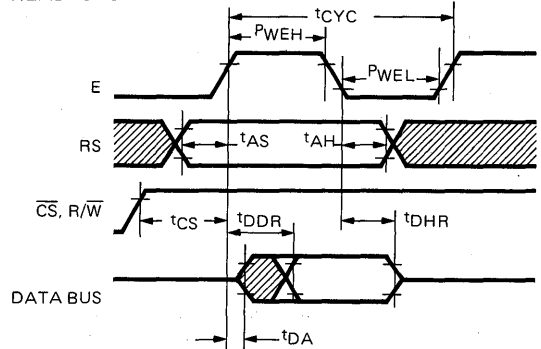
A.C. Electrical Characteristics
MPU BUS INTERFACE CHARACTERISTICS
WRITE CYCLE

READ CYCLE

WRITE TIMING CHARACTERISTICS ($V_{CC} = 5.0V \pm 5\%$, $T_A = 0 - 70^\circ C$, unless otherwise noted)

Symbol	Characteristics	UM6845R		UM6845RA		UM6845RB		Units
		Min.	Max.	Min.	Max.	Min.	Max.	
t_{CYC}	Cycle Time	1.0	—	0.5	—	0.33	—	μs
P_{WEH}	E Pulse Width, High	440	—	200	—	150	—	ns
P_{WEL}	E Pulse Width, Low	420	—	190	—	140	—	ns
t_{AS}	Address Set-Up Time	80	—	40	—	30	—	ns
t_{AH}	Address Hold Time	0	—	0	—	0	—	ns
t_{CS}	R/W, \overline{CS} Set-Up Time	80	—	40	—	30	—	ns
t_{CH}	R/W, \overline{CS} Hold Time	0	—	0	—	0	—	ns
t_{DSW}	Data Bus Set-Up Time	165	—	60	—	60	—	ns
t_{DHW}	Data Bus Hold Time	10	—	10	—	10	—	ns

 $(t_r \text{ and } t_f = 10 \text{ to } 30 \text{ ns})$
READ TIMING CHARACTERISTICS ($V_{CC} = 5.0V \pm 5\%$, $T_A = 0 - 70^\circ C$, unless otherwise noted)

Symbol	Characteristics	UM6845R		UM6845RA		UM6845RB		Units
		Min.	Max.	Min.	Max.	Min.	Max.	
t_{CYC}	Cycle Time	1.0	—	0.5	—	0.33	—	μs
P_{WEH}	E Pulse Width, High	440	—	200	—	150	—	ns
P_{WEL}	E Pulse Width, Low	420	—	190	—	140	—	ns
t_{AS}	Address Set-Up Time	80	—	40	—	30	—	ns
t_{AH}	Address Hold Time	0	—	0	—	0	—	ns
t_{CS}	R/W, \overline{CS} Set-Up Time	80	—	40	—	30	—	ns
t_{DDR}	Read Access Time (Valid Data)	—	290	—	150	—	100	ns
t_{DHR}	Read Hold Time	20	60	20	60	20	60	ns
t_{DA}	Data Bus Active Time (Invalid Data)	40	—	40	—	40	—	ns

 $(t_r \text{ and } t_f = 10 \text{ to } 30 \text{ ns})$

MEMORY AND VIDEO INTERFACE CHARACTERISTICS

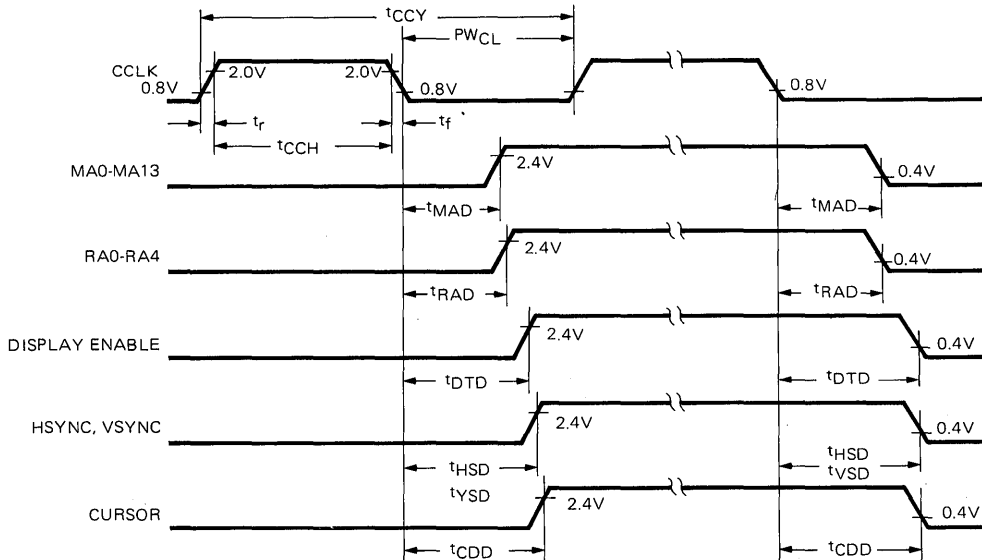
 (V_{CC} = 5.0V ± 5%, T_A = 0 to 70°C, unless otherwise noted)

Symbol	Parameter	Min.	Typ.	Max.	Units
T _{CCH}	Minimum Clock Pulse Width, High	200			ns
T _{CCY}	Clock Frequency			2.5	MHz
T _r , t _f	Rise and Fall Time for Clock Input			20	ns
t _{MAD}	Memory Address Delay Time		100	160	ns
t _{RAD}	Raster Address Delay Time		100	160	ns
t _{DTD}	Display Timing Delay Time		160	300	ns
t _{HSD}	Horizontal Sync Delay Time		160	300	ns
t _{VSD}	Vertical Sync Delay Time		160	300	ns
t _{CDD}	Cursor Display Timing Delay Time		160	300	ns

CRT Controller

LIGHT PEN STROBE TIMING

NOTE:
 "Safe" time position for LPEN positive edge to cause address n+2 to load into Light Pen Register. t_{LP2} and t_{LP1} are time positions causing uncertain results.

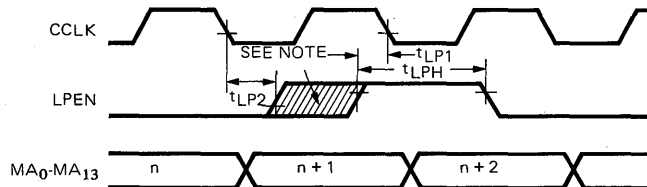

Symbol	Characteristics	UM6845R		UM6845RA		UM6845RB		Unit
		Min.	Max.	Min.	Max.	Min.	Max.	
t _{LPH}	LPEN Strobe Width	100	—	100	—	100	—	ns
t _{LP1}	LPEN to CCLK Delay	—	120	—	120	—	120	ns
t _{LP2}	CCLK to LPEN Delay	—	0	—	0	—	0	ns

 t_r and t_f = 20 ns (max.)

Pin Description

MPU INTERFACE SIGNAL DESCRIPTION

E (Enable)

The enable signal is the system input and is used to trigger all data transfers between the system microprocessor and the UM6845R. Since there is no maximum limit to the allowable E cycle time, it is not necessary for it to be a continuous clock. This capability permits the UM6845R to be easily interfaced to non-6500-compatible microprocessors.

R/W (Read/Write)

The R/W signal is generated by the microprocessor and is used to control the direction of data transfers. A high on the R/W pin allows the processor to read the data supplied by the UM6845R; a low on the R/W pin allows a write to the UM6845R.

CS (Chip Select)

The Chip Select input is normally connected to the processor address bus either directly or through a decoder. The UM6845R is selected when CS is low.

RS (Register Select)

The Register Select input is used to access internal registers. A low on this pin permits writes into the Address Register and reads from the Status Register. The contents of the Address Register is the identity of the register accessed when RS is high.

DB₀–DB₇ (Data Bus)

The DB₀–DB₇ pins are the eight data lines used for transfer of data between the processor and the UM6845R. These lines are bi-directional and are normally high-impedance except during read/write cycles when the chip is selected.

VIDEO INTERFACE SIGNAL DESCRIPTION

HSYNC (Horizontal Sync)

The HSYNC signal is an active-high output used to determine the horizontal position of displayed text. It may drive a CRT monitor directly or may be used for composite video generation. HSYNC time position and width are fully programmable.

VSYNC (Vertical Sync)

The VSYNC signal is an active-high output used to determine the vertical position of displayed text. Like HSYNC, VSYNC may be used to drive a CRT monitor or composite video generation circuits. VSYNC position and width are both fully programmable.

DISPLAY ENABLE

The DISPLAY ENABLE signal is an active-high output and is used to indicate when the UM6845R is generating active display information. The number of horizontal displayed characters and the number of vertical displayed characters are both fully programmable and together are used to generate the DISPLAY ENABLE signal.

CURSOR

The CURSOR signal is an active-high output and is used to indicate when the scan coincides with the programmed cursor position. The cursor position may be programmed to be any character in the address field. Furthermore, within the character, the cursor may be programmed to be any block of scan lines, since the start scan line and the end scan line are both programmable.

LPEN

The LPEN signal is an edge-sensitive input and is used to load the internal Light Pen Register with the contents of the Refresh Scan Counter at the time the active edge occurs. The active edge of LPEN is the low-to-high transition.

CCLK

The CCLK signal is the character timing clock input and is used as the time base for all internal count/control functions.

RES

The RES signal is an active-low input used to initialize all internal scan counter circuits. When RES is low, all internal counters are stopped and cleared, all scan and video outputs are low, and control registers are unaffected. RES must stay low for at least one CCLK period. All scan timing is initiated when RES goes high. In this way, RES can be used to synchronize display frame timing with line frequency.

MEMORY ADDRESS SIGNAL DESCRIPTION

MA0–MA13 (Video Display RAM Address Lines)

These signals are active-high outputs and are used to address the Video Display RAM for character storage and display operations. The starting scan address is fully programmable and the ending scan address is determined by the total number of characters displayed, which is also programmable, in terms of characters/line and lines/frame.

■ Binary Addressing

Characters are stored in successive memory locations. Thus, the software must be developed so that row and column co-ordinates are translated to sequentially-numbered addresses for video display memory operations.

RA0-RA4 (Raster Address Lines)

These signals are active-high outputs and are used to select each raster scan within an individual character row. The number of raster scan lines is programmable and determines the character height, including spaces between character rows.

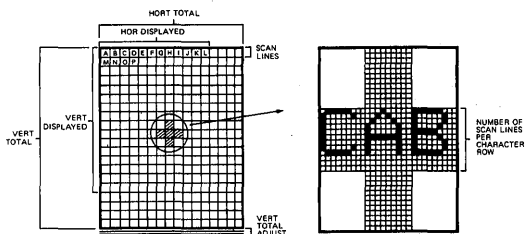

Figure 1. Video Display Format

Description of Internal Registers

Figure 1 illustrates the format of a typical video display and is necessary to understand the functions of the various UM6845R internal registers. Figure 2 illustrates vertical and horizontal timing. Figure 3 summarizes the internal registers and indicates their address selection and read/write capabilities.

Address Register

This is a 5-bit register which is used as a "pointer" to direct UM6845R data transfers to and from the system MPU. Its contents is the number of the desired register (0-31). When RS is low, then this register may be loaded; when RS is high, then the register selected is the one whose identity is stored in this register.

Status Register

This 2-bit register is used to monitor the status of the CRT, as follows:

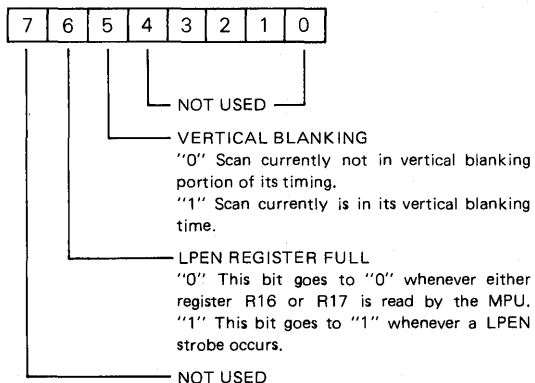
Horizontal Total (R0)

This 8-bit register contains the total of displayed and non-displayed characters, minus one, per horizontal line. The frequency of HSYNC is thus determined by this register.

Horizontal Displayed (R1)

This 8-bit register contains the number of displayed characters per horizontal line.

Horizontal Sync Position (R2)

This 8-bit register contains the position of the HSYNC on the horizontal line, in terms of the character location number on the line. The position of the HSYNC determines the left-to-right location of the displayed text on the video screen. In this way, the side margins are adjusted.

Horizontal and Vertical SYNC Widths (R3)

This 4-bit register programs the width of HSYNC.

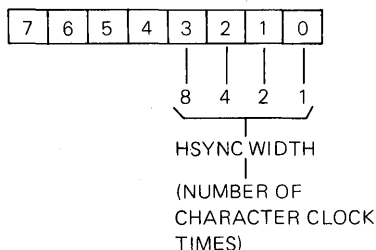

VSYNC width is set to 16 scan line times.

Vertical Total (R4)

The Vertical Total Register is a 7-bit register containing the total number of character rows in a frame, minus one. This register, along with R5, determines the overall frame rate, which should be close to the line frequency to ensure flicker-free appearance. If the frame time is adjusted to be longer than the period of the line frequency, then RES may be used to provide absolute synchronism.

Vertical Total Adjust (R5)

The Vertical Total Adjust Register is a 5-bit write only register containing the number of additional scan lines needed to complete an entire frame scan and is intended as a fine adjustment for the video frame time.

Vertical Displayed (R6)

This 7-bit register contains the number of displayed character rows in each frame. In this way, the vertical size of the displayed text is determined.

Vertical Sync Position (R7)

This 7-bit register is used to select the character row time at which the VSYNC pulse is desired to occur and, thus, is used to position the displayed text in the vertical direction.

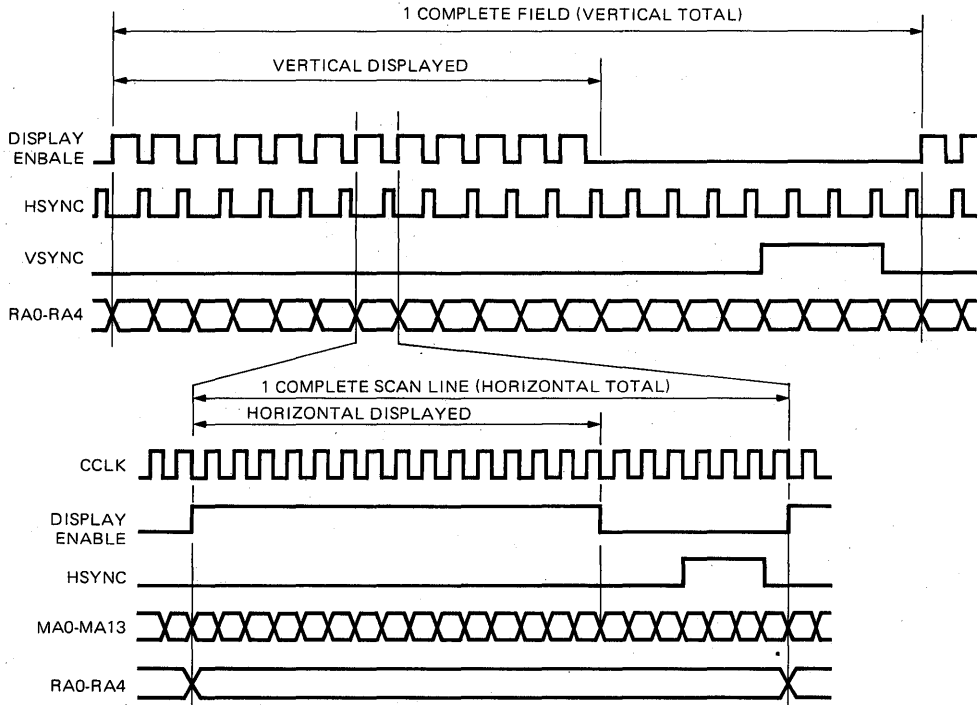
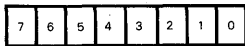

Figure 2. Vertical and Horizontal Timing

Mode Control (R8)

This register is used to select the operating modes of the UM6845R and is outlined as-follows:



BIT		OPERATION
1	0	
X	0	
0	1	Interlace SYNC Raster Scan
1	1	Interlace SYNC and Video Raster Scan

Scan Line (R9)

This 5-bit register contains the number of scan lines per character row, including spacing minus one.

Cursor Start (R10) and Cursor End (R11)

These 5-bit registers select the starting and ending scan lines for the cursor. In addition, bits 5 and 6 of R10 are used to select the cursor mode, as follows:

BIT		CURSOR MODE
6	5	
0	0	No Blinking
0	1	No Cursor
1	0	Blink at 16 x field period
1	1	Blink at 32 x field period

TOTAL = 90												
DISPLAY = 80												
TOTAL = 34 DISPLAY = 24	0	1	2	77	78	79	80	81	...	89
	80	81	82	157	158	159	160	161	...	169
	160	161	162	237	238	239	240	241	...	249

	1760	1761	1762	1837	1838	1839	1840	1841	...	1849
	1840	1841	1842	1917	1918	1919	1920	1921	...	1929
	1920	1921	1922	1997	1998	1999	2000	2001	...	2009
	2000	2001	2002	2077	2078	2079	2080	2081	...	2089

	2640	2641	2642	2717	2718	2719	2720	2721	...	2729

STRAIGHT BINARY ADDRESSING SEQUENCE

Figure 4. Display Address Sequences (with Start Address = 0) for 80 x 24 Example

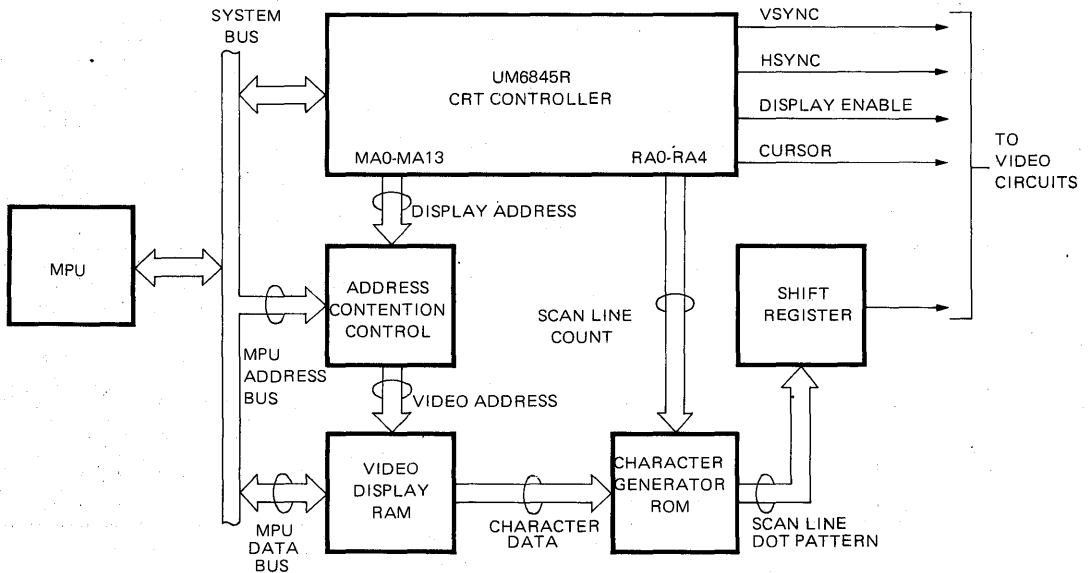

Figure 5. Shared Memory System Configuration

Memory Contention Schemes for Shared Memory Addressing

From the diagram of Figure 5, it is clear that both the UM6845R and the system MPU must be capable of addressing the video display memory. The UM6845R repetitively fetches character information to generate the video signals in order to keep the screen display active. The MPU occasionally accesses the memory to change the displayed information or to read out current data characters. Three ways of resolving this dual-contention requirement are apparent:

MPU PRIORITY

In this technique, the address lines to the video display memory are normally driven by the UM6845R unless the MPU needs access, in which case the MPU addresses immediately override those from the UM6845R and the MPU has immediate access.

$\phi 1/\phi 2$ MEMORY INTERLEAVING

This method permits both the UM6845R and the MPU access to the video display memory by time-sharing via the system $\phi 1$ and $\phi 2$ clocks. During the $\phi 1$ portion of each cycle (the time when E is low), the UM6845R address outputs are gated to the video display memory. In the $\phi 2$ time, the MPU address lines are switched in. In this way, both the UM6845R and the MPU have unimpeded access to the memory. Figure 6 illustrates the timings.

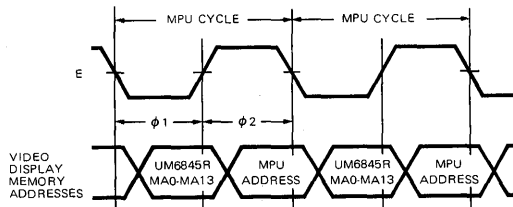

Figure 6. $\phi 1/\phi 2$ Interleaving

INTERLACE MODES

There are three raster-scan display modes (see Figure 7).

a) Non-Interlaced Mode. In this mode each scan line is refreshed at the vertical field rate (50 or 60Hz).

In the interlaced scan modes, even and odd fields alternate to generate frames. The horizontal and vertical timing relationship causes the scan lines in the odd fields to be displaced from those in the even fields. The two additional raster-scan display modes pertain to interlaced scans.

b) Interlace Sync Mode. This mode is used when the same information is to be displayed in both odd and even fields. Enhanced readability results because the spaces between adjacent rows are filled and a higher quality character is displayed. This is achieved with only a slight alteration in the device operation: in alternate fields, the position of the VSYNC signal is delayed by $\frac{1}{2}$ of a scan line time. This is illustrated in Figure 8 and is the only difference in the UM6845R operation in this mode.

c) Interlaced Sync and Video Mode. This mode is used to double the character density, on the screen by displaying the even lines in even fields and the odd lines in odd fields. As in the Interlace-Sync mode, the VSYNC position is delayed in alternate display fields. In addition, the address generation is altered.

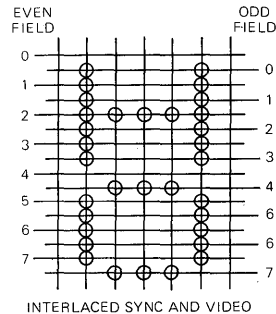
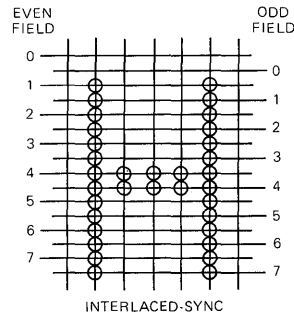
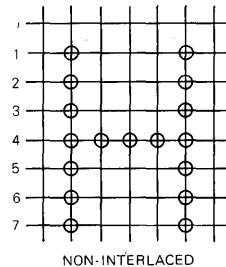

Figure 7. Comparison of Display Modes

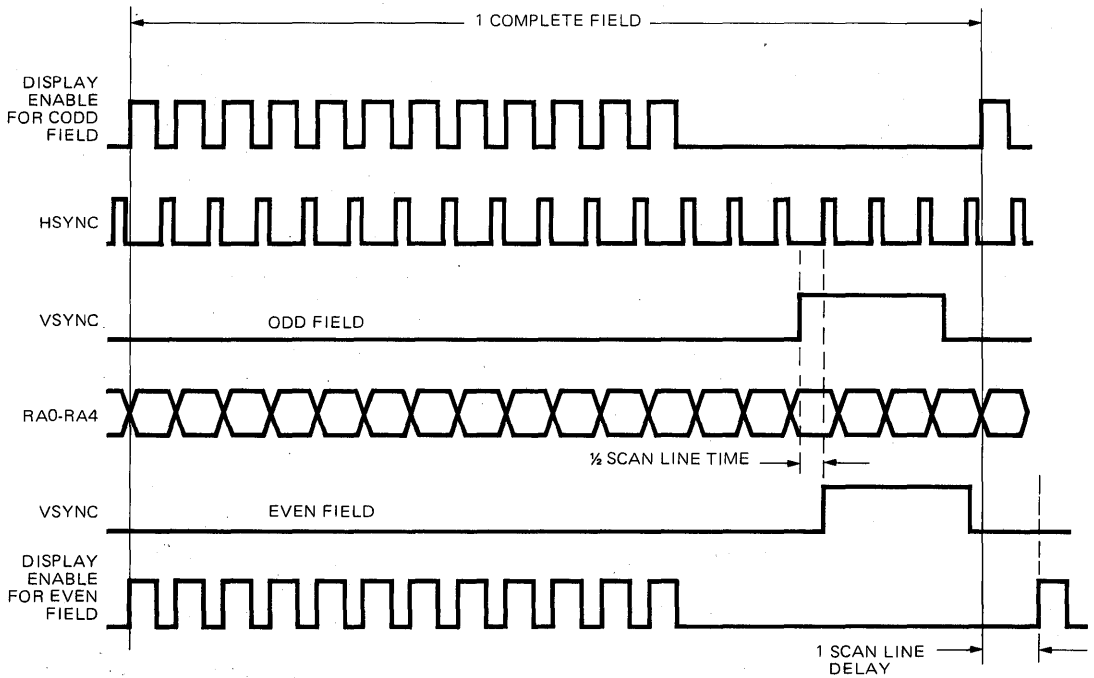

Figure 8. Interface Sync Mode and Interface Sync & Video Mode Timing

CRTC Register Comparison Table

NON-INTERLACE

Register	UM6845R MC6845 MC6845*1	MC6845R HD6845R	UM6845 HD6845S	UM6845E	SYS6545-1
R0 Htotal	Total-1	Total-1	Total-1	Total-1	Total-1
R1 Hdisp	Actual	Actual	Actual	Actual	Actual
R2 Hsync	Actual	Actual	Actual	Actual	Actual
R3 Sync Width	Horizontal (& Vertical *1)	Horizontal	Horizontal & Vertical	Horizontal & Vertical	Horizontal & Vertical
R4 Vtotal	Total-1	Total-1	Total-1	Total-1	Total-1
R5 Vtotal Adjustment	Any Value	Any Value	Any Value	Any Value	Any Value Except R5
R6 Vdisp	Any Value <R4	Any Value <R4	Any Value <R4	Any Value <R4	Any Value <R4
R7 Vsync	Actual-1	Actual-1	Actual-1	Actual-1	Actual-1
R8 B0-1	Interlace	Interlace	Interlace	Interlace	Interlace
Mode Select B2	—	—	—	Row/Column or Binary Addr.	Row/Column or Binary Addr.
B3	—	—	—	Shared or Transparent Addr.	Shared or Transparent Addr.
B4	(Display Enable Skew *1)	—	Display Enable Skew	Display Enable Skew	Display Enable Skew
B5	(Display Enable Skew *1)	—	Display Enable Skew	Cursor Skew	Cursor Skew
B6	(Cursor Skew *1)	—	Cursor Skew	RA4/ Transparent	RA4/ Transparent
B7	(Cursor Skew *1)	—	Cursor Skew	Transparent	Transparent
R9 Scan Lines	Total-1	Total-1	Total-1	Total-1	Total-1
R10 Cursor Start	Actual	Actual	Actual	Actual	Actual
R11 Cursor End	Actual	Actual	Actual	Actual	Actual
R12/R13 Display Addr.	Write Only Read/Write (MC6845 & *1)	Read/Write	Read/Write	Write Only	Write Only
R14/R15 Cursor Position	Read/Write	Read/Write	Read/Write	Read/Write	Read/Write
R16/R17 Position	Read Only	Read Only	Read Only	Read Only	Read Only
R18/R19 Update Addr. Register	N/A	N/A	N/A	Transparent Mode Only	Transparent Mode Only
R31 Dummy Register	N/A	N/A	N/A	Transparent Mode Only	Transparent Mode Only
Status Register	Yes (UM6845R)	No	No	Yes	Yes

CRTC Register Comparison Table (Continued)
INTERLACE SYNC

Register	UM6845R MC6845 MC6845*1	MC6845R HD6845R	UM6845 HD6845S	UM6845E	SYS6545-1
R0 Htotal	Total-1 = Odd or Even	Total-1 = Odd	Total-1 = Odd	Total-1 = Odd or Even	Total-1 = Odd

INTERLACE SYNC AND VIDEO

R4 Vtotal	Total-1	Total-1	Total-1	Total-1	Total/2-1
R6 Vdisp	Total	Total/2	Total	Total	Total/2
R7 Vsync	Actual-1	Actual-1	Actual-1	Actual-1	Actual/2
R9 Scan Lines	Total-1 Odd/Even	Total-1 Only Even	Total-1 Odd/Even	Total-1 Odd/Even	Total-1 Odd/Even
R10 Cursor Start	Odd/Even	Both Odd or	Odd/Even	Odd/Even	Odd/Even
R11 Cursor End	Odd/Even	Both Even	Odd/Even	Odd/Even	Odd/Even
lcCLK	2.5 MHz	2.5 MHz	3.7 MHz	3.7 MHz	2.5 MHz

Ordering Information

Part Number	CPU Clock Rate	Package
UM6845R	1 MHz	Plastic
UM6845RA	2 MHz	Plastic
UM6845RB	3 MHz	Plastic