

SOD-323 Single Line TVS Diode for ESD Protection**Description**

TVS diodes are designed to replace multilayer varistors (MLVs) in portable applications such as cell phones, notebook computers, and PDA's. They offer superior electrical characteristics such as lower clamping voltage and no device degradation when compared to MLVs.

The UMD05-323 is a Uni-Directional TVS that is designed to provide high overvoltage protection by clamping action and have instantaneous response to transient overvoltages. The SOD-323 is a very small package which allows space saving on high density printed circuit board and also gives the designer the flexibility to protect one line in applications where arrays are not practical.

Features

- * Solid-state silicon-avalanche technology
- * SOD-323 package
- * Uni-Directional protection
- * Protects one I/O or Power line
- * 500 Watts peak pulse power ($t_p = 8/20\mu s$)
- * Working voltage: 5V
- * Low clamping factor V_{cl}/V_{br}
- * Low leakage current
- * Complies with the following standards:
 - IEC 61000-4-2 (ESD) Air-15kv, Contact-8kv
 - IEC 61000-4-4 (EFT) 40A (5/50ns)
 - IEC 61000-4-5 (Surge) 24A (8/20 μs)

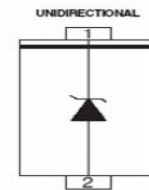
High-Power Surge TVS**SOD-323 Pin Configuration**

<u>Pin</u>	<u>Description</u>
1	*****Cathode
2	*****Anode

Mechanical Characteristics

- * Molded JEDEC SOD-323 package
- * Weight 5 milligrams (Approximate)
- * Available in Lead-Free Pure-Tin Plating
- * Solder Reflow Temp.: Pure-Tin (Sn), 260-270°C
- * Consult Factory for Leaded Device Availability
- * Flammability Rating UL 94V-0
- * 8mm Tape and Reel per EIA Standard 481
- * Device Marking: Marking Code, Polarity Band

Applications

- * Cellular Handset
- * PDA
- * Notebook
- * Digital Camera
- * Wifi Phone

SOD-323 Single Line TVS Diode for ESD Protection

Absolute Maximum Ratings @ 25°C unless otherwise specified			
Parameter	Symbol	Value	Units
Peak Pulse Power; pulse waveform = 8/20µs	P _{pp}	500	W
Peak Pulse Current; pulse waveform = 8/20µs	I _{pp}	42	A
ESD per IEC 61000-4-2 (Air)	V _{pp}	±20	kV
ESD per IEC 61000-4-2 (Contact)		±15	
Operating Temperature	T _j	-55 to 150	°C
Storage Temperature	T _{stg}	-55 to 150	°C

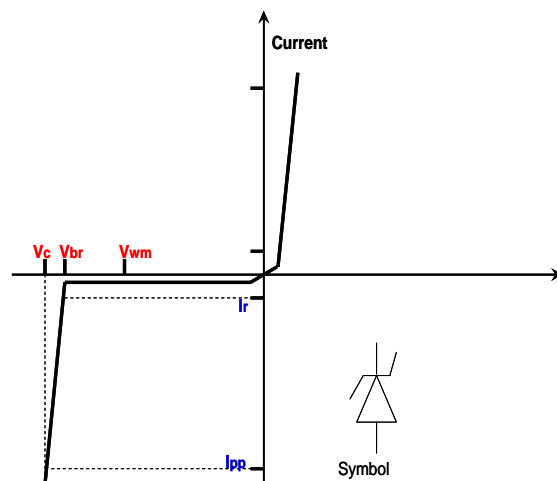
Uni-Directional Protection

Electrical Characteristics @ 25°C unless otherwise specified						
Parameter	Symbol	Conditions	Minimum	Typical	Maximum	Units
Stand-off Voltage	V _{wm}				5.0	V
Breakdown Voltage	V _{br}	I _t =1mA	6.0			V
Leakage Current	I _r	V _{wm} =5V, T=25°C			10	µA
Clamping Voltage	V _c	I _{pp} =1A, T _p =8/20µs			9.8	V
Clamping Voltage	V _c	I _{pp} =42A, T _p =8/20µs			13.5	V
Peak Pulse Current	I _{pp}	T _p =8/20µs			42	A
Junction Capacitance	C _j	V _r =0V, f=1MHz		350		pF

SOD-323 Single Line TVS Diode for ESD Protection

Electrical Characteristics Graphs

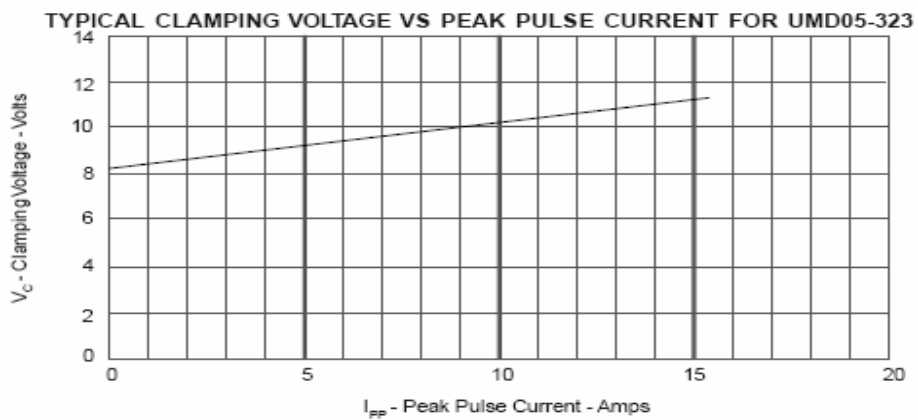
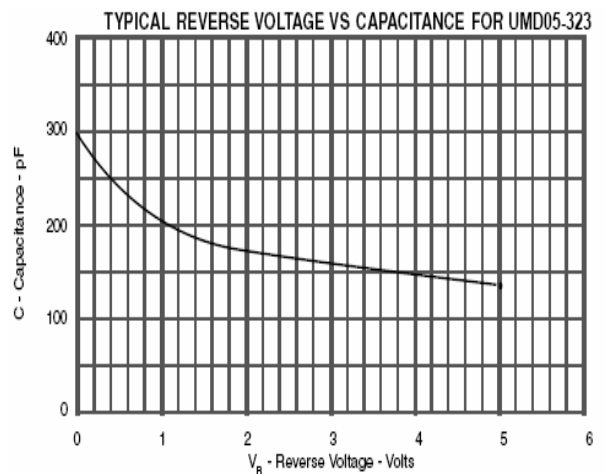
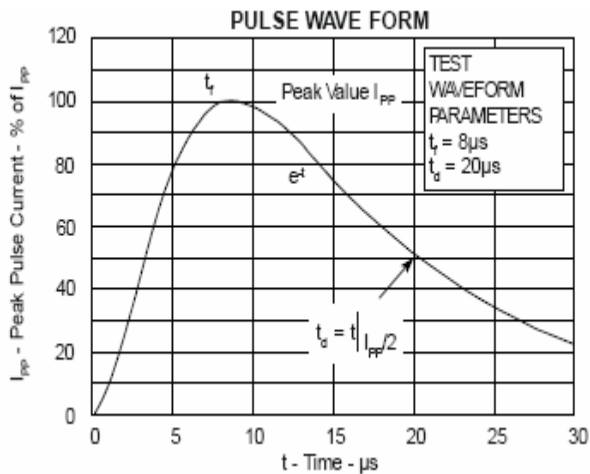
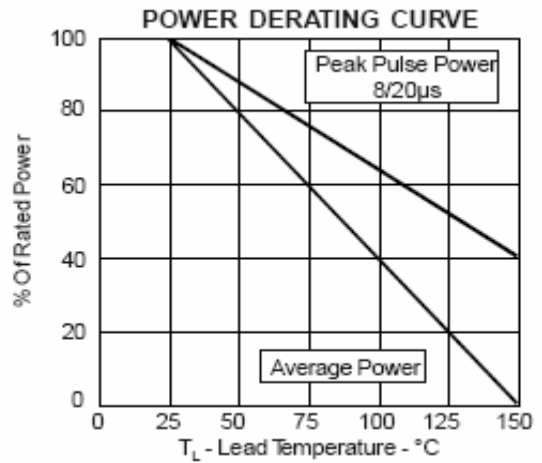
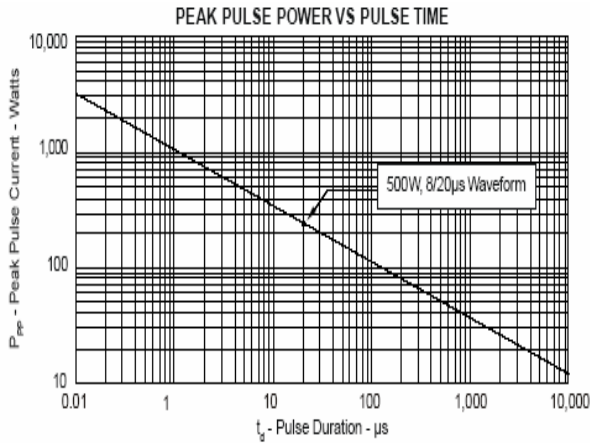

SOD-323 Single Line TVS Diode for ESD Protection

Applications Information

The UMD05-323 is designed to protect one data, I/O, or power supply line. The Device is Uni-Directional and may be used on lines where the signal polarity is above ground. The cathode band should be placed towards the line that is to be protected.

When a transient voltage appears, the UMD05-323 becomes active, clamping the voltage to a certain level and directing the transient current to ground.

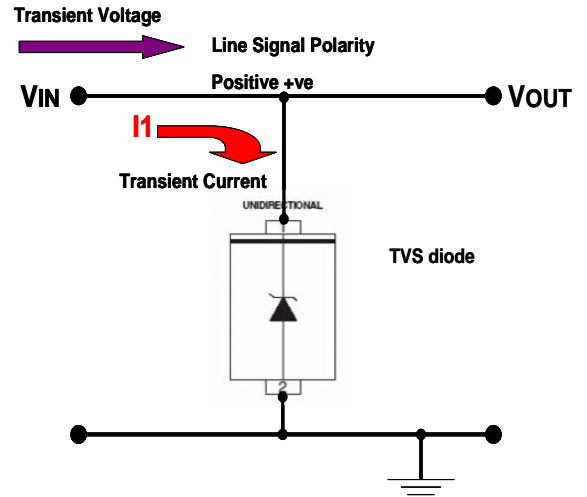

Mobile Handset

Main Parts in Mobile Phone

- Baseband
 - ❖ Central Processing Unit (CPU)
 - ❖ Power Management Unit (PMU)
 - ❖ Flash IC
- RF Module
 - ❖ RF Transceiver
 - ❖ RF Power Amplifier
- LCD & Backlight

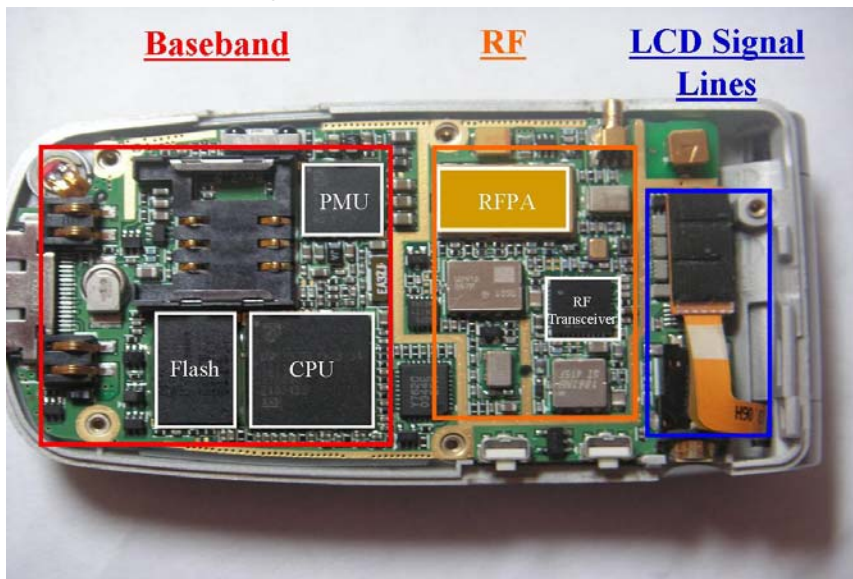

SOD-323 Single Line TVS Diode for ESD Protection

Areas That Require ESD Protection

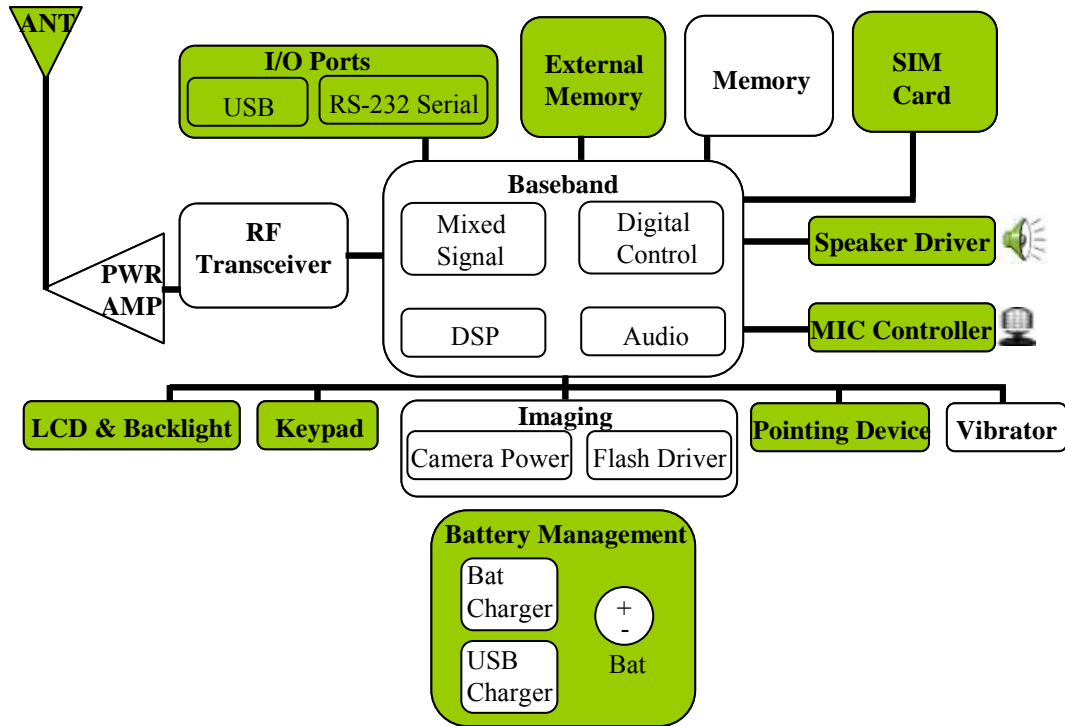

UMD05-323 on Battery Management Application

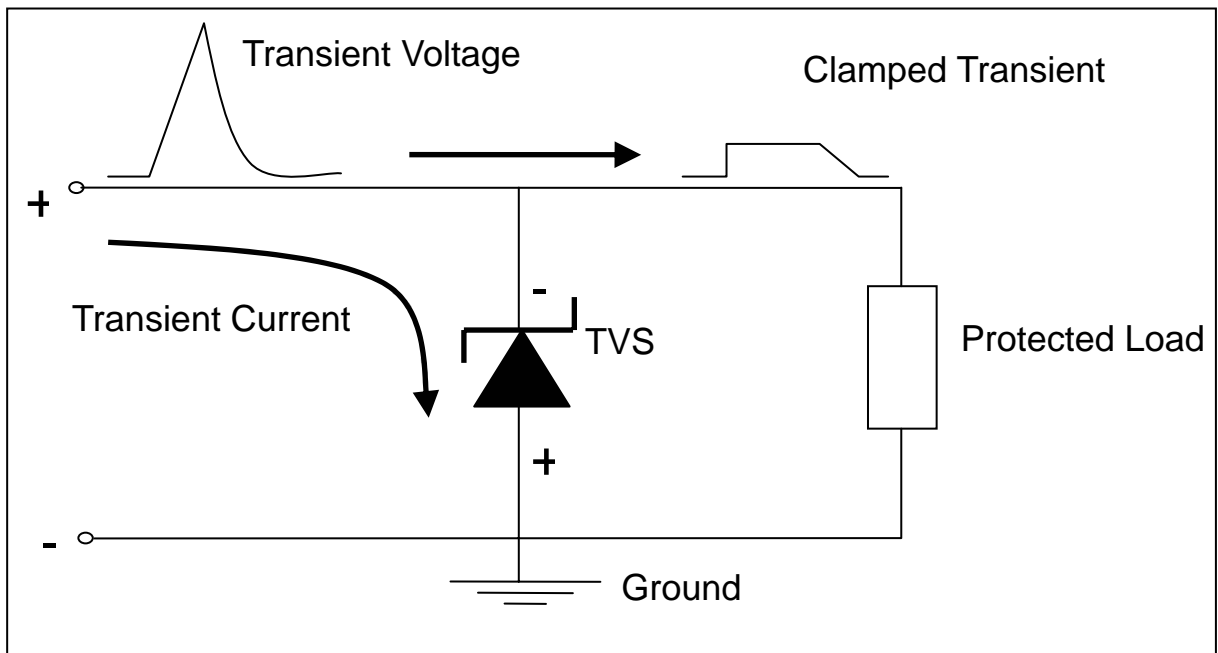

SOD-323 Single Line TVS Diode for ESD Protection

Circuit Board Layout Recommendations

Good circuit board layout is critical for the suppression of fast rise-time transients such as ESD. The following guidelines are recommended:

- Place the TVS near the input terminals or connectors to restrict transient coupling.
- Minimize the path length between the TVS and the protected line.
- The ESD transient return path to ground should be kept as short as possible.
- Place a TVS and decoupling capacitor between power and ground of components that may be vulnerable to electrostatic discharges to the ground plane.
- Minimize all conductive loops including power and ground loops.
- Use multilayer boards when possible.
- Minimize interconnecting line lengths.
- Never run critical signals near board edges.
- Fill unused portions of the PCB with ground plane.

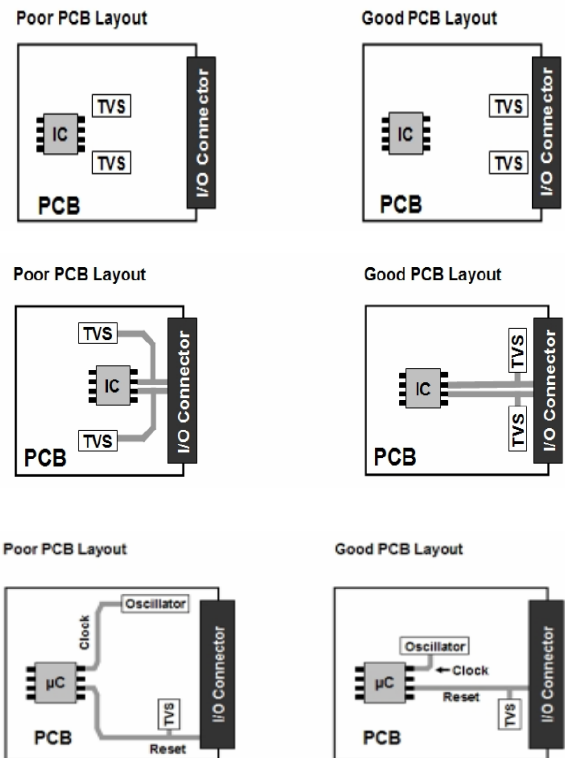

Matte Tin Lead Finish

Matte tin has become the industry standard lead-free replacement for SnPb lead finishes. A matte tin finish is composed of 100% tin solder with large grains. Since the solder volume on the leads is small compared to the solder paste volume that is placed on the land pattern of the PCB, the reflow profile will be determined by the requirements of the solder paste. Therefore, these devices are compatible with both lead-free and SnPb assembly techniques. Unlike other lead-free compositions, matte tin does not have any added alloys that can cause degradation to solder joint.

Component Placement

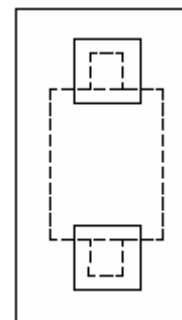

SOD-323 on recommended (SOD-323) Solder Pad.

SOD-323 Single Line TVS Diode for ESD Protection
Soldering Method for UMD's Products

1. Storage environment: Temperature = 10°C~35°C Humidity = 65%±15%
2. Reflow soldering of surface-mount devices

Temperature profile

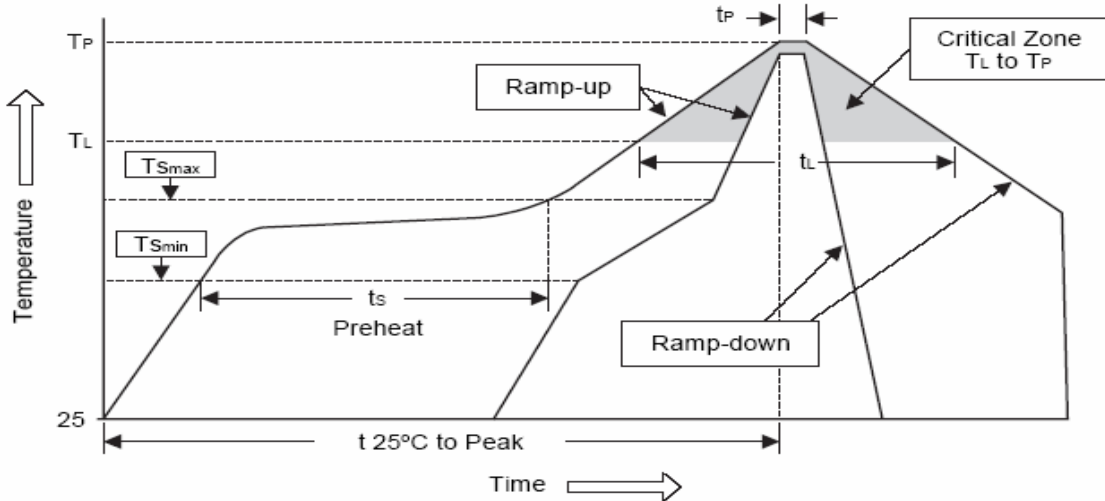

Profile Feature	Pb-Free Assembly
Average ramp-up rate (T _L to T _P)	<3°C/sec
Preheat <ul style="list-style-type: none"> - Temperature Min (T_{Smin}) - Temperature Max (T_{Smax}) - Time (min to max) (t_s) 	150°C 200°C 60~180sec
T _{Smax} to T _L <ul style="list-style-type: none"> - Ramp-up Rate 	<3°C/sec
Time maintained above: <ul style="list-style-type: none"> - Temperature (T_L) - Time (t_L) 	220°C 50~145sec
Peak Temperature (T _P)	260°C +0/-5°C
Time within 5°C of actual Peak Temperature (t _P)	20~40sec
Ramp-down Rate	<6°C/sec
Time 25°C to peak Temperature	<8 minutes

Flow (wave) soldering (solder dipping)

Products	Dipping time
Pb devices	5sec±1sec
Pb-Free devices	5sec±1sec

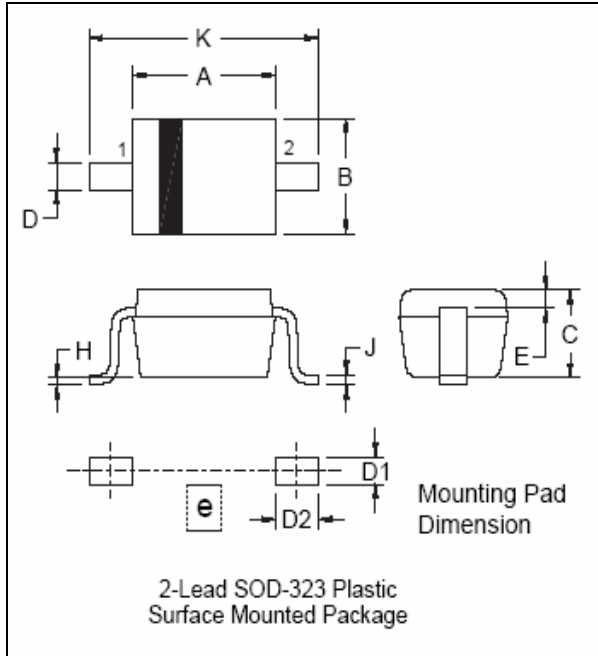
SOD-323 Single Line TVS Diode for ESD Protection
SOD-323 Dimension Drawing

*: Typical

Dim	Dimensions			
	Inches		mm	
	Min	Max	Min	Max
A	0.063	0.071	1.60	1.80
B	0.045	0.057	1.15	1.45
C	0.031	0.039	0.80	1.00
D	0.010	0.016	0.25	0.40
D1	-	*0.016	-	*0.4
D2	-	*0.020	-	*0.5
E	0.006	-	0.15	-
e	-	*0.087	-	*2.20
H	-	0.004	-	0.10
J	0.004	0.007	0.089	0.18
K	0.091	0.106	2.30	2.70

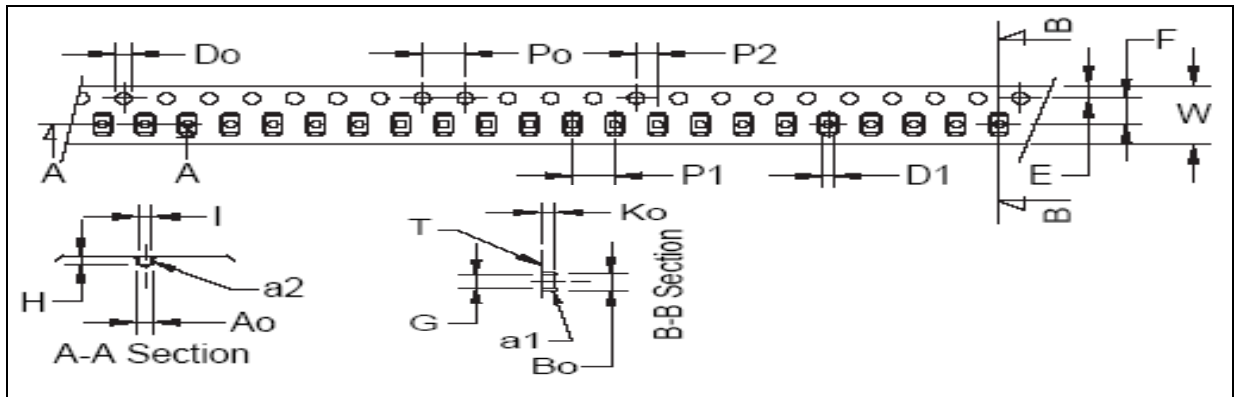
SOD-323 Carrier Dimension

Dim	Min Inch	Max Inch	Min mm	Max mm	Dim	Min Inch	Max Inch	Min mm	Max mm
A0	0.056	0.064	1.42	1.62	D0	0.055	0.063	1.40	1.60
B0	0.110	0.118	2.80	3.00	D1	0.030	0.049	0.75	1.25
K0	0.049	0.057	1.25	1.45	W	0.311	0.327	7.90	8.30
P0	0.154	0.161	3.90	4.10	G	-	*0.082	-	*2.08
P1	0.154	0.161	3.90	4.10	H	-	*0.042	-	*1.07
P2	0.077	0.081	1.95	2.05	I	-	*0.033	-	*0.84
T	0.009	0.011	0.24	0.27	a1	-	5°	-	5°
E	0.065	0.073	1.65	1.85	a2	-	8°	-	8°
F	0.136	0.140	3.45	3.55	*: Typical				

SOD-323 Single Line TVS Diode for ESD Protection**Marking Code**

Part Number	Device Marking
UMD05-323	05

Ordering Information

Part Number	Lead Finish	Qty Per Reel	Reel Size
UMD05-323	Pb-Free	3,000	7 inch

Please Read Carefully

Information in this document is provided solely in connection with UMD products. UMD reserves the right to make changes, corrections, modifications or improvements, to this document, and the products and services described herein at any time, without notice.

All UMD products are sold pursuant to UMD's terms and conditions of sale.

Purchasers are solely responsible for the choice, selection and use of the UMD products and services described herein, and UMD assumes no liability whatsoever relating to the choice, selection or use of the UMD products and services described herein.

No license, express or implied, by estoppels or otherwise, to any intellectual property rights is granted under this document. If any part of this document refers to any third party products or services it shall not be deemed a license grant by UMD for the use of such third party products or services, or any intellectual property contained therein or considered as a warranty covering the use in any manner whatsoever of such third party products or services or any intellectual property contained therein.

Unless otherwise set forth in UMD's Terms and Conditions of sale UMD disclaims any express or implied warranty with respect to the use and/or sale of UMD products including without limitation implied warranties of merchantability, fitness for a particular purpose (and their equivalents under the laws of any jurisdiction), or infringement of any patent, copyright or other intellectual property right.

Unless expressly approved in writing by an authorized UMD representative, UMD products are not recommended, authorized or warranted for use in military, air craft, space, life saving, or life sustaining applications, nor in products or systems where failure or malfunction may result in personal injury, death, or severe property or environmental damage. Resale of UMD products with provisions different from the statements and/or technical features set forth in this document shall immediately void any warranty granted by UMD for the UMD product or service described herein and shall not create or extend in any manner whatsoever, any liability of UMD.

2010 United Micro Device Inc – All rights reserved

www.umdcorp.com