

SPECIFICATION

OF

LIQUID CRYSTAL DISPLAY MODULE



CUSTOMER : URT-STD

Model No. : UMNH-8442MD-3T

Model version : 0

Document Revision : 3

CUSTOMER APPROVED SIGNATURE			

This specification need to be signed by purchaser or customer as a specification of products production and delivery from URT. Without signature of this specification , any purchase order for this model no. will be treated and considered that this specification is automatically acknowledged and accepted by purchaser or customer.

 **U.R.T.**  **UNITED RADIANT TECHNOLOGY CORPORATION**

Allen Wang
APPROVED

George Tseng
CHECKED

Angus Chiu
CHECKED

Sharon Tsai
PREPARED

Aug-16-2010
Date

COMPANY : No. 2,Fu-hsing Road,Taichung Economic Processing Zone,Tantzu,Taichung,Taiwan,R.O.C.

TEL: 886-4-25314277

FAX: 886-4-25313067



Revision 3 ; UMNH-8442MD-3T Ver. 0 ; August-16-2010

Page: 1

This document has been signed by Digital Signature Approval System



UNITED RADIANT TECHNOLOGY CORP .

Headquarter office: NO.2 FU-SHING ROAD, T.E.P.Z. TANTZU, TAICHUNG, TAIWAN, R.O.C.
TEL: +886-4-25314277 FAX: +886-4-25313067
Factory: NO.12 CHIEN KUO ROAD, T.E.P.Z., TANTZU, TAICHUNG, TAIWAN, R.O.C.

To Whom It May Concern:

In continuing to develop and promote the strategic partnership between United Radiant Technology (URT) and Microtips USA (MTUSA), URT is please to announce that we have entered into an agreement with MTUSA to support some key projects only through MTUSA and as such the attached spec with URT Part no. will be manufactured by URT but support and logistic of the sales will be handled by MTUSA.

URT is confident that this arrangement between our two companies will ultimately benefit the end customer.

Thank You.

Raymond Chen

A handwritten signature in cursive script that reads 'Raymond Chen'. The signature is written in black ink and is positioned above a horizontal line.

Sales Manager: URT

Revision record

Document Revision	Model No. Version No.	Description	Revision by
0	UMNH-8442MD-T Version No. 0	2.4" TFT	Ken Lin Jeffry Chen 25-Mar-2010
1	UMNH-8442MD-1T Version No. 0	Change the PLZ supplier.	Ken Lin Jeffry Chen 26-Apr-2010
2	UMNH-8442MD-2T Version No. 0	Change the panel number to F02419-01U.	Jenny Huang Jeffry Chen
3	UMNH-8442MD-3T Version No. 0	1. Modify the module number from UMNH-8442MD-2T to UMNH-8442MD-3T. 2. Revised the LCM Typ. Brightness to 250 cd/m ² .	Jenny Huang Jeffry Chen 16-Aug-2010
		Revision 3 ; UMNH-8442MD-3T Ver. 0 ; August-16-2010	Page: 2

CONTENTS:

No.	Item	Page
1	BASIC SPECIFICATION	
	1.1 Mechanical Specification	4
	1.2 Display Specification	4
	1.3 Outline Dimension	5
	1.4 Block Diagram	6
	1.5 Interface Pin	7
2	ELECTRICAL CHARACTERISTICS	
	2.1 Absolute Maximum Ratings	8
	2.2 DC Characteristics	9
	2.2.1 Back-light	9
	2.3 Command Sequence	10~11
2.4 AC Characteristics	12~15	
3	OPTICAL CHARACTERISTICS	
	3.1 Condition	17
	3.2 Definition of Optical Characteristics	18~19
4	RELIABILITY	20
5	PRODUCT HANDING AND APPLICATION	21
6	DATECODE	22
7	PACKING & LOTNO	23~24
8	INSPECTION STANDARD	25~28

1. BASIC SPECIFICATION

1.1 Mechanical specifications

Items	Nominal Dimension	Unit
Active screen size	2.4" diagonal	-
Dot Matrix	240 x RGB x 320	Pixel
Module Size (W x H x T)	42.7 x 60.26 x 2.75	mm.
Active Area (W x H)	36.72 x 48.96	mm.
Pixel Size (W×H)	0.153 x 0.153	mm.
Color depth	262K	color
Interface	8/9/16/18-bit MPU parallel	-
Driving IC Package	COG	-
Module weight	10	g

1.2 Display specification

Display	Descriptions	Note
LCD Type	a-Si TFT	-
LCD Mode	TN/Normal white	-
Polarizer Mode	Transmissive	-
Polarizer Surface	Normal	-
Pixel arrangement	RGB-stripe	-
Backlight Type	LED	-
Viewing Direction(Gray inversion)	12 O'clock Direction	-

* Color tone is slightly changed by temperature and driving voltage.

1.3 Outline dimension

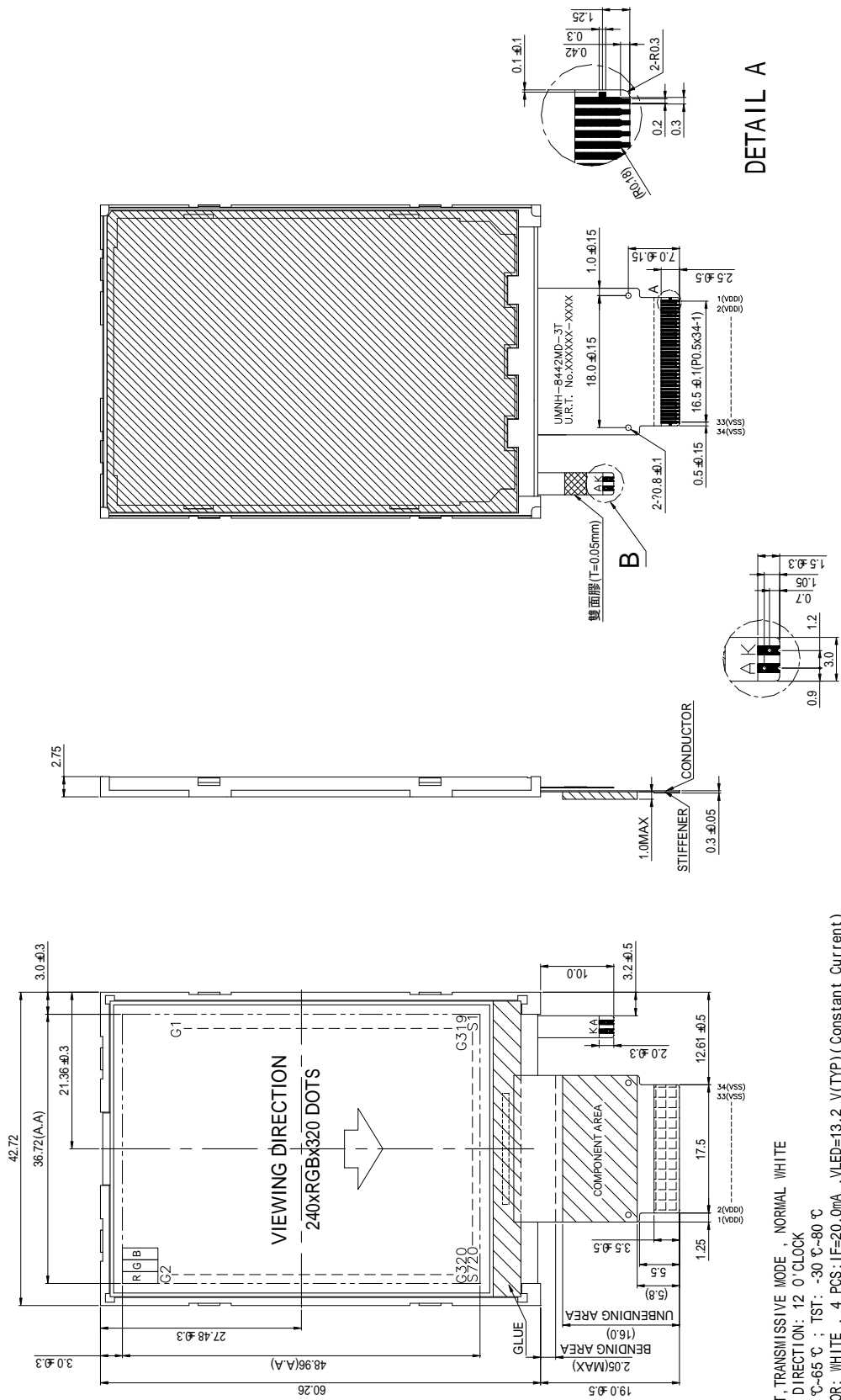

- NOTE :
1. LCD: TFT, TRANSMISSIVE MODE , NORMAL WHITE
 2. VIEWING DIRECTION : 12 O'CLOCK
 3. TOP: -20 C-65 C ; TST: -30 C-80 C
 4. LED COLOR: WHITE , 4 PCS; IF=20.0mA , VLED=13.2 V(TYP) (Constant Current)
 5. DRIVER IC: ILI9338
 6. TOLERANCE FOR NOT ASSIGNED : ±0.2 mm
 7. TFT PIXEL SIZE : 0.153 x 0.153 mm
 8. THE MINIMUM BENDABLE RADIUS(INNER) OF THE FPC IS 0.5 mm
 9. IF THE CUSTOMER BEND THE FPC INSIDE OF THE UNBENDING AREA, URT WON'T BE RESPONSIBLE FOR ANY DAMAGE
 10. LCM UNIFORMITY : 75% min
 11. THE LUMINANCE OF LCM : 250 cd/m² (TYP)

1.4 Block diagram:

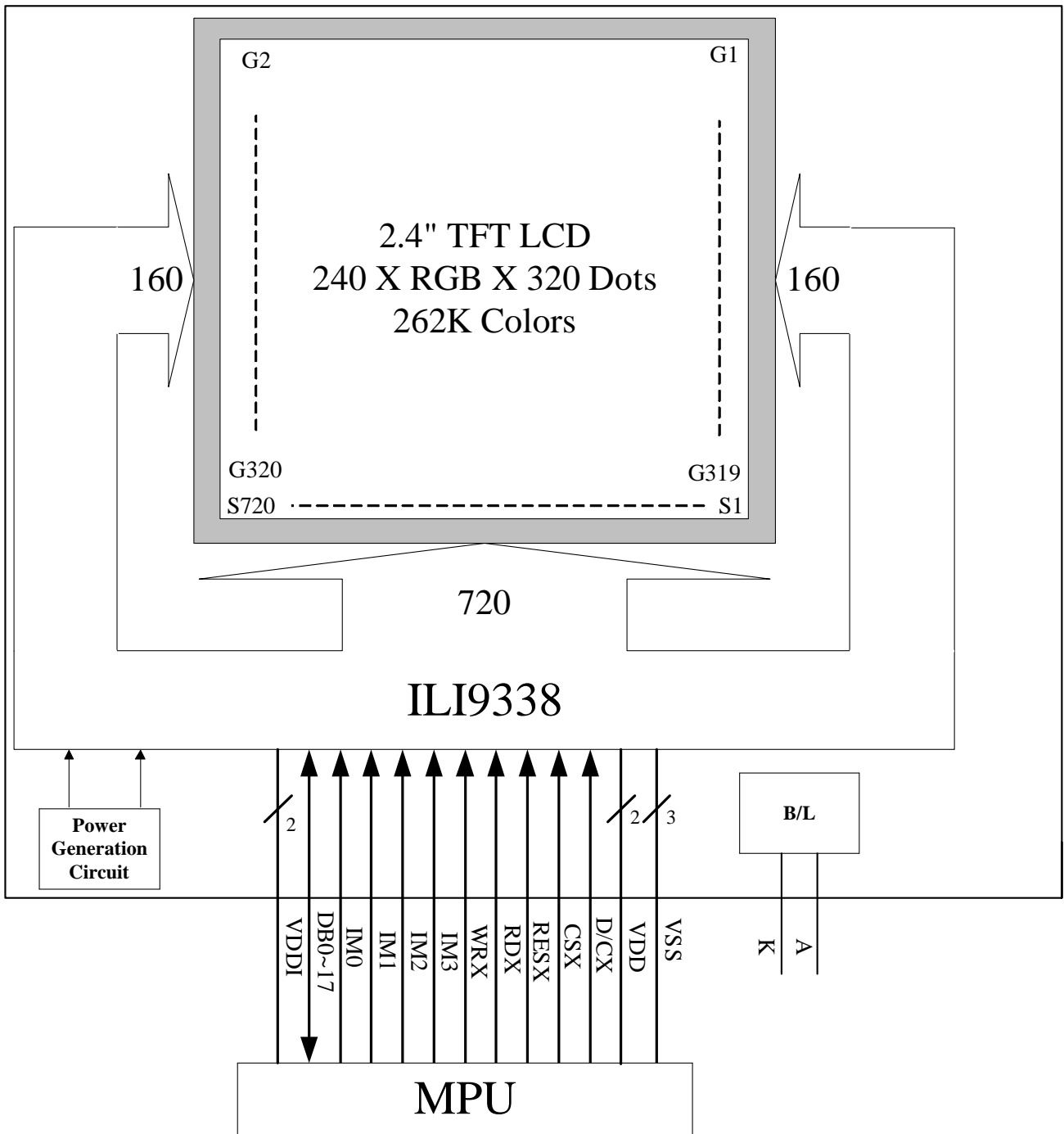

1.5 Interface pin :

Pin No.	Pin Symbol	I/O	Description																																																								
1~2	VDDI	P	Power supply for the I/O interface.: VDDI = (+2.8V).																																																								
3~20	DB0~17	I/O	An 18-bit parallel bi-directional data bus for MPU system interface mode. Fix to VSS level when not in use																																																								
21	IM0		Selects the MPU interface mode.																																																								
22	IM1		<table border="1"> <thead> <tr> <th>IM3</th> <th>IM2</th> <th>IM1</th> <th>IM0</th> <th>MPU-Interface Mode</th> <th>DB Pin in use</th> </tr> </thead> <tbody> <tr> <td>0</td> <td>0</td> <td>0</td> <td>0</td> <td>8080 MCU 16-bits Parallel type I</td> <td>DB[15:0]</td> </tr> <tr> <td>0</td> <td>0</td> <td>0</td> <td>1</td> <td>8080 MCU 8-bits Parallel type I</td> <td>DB[7:0]</td> </tr> <tr> <td rowspan="6">24</td> <td rowspan="6">IM3</td> <td>0</td> <td>0</td> <td>1</td> <td>0</td> <td>8080 MCU 16-bits Parallel type II</td> <td>DB[17:0]. DB[8:1]</td> </tr> <tr> <td>0</td> <td>0</td> <td>1</td> <td>1</td> <td>8080 MCU 8-bits Parallel type II</td> <td>DB[17:10]</td> </tr> <tr> <td>1</td> <td>0</td> <td>0</td> <td>0</td> <td>8080 MCU 18-bits Parallel type I</td> <td>DB[17:0]</td> </tr> <tr> <td>1</td> <td>0</td> <td>0</td> <td>1</td> <td>8080 MCU 9-bits Parallel type I</td> <td>DB[8:0]</td> </tr> <tr> <td>1</td> <td>0</td> <td>1</td> <td>0</td> <td>8080 MCU 18-bits Parallel type II</td> <td>DB[17:0]</td> </tr> <tr> <td>1</td> <td>0</td> <td>1</td> <td>1</td> <td>8080 MCU 9-bits Parallel type II</td> <td>DB[17:9]</td> </tr> </tbody> </table>	IM3	IM2	IM1	IM0	MPU-Interface Mode	DB Pin in use	0	0	0	0	8080 MCU 16-bits Parallel type I	DB[15:0]	0	0	0	1	8080 MCU 8-bits Parallel type I	DB[7:0]	24	IM3	0	0	1	0	8080 MCU 16-bits Parallel type II	DB[17:0]. DB[8:1]	0	0	1	1	8080 MCU 8-bits Parallel type II	DB[17:10]	1	0	0	0	8080 MCU 18-bits Parallel type I	DB[17:0]	1	0	0	1	8080 MCU 9-bits Parallel type I	DB[8:0]	1	0	1	0	8080 MCU 18-bits Parallel type II	DB[17:0]	1	0	1	1	8080 MCU 9-bits Parallel type II	DB[17:9]
IM3	IM2	IM1	IM0	MPU-Interface Mode	DB Pin in use																																																						
0	0	0	0	8080 MCU 16-bits Parallel type I	DB[15:0]																																																						
0	0	0	1	8080 MCU 8-bits Parallel type I	DB[7:0]																																																						
24	IM3	0	0	1	0	8080 MCU 16-bits Parallel type II	DB[17:0]. DB[8:1]																																																				
		0	0	1	1	8080 MCU 8-bits Parallel type II	DB[17:10]																																																				
		1	0	0	0	8080 MCU 18-bits Parallel type I	DB[17:0]																																																				
		1	0	0	1	8080 MCU 9-bits Parallel type I	DB[8:0]																																																				
		1	0	1	0	8080 MCU 18-bits Parallel type II	DB[17:0]																																																				
		1	0	1	1	8080 MCU 9-bits Parallel type II	DB[17:9]																																																				
23	IM2																																																										
25	WRX	I	8080 system (WRX): Serves as a write signal and writes data at the rising edge.																																																								
26	RDX	I	8080 system (RDX): Serves as a read signal and read data at the rising edge.																																																								
27	RESX	I	The external reset input. Initializes the chip with a low input. Be sure to execute a power-on reset after supplying power.																																																								
28	CSX	I	- A chip selection signal. Low: the chip is selected and accessible High: the chip is not selected and not accessible																																																								
29	D/CX	I	The signal for command or parameter select. Low: Command. High: Parameter.																																																								
30~31	VDD	P	Power supply for the analog circuit.. VDD= (+2.8V).																																																								
32~34	VSS	P	Power Supply for Ground (0V).																																																								

Backlight:

Pin No.	Pin Symbol	I/O	Description
1	A	P	Anode of the LED Backlight.
2	K	P	Cathode of the LED Backlight (0V).

2. ELECTRICAL CHARACTERISTICS

2.1 Absolute Maximum Ratings

Items	Symbol	Min.	Max.	Unit
Supply voltage (Logic)	VDDI	-0.3	+4.6	V
Supply voltage	VDD	-0.3	+4.6	V
Input voltage	V _i	-0.3	VDDI+0.3	V
Operating temperature range	T _{OP}	-20	+65	°C
Storage temperature range	T _{ST}	-30	+80	°C

2.2 DC Characteristics

Items	Symbol	Min.	Typ.	Max.	Unit	Condition
Analog Operating Voltage	VDD	2.5	2.8	3.3	V	NOTE
Logic Operating Voltage	VDDI	1.65	2.8	3.3	V	NOTE
Logic High Level Input Voltage	V _{IH}	0.7VDDI	-	VDDI	V	-
Logic Low Level Input Voltage	V _{IL}	VSS	-	0.3VDDI	V	-
Power supply current	I _{DD} +I _{DDI}	-	-	9	mA	NOTE

NOTE :

Measuring Condition :

Standard Value MAX.

T_a = 25°C

VDD-VSS = +2.8V

VDDI-VSS = +2.8V

Display Patten



0 gray black pattern

2-2.1 Back-light Characteristics

PARAMETER	SYMBOL	MIN	TYP	MAX	Unit	Test Condition	NOTE
Supply Current	I _f	-	20	-	mA	T _a =25°C I _f =20mA	-
Supply Voltage	V _F	-	13.2	-	V	T _a =25°C I _f =20mA	-
Half-Life Time	L _f	-	10000	-	hrs	T _a =25°C I _f =20mA	1

Note 1 : The “ Half-Life Time ” is defined as the module brightness decrease to 50% original brightness.

2.3 Command Sequence (Recommend by U.R.T.)

LCD_Initial_ILI9338:

Start Initial Sequence:

COMMAND	CODE	DESCRIPTION
--	LCD_RESET=1 delay 1ms LCD_RESET=0 delay 10ms LCD_RESET=1 delay 50ms	
11H	-	Sleep OUT
	delay 100ms	
CBH	01H	AP[2:0]
C0H	26H 01H	Power Control 1
C1H	44H	Power Control 2
C5H	2DH 38H	VCOM Control 1
26H	01H	Gamma Set
E0H	1FH 18H 16H 08H 10H 08H 45H 9BH 34H 2AH 0FH 07H 07H 07H 00H	Positive Gamma Correction

COMMAND	CODE	DESCRIPTION
E1H	00H 27H 29H 08H 0FH 07H 3AH 46H 4BH 15H 10H 08H 38H 38H 1FH	Negative Gamma Correction
29H	-	Display ON
2AH	00H 00H 00H EFH	Column Address Set
2BH	00H 00H 01H 3FH	Page Address Set
2AH	00H 00H 00H EFH	COLUMN ADDRESS SET
2BH	00H 00H 01H 3FH	ROW ADDRESS SET
3AH	05H	Pixel Format Set
2CH	-	Memory Write

2.4 AC Characteristics

2.4.1 Display Parallel 18/16/9/8-bit Interface Timing Characteristics (8080-system)

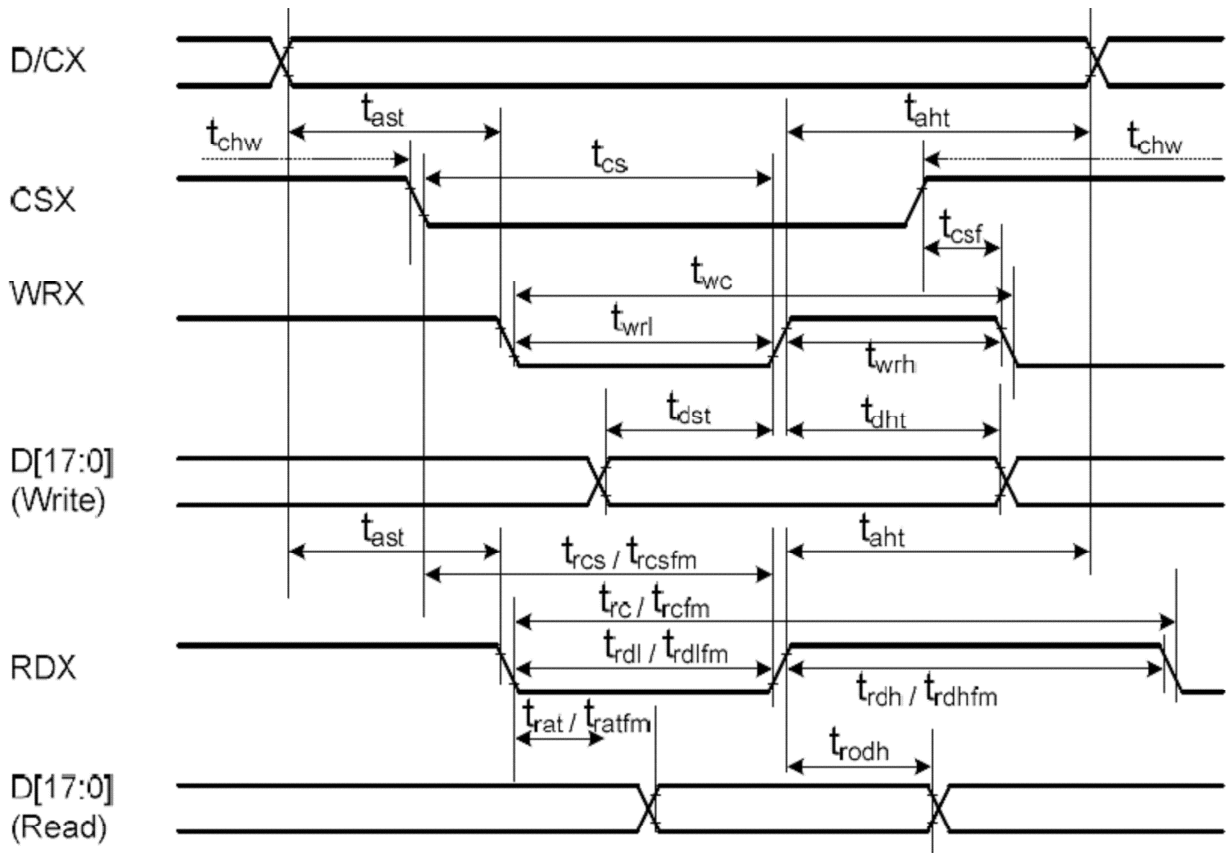

Signal	Symbol	Parameter	min	max	Unit	Description
DCX	tast	Address setup time	0	-	ns	
	taht	Address hold time (Write/Read)	10	-	ns	
CSX	tchw	CSX "H" pulse width	0	-	ns	
	tcs	Chip Select setup time (Write)	15	-	ns	
	trcs	Chip Select setup time (Read ID)	45	-	ns	
	trcsfm	Chip Select setup time (Read FM)	355	-	ns	
	tcsf	Chip Select Wait time (Write/Read)	10	-	ns	
WRX	twc	Write cycle	66	-	ns	
	twrh	Write Control pulse H duration	15	-	ns	
	twrl	Write Control pulse L duration	15	-	ns	
RDX (FM)	trcfm	Read Cycle (FM)	450	-	ns	
	trdhfm	Read Control H duration (FM)	90	-	ns	
	trdlfm	Read Control L duration (FM)	355	-	ns	
RDX (ID)	trc	Read cycle (ID)	160	-	ns	
	trdh	Read Control pulse H duration	90	-	ns	
	trdl	Read Control pulse L duration	45	-	ns	
D[17:0], D[15:0], D[8:0], D[7:0]	tdst	Write data setup time	10	-	ns	For maximum CL=30pF For minimum CL=8pF
	tdht	Write data hold time	10	-	ns	
	trat	Read access time	-	40	ns	
	tratfm	Read access time	-	340	ns	
	trod	Read output disable time	20	80	ns	

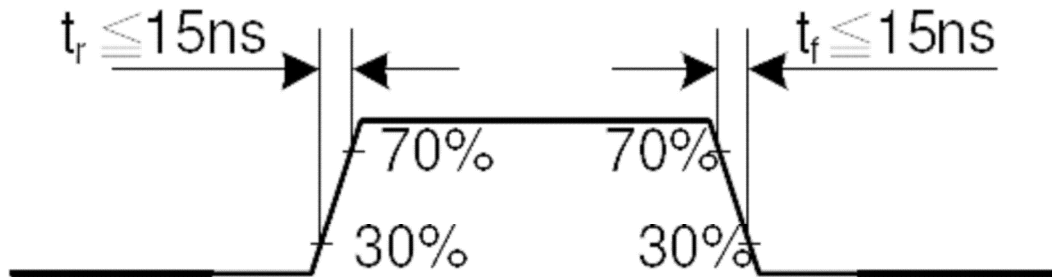

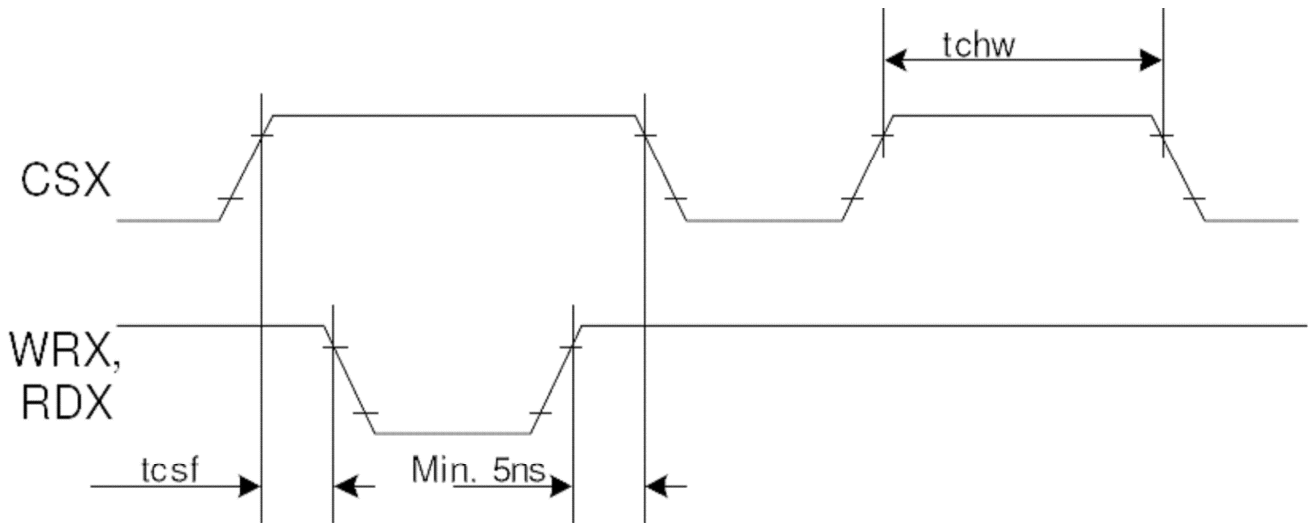

Note: Logic high and low levels are specified as 30% and 70% of VDDI for Input signals.

Write to read or read to write timings:

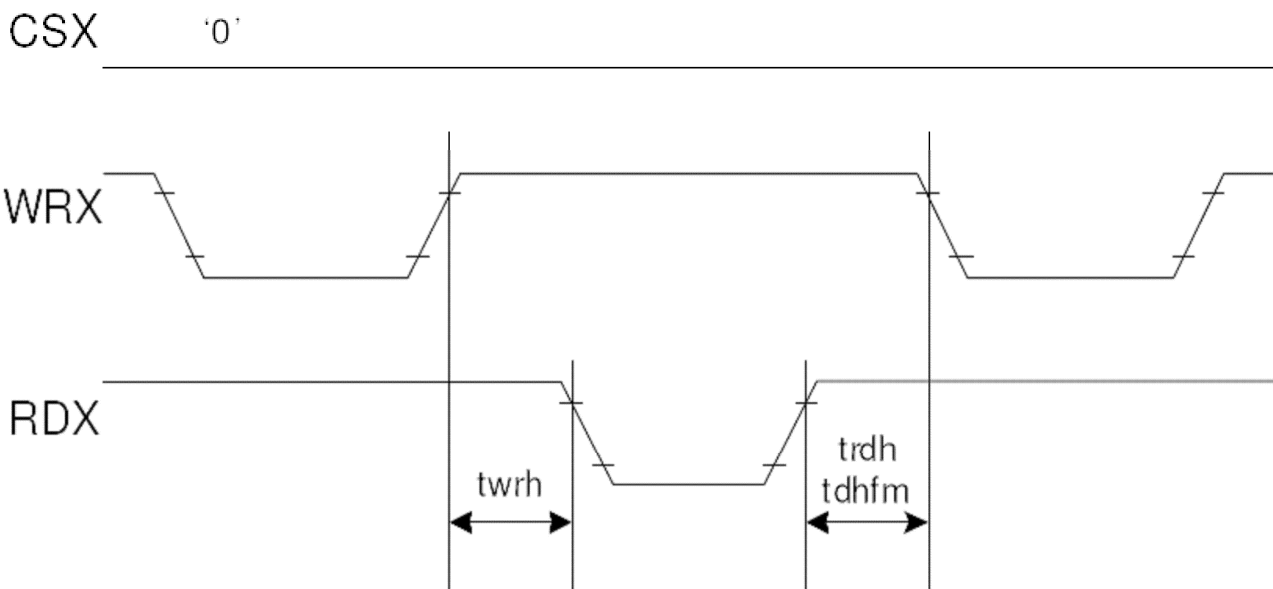

Note: Logic high and low levels are specified as 30% and 70% of VDDI for Input signals.

2.3.2 Reset Timing Characteristics

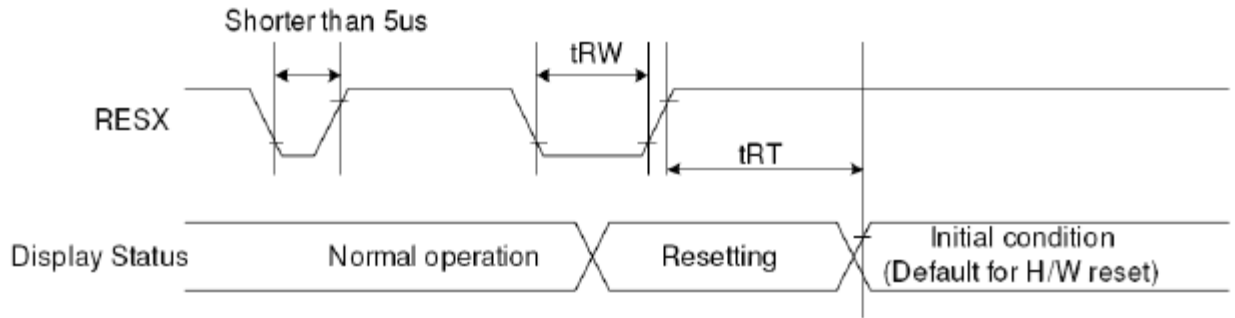

Signal	Symbol	Parameter	Min	Max	Unit
RESX	tRW	Reset pulse duration	10		uS
	tRT	Reset cancel		5 (note 1,5)	mS
				120 (note 1,6,7)	mS

Note 1: The reset cancel includes also required time for loading ID bytes, VCOM setting and other settings from NV memory to registers. This loading is done every time when there is HW reset cancel time (tRT) within 5 ms after a rising edge of RESX.

Note 2: Spike due to an electrostatic discharge on RESX line does not cause irregular system reset according to the table below:

RESX Pulse	Action
Shorter than 5us	Reset Rejected
Longer than 10us	Reset
Between 5us and 9us	Reset starts

Note 3: During the Resetting period, the display will be blanked (The display is entering blanking sequence, which maximum time is 120 ms, when Reset Starts in Sleep Out –mode. The display remains the blank state in Sleep In -mode.) And then return to Default condition for Hardware Reset.

Note 4: Spike Rejection also applies during a valid reset pulse as shown below:

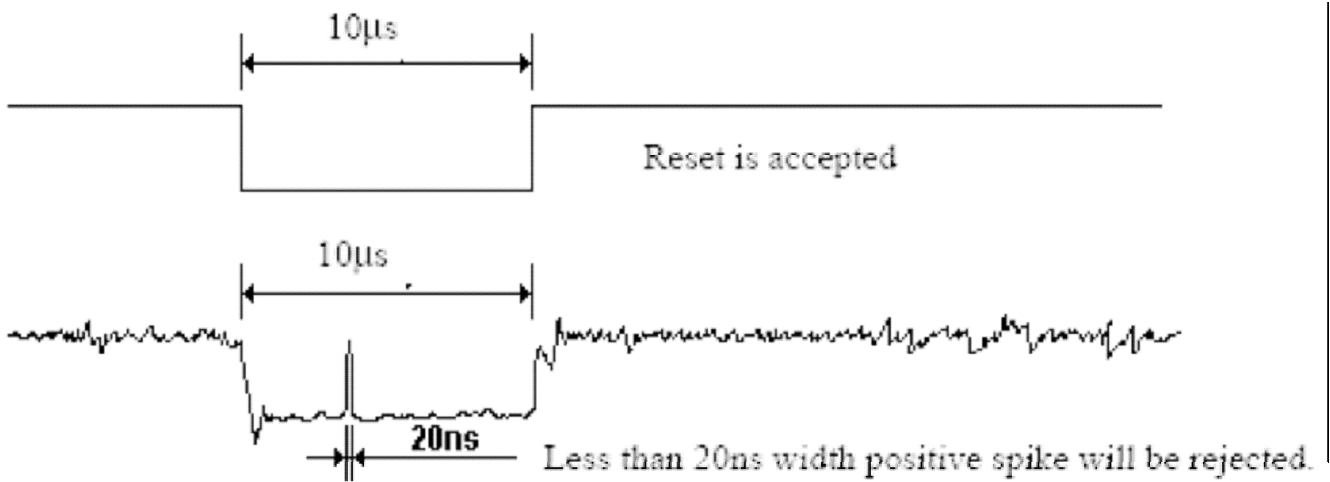

Note 5: When Reset applied during Sleep In Mode.

Note 6: When Reset applied during Sleep Out Mode.

Note 7: It is necessary to wait 5msec after releasing RESX before sending commands. Also Sleep Out command cannot be sent for 120msec.

3. OPTICAL CHARACTERISTICS

3.1 Characteristics

Electrical and Optical Characteristics

No.	Item		symbol / temp.		Min.	Typ.	Max.	Unit	Note	
1	Response Time		Ton+Toff	25 °C	-	30	-	ms	2	
2	Viewing Angle	Hor.	Cr>10	Θ_{2+}	0°	-	45	-	degree	3
				Θ_{2-}	180°	-	45	-		
		Ver.		Θ_{1+}	270°	-	35	-		
				Θ_{1-}	90°	-	15	-		
3	Contrast Ratio		Cr	25 °C	300	500	-	-	4	
4	Red x-code		Rx	25 °C	0.54	0.59	0.64	-	5	
	Red y-code		Ry		0.29	0.34	0.39			
	Green x-code		Gx		0.30	0.35	0.40			
	Green y-code		Gy		0.55	0.60	0.65			
	Blue x-code		Bx		0.09	0.14	0.19			
	Blue y-code		By		0.02	0.07	0.12			
	White x-code		Wx		0.24	0.29	0.34			
	White y-code		Wy		0.26	0.31	0.36			
	Brightness		Y		200	250	-	cd/m ²		
5	Brightness Uniformity			25 °C	75	-	-	%	6	

3.2 Definition of optical characteristics

Measurement condition :

Transmissive and Transflective type

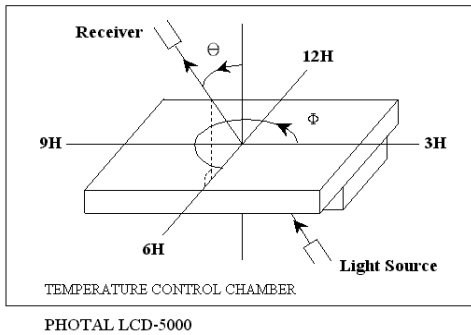

[Note 1] Definition of LCD Driving Vop and Waveform :

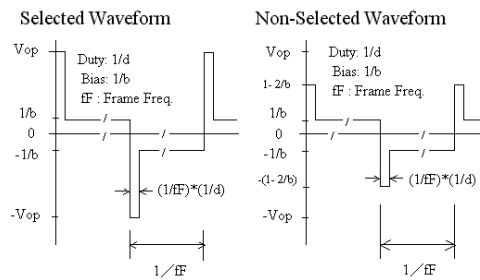
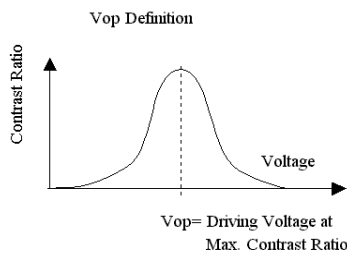

[Note 2] Definition of Response Time

for Positive type :

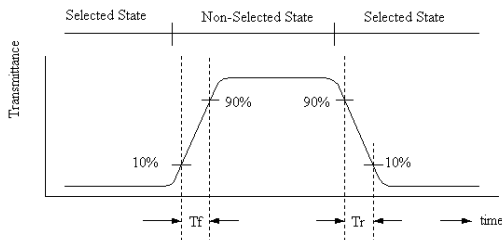

[Note 3] Definition of Viewing Angle :

[Note 4] Definition of Contrast Ratio :

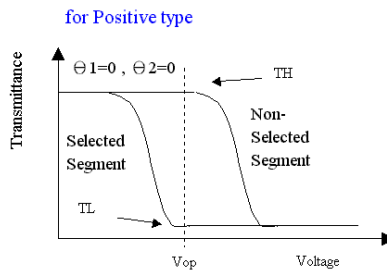
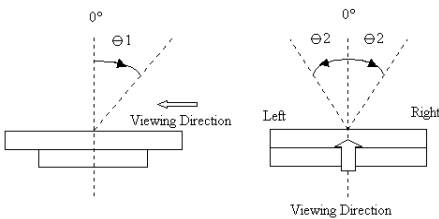

$$\text{Contrast Ratio} = \frac{TH}{TL}$$

[Note 5] Definition of measurement of Color Chromaticity and Brightness

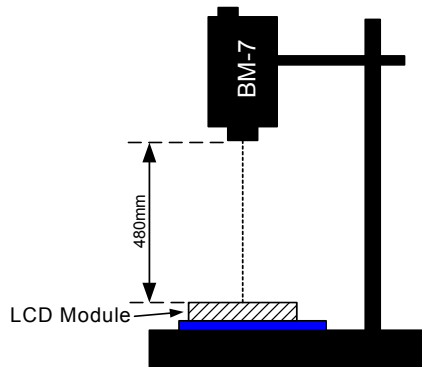

[Note 6] Definition of Brightness Uniformity

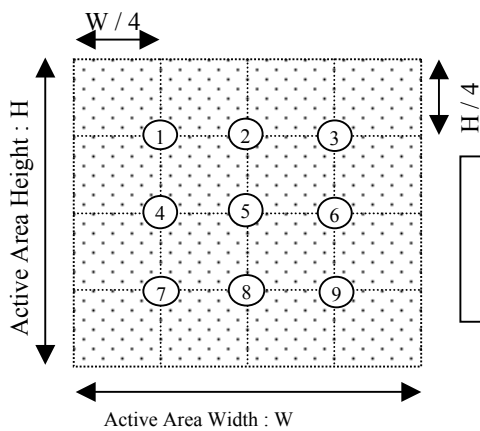

$$\text{Brightness Uniformity} = \frac{\text{Minimum Brightness of Point 1~9}}{\text{Maximum Brightness of Point 1~9}}$$

[Note 7] Definition of Measurement of Reflectance

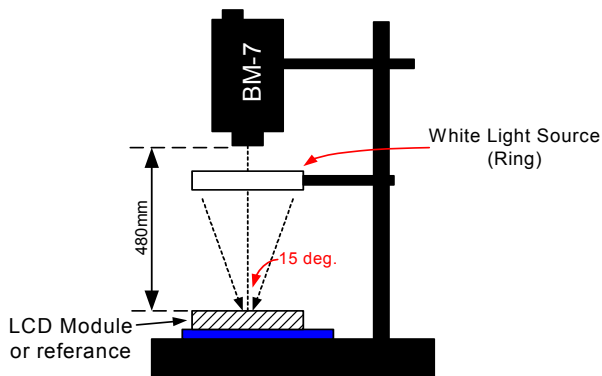

4. RELIABILITY :

Item No	Items	Condition
1	High temperature operating	65 , 200 hours
2	Low temperature operating	-20 , 200 hours
3	High temperature storage	80 , 200 hours
4	Low temperature storage	-30 , 200 hours
5	High temperature & humidity storage	60 , 90%RH, 100 hours
6	Thermal Shock storage	-30 , 30min.<=> 80 , 30min. 10 Cycles
7	Vibration test	10 => 55 =>10 => 55 => 10 Hz , within 1 minute Amplitude : 1.5mm. 15 minutes for each Direction (X,Y,Z)
8	Drop test	Packed, 100CM free fall, 6 sides, 1 corner, 3edges
9	Life time	50,000 hours 25 , 60%RH , specification condition driving

* One single product test for only one item.

* Judgment after test : keep in room temperature for more than 2 hours.

- Current consumption < 2 times of initial value
- Contrast > 1/2 initial value
- Function : work normally

5. PRODUCT HANDLING AND APPLICATION

PRECAUTION FOR HANDLING LCM

The LCD module contains a C-MOS LSI. People who operate the LCM should wear ESD protection equipment to prevent ESD hurt on products.

Do not input any signal before power is turned on.

Do not take LCM from its packaging bag until it is assembled.

Peel off the LCM protective film slowly since static electricity may be generated.

Pay attention to the humidity of the work shop, 50~60%RH is satisfactory.

Use a non-leak iron for soldering LCM.

Do not touch the display surface or connection terminals area with bare hands. Smudges on the display surface reduce the insulation between terminals.

Cautions for soldering to LCM:

Condition for soldering I/O terminals:

Temperature at iron tip :350 ±15 .

Soldering time : 3~4sec./ terminals.

Type of solder : Eutectic solder(rosin flux filled).

PRECAUTION IN USE OF LCD

Do not contact or scratch the front surface and the contact pads of a LCD panel with hard materials such as metal or glass or with one's nail.

To clean the surface , wipe it gently with soft cloth dampened by alcohol.

Do not attempt to wipe off the contact pads.

Keep LCD panels away from direct sunlight , also avoid them in high-temperature & high humidity environment for a long period.

Do not drive LCD panels by DC voltage.

Do not expose LCD panels to organic solvent.

Liquid in LCD is hazardous substance. In case a contact with liquid crystal material is occurred, be sure to immediately wash such material away by soap and water.

The polarizer is easily damaged and should be handle with special care. Don't press or rub it with hard objects.

PRECAUTION FOR STORING AND USE OF LCM

To avoid degradation of the device , do not store the module under the conditions of direct sunlight , high temperature or high humidity . Keep the module in bags designed to prevent static electricity charging under low temperature / normal humidity conditions(avoid high temperature / high humidity and low temperature below 0)

Never use the LCD , LCM under 45 Hz , the liquid crystal will decomposition and cause permanently damage on display !!

USING ON MEDICAL CARE , SAFETY OR HAZARDOUS APPLICATION OR SYSTEM

For the application in medical care, safety and hazardous products or systems, an authorization from URT is required. URT will not responsible for any damage or loss which caused by the products without any authorization given by URT.

This product is not allowed to be designed and used for military application and/or purpose.

The delivery of this product to the countries and/or regions where the embargoes are imposed by U.N. is prohibited.

The application and delivery of this product must comply with Strategic High-Tech Commodities (SHTC) export control and the sales to the embargoed and/or sanctioned countries or regions are strictly prohibited.

6. DATE CODE OF PRODUCTS

Date code will be shown on each product :

YY MM DD - XXXX
| | | |
Year Month Day - Production lots

Example: 090508 - 0 0 0 3 ==>Year 2009, May.,08rd , Batch no.03

7. PACKING

Instruction of lot number:

LOT NO. : 0 0 0 8 3 5 2 5 (EX)

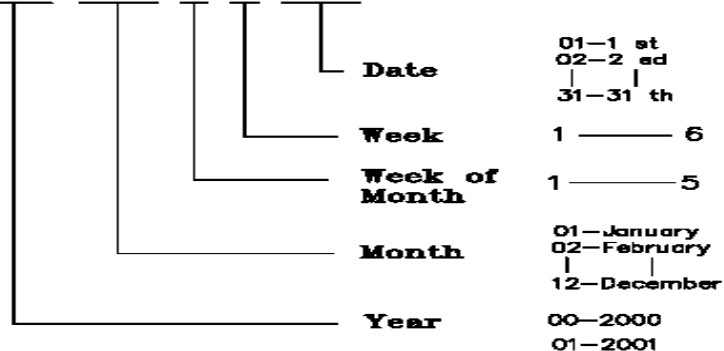

Lable of carton:

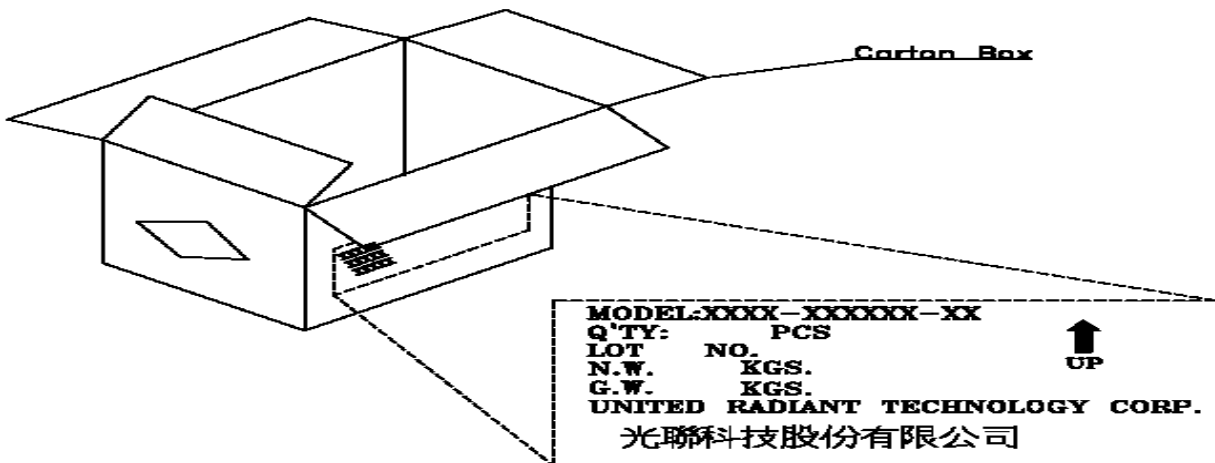

Packing tray must be stacked with alternated direction to each others.
To tacks packing trays in same direction will cause product damaged.

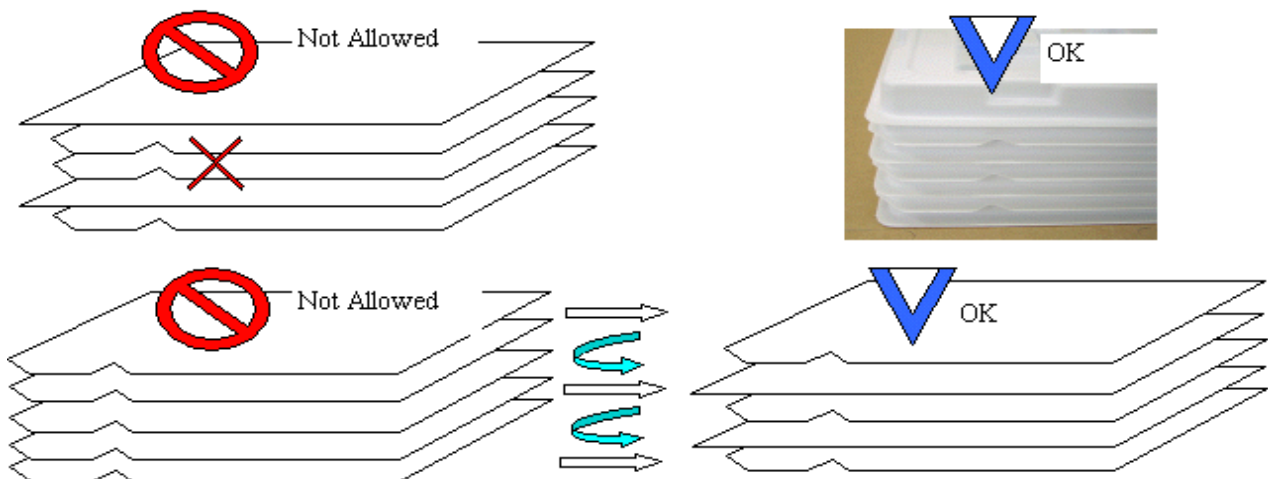

MODEL NO: UM*

T.B.D pcs / Tray

T.B.D Tray / Box

T.B.D. Box / Carton

T.B.D. pcs / Carton

NOTE:

- (1) Be warned, the direction of the tray has to turn it by 180 degree before stack it up. Otherwise, it will be packager's responsibility!!
- (2) Safe Stack : 5 cartons only

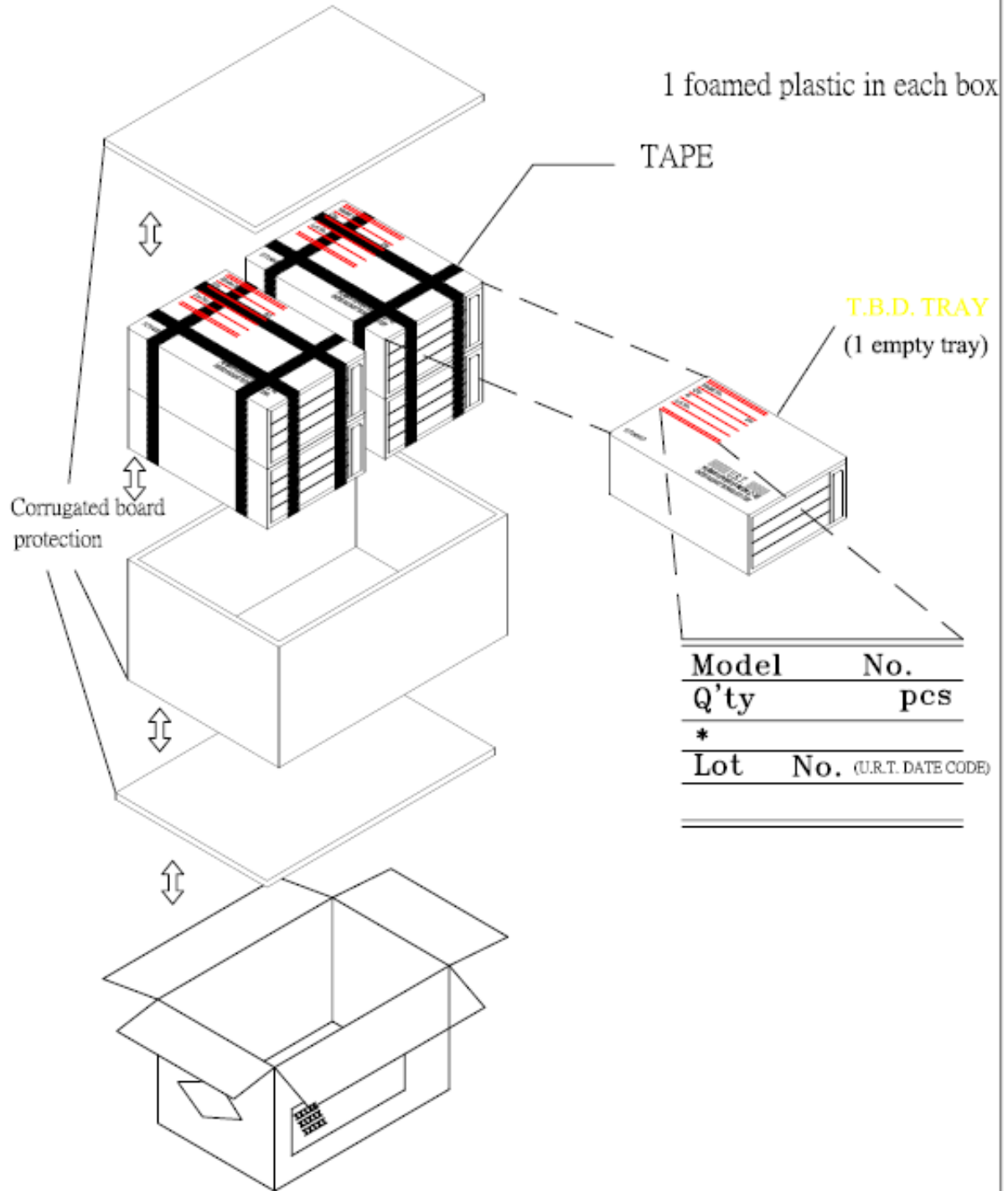

8. INSPECTION STANDARD

8.1. QUALITY :

THE QUALITY OF GOODS SUPPLIED TO PURCHASER SHALL COME UP TO THE FOLLOWING STANDARD.

8.1.1. THE METHOD OF PRESERVING GOODS

AFTER DELIVERY OF GOODS FROM U.R.T. TO PURCHASER. PURCHASER SHALL CONTROL THE LCM AT -10 40 ,AND IT MIGHT BE DESIRABLE TO KEEP AT THE NORMAL ROOM TEMPERATURE AND HUMIDITY UNTIL INCOMING INSPECTION OR THROWING INTO PROCESS LINE.

8.1.2. INCOMING INSPECTION

(A) THE METHOD OF INSPECTION

IF PURCHASER MAKE AN INCOMING INSPECTION , A SAMPLING PLAN SHALL BE APPLIED ON THE CONDITION THAT QUALITY OF ONE DELIVERY SHALL BE REGARDED AS ONE LOT.

(B) THE STANDARD OF QUALITY

ISO-2859-1 (or MIL-STD-105E) , LEVEL SINGLE PLAN.

CLASS	AQL(%)
CRITICAL	0.4 %
MAJOR	0.65 %
MINOR	1.5 %
TOTAL	1.5 %

EVERY ITEM SHALL BE INSPECTED ACCORDING TO THE CLASS.

(C) MEASURE

IF AS THE RESULT OF ABOVE RECEIVING INSPECTION , A LOT OUT IS DISCOVERED. PURCHASER SHALL BE INFORM SELLER OF IT WITHIN SEVEN DAYS. BUT FIRST SHIPMENT WITHIN FOURTEEN DAYS.

8.1.3. WARRANTY POLICY

U.R.T. WILL PROVIDE ONE-YEAR WARRANTY FOR THE PRODUCTS ONLY IF UNDER SPECIFICATION OPERATING CONDITIONS. U.R.T. WILL REPLACE NEW PRODUCTS FOR THESE DEFECT PRODUCTS WHICH UNDER WARRANTY PERIOD AND BELONG TO THE RESPONSIBILITY OF U.R.T.

8.2. CHECKING CONDITION

8.2.1. CHECKING DIRECTION SHALL BE IN THE 45 DEGREE AREA TO FACE THE SAMPLE.

8.2.2. CHECKER SHALL SEE OVER 30 cm. WITH BARE EYES FAR FROM SAMPLE AND USING 2 PCS. OF 20W FLUORESCENT LAMP.

8.3. INSPECTION PLAN :

CLASS	ITEM	JUDGEMENT	CLASS
PACKING & INDICATE	1. OUTSIDE AND INSIDE PACKAGE	"MODEL NO." , "LOT NO." AND "QUANTITY" SHOULD INDICATE ON THE PACKAGE.	Minor
	2. MODEL MIXED AND QUANTITY	OTHER MODEL MIXED.....REJECTED QUANTITY SHORT OR OVER.....REJECTED	Critical
	3. PRODUCT INDICATION	"MODEL NO." SHOULD INDICATE ON THE PRODUCT	Major
ASSEMBLY	4. DIMENSION, LCD GLASS SCRATCH AND SCRIBE DEFECT.	ACCORDING TO SPECIFICATION OR DRAWING.	Major
APPEARANCE	5. VIEWING AREA	POLARIZER EDGE OR LCD'S SEALING LINE IS VISABLE IN THE VIEWING AREAREJECTED	Minor
	6. BLEMISH, BLACK SPOT, WHITE SPOT IN THE LCD AND LCD GLASS CRACKS	ACCORDING TO STANDARD OF VISUAL INSPECTION (INSIDE VIEWING AREA)	Minor
	7. BLEMISH, BLACK SPOT WHITE SPOT AND SCRATCH ON THE POLARIZER	ACCORDING TO STANDARD OF VISUAL INSPECTION (INSIDE VIEWING AREA)	Minor
	8. BUBBLE IN POLARIZER	ACCORDING TO STANDARD OF VISUAL INSPECTION (INSIDE VIEWING AREA)	Minor
	9. LCD'S RAINBOW COLOR	STRONG DEVIATION COLOR (OR NEWTON RING) OF LCD.....REJECTED. OR ACCORDING TO LIMITED SAMPLE (IF NEEDED, AND INSIDE VIEWING AREA)	Minor
ELECTRICAL	10. ELECTRICAL AND OPTICAL CHARACTERISTICS (CONTRAST, VOP, CHROMATICITY ... ETC)	ACCORDING TO SPECIFICATION OR DRAWING . (INSIDE VIEWING AREA)	Critical
	11.MISSING LINE	MISSING DOT, LINE, CHARACTERREJECTED	Critical
	12.SHORT CIRCUIT, WRONG PATTERN DISPLAY	NON DISPLAY, WRONG PATTERN DISPLAY, CURRENT CONSUMPTION OUT OF SPECIFICATION..... REJECTED	Critical
	13. PIN HOLE, PATTERN DEFORMITY	ACCORDING TO STANDARD OF VISUAL INSPECTION	Minor

8.4. STANDARD OF VISUAL INSPECTION

NO.	CLASS	ITEM	JUDGEMENT																																	
8.4.1	MINOR	<p>. BLEMISH, BLACK SPOT, WHITE SPOT IN THE LCD.</p> <p>. BLEMISH, BLACK SPOT, WHITE SPOT AND SCRATCH ON THE POLARIZER</p>	<p>(A) ROUND TYPE: unit : mm.</p> <table border="1"> <thead> <tr> <th>DIAMETER (mm.)</th> <th>ACCEPTABLE Q'TY</th> </tr> </thead> <tbody> <tr> <td>0.1</td> <td>DISREGARD</td> </tr> <tr> <td>0.1 < 0.2</td> <td>2</td> </tr> <tr> <td>0.2 < 0.25</td> <td>1</td> </tr> <tr> <td>0.25 <</td> <td>0</td> </tr> </tbody> </table> <p>NOTE: $=(\text{LENGTH}+\text{WIDTH})/2$</p> <p>(B) LINER TYPE: unit : mm.</p> <table border="1"> <thead> <tr> <th>LENGTH</th> <th>WIDTH</th> <th>ACCEPTABLE Q'TY</th> </tr> </thead> <tbody> <tr> <td>-----</td> <td>W 0.03</td> <td>DISREGARD</td> </tr> <tr> <td>L 5.0</td> <td>0.03 < W 0.05</td> <td>3</td> </tr> <tr> <td>L 5.0</td> <td>0.05 < W 0.07</td> <td>1</td> </tr> <tr> <td>-----</td> <td>0.07 < W</td> <td>FOLLOW ROUND TYPE</td> </tr> </tbody> </table>	DIAMETER (mm.)	ACCEPTABLE Q'TY	0.1	DISREGARD	0.1 < 0.2	2	0.2 < 0.25	1	0.25 <	0	LENGTH	WIDTH	ACCEPTABLE Q'TY	-----	W 0.03	DISREGARD	L 5.0	0.03 < W 0.05	3	L 5.0	0.05 < W 0.07	1	-----	0.07 < W	FOLLOW ROUND TYPE								
DIAMETER (mm.)	ACCEPTABLE Q'TY																																			
0.1	DISREGARD																																			
0.1 < 0.2	2																																			
0.2 < 0.25	1																																			
0.25 <	0																																			
LENGTH	WIDTH	ACCEPTABLE Q'TY																																		
-----	W 0.03	DISREGARD																																		
L 5.0	0.03 < W 0.05	3																																		
L 5.0	0.05 < W 0.07	1																																		
-----	0.07 < W	FOLLOW ROUND TYPE																																		
8.4.2	MINOR	BUBBLE IN POLARIZER	<p style="text-align: right;">unit : mm.</p> <table border="1"> <thead> <tr> <th>DIAMETER</th> <th>ACCEPTABLE Q'TY</th> </tr> </thead> <tbody> <tr> <td>0.15</td> <td>DISREGARD</td> </tr> <tr> <td>0.15 < 0.5</td> <td>2</td> </tr> <tr> <td>0.5 <</td> <td>0</td> </tr> </tbody> </table>	DIAMETER	ACCEPTABLE Q'TY	0.15	DISREGARD	0.15 < 0.5	2	0.5 <	0																									
DIAMETER	ACCEPTABLE Q'TY																																			
0.15	DISREGARD																																			
0.15 < 0.5	2																																			
0.5 <	0																																			
8.4.3	MINOR	Dot Defect	<table border="1"> <thead> <tr> <th>Items</th> <th>ACC. Q'TY</th> </tr> </thead> <tbody> <tr> <td>Bright dot</td> <td>N 4</td> </tr> <tr> <td>Dark dot</td> <td>N 4</td> </tr> </tbody> </table> <p>Pixel Define</p> <table border="1"> <tbody> <tr> <td>R</td><td>G</td><td>B</td><td>R</td><td>G</td><td>B</td><td>R</td><td>G</td><td>B</td> </tr> <tr> <td>R</td><td>G</td><td>B</td><td>R</td><td>G</td><td>B</td><td>R</td><td>G</td><td>B</td> </tr> <tr> <td>R</td><td>G</td><td>B</td><td>R</td><td>G</td><td>B</td><td>R</td><td>G</td><td>B</td> </tr> </tbody> </table> <p>Not 1: The definition of dot: The size of a defective dot over 1/2 of whole dot is regarded as one defective dot. Not 2: Bright dot: Dots appear bright and unchanged in size in which LCD panel is displaying under black pattern. Not 3: Dark dot: Dots appear dark and unchanged in size in which LCD panel is displaying under pure red, green, blue pattern.</p>	Items	ACC. Q'TY	Bright dot	N 4	Dark dot	N 4	R	G	B	R	G	B	R	G	B	R	G	B	R	G	B	R	G	B	R	G	B	R	G	B	R	G	B
Items	ACC. Q'TY																																			
Bright dot	N 4																																			
Dark dot	N 4																																			
R	G	B	R	G	B	R	G	B																												
R	G	B	R	G	B	R	G	B																												
R	G	B	R	G	B	R	G	B																												

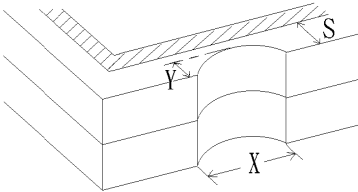
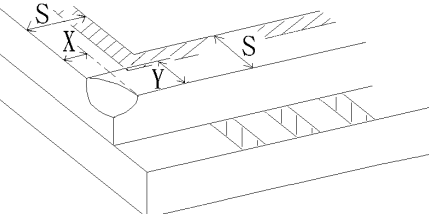
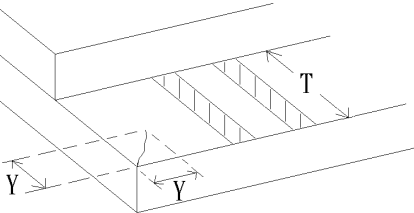
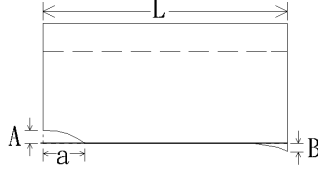
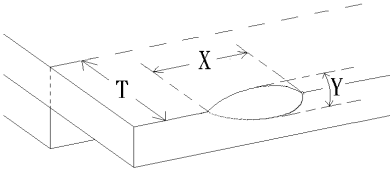
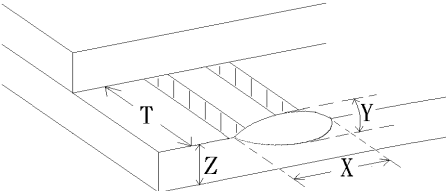
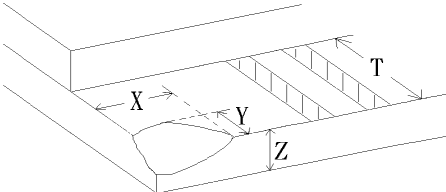
NO.	CLASS	ITEM	JUDGEMENT
8.4.4	MINOR	CHIPPING	 $Y > S$ REJ.
8.4.5	MINOR	CHIPPING	 $X \text{ or } Y > S$ REJ.
8.4.6	MAJOR	GLASS CRACK	 $Y > (1/2) T$ REJ.
8.4.7	MAJOR	SCRIBE DEFECT	 <ol style="list-style-type: none"> $a > L/3$, $A > 1.5\text{mm}$. REJ. B : ACCORDING TO DIMENSION
8.4.8	MINOR	CHIPPING (ON THE TERMINAL AREA)	 $= (x+y)/2 > 2.5 \text{ mm}$ REJ.
8.4.9	MINOR	CHIPPING (ON THE TERMINAL SURFACE)	 $Y > (1/3) T$ REJ.
8.4.10	MINOR	CHIPPING	 $Y > T$ REJ.