



UMY1N

Preliminary

DUAL TRANSISTOR

DUAL TRANSISTOR

DESCRIPTION

The UTC **UMY1N** is a dual transistor, including a NPN and a PNP which have common emitters. it uses UTC's advanced technology to provide customers with high DC current gain, etc.

FEATURES

- * PNP and NPN transistors have common emitters
- * High DC current gain

EQUIVALENT CIRCUIT

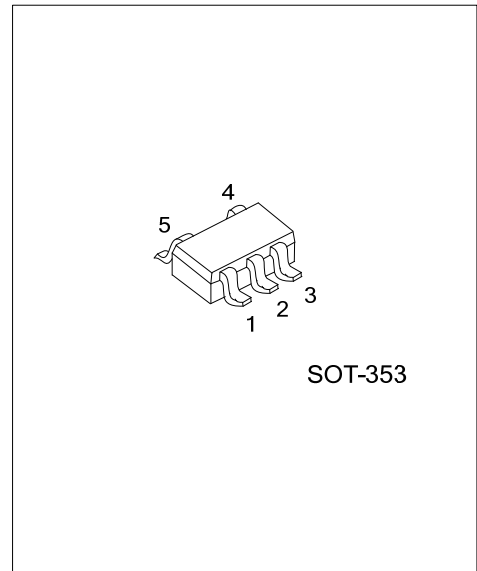
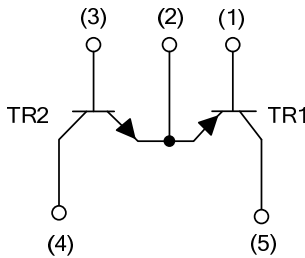

ORDERING INFORMATION

Order Number		Package	Pin Assignment					Packing
Lead Free	Halogen Free		1	2	3	4	5	
UMY1NL-AL5-R	UMY1NG-AL5-R	SOT-353	B1	E1, E2	B2	C2	C1	Tape Reel

<p>UMY1NL-AL5-R</p> <ul style="list-style-type: none"> (1) Packing Type (2) Package Type (3) Lead Free 	<ul style="list-style-type: none"> (1) R: Tape Reel (2) AL5: SOT-353 (3) L: Lead Free, G: Halogen Free
---	---

MARKING INFORMATION

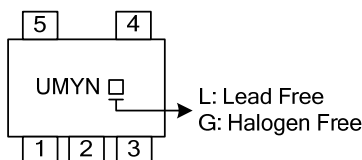

■ ABSOLUTE MAXIMUM RATINGS ($T_A=25^{\circ}\text{C}$, unless otherwise specified)

PARAMETER	SYMBOL	RATINGS		UNIT
		TR1	TR2	
Collector-Base Voltage	V_{CBO}	-60	60	V
Collector-Emitter Voltage	V_{CEO}	-50	50	V
Emitter-Base Voltage	V_{EBO}	-6	7	V
Continuous Collector Current	I_C	-150	150	mA
Collector Power Dissipation	P_C	150		mW
Junction Temperature	T_J	150		$^{\circ}\text{C}$
Storage Temperature	T_{STG}	-55~+150		$^{\circ}\text{C}$

Note: Absolute maximum ratings are those values beyond which the device could be permanently damaged. Absolute maximum ratings are stress ratings only and functional device operation is not implied.

■ ELECTRICAL CHARACTERISTICS ($T_A=25^{\circ}\text{C}$, unless otherwise specified)

PARAMETER	SYMBOL	TEST CONDITIONS	MIN	TYP	MAX	UNIT
TR1						
Collector-Base Breakdown Voltage	BV_{CBO}	$I_C=-50\mu\text{A}$, $I_E=0$	-60			V
Collector-Emitter Breakdown Voltage	BV_{CEO}	$I_C=-1\text{mA}$, $I_B=0$	-50			V
Emitter-Base Breakdown Voltage	BV_{EBO}	$I_E=-50\mu\text{A}$, $I_C=0$	-6			V
Collector Cut-Off Current	I_{CBO}	$V_{CB}=-60\text{V}$, $I_E=0$			-0.1	μA
Emitter Cut-Off Current	I_{EBO}	$V_{EB}=-6\text{V}$, $I_C=0$			-0.1	μA
Collector-Emitter Saturation Voltage	$V_{CE(SAT)}$	$I_C=-50\text{mA}$, $I_B=-5\text{mA}$			-0.5	V
DC Current Gain	h_{FE}	$V_{CE}=-6\text{V}$, $I_C=-1\text{mA}$	120		560	
Transition Frequency	f_T	$V_{CE}=-12\text{V}$, $I_E=-2\text{mA}$, $f=100\text{MHz}$		140		MHz
Output Capacitance	C_{ob}	$V_{CB}=-12\text{V}$, $I_E=0$, $f=1\text{MHz}$			5	pF
TR2						
Collector-Base Breakdown Voltage	BV_{CBO}	$I_C=50\mu\text{A}$, $I_E=0$	60			V
Collector-Emitter Breakdown Voltage	BV_{CEO}	$I_C=1\text{mA}$, $I_B=0$	50			V
Emitter-Base Breakdown Voltage	BV_{EBO}	$I_E=50\mu\text{A}$, $I_C=0$	7			V
Collector Cut-Off Current	I_{CBO}	$V_{CB}=60\text{V}$, $I_E=0$			0.1	μA
Emitter Cut-Off Current	I_{EBO}	$V_{EB}=7\text{V}$, $I_C=0$			0.1	μA
Collector-Emitter Saturation Voltage	$V_{CE(SAT)}$	$I_C=50\text{mA}$, $I_B=5\text{mA}$			0.4	V
DC Current Transfer Ratio	h_{FE}	$V_{CE}=6\text{V}$, $I_C=1\text{mA}$	120		560	
Transition Frequency	f_T	$V_{CE}=12\text{V}$, $I_E=2\text{mA}$, $f=100\text{MHz}$		180		MHz
Output Capacitance	C_{ob}	$V_{CB}=12\text{V}$, $I_E=0$, $f=1\text{MHz}$			3.5	pF

UTC assumes no responsibility for equipment failures that result from using products at values that exceed, even momentarily, rated values (such as maximum ratings, operating condition ranges, or other parameters) listed in products specifications of any and all UTC products described or contained herein. UTC products are not designed for use in life support appliances, devices or systems where malfunction of these products can be reasonably expected to result in personal injury. Reproduction in whole or in part is prohibited without the prior written consent of the copyright owner. The information presented in this document does not form part of any quotation or contract, is believed to be accurate and reliable and may be changed without notice.