

UN300 – Ultrasonic Sensor with LED Display



- ▶ 4-digit LEDs display, all-metal housing
- ▶ Rotatable indicator, PNP/NPN programmable
- ▶ 4..20mA/0...20mA/1...5V/0...5V output programmable
- ▶ Liquid level / distance measuring mode programmable
- ▶ Narrow-beam, applicable to liquid and solids
- ▶ Optional intrinsically safe model



UN300 contains an ultrasonic transmitter and an electronic module, the transmitter transmits ultrasonic pulses towards the level surface. The period during individual pulses spread towards the level and back was obtained and subsequently converted by the electronic module to an output current 4 – 20 mA or voltage 0 – 10V. All-metal housing, rotatable highlight LED display, dual keys design, user friendly menu, 330° rotatable indicator.

Specifications

Measuring Range	0.06...0.5m/0.10...0.80m/0. 20...2.00m/0.30...3.50m
Applicable Medium	Solids or liquid
Beamwidth	7°
Response Time	For details please see 'technical data'
Accuracy	≤0.2% of F.S. or ±2mm
Power Supply	12...30Vdc
Current Consumption	≤40mA (power supply 24Vdc, no-load)
Switching Output	
Output	Push-pull (compatible with PNP / NPN); NC / NO configurable
S1, S2 Output Current	<500mA
Voltage Drop	<1V
Current Analog Output	
Output	3-wire 0...20mA / 4...20mA programmable
Load RA	RA≤0.5KΩ
Voltage Analog Output	
Output	3-wire 0...5V / 1...5V programmable
Load RA	RA>10KΩ
Linearity	≤±0.2% of F.S.
Wiring Protection	Reverse polarity, overvoltage and short-circuit
Display	
Design/Display Range	8mm height, red 4-digit LED / -1999...9999
Temperature	
Operating/Storage	-20...+85°C
Material	
Display Head	Zinc Alloy
Housing/Sensor	316 stainless steel/epoxy resin, POM
Protection Class	IP67
Electrical Connection	M12×1 plug

Applications

- ▶ Food & pharmaceutical industry
- ▶ Power plant
- ▶ Plastics processing
- ▶ Papermaking
- ▶ Water treatment

Technical Data

Measuring Range(m)	0.06...0.50	0.10...0.80	0.20...2.00	0.30...3.50
Response Time(ms)	100	100	250	400
Resolution(mm)	0.5	0.8	1	1
Dead Zone(mm)	60	100	200	300

LEVEL

Set panel

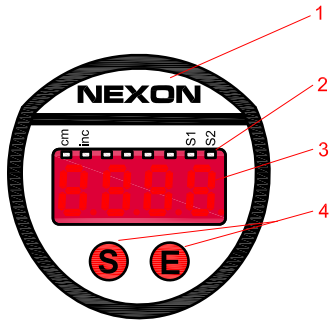

- 1 - LOGO
- 2 - 8 state lights
- 3 - 4-digit LED display window
- 4 - Keys

S + E	Press and hold for 2 seconds to enter setting mode/verification
S	Shift down the menu / change values
E	Shift up the menu / change setting position

Menu

Display	Item	Description	Options
unit	unit	unit	cm/inch
SP1	SP1	set point of output 1	2% ...100% of F.S.
rP1	rP1	reset point of output 1	lower limit ... 98% of F.S.
out1	out1	output mode	hysteresisNC/NO window NC/NO
SP2	SP2	set point of output 2	2% ...100% of F.S.
rP2	rP2	reset point of output 2	lower limit ...98% of F.S.
out2	out2	output mode	hysteresisNC/NO window NC/NO
SFun	sfun	output function	PNP / NPN

Display	Item	Description	Options
Aout	Aout	current analog output	0...20mA or 4...20mA
		voltage analog output	0...5V or 1...5V
ASt	Ast	analog output start point	lower limit ...75% of F.S.
AEd	AEd	analog output end point	25%...100% of F.S.
mode	Mode	operating mode	distance or level measuring
Sto	Sto	save	Yes/No

Functional specifications

Hysteresis Mode

The hysteresis keeps the switching output stable if the measured value fluctuates around the setpoint. Output switches when rising measured value reaches set point (SP1); As measured value falls, the output switches back only if the reset point (rP1) is reached.

Window Mode

The window function allows the monitoring of a defined range. If the measured value is between set point (SP1) and reset point (rP1), the output is activated(NO), otherwise it is deactivated(NC).

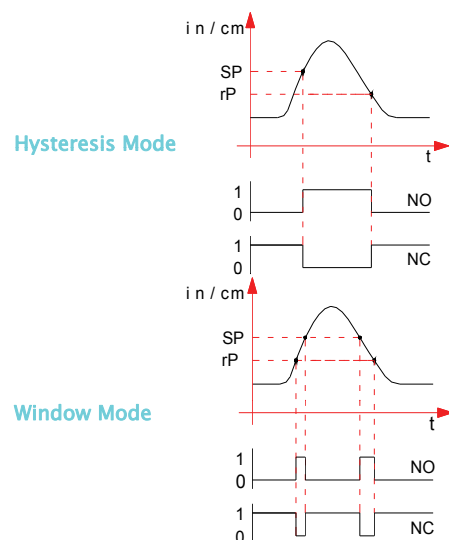

Working Mode

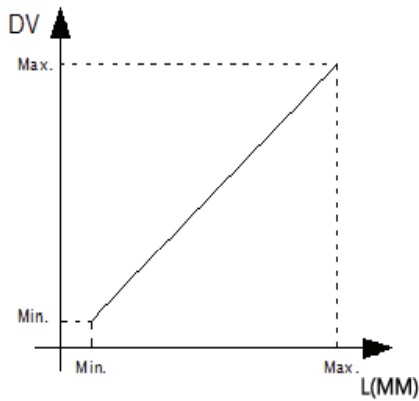

L : distance from sensor to objective surface
 DV : display value

Distance measuring mode : The further distance between sensor and objective surface, the larger value displayed, and vice versa.

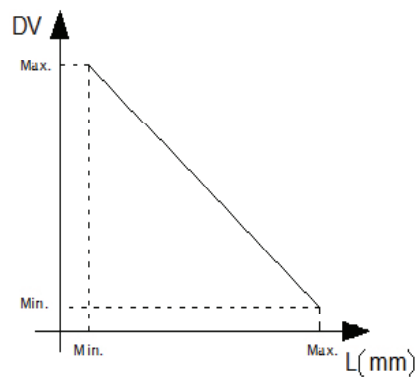

L : distance from sensor to objective surface
 DV : display value

Level measuring mode : The less distance between sensor and objective surface, the larger value displayed, and vice versa.

Wiring

Signal	Plug	Cable
U+	1	Brown
U-	3	Blue
Switching output S1	4	Black
Switching output S2	2	White
Analog output (Current or Voltage)	5	Gray

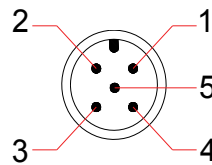

	PNP output	NPN output
2xPNP		
2xPNP + analog output		

Dimensions in inches (mm)

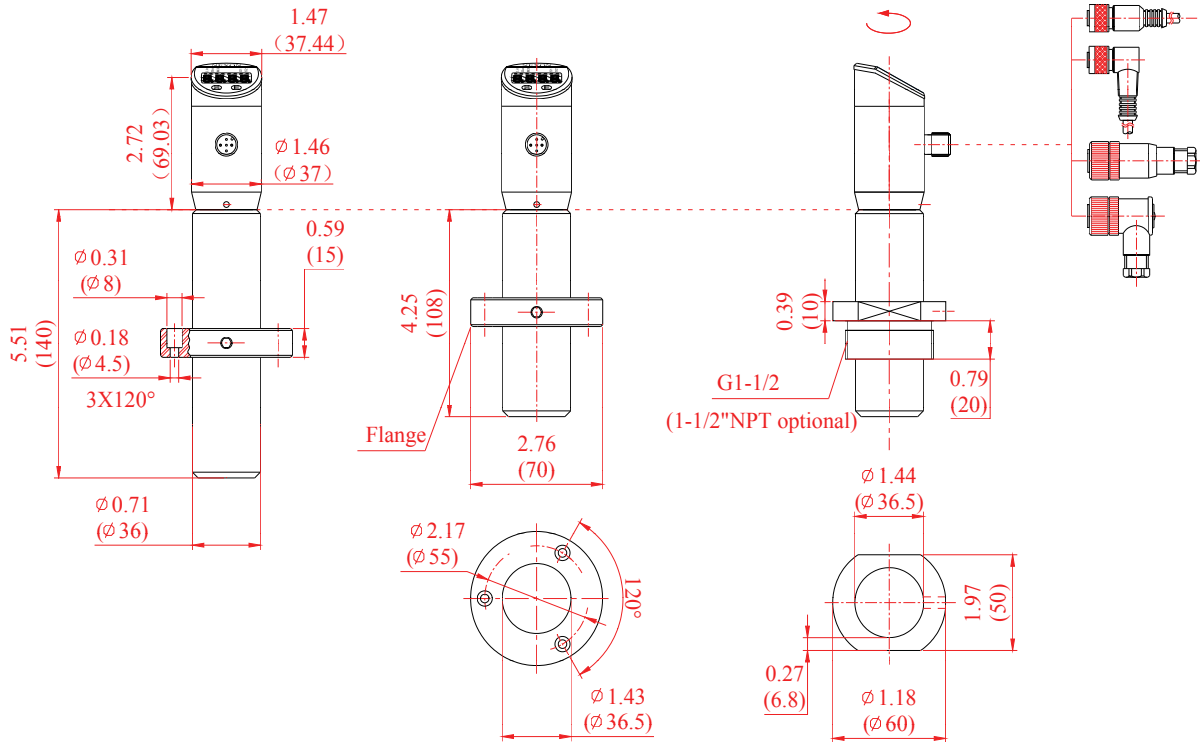

Order Code

UN :	Ultrasonic sensor with digital display
300 :	Series#
20 :	2 switching outputs
21 :	2 switching outputs + 1 analog (0...20/4...20mA) output
22 :	2 switching outputs + 1 analog (0...5/1...5V) output
F :	Flange connection
G :	G1-1/2 male thread
N :	1-1/2"NPT male thread

UN	300/	21/	F	S	M0.5	/
-----------	-------------	------------	----------	----------	-------------	----------

- S :** M12X1 5-pin plug
- C :** Cable outlet
- MXXX :** The upper limit of measuring range(metric system) xxx m
- IXXX :** The upper limit of measuring range(english system) xxx inch
- Note:** M0.5 means that the measuring range is 0.06...0.5m.
- Others**

Special Order on Request

- Electrical and / or process connection

LEVEL