

SONY®

VIDEO GRAPHIC PRINTER

UP-895

UP-895CE

UP-895MD

SERVICE MANUAL

1st Edition

⚠ 警告

このマニュアルは、サービス専用です。

お客様が、このマニュアルに記載された設置や保守、点検、修理などを行うと感電や火災、人身事故につながる可能性があります。

危険をさけるため、サービストレーニングを受けた技術者のみご使用ください。

⚠ WARNING

This manual is intended for qualified service personnel only.

To reduce the risk of electric shock, fire or injury, do not perform any servicing other than that contained in the operating instructions unless you are qualified to do so. Refer all servicing to qualified service personnel.

⚠ WARNUNG

Die Anleitung ist nur für qualifiziertes Fachpersonal bestimmt.

Alle Wartungsarbeiten dürfen nur von qualifiziertem Fachpersonal ausgeführt werden. Um die Gefahr eines elektrischen Schlages, Feuergefahr und Verletzungen zu vermeiden, sind bei Wartungsarbeiten strikt die Angaben in der Anleitung zu befolgen. Andere als die angegebenen Wartungsarbeiten dürfen nur von Personen ausgeführt werden, die eine spezielle Befähigung dazu besitzen.

⚠ AVERTISSEMENT

Ce manuel est destiné uniquement aux personnes compétentes en charge de l'entretien. Afin de réduire les risques de décharge électrique, d'incendie ou de blessure n'effectuer que les réparations indiquées dans le mode d'emploi à moins d'être qualifié pour en effectuer d'autres. Pour toute réparation faire appel à une personne compétente uniquement.

Table of Contents

1. Operating Instructions

2. Service Information

2-1.	Board Layout	2-1
2-2.	Disassembly	2-1
2-3.	Removal of Major Parts	2-2
2-3-1.	Removal of Mechanical Block	2-2
2-3-2.	Removal of MA-99 Board	2-3
2-3-3.	Removal of Switching Regulator	2-3
2-3-4.	Removal of Thermal Head	2-4
2-4.	Tightening the Screws	2-5
2-5.	Installation of Fan Motor	2-6

3. Electrical Alignment

3-1.	AGC Adjustment	3-1
3-2.	Video Level Adjustment	3-1
3-3.	Brightness and Contrast Adjustment	3-2
3-4.	Head Voltage Adjustment	3-3
3-5.	Initialization of Print Count History	3-3

4. Circuit Operation Description

4-1.	Video Circuit	4-3
4-1-1.	BNC Input Connector - Trap Filter Circuit	4-3
4-1-2.	nC-SYNC Generator Circuit	4-3
4-1-3.	AGC Circuit	4-3
4-1-4.	Brightness and Contrast Control	4-3
4-1-5.	A/D Conversion and D/A Conversion	4-3
4-2.	Clock Generator Circuit	4-4
4-3.	Memory and Head Control Circuit	4-4
4-3-1.	Reading the Serial Data from System Control	4-5
4-3-2.	Writing in Frame Memory	4-5
4-3-3.	Transfer from Frame Memory to Line Memory	4-5
4-3-4.	Thermal Head Control and One-Line Memory	4-5

4-4.	System Control Section	4-8
4-4-1.	Reading of Keys	4-8
4-4-2.	Reading of Function Switches	4-8
4-4-3.	Platen Motor Control	4-9
4-4-4.	Head Up and Down Control	4-10
4-4-5.	Monitor of Door Sensor	4-10
4-4-6.	Monitor of Paper Sensor	4-10
4-4-7.	Monitor of Head Temperature Sensor	4-11
4-4-8.	Control of Head Fan Motor (for Head Cooling)	4-11
4-4-9.	Control of Video Circuit Section	4-11
4-4-10.	Control of Memory and Head Control Circuit	4-12
4-4-11.	Gamma Correction and Thermal Storage Correction	4-13
4-4-12.	Discrimination of Video Signal to be Input	4-13
4-4-13.	Remote Interface	4-13
4-4-14.	Storage of Print Count History	4-13
4-5.	Thermal Head Section	4-14
4-5-1.	Structure	4-14
4-5-2.	Basic Operation	4-15
4-5-3.	Stair Generation	4-15
4-5-4.	Temperature Correction	4-16
4-5-5.	Line Count Correction	4-16

5. Troubleshooting

5-1.	Print is Faulty	5-1
5-2.	Print is Too Dark or Too Light	5-2
5-3.	“Paper Sensor” is Out of Order	5-3
5-4.	Head Operation (Up & Down) is Out of Order	5-4
5-5.	Paper Feeding is Out of Order	5-5
5-6.	Door (Opening and Closing) is Out of Order	5-6

6. Service Mode (Self-diagnostic Function)

6-1.	Printing the Test Pattern	6-1
6-2.	Up/Down Operation of Head	6-2
6-3.	Feed Operation	6-2
6-4.	Display and Clearing of Print Sheet History	6-3

7. Semiconductor Pin Assignments

8. Spare Parts

8-1. Notes on Repair Parts	8-1
8-2. Exploded Views	8-2
8-3. Electrical Parts List	8-7

9. Block Diagram

Overall	9-1
---------------	-----

10. Schematic Diagrams and Board Layouts

FRAME	10-2
KY-454	10-2
SE-531	10-2
SE-532	10-2
SU-52	10-2
MA-99	10-4

Video Graphic Printer

Instructions for Use Page 20

GB

Section 1 Operating Instructions

This section is extracted
from operation manual.

(For UP-895MD/895CE)

UP-895
UP-895MD
UP-895CE

© 1999 Sony Corporation

WARNING

To prevent fire or shock hazard, do not expose the unit to rain or moisture.

To avoid electrical shock, do not open the cabinet. Refer servicing to qualified personnel only.

THIS APPARATUS MUST BE EARTHED.

For UP-895MD/895CE

Symbol on the products



This symbol indicates the equipotential terminal which brings the various parts of a system to the same potential.



This symbol is intended to alert the user to the presence of important operating and maintenance (servicing) instructions in the literature accompanying the appliance.

For the customers in the U.S.A. (for UP-895/895MD)

This equipment has been tested and found to comply with the limits for a Class A digital device, pursuant to Part 15 of the FCC Rules. These limits are designed to provide reasonable protection against harmful interference when the equipment is operated in a commercial environment. This equipment generates, uses, and can radiate radio frequency energy and, if not installed and used in accordance with the instruction manual, may cause harmful interference to radio communications. Operation of this equipment in a residential area is likely to cause harmful interference in which case the user will be required to correct the interference at his own expense.

You are cautioned that any changes or modifications not expressly approved in this manual could void your authority to operate this equipment.

This device requires shielded interface cables to comply with FCC emission limits.

For the customers in Canada (for UP-895MD)

This unit has been certified according to Standard CSA C22.2 NO.601.1.

For UP-895MD/895CE

Important safeguards/notices for use in the medical environments

- All the equipments connected to this unit shall be certified according to Standard IEC601-1, IEC950, IEC65 or other IEC/ISO Standards applicable to the equipments.
- When this unit is used together with other equipment in the patient area*, the equipment shall be either powered by an isolation transformer or connected via an additional protective earth terminal to system ground unless it is certified according to Standard IEC601-1.

* Patient Area

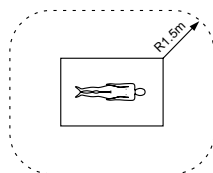

- The leakage current could increase when connected to other equipment.
- This equipment generates, uses, and can radiate frequency energy. If it is not installed and used in accordance with the instruction manual, it may cause interference to other equipment. If this unit causes interference (which can be determined by unplugging the power cord from the unit), try these measures: Relocate the unit with respect to the susceptible equipment. Plug this unit and the susceptible equipment into different branch circuit. Consult your dealer. (According to Standard EN60601-1-2 and CISPR11, Class B, Group 1)

Caution

When you dispose of the unit or accessories, you must obey the law in the relative area or country and the regulation in the relative hospital.

Table of Contents

Introduction

Overview 21

Preparation

Connection 22

Setting Up the Printer 22

Setting the Slide Switches on the Paper Tray 22

Setting the DIP Switches on the Rear Panel 23

Paper 25

Loading Paper 26

Operation

Printing 27

Making Printouts 27

Selecting the Printing Direction/Image Size 28

Adjusting the Contrast and Brightness 30

Remotely Controlling the Printer 30

Others

Precautions 31

Maintenance 31

Specifications 32

Troubleshooting 34

Location and Function of Parts 35

Front 35

Back 36

Overview

The UP-895/895MD/895CE is a black and white video graphics printer that can be used to print images displayed on a video monitor.

This manual covers the UP-895/895MD/895CE models. Wherever the operation or any other item differs among the models, this manual clearly describes those differences.

Clear, consistent print quality

- High definition, 12.8 dots/mm printing using a thermal head with a high-speed drive IC.
- 256 gradations of black and white.
- Stable printouts using temperature compensation technology

Fast printing

- You can make an A-7 size single printout in about 3.9 seconds in STD and NORM mode.
- You can make a maximum of 11 copies of the same image continuously.

Two way printing direction and various image sizes

- The printing direction selector on the front panel enables you to print in vertical and horizontal directions.
- The image size selector on the front panel enables you to select various printing size.

DIP switches and slide switches to optimize the printer

- You can adjust printout quality and select the paper type by setting the slide switches.
- You can make printouts starting either from the bottom or top of the image by setting the DIRECTION of DIP switch.
- You can set the printout aspect ratio to 4:3 or 1:1 by setting the ASPECT of DIP switch.
- You can set the range to be printed by setting the SCAN DIP switch.
- You can save paper by setting the POSTFEED DIP switch (paper saving function).

Automatic video signal determination

The type of input signal, black and white (EIA or CCIR) or input color (NTSC or PAL), is automatically determined and printed in the same duration and size.

Alarm buzzer

The alarm buzzer prevents you from making any mistakes.

Easy and quick paper loading

You can load paper just by opening the door and placing the paper roll.



Connection

Notes

- Turn off the power to each device before making any connections.
- Connect the AC power cord last.

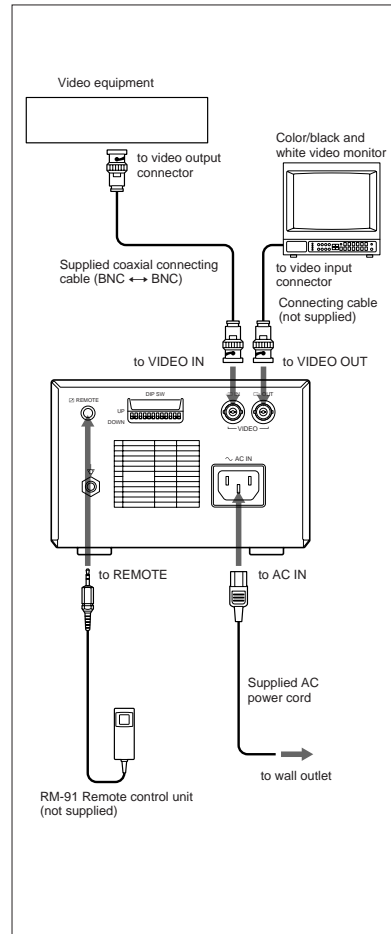

Setting Up the Printer

You can set the printer to the desired specifications using two kinds of switches.

- Slide switches on the paper tray inside the front door
 - You can easily set the printer specifications most frequently used in daily operation, such as selection of the paper type and printout quality.
- DIP switches on the rear panel
 - You can set the print mode and other settings you do not need to change frequently

Setting the Slide Switches on the Paper Tray

The factory settings are as follows.

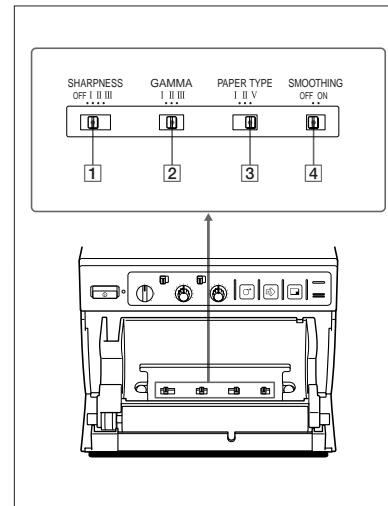

1 SHARPNESS switch

Adjusts the sharpness of the printout.

OFF: Not to emphasize an outline of the printout, set the switch to this position.

I, II, III: To make a sharper outline, set the switch to the proper position. In I, II and III order, the printout becomes sharper.

2 GAMMA switch

Sets the tone of printouts (density gradation).

I: Soft gradation

II: Standard

III: Hard gradation

The diagram below shows the curve of density gradation for each tone.

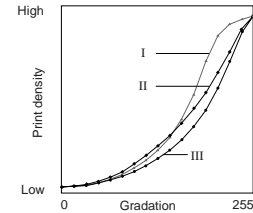

Note

This switch is effective only when you use paper types UPP-110HD or UPP-110HG, that is, when the PAPER TYPE switch **3** is set to either II or V.

3 PAPER TYPE switch

Selects the paper type.

Set the switch to the type of paper to be used.

Type of paper Switch position

UPP-110S I (Normal)

UPP-110HD II (High density)

UPP-110HG V (High glossy)

4 SMOOTHING switch

Selects the line density.

OFF: Normally keep this switch to this position.

ON: To set the print line density to high density and obtain the better print quality, set the switch to this position. However, the printing speed is slower than at the OFF position.

Note

This switch becomes effective under the following conditions.

- When the image size selector on the front panel is set to either SML or NOR and STD/SIDE selector is set to STD, and ASPECT of DIP switch **3** on the rear panel is set to 4 : 3.
- When the image size selector is set to a position other than SML and NOR and ASPECT of DIP switch **3** is set to 1 : 1.

Under any other conditions except those above, the print line density is not set to high and the print quality is standard even if you set the switch to ON.

Setting the DIP Switches on the Rear Panel

To change the DIP switch settings

Use a small pointed tool such as a small screwdriver.

The factory settings are as follows.

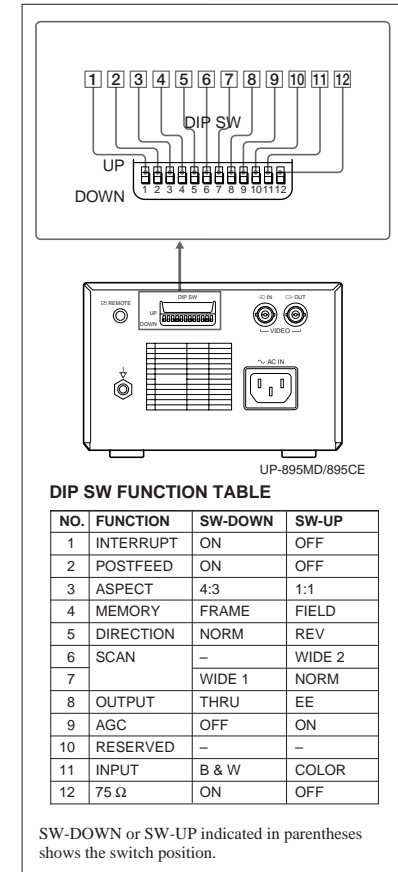

DIP SW FUNCTION TABLE

NO.	FUNCTION	SW-DOWN	SW-UP
1	INTERRUPT	ON	OFF
2	POSTFEED	ON	OFF
3	ASPECT	4:3	1:1
4	MEMORY	FRAME	FIELD
5	DIRECTION	NORM	REV
6	SCAN	—	WIDE 2
7		WIDE 1	NORM
8	OUTPUT	THRU	EE
9	AGC	OFF	ON
10	RESERVED	—	—
11	INPUT	B & W	COLOR
12	75 Ω	ON	OFF

SW-DOWN or SW-UP indicated in parentheses shows the switch position.

1 INTERRUPT switch

Sets whether the PRINT button is activated to enable interruption of the printing process and capture an image in memory.

ON (SW-DOWN): Interrupts the printing currently under way and prints a new picture when you press the PRINT button during printing.

OFF (SW-UP): Disregards the fact that the PRINT button is pressed during printing and continues the printing currently under way. If you press the PRINT button during printing in the OFF mode, the alarm buzzer will sound.

2 POSTFEED switch

Sets extra blank paper once an image has been printed. **ON (SW-DOWN):** Feeds out extra blank paper once an image has been printed.

OFF (SW-UP): Does not feed out extra blank paper once an image has been printed.

To save paper by feeding only a short length of paper after printing an image, set this switch to OFF. In this way, you can make more printouts per roll of paper, but you have to feed the paper manually using the FEED button and tear off the paper. When you make multiple copies of the same printout, this position is effective in helping to save paper.

3 ASPECT 4:3/1:1 switch

Normally keep this switch set to 4:3 (SW-DOWN).

When the aspect ratio of the video signal is 1:1, set it to 1:1 (SW-UP).

The printout will be longer than a printout made at 4:3.

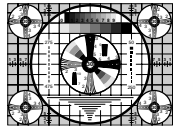

4:3

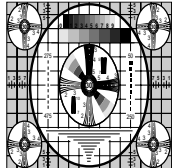

1:1

4 MEMORY switch

FRAME (SW-DOWN): Normally keep this switch set to this position.

FIELD (SW-UP): When printing fast-moving images (such as a ball being thrown), the printout may blur. If this happens, set the switch to this position. The printout definition will be poorer but less blurred.

5 DIRECTION switch

Selects whether the top or bottom of the screen is to be printed first.

NORM (SW-DOWN): Normally keep this switch set to this position. Printing is done from the bottom of the screen.

REV (SW-UP): Starts printing from the top of the screen.

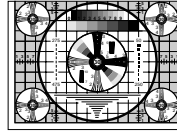

NORM

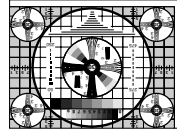

REV

6/7 SCAN switch

Sets the printout range. The printout range is progressively widened in the NORM, WIDE 1, and WIDE 2 order.

NORM (Switch 7, SW-UP position): Prints only the image displayed on the standard screen size of the video monitor.

WIDE 1 (Switch 7, SW-DOWN position): Prints when the signal scans beyond the edge of the standard monitor screen.

WIDE 2 (Switch 6, SW-UP position): To further extend the range, select this setting.

When you set Switch 6 to the SW-UP position (WIDE 2 position), WIDE 2 is selected regardless of the setting of SCAN switch 7.

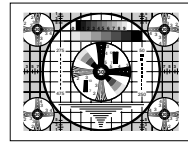

NORM

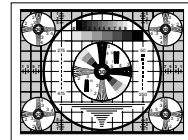

WIDE 1

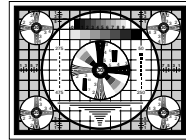

WIDE 2

8 OUTPUT switch

Selects the video signal output from the VIDEO OUT connector on the rear panel.

THRU (SW-DOWN): Signals are output directly to the video monitor.

EE (SW-UP): Signals are output to the video monitor after being processed by the printer.

9 AGC (Automatic Gain Control) switch

Adjusts the input signal to the optimum printing level. **OFF (SW-DOWN):** Normally keep this switch set to this position.

ON (SW-UP): When the printout image appears too dark or too light, set the switch to this position to adjust the input signal to the optimum level.

10 RESERVED switch

Keep this switch set to the factory setting (SW-DOWN)

11 INPUT switch

B & W (SW-DOWN): When the signal to be printed is black and white, set the switch to this position.

COLOR (SW-UP): When the signal is color, set the switch to this position.

12 75 Ω ON/OFF switch

ON (SW-DOWN): When nothing is connected to the VIDEO OUT connector, set the switch to this position.

OFF (SW-UP): When a video monitor or other video equipment is connected to the VIDEO OUT connector, set the switch to this position.

Example:

When you connect two printers to one piece of video equipment, set the 75Ω switch of one of the printers to ON, and the other to OFF.

When you connect the printer and a video monitor to the video equipment, set the 75Ω switch to OFF.

Paper

Use only UPP-110S/110HD/110HG paper as specified for the UP-895/895MD/895CE. If another type of paper is used, the quality of the printout cannot be guaranteed. Use of another type of paper may also cause malfunction of the printer. You cannot use the UPP-110HA paper as specified for the UP-880/890MD/890CE.

Type of paper

The following types of paper are available.

Printing quality	Type of paper
TYPE I (Normal)	UPP-110S
TYPE II (High Density)	UPP-110HD
TYPE V (High Glossy)	UPP-110HG

Notes on paper

Storing unused paper

Avoid storing unused paper in a location subject to the following. Storage of unused paper in such a place results in deterioration of unused paper.

- Store unused paper in a cool and dark place (below 30°C or 86°F).
- Do not store unused paper in a hot or humid place. Do not leave unused paper in direct sunlight or other bright places.
- Do not allow any volatile organic solvent or vinyl chloride to touch unused paper. Alcohol, plastic tape or film will deteriorate unused paper.

When loading paper

- Do not fold the paper or touch the printing surface. Dust or finger prints are likely to cause poor print quality.
- Before loading the paper roll, remove the label attached to the top of paper roll and pull out the first 15 to 20 cm (6 to 8 inches). The label mark is likely to cause poor print quality.

Storing printouts

- Avoid storing printouts in a location subject to the following. Storage of your printouts in such a place results in fading of printouts.
 - Store printouts in a cool and dark place (below 30°C or 86°F). We recommend storing printouts in a bag made of clay-free paper or polypropylene.
 - Do not store printouts in a hot or humid place. Do not leave printouts in direct sunlight or other bright places.
 - Do not allow any volatile organic solvent or vinyl chloride to touch printouts. Alcohol, plastic tape or film will cause the printout to fade.
- Do not stack your printouts on or under a diazo copy sheet. Also do not attach the printed surface to another printed surface. The printout may become discolored.
- To attach the printout to another piece of paper, use double-sided adhesive tape or water-based glue.



Loading Paper

Notes

- Before loading paper, read "Paper" on page 25.
- Do not fold the paper or touch the printing surface. Dust or finger prints are likely to cause poor print quality.
- Use only UPP-110S/110HD/110HG paper as specified for this printer. (page 25)
- Set the PAPER TYPE switch according to the paper type. (page 23)

Loading

- 1 Press the power switch to turn on the printer. The power lamp lights.

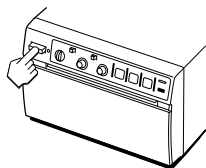

- 2 Press the OPEN button to open the door.

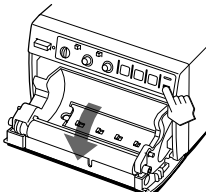

- 3 Remove the label attached at the top of the paper roll, pull out the first 15 to 20 cm (6 to 8 inches) of the paper, then place the paper roll in the paper tray.

Note

When pulling out the top of the paper roll or placing it in the paper tray, be careful not to drop the paper roll. If dust has accumulated on the paper, you may not be able to use this paper because dust or finger prints are likely to cause poor print quality or malfunction of the head.

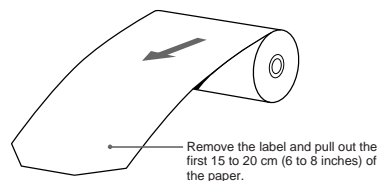

Place the paper with the thermo-sensitive side (printing side) up. If you place the paper with the printing side down by mistake, the image will not be printed.

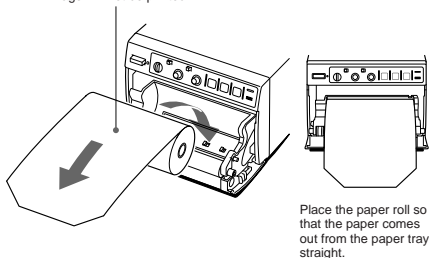

- 4 Close the door by pushing it.

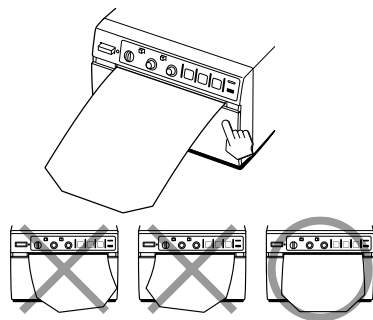

Note

- If the paper roll is not placed properly and does not come out from the paper tray straight, this may cause paper jamming.
- If you did not pull out the paper enough in step 3, feed the paper at least 15 to 20 cm by pressing and holding down the FEED button. **Do not pull out the paper manually.**

Printing

Before making printouts

Confirm the following:

- Are the connections correct? (page 22)
- Are the slide switches and DIP switches set correctly? (pages 22 and 23)
- Is the paper type set correctly? (page 23)
- Is the paper roll loaded properly? (page 26)
- Is the video source being input?

Making Printouts

- 1 Press the power switch to turn on the printer.

The power lamp lights and the EMPTY lamp blinks for a few seconds.

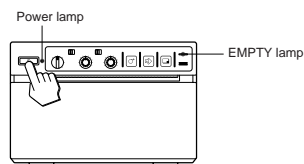

Note

Make sure that the EMPTY lamp turns out after blinking for a few seconds. If lit, the paper has run out. Load the paper. ("Loading Paper" on page 26)

- 2 Select the printing direction and image size. See "Selecting the Printing Direction/Image Size" on the next page.

- 3 Start the video source.

This operation is done using the controls of the video equipment which you are using as a source.

- 4 When the image you want to print is on the video monitor, press the PRINT button.

The image displayed at the instant you press the PRINT button is captured into memory and is printed out immediately.

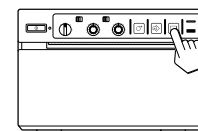

To interrupt printing

Press either the OPEN or FEED button while printing. The printer stops printing.

To stop printing and print another image displayed on the video monitor

To do this, DIP Switch [1] (INTERRUPT) must be set to ON (SW-DOWN). (See page 24.)

Press the PRINT button while printing or copying. The printer stops printing, captures the new image, and starts printing the new image.

In SMALL mode, the printer stops printing and captures the first image.

If the printout image is blurred

A rapidly moving image may be blurred when printed. Should this occur, change DIP Switch [4] (MEMORY) to FIELD (SW-UP). (See page 24.) The printout quality will be poorer, but less blurred.

To print in SMALL mode

You can print in SMALL mode, where two different images can be captured and printed together on one printout, by setting the image size selector on the front panel to the SML position.

To print in SMALL mode: Press the PRINT button twice in step 4. When you press the PRINT button once, the buzzer sounds and the first image is captured. The printer starts printing after the PRINT button is pressed twice.

For detailed information on SMALL mode, see "Selecting Printing Direction/Image Size" on the next page.

To feed the paper

Press and hold down the FEED button to feed the paper. **Do not pull out the paper manually.**

Storing printouts

- Avoid storing printouts in a location subject to the following. Storage of your printouts in such a place results in fading of printouts.
 - Store printouts in a cool and dark place (below 30°C or 86°F). We recommend storing printouts in a bag made of clay-free paper or polypropylene.
 - Do not store printouts in a hot or humid place. Do not leave printouts in direct sunlight or other bright places.
 - Do not allow any volatile organic solvent or vinyl chloride to touch printouts. Alcohol, plastic tape or film will cause the printout to fade.
- Do not stack your printouts on or under a diazo copy sheet. Also do not attach the printed surface to another printed surface. The printout may become discolored.
- To attach the printout to another piece of paper, use double-sided adhesive tape or water-based glue.



Making copies of the last printout

Press the COPY button. The printer makes a copy of the last printout. The image of the last printout is retained in the printer's memory until you press the PRINT button again or turn the power off.

To copy in different directions and sizes

You can copy the last printout in different directions and sizes except in SMALL mode. Before pressing the COPY button, select the printing direction and size as described in "Selecting the Printing Direction/Image Size" (See this page.)

Notes

- If you press the COPY button immediately after turning the power on, the alarm buzzer will sound as nothing is stored in memory.
- In the SMALL mode, if you press the COPY button after you have pressed the PRINT button only once, the alarm buzzer will sound and the printer will not copy.

To make multiple copies of the same printout

Press the COPY button as many times as necessary (maximum 11 copies including the first printout) while printing or copying the first printout. Each time you press the COPY button, a short buzzer sounds.

To interrupt copying

Press either the OPEN or FEED button.

Selecting the Printing Direction/Image Size

You can make variations of printouts using the STD/SIDE selector, image size selectors and the DIP switches.

Selecting the printing direction

You can select the printing direction using the STD/SIDE selector. **To print in the same direction as the one displayed in the video monitor, set the selector to STD (standard).** **To print the image in the direction where the image is rotated by 90 degrees counterclockwise, set the selector to SIDE.**



Image displayed on the video monitor

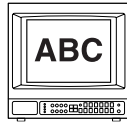

Printouts

When set to the STD position

When set to the SIDE position

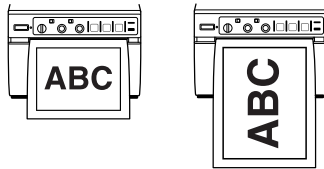

Selecting the image size

You can print in normal or small size by changing the image size selector. You can also obtain a printout of the image at the left or right, top or bottom of the video image on the monitor after it has been enlarged twice.

Variations of printouts

Printouts obtained by the combination of the STD/SIDE selector and image size selector

The table in the right column shows various printouts that can be obtained according to the combination of settings of the STD/SIDE selector and image size selectors.

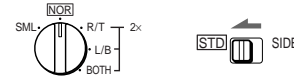

In addition to variations in the right column, the following printout variation is available.

Negative printouts

You can make negative printouts by setting the POSI/NEGA switch on the front panel to the NEGA position.

Image size selector position	Printing direction selector position	
	STD	SIDE
NOR (Normal)		
SML (Small)		
R/T (Right/Top)		
L/B (Left/Bottom)		
BOTH		



Operation



Operation

Adjusting the Contrast and Brightness

You can adjust the contrast and brightness of the printout.

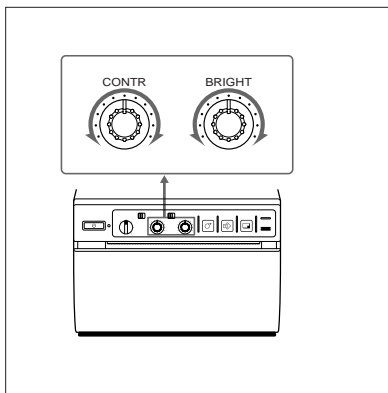

Note

To adjust the contrast and brightness while confirming the adjusted image on the video monitor, set DIP Switch [8] (OUTPUT) to EE (SW-UP).

After adjusting the contrast and brightness, be sure to reset DIP Switch [8] to THRU (SW-DOWN).

Since the video signal is directly input to the video monitor without being processed by the printer when the setting is THRU, you can monitor the video signal as it is input directly from the video equipment.

To adjust the contrast

You can adjust the contrast of image using the CONTR control.

To make the contrast stronger, turn the CONTR control clockwise.

To make the contrast weaker, turn the CONTR control counterclockwise.

To adjust the brightness

You can adjust the brightness of printouts using the BRIGHT control.

To make the image brighter, turn the BRIGHT control clockwise.

To make the image darker, turn the BRIGHT control counterclockwise.

Note

You cannot adjust the image once it has been captured in memory. Restore an image after adjustment by pressing the PRINT button.

Remotely Controlling the Printer

You can remotely control the printer using the RM-91 remote control unit or the foot switch connected to the REMOTE connector on the rear panel.

Since the button on the remote control unit or foot switch functions exactly same as the PRINT button, pressing either of them during printing or copying results in an image being captured and immediately printed when DIP Switch [1] (INTERRUPT) on the rear panel is set to ON (SW-DOWN). (See page 24.)

Precautions

On safety

- Check the operating voltage before operation. Operate the unit only with a power source specified in "Specifications".
- Stop operation immediately if any liquid or solid object falls into the cabinet. Unplug the unit and have it checked by qualified personnel.
- Unplug the unit from the wall outlet if you will not be using it for a long time. Disconnect the power cord by grasping the plug. Never pull the cord itself.
- Do not disassemble the cabinet. Refer servicing to qualified personnel only.
- Do not touch the cutting blade of the printer.
- Connect the power plug of the printer to a wall outlet with a protective earth terminal. The safety earth should be properly established.

On operation

Do not turn the power off while the printer is printing. The thermal head may be damaged.

On the printer carriage

Do not carry or move the printer when the paper roll is placed in the printer. Doing so may cause a malfunction.

On installation

- Place the printer on a level and stable surface. If you use the printer with placed on an uneven surface, malfunction of the printer is likely to occur.
- Do not install the printer near heat sources. Avoid locations near radiators or air ducts, or places subject to direct sunlight or excessive dust, humidity, mechanical shock or vibration.
- Provide adequate air circulation to prevent heat build-up. Do not place the printer on surfaces such as rugs, blankets, etc., or near materials such as curtains and draperies.
- If the printer is subjected to wide and sudden changes in temperature, such as when it is moved from a cold room to a warm room or when it is left in a room with a heater that tends to produce large amounts of moisture, condensation may form inside the printer. In such cases the printer will probably not work properly, and may even develop a fault if you persist in using it. If moisture or condensation forms, turn off the power and allow the printer to stand for at least one hour.

Maintenance

Cleaning the cabinet

Do not use strong solvents to clean the printer. Thinner or abrasive cleansers will damage the cabinet.

Cleaning the thermal head

If the printout is dirty or white stripes appear on the printouts, clean the thermal head using the cleaning sheet supplied.

1 Press the power switch to turn on the printer.

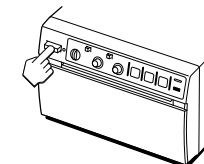

2 Press the OPEN button to open the door.

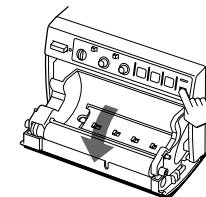

3 Insert the cleaning sheet, with the black surface facing down, into the groove in paper tray.

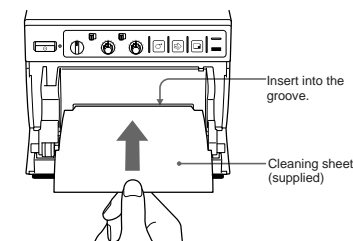

Continue to next page →

4 Close the door by pushing it.**5 Press the FEED button and keep it pressed.**

When the buzzer sounds and the printer start ejecting the cleaning sheet, release the FEED button.

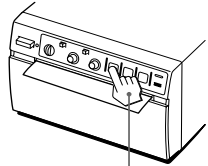

Keep pressing the FEED button.

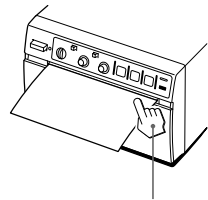

When the buzzer sounds and the printer starts ejecting the cleaning sheet, release the button.

Cleaning is completed.

6 Press the OPEN button to open the door and remove the cleaning sheet.**7 Close the door by pushing it.****Notes**

- Do not press the PRINT or COPY button while the cleaning sheet is in the printer.
- Clean the head only when necessary. If you clean the head too often, it may cause a malfunction.

Specifications

Power requirements and consumption

100 to 120 V AC, 50/60 Hz, 1.5 A
220 to 240 V AC, 50/60 Hz, 0.8 A

Operating temperature

5°C to 35°C (41°F to 95°F)

Operating humidity

20 % to 80 % (no condensation allowed)

Dimensions Approx. 154 × 105 × 260 mm (w/h/d)
(6 1/8 × 4 1/4 × 10 1/4 inches)

Mass Approx. 3.4 kg (7 lb 8 oz), Main unit only

Thermal head Thin-film thermal head (with built-in drive IC) 1280-dot drive

Gradation 256

Resolution (in WIDE 1 mode)

EIA: 1210 × 490 dots
CCIR: 1210 × 582 dots

Print size (in NOR and WIDE 1 mode)

STD mode
EIA: 94 × 72 mm
CCIR: 94 × 71 mm

SIDE mode

EIA: 126 × 96 mm
CCIR: 126 × 95 mm

Printing speed (in STD and NOR mode)

About 3.9 seconds/screen (at factory settings)

Picture memory

800 K × 8 bits for one frame

Input/output connectors**VIDEO IN (BNC)**

EIA or CCIR Composite video signals
1.0 Vp-p, 75 ohms/high-impedance
(EIA/CCIR automatically discriminated)

VIDEO OUT (BNC)

EIA or CCIR Composite video signals
1.0 Vp-p, 75 ohms, loop-through/EE switchable

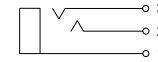
REMOTE (stereo minijack)

1 GND

2 PRINT SIGNAL (TTL)

Input of LOW pulse over 100 msec. initiates print.

3 PRINT BUSY (TTL)

Goes HIGH during printing.

Supplied accessories

Paper roll (UPP-110HG) (1)
BNC ↔ BNC connecting cable (1)
AC power cord (1)
Head cleaning sheet (1)
Media label (1)

The following specifications are applied only to the UP-895MD/895CE models:**Storage and transport temperature**

-20°C to 60°C (-4°F to 140°F)

Storage and transport humidity

20 % to 80 % (no condensation allowed)

Protection against electric shock

Class 1

Protection against harmful ingress of water

Ordinary

Degree of safety in the presence of flammable anesthetics or oxygen

Not suitable for use in the presence of flammable anesthetics or oxygen

Mode of operation

Continuous

Design and specifications are subject to change without notice.



Others



Others

Troubleshooting

The following troubleshooting checks will help you correct the most common problems you may encounter with your printer. Before proceeding with these trouble check, first checks that the power cord is firmly connected. Should the problem persist, unplug the printer and contact your Sony dealer or local authorized Sony service facility.

Symptom	Cause/remedy
White specks on the first few printouts.	When printing with a newly inserted roll of paper, dust on the surface of the paper may cause white specks on the printouts. → Feed the paper by pressing the FEED button until clean paper appears. (page 26)
Printing does not start when you press the PRINT button.	<ul style="list-style-type: none"> Paper does not feed. <ul style="list-style-type: none"> → Is the paper slack? → Is the power turned on? → Are all connections correct? → Did you press the PRINT button twice in SMALL mode? (page 27) When the alarm buzzer sounds: <ul style="list-style-type: none"> → Has the thermal head overheated? The thermal head may overheat when the printer prints dark image continuously. In such a case, the EMPTY lamp blinks. Wait until the head cools down. → Is the video signal of the image input? → Is the paper loaded correctly? Paper feeds, but printing does not start. <ul style="list-style-type: none"> → Is the paper loaded with the thermo-sensitive side up? (page 26)
Black borders or missing portions around the printout.	This problem may result from the video signal input to the printer. → Change the setting of the DIP switches [6] and [7] (SCAN). (page 24)
Paper jam	<ul style="list-style-type: none"> Open the door by pressing the OPEN button, then pull the jammed paper slowly and remove it. There is condensation inside the unit. <ul style="list-style-type: none"> → Moving the unit suddenly from a cold place to a warm place often results in condensation forming. In the event of condensation forming, remove the paper, turn off the power and allow the unit to stand for about one to two hours.
The printout is dirty.	The thermal head is dirty. → Clean the thermal head with the head cleaning sheet supplied with the unit. (page 31)

Symptom	Cause/remedy
The printer stops printing when it continuously prints dark images. (The alarm buzzer sounds.)	This is likely to occur when the printer prints continuously 15 or more dark images. In such a case, the buzzer sounds. This is because a protective circuit guards against heat build-up in the thermal head. Stop printing for a while.
White lines or small letters on the screen are not printed clearly.	Is DIP Switch [1] (INPUT) set to B & W when the input signal is a black and white signal? (page 25)
Small squares appear over the whole screen.	Is DIP Switch [1] (INPUT) set to COLOR when the input signal is a color signal? (page 25)
The printout is too dark or too light.	<ul style="list-style-type: none"> Is the DIP switch [2] (75Ω) set correctly? (page 25) Is the PAPER TYPE switch in the paper tray set correctly? (page 23) Is the GAMMA switch in the paper tray set correctly? (page 23)
The printout seems stretched or enlarged.	The DIP switch [3] (ASPECT) is set to 1:1. → Set it to 4:3. (page 24)

Location and Function of Parts

For details, refer to the pages indicated in parentheses.

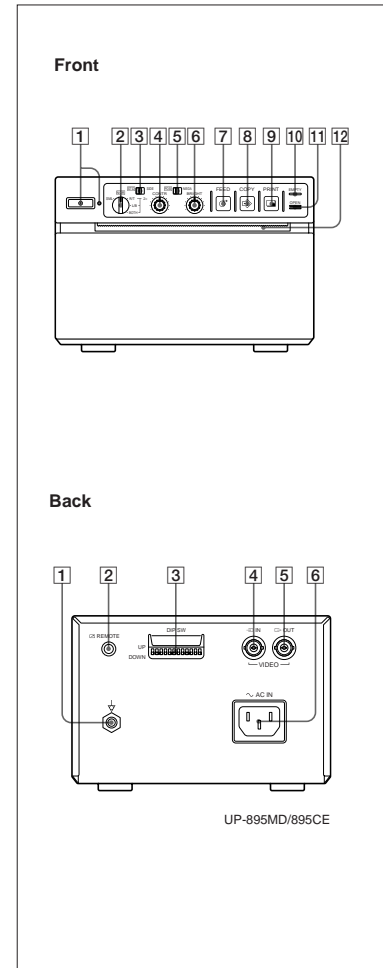

Front

- 1 Power switch and lamp**
Turns the power on. The power lamp is lit while the power is on.
- 2 Image size selector (29)**
Selects the size of the image to be printed.
- 3 STD (standard)/SIDE selector (28, 29)**
Selects the printing direction.
- 4 CONTR (contrast) control (30)**
Adjusts the contrast of the printouts.
- 5 BRIGHT (brightness) control (30)**
Adjusts the brightness of the printouts.
- 6 POSI(positive)/NEGA (negative) selector (29)**
Set this to the NEGA position to make negative printouts.
- 7 FEED button (26, 27, 28, 32)**
Press to feed paper. The paper feeds as long as the FEED button is held down. Pressing this button during printing results in an interruption of the printing.
- 8 COPY button (28)**
Prints another copy of the previous printout.
- 9 PRINT button (27)**
Prints the image currently displayed on the video monitor. The image displayed when you press the PRINT button is stored in memory.
- 10 EMPTY lamp (27)**
Lights when the printer is out of paper.

Continue to next page →

Location and Function of Parts

11 OPEN button (26, 31)

Opens or closes the door. Also, interrupts printing midway.

When the door is open, you can see the slide switches in the paper tray.

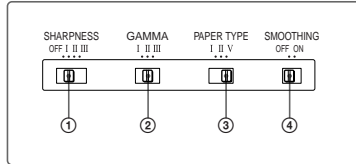

- ① **SHARPNESS switch**
Adjusts the sharpness of the printout.
- ② **GAMMA switch**
Sets the tone of the printouts (density gradation).
- ③ **PAPER TYPE switch**
Selects the paper type.
- ④ **SMOOTHING switch**
Selects the line density.

For detailed information on slide switches, see "Setting the Slide Switches on the Paper Tray" on page 22.

12 Paper feeder and cutter

Cuts the printing paper.

Back

- ① **⚡ Equipotential terminal (only for UP-895MD/895CE)**
Used to connect to the equipotential plug to bring the various parts of a system to the same potential. Refer to "Important safeguards/notice for use in the medical environments" on page 20.
- ② **☑ REMOTE connector (22, 30)**
Connect the RM-91 remote commander or the foot switch for controlling print operation from a distance.
- ③ **DIP SW (switches) (23)**
Sets the print modes and functions.
- ④ **📡 VIDEO IN (input) connector (BNC type) (22)**
Connect to the video output connector of the video equipment.
- ⑤ **📡 VIDEO OUT (output) connector (BNC type) (22)**
Connect to the video input connector of the video monitor. The output signal type depends on DIP switch ⑧ (OUTPUT).
- ⑥ **~AC IN (AC power input) connector (22)**
Connect to a wall outlet using the AC power cord supplied with the unit.



Others

Section 2

Service Information

2-1. Board Layout

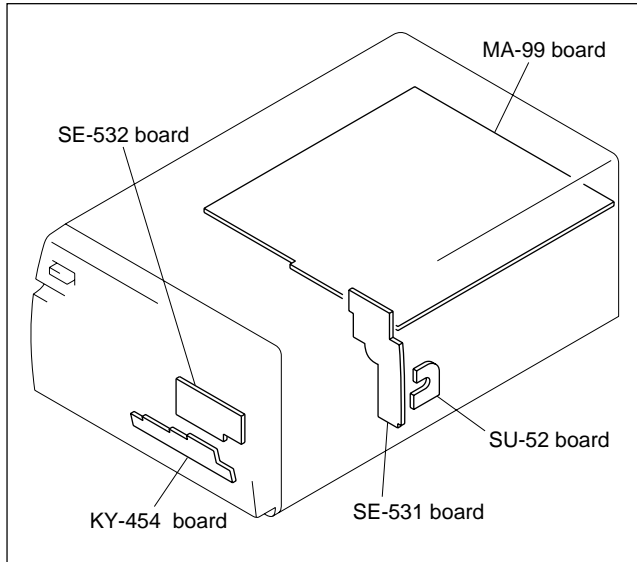

2-2. Disassembly

Note

Remove the top cover in the order shown in the figure during removal.

Removal of Top Cover

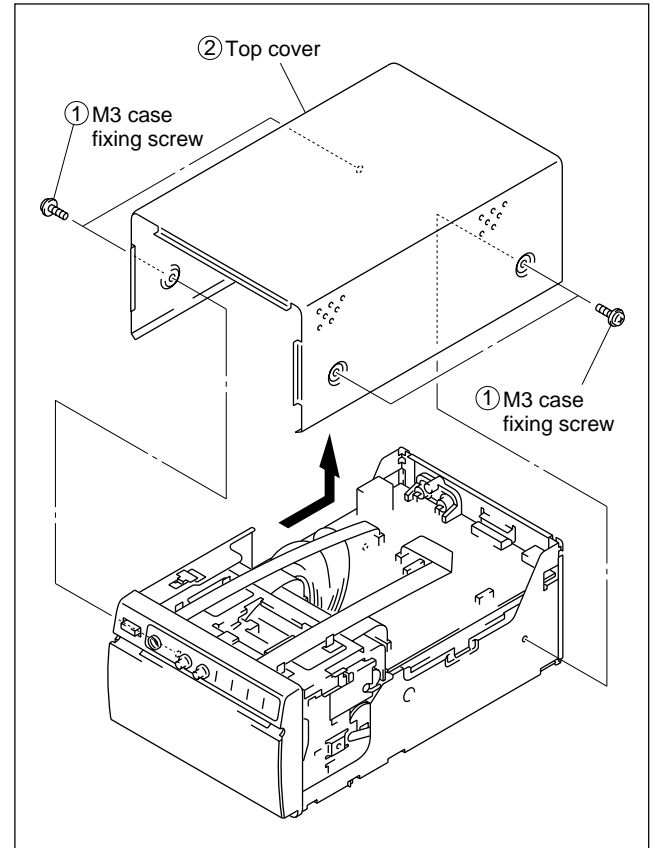

2-3. Removal of Major Parts

2-3-1. Removal of Mechanical Block

1. Remove the top cover. (Refer to Section 2-2.)

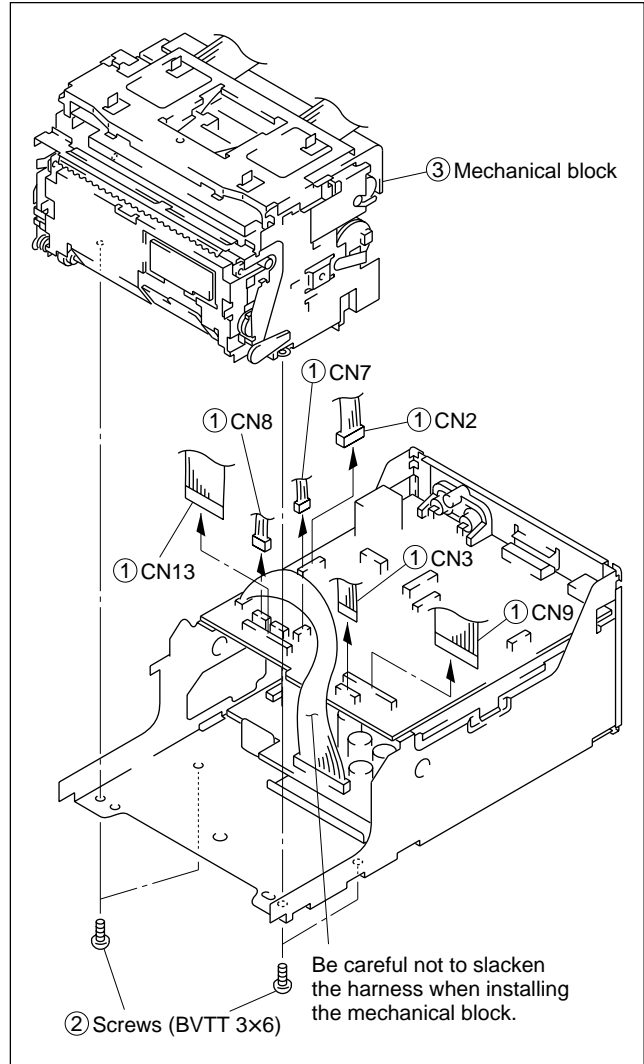
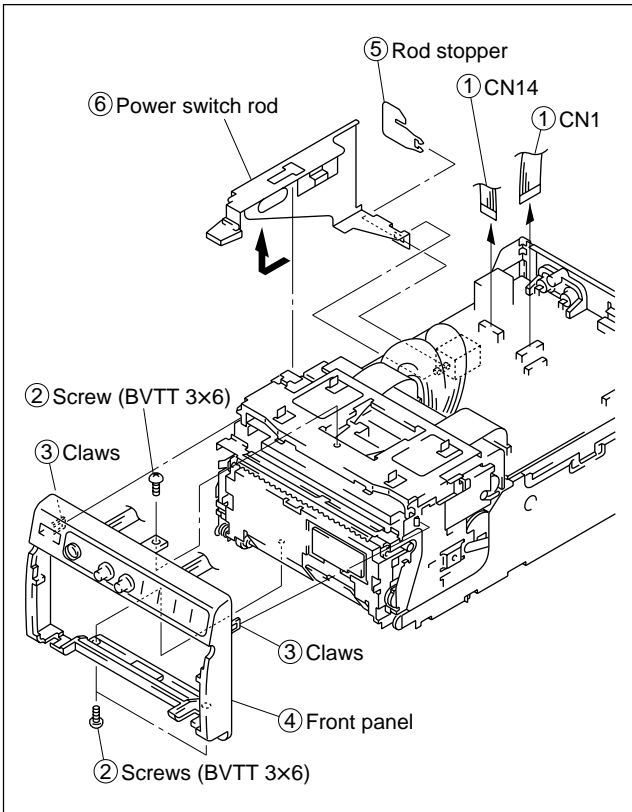
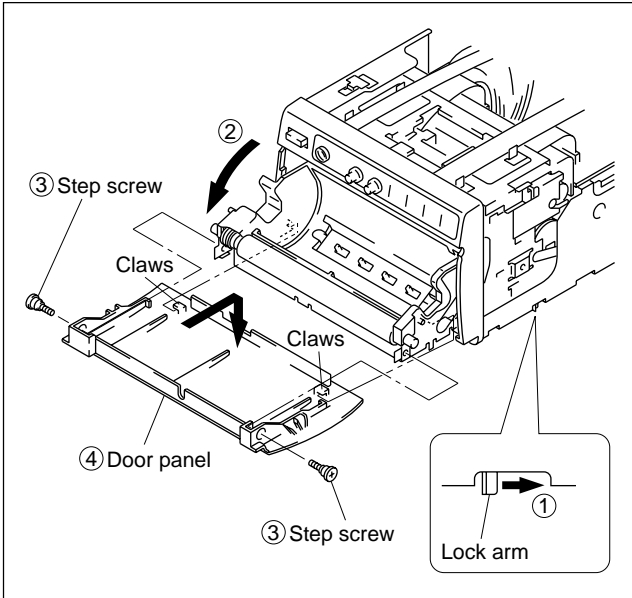

2-3-2. Removal of MA-99 Board

1. Remove the top cover. (Refer to Section 2-2.)

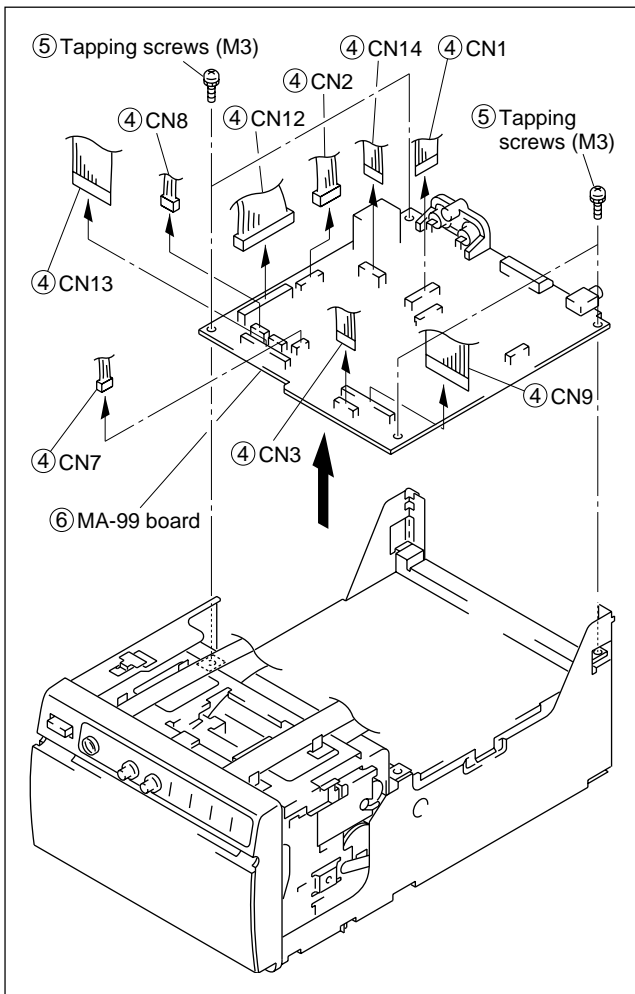
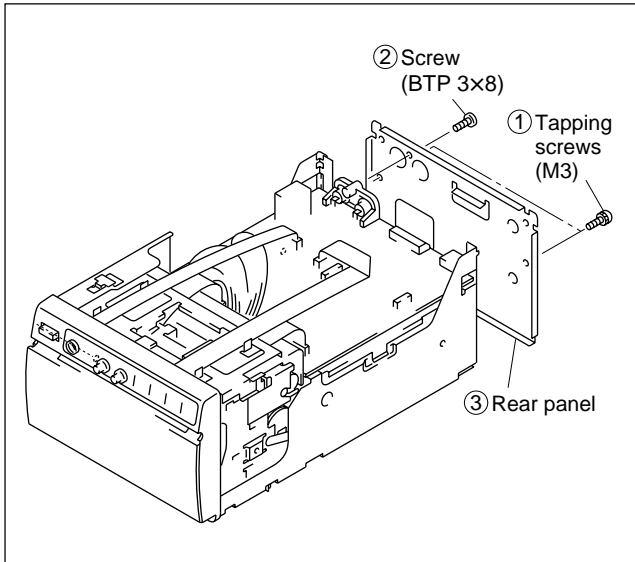

2-3-3. Removal of Switching Regulator

1. Remove the top cover. (Refer to Section 2-2.)
2. Remove the front panel, door panel and power switch rod. (Refer to Section 2-3-1.)
3. Remove the MA-99 board. (Refer to Section 2-3-2.)

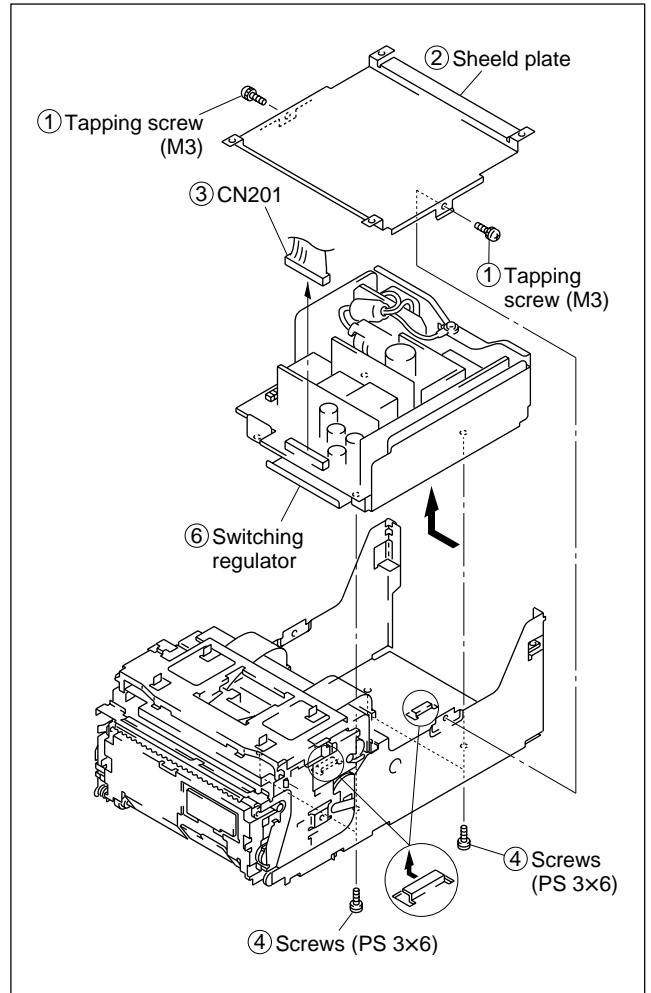

2-3-4. Removal of Thermal Head

1. Remove the top cover. (Refer to Section 2-2.)
2. Remove the front panel and power switch rod. (Refer to Section 2-3-1.)

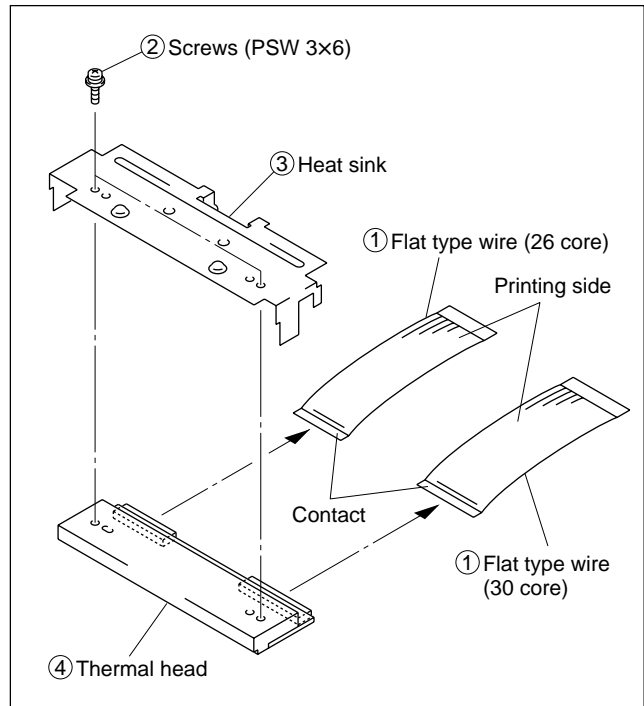
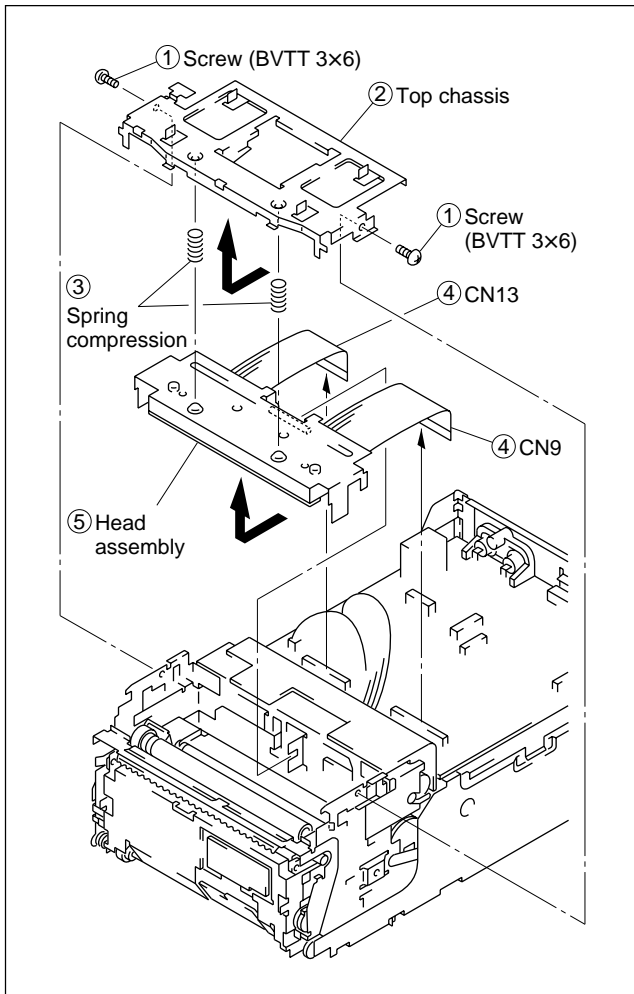

2-4. Tightening the Screws

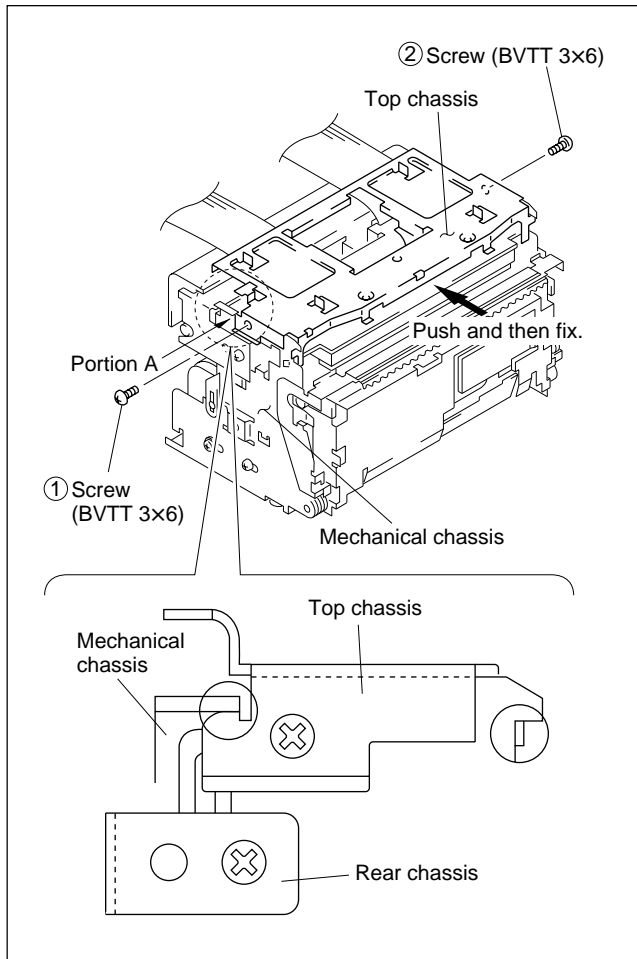

Note

Confirm that no clearance exists between the mechanical chassis and top chassis.

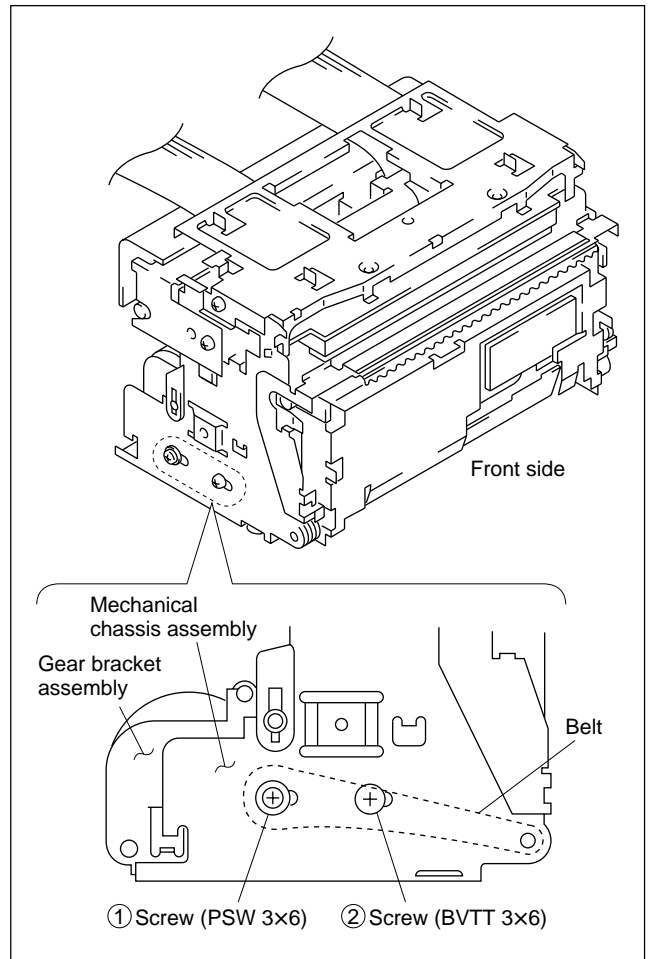

Notes

1. Be careful not to hold the gear bracket by hand when installing screws ① and ②.
2. Confirm that the belt tension is not loosened after screw installation.

2-5. Installation of Fan Motor

Note

Install the fan motor while paying the attention to the direction of the harness with the surface, to which the fan motor sticker is attached, down.

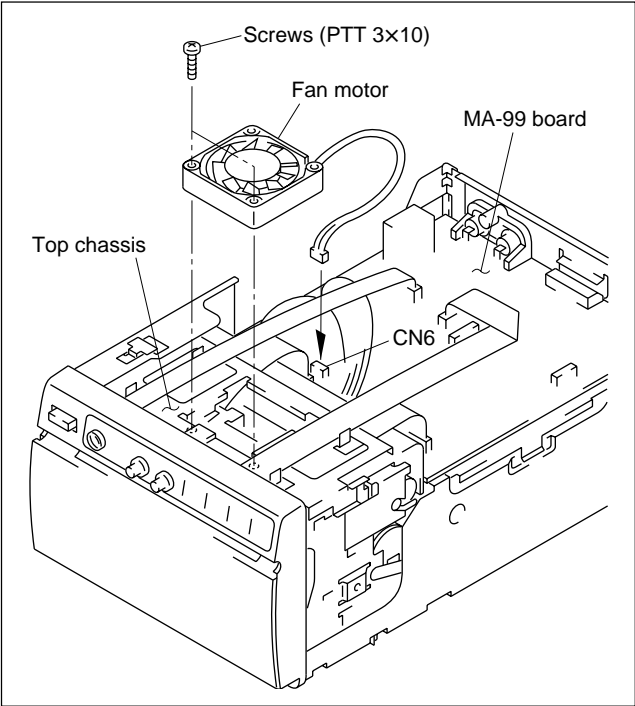

Section 3

Electrical Alignment

[Equipment Required]

- Oscilloscope
- Digital voltmeter
- 10 steps signal generator
Tektronix 1410 or equivalents (For NTSC signal)
Tektronix 1411 or equivalents (For PAL signal)

3-1. AGC Adjustment

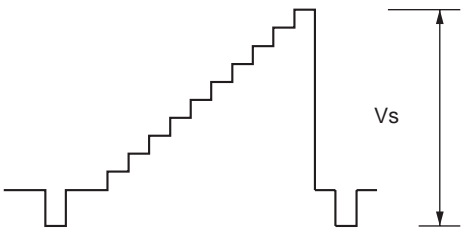
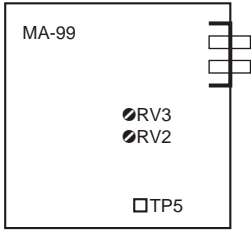
Machine condition for adjustment	Specification	Adjustments
<ul style="list-style-type: none"> • Input signal: 10 steps signal • No monitor is connected. • Set rear panel DIP switch ⑨ to up. (AGC-ON) <p>Procedure</p> <ol style="list-style-type: none"> 1. Input a 10 steps signal and set DIP switch ⑫ to DOWN. Adjust RV3 (AGC REF) so that V_s is 700 mV. 2. Set DIP switch ⑫ to UP and adjust RV2 (AGC GAIN) so that V_s is 630 mV. 	<p>TP5 (AMP IN)/MA-99 (C-3) Output waveform</p>  <ul style="list-style-type: none"> • Adjust so that V_s is 700 mV when AGC is ON and 75 Ω terminator is on. • Adjust so that V_s is 630 mV when AGC is ON and 75 Ω terminator is off. 	<p>AGC REF adjustment ●RV3/MA-99 (C-2) AGC GAIN adjustment ●RV2/MA-99 (C-2)</p> 

3-2. Video Level Adjustment

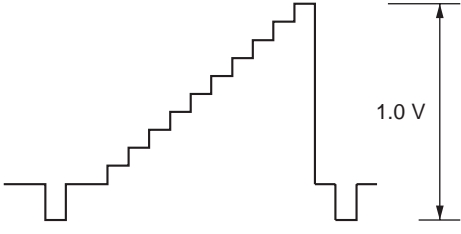
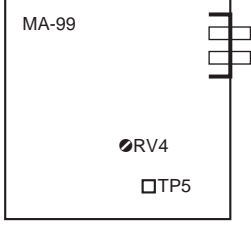
Machine condition for adjustment	Specification	Adjustments
<ul style="list-style-type: none"> • Input signal: 10 steps signal • In case, monitor is not connected, set DIP switch ⑫ on the rear panel to ON, if connected, set to OFF. • Adjust RV4 (AGC OFF CONT) using 10 steps signal input. 	<p>TP5 (AMP IN)/MA-99 (C-3) Output waveform</p>  <p>Adjust so that video signal level is 1.0 V.</p>	<p>AGC OFF CONT adjustment ●RV4/MA-99 (C-2)</p> 

3-3. Brightness and Contrast Adjustment

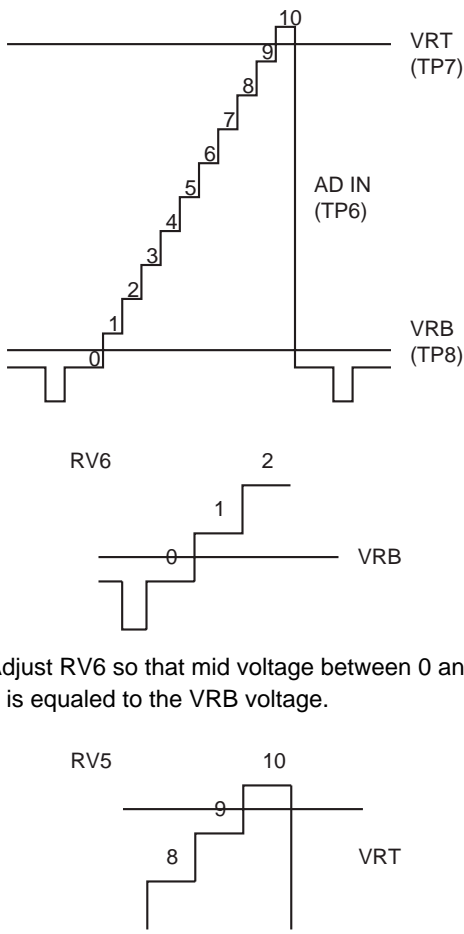
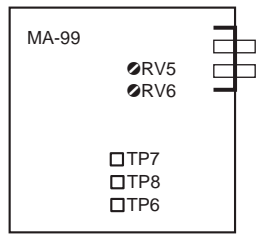
Machine condition for adjustment	Specification	Adjustments
<ul style="list-style-type: none"> • Input signal: 10 steps signal • In case, monitor is not connected, set DIP switch ⑫ on the rear panel to ON, if connected, set to OFF. • Set CONTRAST and BRIGHT knobs to the center position on the front panel. 	<p>TP6 (AD IN)/MA-99 (B-3) Output waveform TP7 (VRT)/MA-99 (B-3) Output voltage TP8 (VRB)/MA-99 (B-3) Output voltage</p>  <p>Adjust RV6 so that mid voltage between 0 and 1 is equaled to the VRB voltage.</p> <p>Adjust RV5 so that mid voltage between 9 and 10 is equaled to the VRT voltage.</p>	<p>C ADJ adjustment ●RV5/MA-99 (C-1) B ADJ adjustment ●RV6/MA-99 (C-1)</p> 

3-4. Head Voltage Adjustment

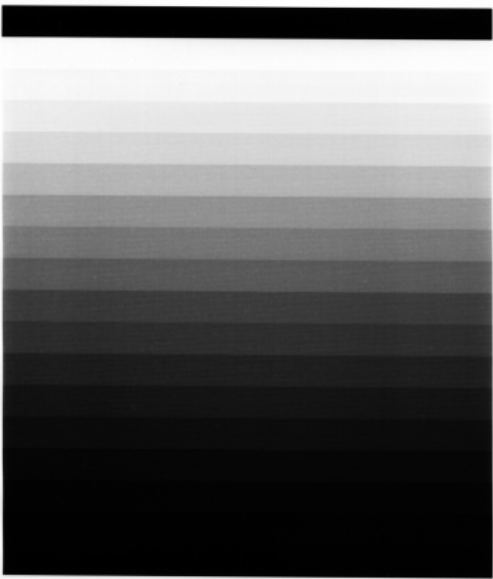
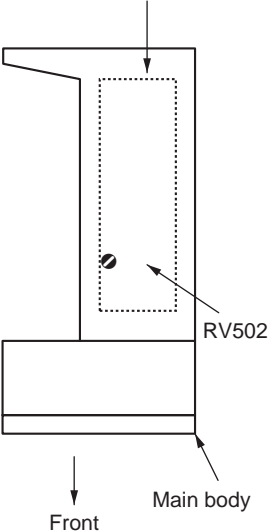
Machine condition for adjustment	Specification	Adjustments
<ul style="list-style-type: none"> • Input signal: nothing • Set all DIP switches on the rear panel to DOWN. • Set each switch on the front panel to NORM, STD, and POSI, respectively. • Set the POWER switch to ON while pressing the PRINT and COPY buttons. • Press the PRINT button to print a stair step pattern. 	 <p style="text-align: center;">Stair step</p> <p>Adjust RV502 so that a smooth gradation is obtained in 17 steps.</p>	<p>RV502/ Switching regulator</p> <p>Switching Regulator (on the right side panel)</p>  <p style="text-align: center;">Front</p> <p style="text-align: right;">Main body</p>

3-5. Initialization of Print Count History

Machine condition for adjustment	Specification	Adjustments
<ul style="list-style-type: none"> • Set the POWER switch to ON while pressing the PRINT, COPY, and FEED buttons. 	<p>Release the buttons when the buzzer sounds three times. The initialization of print count history is then completed (becomes zero in sheet count).</p>	<p>Nothing</p>

Section 4

Circuit Operation Description

Outline

The electrical circuit of UP-895 mainly consists of the following blocks.

* Video circuit

The input video signal is amplified using a video amplifier circuit to perform brightness, contrast, trap filter, and AGC processing.

* A/D and D/A converters

The analog signal output from a video circuit is converted from analog to digital. The A/D-converted data is converted from digital to analog to output it to the outside.

* Memory and head control G/A

Print data is fetched to frame memory (DRAM). Image data on the memory is also PWM-converted for image processing and sent to the thermal head.

* CLK generator

This block generates the operation clock of memory and head control G/A.

* Frame memory (SDRAM)

This block memorizes print data.

* Motor drive

Each motor of a head, platen, and fan is driven according to the command from system control CPU.

* Sensor circuit

This block detects the sensor values of a head, paper, cutter, door, and head temperature.

* System control CPU

This block supervises and controls each block.

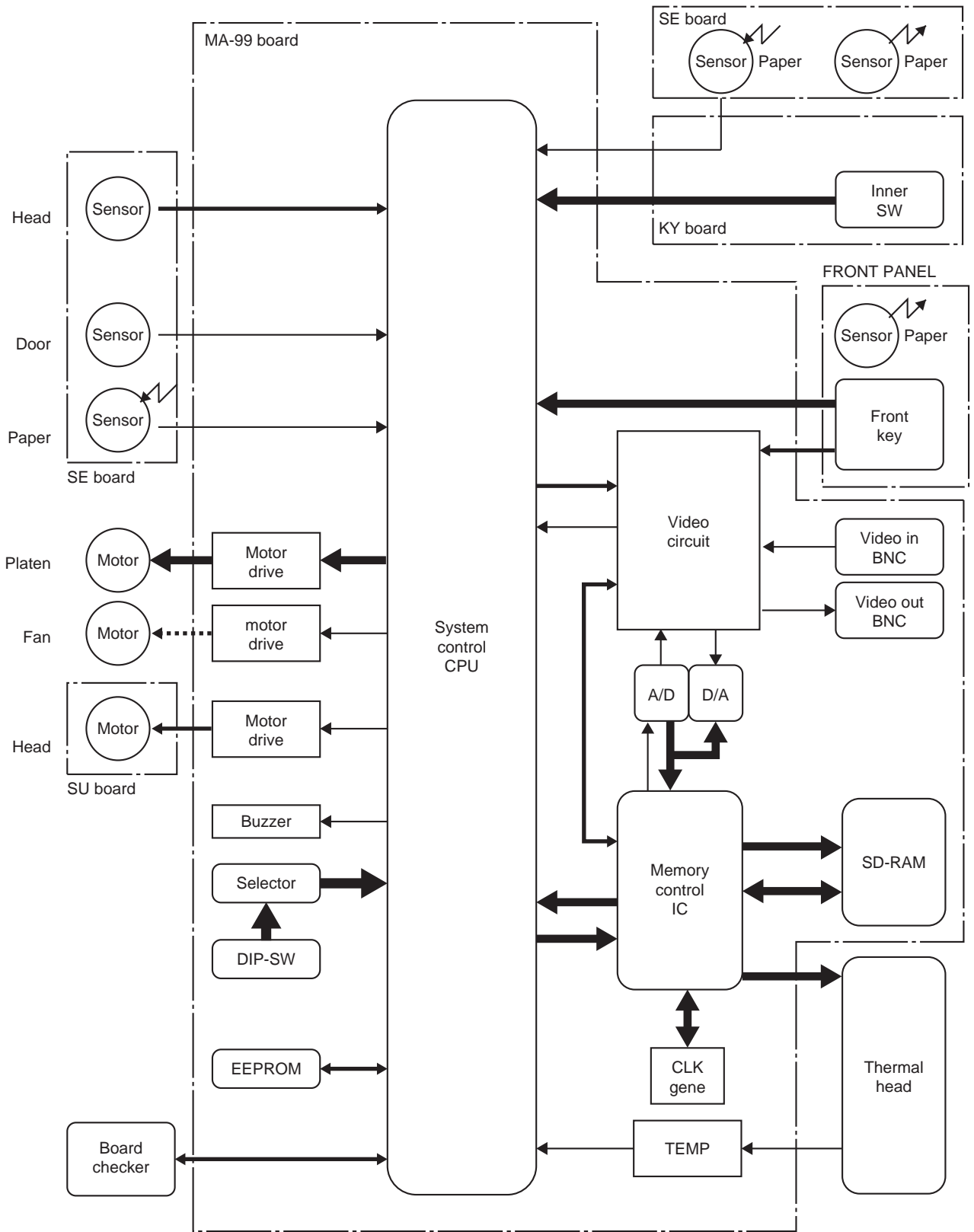

Electrical Block Diagram of UP-895

4-1. Video Circuit

4-1-1. BNC Input Connector - Trap Filter Circuit

A composite video signal is input from the BNC connector (VIDEO IN) to the MA-99 board. 75 Ω termination is turned on and off using a DIP switch. After that, the input signal branches into three paths. One is passed through a trap filter (FL1) for NTSC, and another is passed through a trap filter (FL2) for PAL. The other is not processed at all. These signals are input to analog selector 1 (IC1). Each signal is selected by a system control and input to video amplifier 1 (IC2).

4-1-2. nC-SYNC Generator Circuit

A nC-SYNC signal is generated from the SYNCOUT signal that is output from video amplifier 1 (IC2). The nC-SYNC signal is also used in an AGC circuit.

4-1-3. AGC Circuit

The signal from an analog selector 1 (IC1) branches into two paths. One is input to video amplifier 1 (IC2), and the other is input to the AGC circuit for detecting the peak of a signal. The gain is controlled by a contrast amplifier in video amplifier 1 (IC2). When an AGC function is set to ON, the peak voltage of the input video signal obtained by the AGC circuit is controlled by a system control (IC304) so that it is output from analog selector 2 (IC5). When it is set to OFF, the reference voltage is controlled by a system control (IC304) so that it is output from analog selector 2 (IC5). The gain is controlled by inputting the voltage to video amplifier 1 (IC2).

4-1-4. Brightness and Contrast Control

The video signal output from video amplifier 1 (IC2) is input through a buffer (Q220) to video amplifier 2 (IC6). For contrast control, the gain is controlled by inputting the voltage obtained using the volume on the front panel to video amplifier 2 (IC6).

The video signal output from video amplifier 2 (IC6) is input through a low-pass filter to the brightness control amplifier (Q7). For brightness control, the gain is controlled by inputting the voltage obtained using the volume on the front panel to the brightness control amplifier (Q7).

4-1-5. A/D Conversion and D/A Conversion

The video signal output from video amplifier 2 (IC6) is converted into a digital signal using an A/D converter and stored in memory by a memory and head control circuit.

The A/D-converted signal is converted into a video again using a D/A converter, and a sync signal is added using analog selector 3 (EE signal). Moreover, the sync signal is sent to analog selector 4 and output from the BNC connector (VIDEO OUT) to the outside. A relay (RY1) is used to switch THRUE and EE signals and controlled by a system control.

4-2. Clock Generator Circuit

A clock is generated by attaching a 23 MHz external oscillator (X500) to the clock generator circuit (IC505). This clock is phase-adjusted at the falling edge of an H sync pulse (nINTOUT2) when fetching a video signal. The noise contained in the clock signal generated at that time is eliminated by the internal circuit of a memory and head control circuit (IC501) and a delay circuit (IC504). By using the clock signal as a main clock, memory control is performed during image fetching.

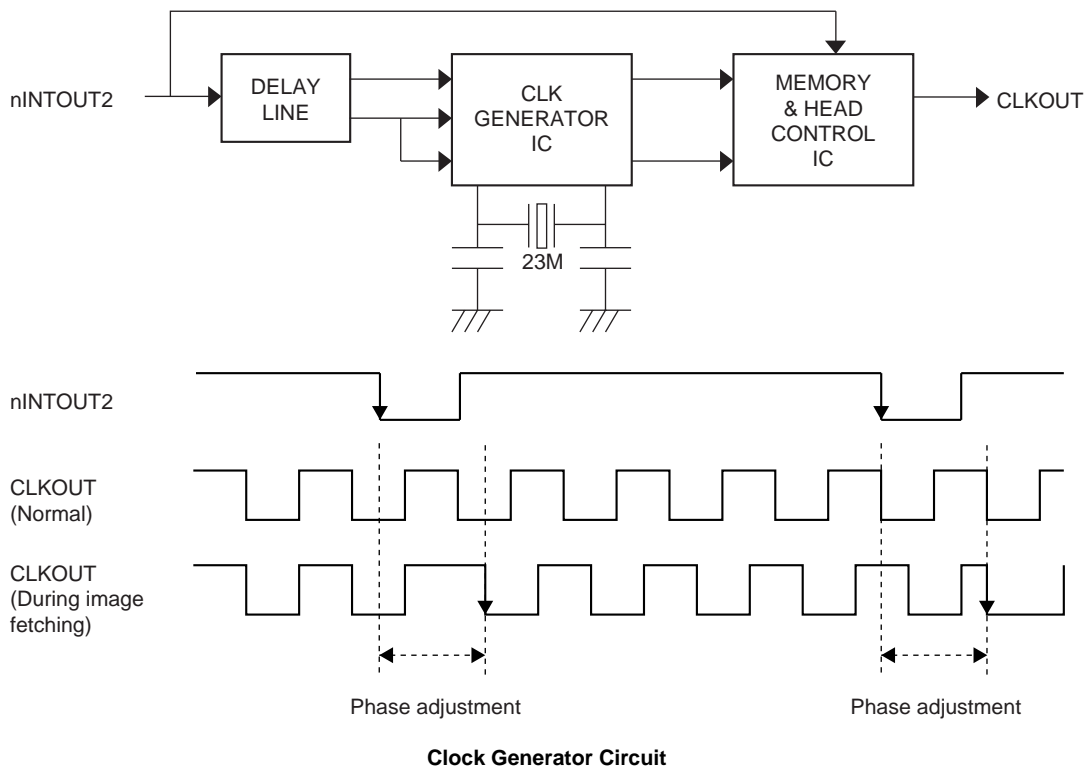

4-3. Memory and Head Control Circuit

The memory and head control circuit (IC501) consists of the following blocks. The operation in each block is determined by the serial data from a system control (IC304).

- (1) Register for storing the serial data from system control (IC304)
- (2) Frame memory write and read control
- (3) Thermal head control
- (4) Sync signal processing circuit
- (5) Line memory (for calculation and print)
- (6) Sharpness calculation circuit
- (7) Thermal storage correction calculation circuit
- (8) Count correction calculation circuit
- (9) Image scaling calculation circuit

4-3-1. Reading the Serial Data from System Control

There are eight types of data that a system control (IC304) sends to IC501. Registers for storing each data exist respectively. The type of a register in which data is stored is selected by combination of “high” and “low” levels of signals that are input to pins 11, 13, and 14 of IC501.

IC501-11pin	IC501-13pin	IC501-14pin	Register to be selected
L	L	L	Gamma data
L	L	H	Gamma data
L	H	L	Specifies the memory and print ranges.
L	H	H	Emphasizes the edge and sets the memory and print modes.
H	L	L	Count correction data
H	L	H	Sync signal processing parameter
H	H	L	Thermal history correction and other mode setting
H	H	H	Test pattern step width setting

4-3-2. Writing in Frame Memory

The next image data of one frame is written in the frame memory (IC503) when a fetch pulse is input from a system control (IC304) to pin 1 of IC501. The UP-895 uses a 64M-SDRAM (one word is 8 bits) as image memory. The sampling frequency is 23 MHz, and the memory space is 4096 × 2048.

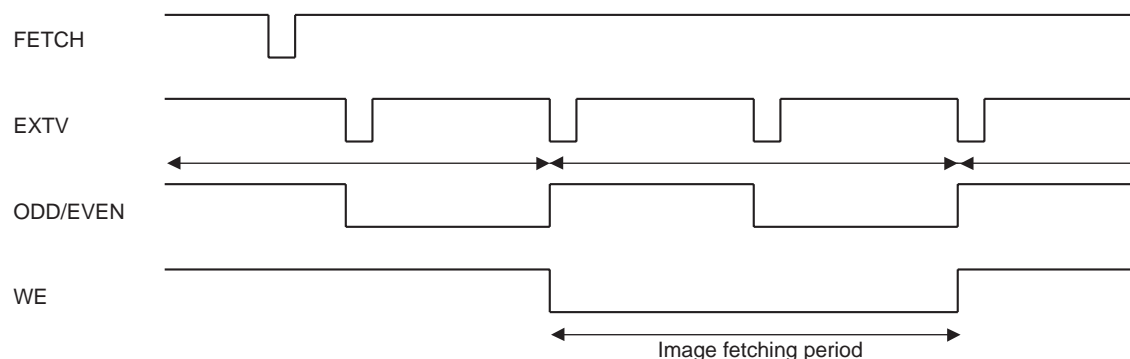

4-3-3. Transfer from Frame Memory to Line Memory

IC501 sets a COPYING signal to “L” so as to enter the print operation when a COPY pulse is input from a system control (IC304) to pin 2 of IC501. To perform printing, the one-line data selected from frame memory must be transferred to the head line memory in IC501. Data is transferred when a LINEPULS is input to pin 15 of IC501. IC501 reads necessary print data from the frame memory in the order corresponding to the print range and print direction specified by the mode setting from a system control. Next, IC501 stores the print data in the head line memory after edge emphasizing, thermal history correction, and interpolation.

4-3-4. Thermal Head Control and One-Line Memory

All thermal head controls are performed by IC501. Built-in head line memory is used when transferring print data to the thermal head. For more details, refer to Section 4-5. Thermal Head Section.

Block diagram of IC501

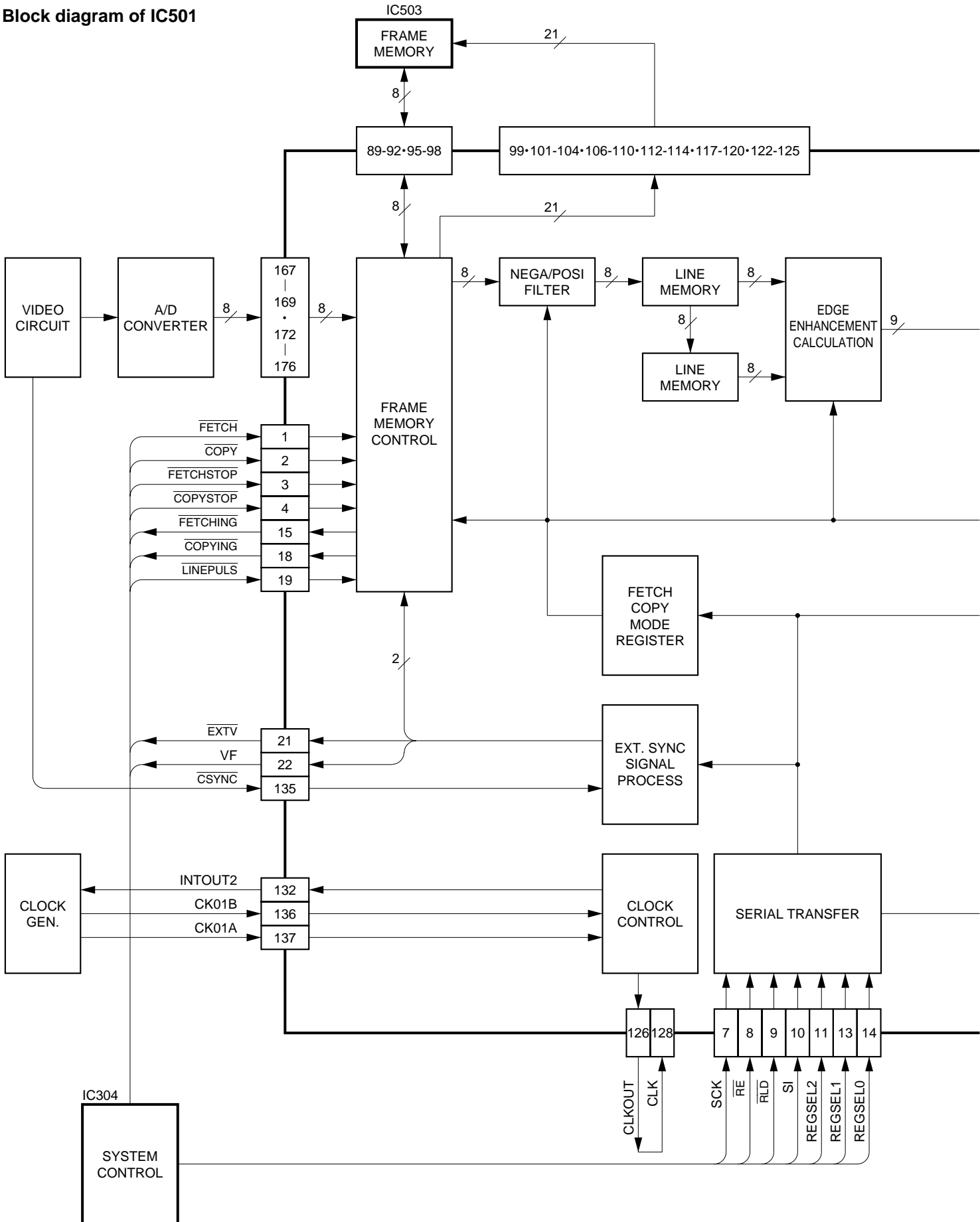

IC501

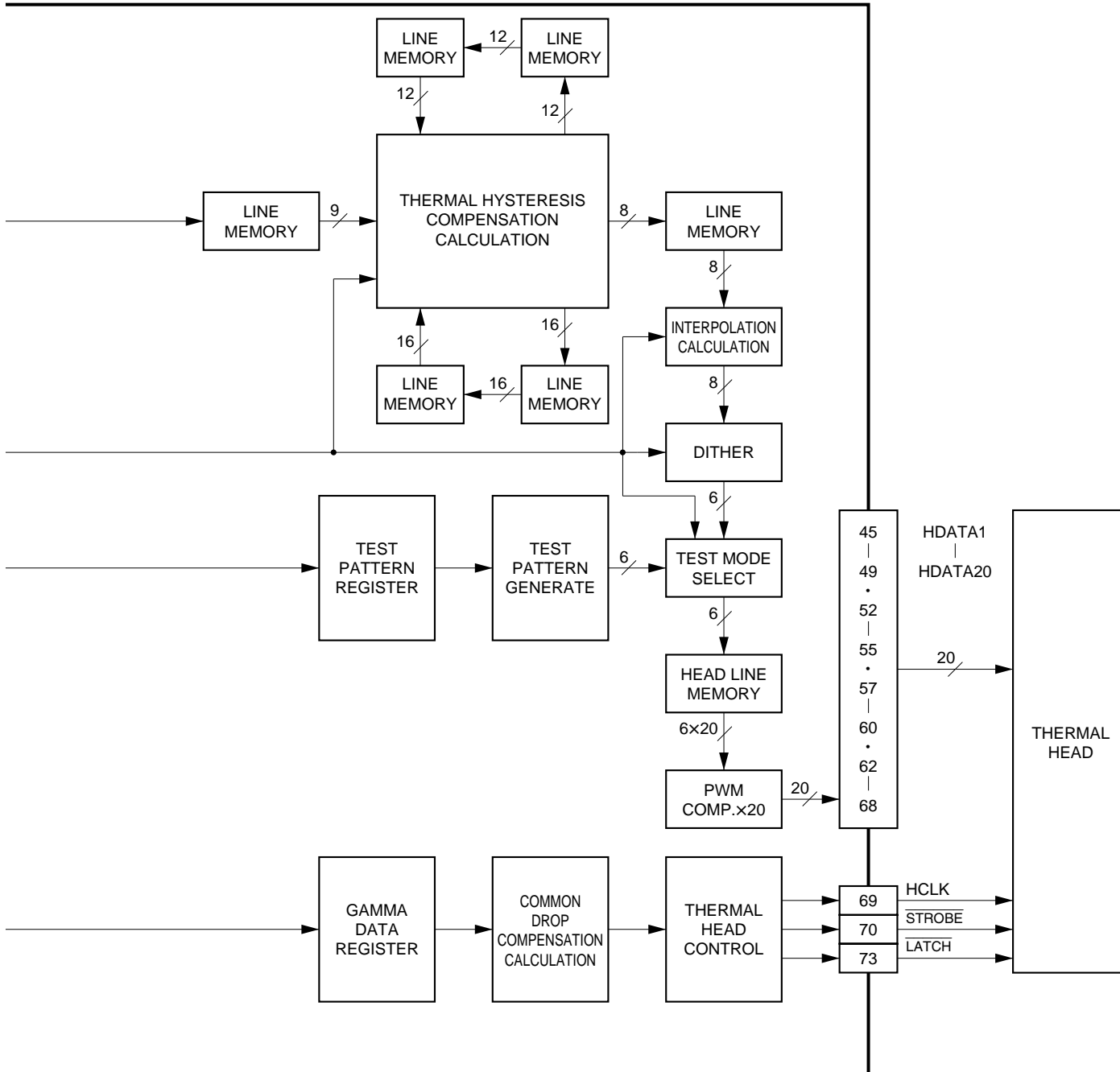

4-4. System Control Section

The system control section mainly consists of a microcomputer (IC304) and performs the following processing.

4-4-1. Reading of Keys

IC304 monitors the PRINT, OPEN/CLOSE, COPY, FEED, and REMOTE keys on the door panel. Each key is activated when the falling edge of a signal is detected.

IC304	Signal name
73pin	nDOOR_KEY
74pin	nPRINT_KEY
75pin	nCOPY_KEY
76pin	nFEED_KEY

4-4-2. Reading of Function Switches

IC304 monitors the setting of a front slide switch, inner slide switches, and a rear DIP switch and reflects its setting on the operation.

Front slide switch (on the front panel)

IC304	Function	Operation
80pin	POSI/NEGA	L: NEGA H: POSI
1pin	STANDERD/SIDE	L: STANDARD H: SIDE
79pin	PRINT SIZE	0.00 V: SMALL 1.25 V: NORMAL 2.50 V: ZOOM1 3.75 V: ZOOM2 5.00 V: ZOOM1&2

Inner slide switches (S1 through S4)

IC304	Function	Operation
5pin	SMOOTH	L: NORMAL H: HIGH
2pin	SHARPNESS	0.00 V: NORMAL 2.50 V: SOFT 5.00 V: HARD
4pin	PAPER TYPE	0.00 V: TYPE I 1.67 V: TYPE II 3.33 V: TYPE III 5.00 V: TYPE IV
3pin	GAMMA	0.00 V: TONE I 2.50 V: TONE II 5.00 V: TONE III

Rear DIP switch (S300)

IC304-66, 69pin SWSEL[3-0]	Function	IC304-66, 69pin:SWDATA	
		L (Default)	H
0	①INTERRUPT	ON	OFF
1	②POST FEED	ON	OFF
2	③ASPECT	4:3	1:1
3	④MEMORY	FRAME	FIELD
4	⑤DIRECTION	NORMAL	REVERS
5	⑥SCAN1	WIDE1	WIDE 2
6	⑦SCAN2	–	NORMAL
7	⑧THRUE/EE	THRUE	EE
8	⑨AGC	OFF	ON
9	⑩RESERVED	–	–
10	⑪INPUT	B&W	COLOR

4-4-3. Platen Motor Control

A stepping motor for platen driving controls the forward and reverse rotation and rotation speed when a system control (IC304) controls driving transistors (Q404 through Q407).

IC304	Signal line	State			
22pin	PM1	L	L	H	H
23pin	PM2	H	H	L	L
24pin	PM3	L	H	H	L
25pin	PM4	H	L	L	H

Forward rotation ←—————→ Reverse rotation

4-4-4. Head Up and Down Control

A head up/down DC motor is driven by its driving circuit (IC400). The DC motor can rotate in the forward and reverse directions. It is controlled by a system control (IC304). The head also has three positions. The head position is detected using optical head position sensors (photo-interrupters PH21 and PH22) and read by a system control (IC304).

Operation of head up/down motor

Head motor	IC304-28pin	IC304-27pin	Operation
UP	L	H	Raises the head.
DOWN	H	L	Lowers the head.
STOP	H	H	Stop

Condition of head position sensor

Position	IC304-17pin	IC304-16pin	Condition
TOP	H	H	Unlocks the door.
MIDDLE	L	H	Wait (Usual)
BOTTOM	H	L	Print

4-4-5. Monitor of Door Sensor

The door position is detected using an optical door position sensor (photo-interrupter PH32) and read by a system control (IC304).

Condition of door position sensor

Position	IC304-20pin	Condition
CLOSE	L	The door is closed.
OPEN	H	The door is open.

4-4-6. Monitor of Paper Sensor

Whether thermosensible paper is properly put in this unit is detected using two pairs of optical paper sensors (phototransistors PH31 and PH12) and read by a system control (IC304).

Condition of paper sensor

IC304-18pin	IC304-19pin	Condition
H	H	Paper exists.
For except "H"	For except "H"	No paper

4-4-7. Monitor of Head Temperature Sensor

The change in the resistance value of the thermistor inside a thermal head is converted into a voltage using a head temperature detector circuit (IC401) and read by a system control (IC304). The voltage value is converted from analog to digital. Density (gamma) correction, fan motor control for head cooling, and head-in cleaning discrimination are performed according to the digital value.

4-4-8. Control of Head Fan Motor (for Head Cooling)

The head fan motor is operated when a system control (IC304) controls driving transistors (Q400 and Q403). The head fan motor is turned on when the head temperature is more than approximately 50 °C or during printing.

Operation of head fan motor

IC304-26 pin	Operation
L	OFF
H	ON

4-4-9. Control of Video Circuit Section

A system control (IC304) controls the video circuit section as shown in the table below.

IC304	I/O	Function	
77pin	O	Switches THRUE and EE signals.	L: ON H: OFF
59pin	O	Sets the trap filter to ON or OFF.	L: ON H: OFF
60pin	O	Selects NTSC or PAL.	L: When an NTSC signal is input H: When a PAL signal is input
53pin	O	Sets the AGC function to ON or OFF.	L: ON H: OFF

4-4-10. Control of Memory and Head Control Circuit

A system control transfers operation mode data in serial to the memory and head control circuit (IC501). It then instructs the start and end of the fetch operation (that fetches a video signal to memory) and copy operation (that feeds the memorized image to the head). The copy operation is carried out when the COPY key is pressed. The fetch-to-copy operation is carried out when the PRINT key is pressed.

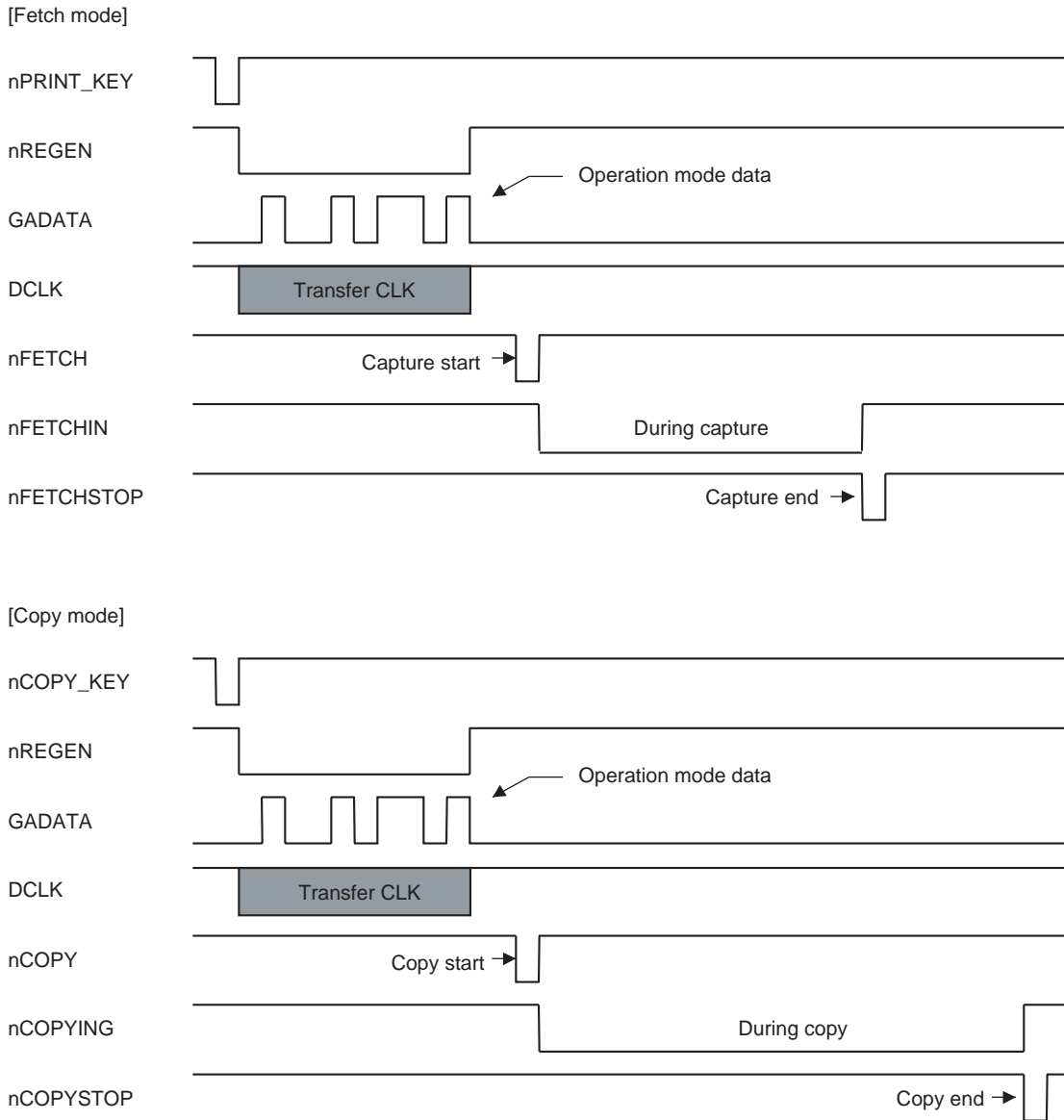

4-4-11. Gamma Correction and Thermal Storage Correction

To correct the gamma fluctuations due to the temperature change in a head, a system control reads the head temperature and transfers the gamma data for controlling the stair density to a memory and head control circuit (IC501). The gamma data consists of 17 data (T_0 , and T_1 through T_{16}). Data T_1 through T_{16} are transferred during print start. During printing, T_x is transferred at the falling edge of an nPRNT_PULSE pulse in the first line, and T_0 is transferred at the falling edge of an nPRNT_PULSE pulse in the second line. If the first line is printed by T_0 , the change in color becomes insufficient. Therefore, the first line is printed by T_x obtained when T_0 is corrected. The second or later lines are printed by T_0 .

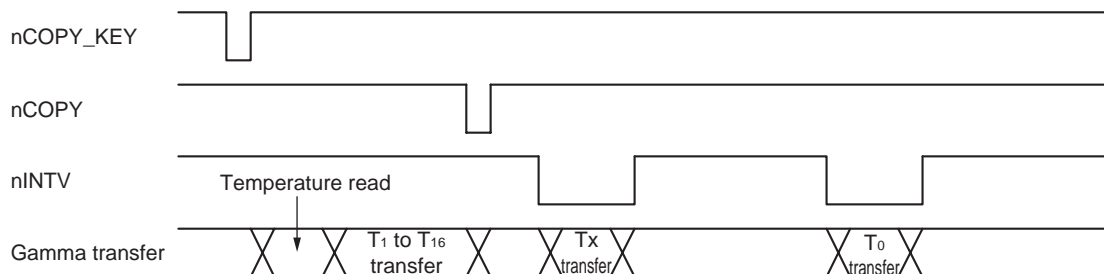

4-4-12. Discrimination of Video Signal to be Input

A system control (IC304) discriminates a video signal by the signals below that are output from a memory and head control circuit (IC501).

IC304	Signal line	Discrimination
21pin	nEXTV	V period is long: PAL V period is short: NTSC
52pin	V	Fixed in L or H: Non-interlacing L and H are repeated: Interlacing

4-4-13. Remote Interface

A system control (IC304) accepts a signal when a low pulse of more than 100 msec is input to the remote terminal (J300). After about 80 msec from the falling edge of the input pulse, the system control (IC304) activates a BUSY signal. The BUSY signal is cleared after printing is completed.

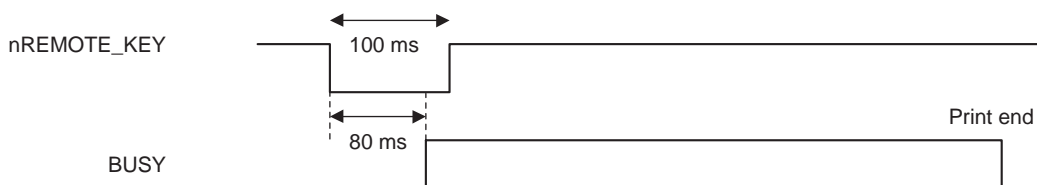

4-4-14. Storage of Print Count History

A system control (IC304) stores the history of print count in EEPROM (IC305). The data is not erased even if the power is turned off. Therefore, this makes it possible to monitor the history of print count since shipping of products. This method can be displayed using the service person mode (self-diagnostic function). For more details, refer to Section 6.

4-5. Thermal Head Section

4-5-1. Structure

The thermal head consists of one-line 1280 dots (64 bits \times 20). It includes the 20 pairs below. (The DATA input is ten DATA [20:1], and other terminals are common.)

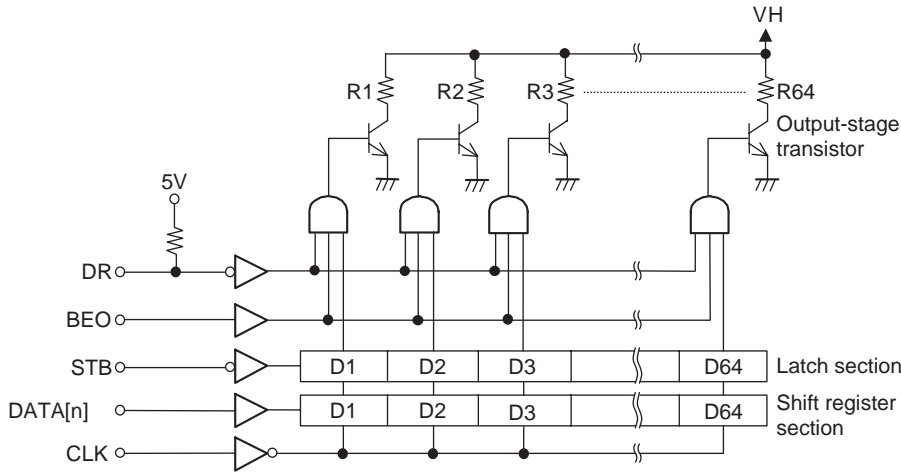

Internal Circuit Configuration of Thermal Head (One-port)

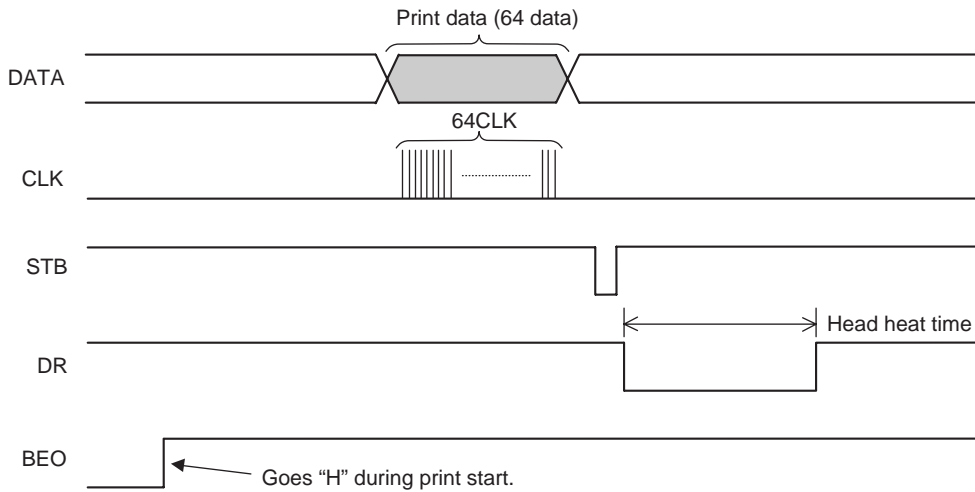

Timing Chart

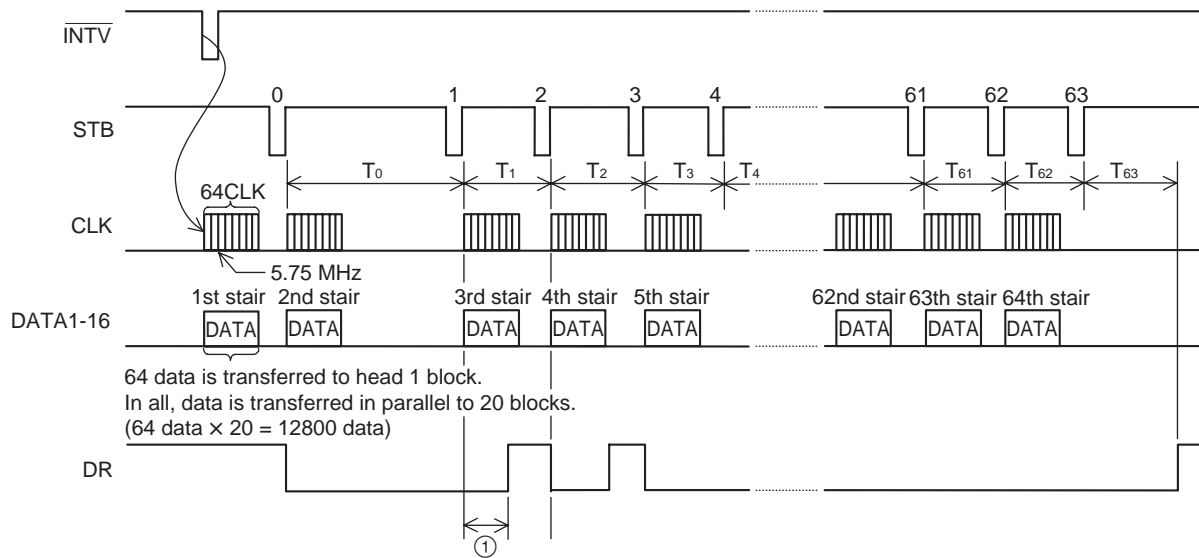

Stair Generation

4-5-2. Basic Operation

Various signals are input from the memory and head control circuit (IC501) to the head. This section describes the operation in only one block. (The operation in other blocks is also the same as described above.)

- (1) Print data (64 data) is input to the shift register section in synchronization with a clock.
- (2) When a STB pulse is input, the data input in step (1) is moved from the shift register section to the latch section.
- (3) When a DR pulse is input, the output-stage transistors are turned on and off by the “H” and “L” data in the latch section. The resistors then heat up and the thermosensitive paper changes color. The amount of heat generated is controlled by changing the length of the DR pulse, so the color darkness of the printing on thermosensitive paper can be changed.

Note

The BEO terminal goes from “L” to “H” when starting the print and goes from “H” to “L” when print is ended.

4-5-3. Stair Generation

As explained in the last section on basic operation, the darkness of the printing can be controlled using a DR pulse, it is also possible to change the darkness by changing the “H” and “L” data input to the latch section. The method is described below.

- (1) One-line image data recorded in image memory SDRAM (IC503) is fetched to the line memory in IC501 every print operation one line (nPRINT_PULSE) by controlling a memory and head control circuit (IC501).
- (2) The data fetched to the line memory is input to the stair generator circuit in IC501. The stair data generator circuit outputs the 8-bit data fetched to the line memory as stair data 1 through 64. If 8-bit data is 128, “H” data is output to the head in the 1st through 32nd stairs of data 1 through 16. “L” data is output in the 33rd and later stairs.
- (3) The data output from the data generator circuit to the head is transferred to the shift register section of the head in synchronization with the clock output from IC501.

- (4) When IC501 inputs STB pulse “1” to the head, the 1st stair data is transferred to the latch section and the next 2nd stair data is input to the shift register section. At the same time, the DR pulse goes low, and the “H” data input as the 1st stair data turns on the corresponding output-stage transistors to heat up the resistors. The “L” data turns off the corresponding output-stage transistors so that the resistors do not heat up.

This operation is carried out 1 through 64 times. If “H” data is sent 1 through 64 times, the resistors generate heat at all times and the printing is the darkest possible. If “H” data is sent 1 through 32 times, the printing is an intermediate stair (gray). In such a way, the stair data with the number of sending times corresponding to the size of the original 8-bit data is sent to the head, and the intermediate stair is represented by the number of heat generation times in a heat generator.

- (5) Thus, by controlling the time until the next data is transferred to the latch, the darkness of intermediate stairs can be controlled. In other words, the darkness of each intermediate stair can be changed by changing the STB intervals ($T_1, T_2, T_3, T_4, T_5 \dots T_{64}$) shown in the figure.

In this unit, IC502 controls intervals T_1 to T_{64} according to the γ characteristics of paper. This is called a γ characteristic control.

- (6) If the DR pulse is also controlled as described in “4-5-2. Basic Operation”, finer stairs can be expressed.

Portion ① in the figure is generated when the T interval of a STB pulse is shorter than the transmission time to the shift register.

Therefore, this unit provides the smooth expression of intermediate stairs by controlling the STB pulse’s T interval and DR pulse.

4-5-4. Temperature Correction

As explained in “4-5-3. Stair Generation”, intermediate stairs are expressed by controlling the STB pulse’s T interval and DR pulse. However, the print energy required for thermosensitive paper varies with the room temperature and with the heat generated by and stored in the printing head during continuous printing. Correction is thus required.

In this unit, a system control (IC304) measures the temperature change of the head from the thermistor incorporated into the thermal head and converts it into 8-bit head temperature data. Moreover, IC304 reflects it on the γ characteristic control of IC501 and corrects the density change for the temperature.

As in stair generation, IC501 performs the temperature correction by controlling the STB pulse’s T interval and DR pulse. In other words, when the temperature rises, the STB pulse’s T interval and DR pulse decrease. When the temperature falls, the STB pulse’s T interval and DR pulse increase.

4-5-5. Line Count Correction

The total current flowing through the head when all resistors of the head are turned on differs from the case where they are turned on partially. Therefore, an error occurs in the energy applied to each resistor. If printing operation is performed without correcting this error, as a result, there is a line on the print where the number of resistors in which the head is turned on changes rapidly. This unit has IC501 that incorporates this correction circuit.

Section 5 Troubleshooting

5-1. Print is Faulty

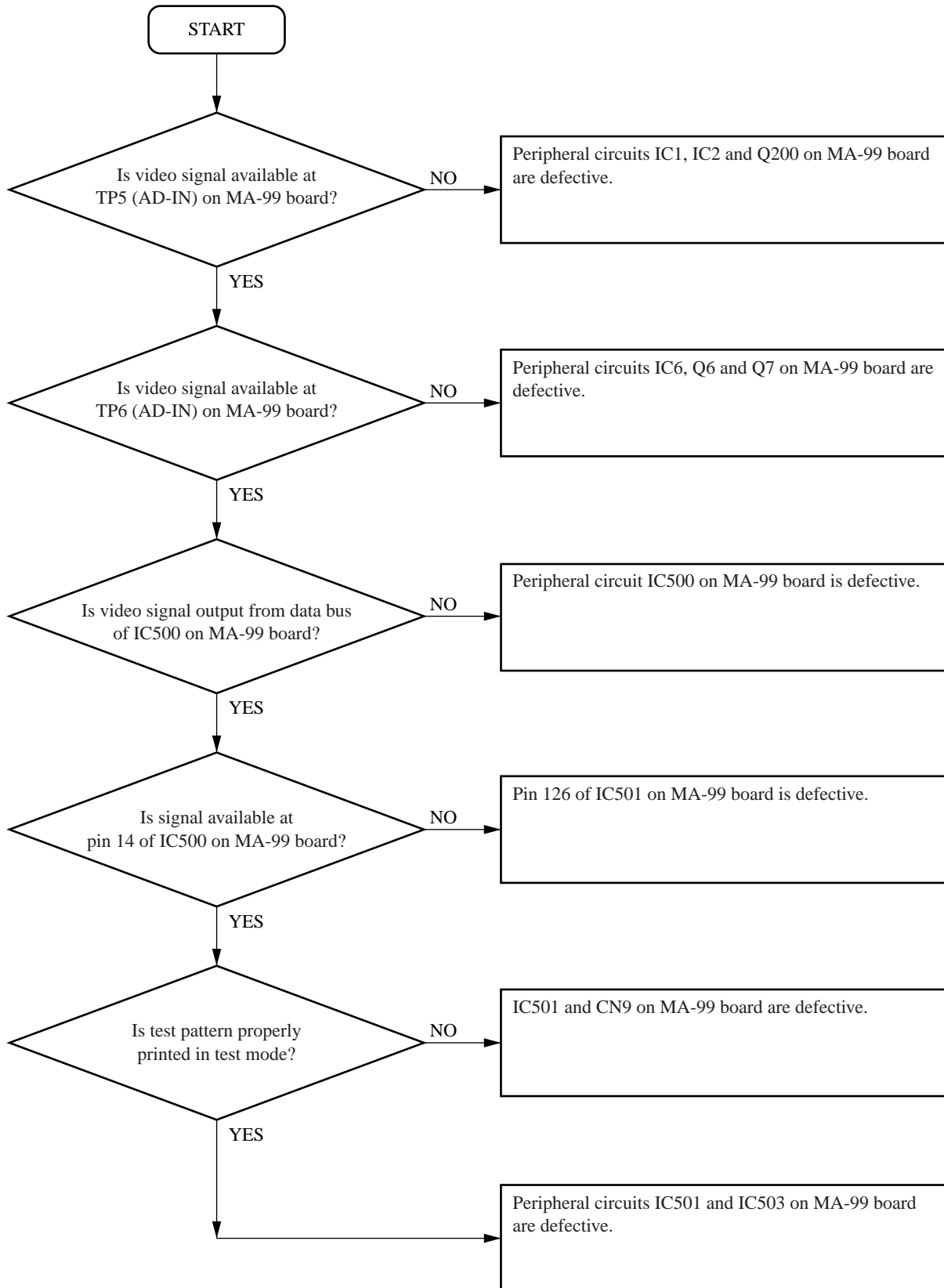

5-2. Print is Too Dark or Too Light

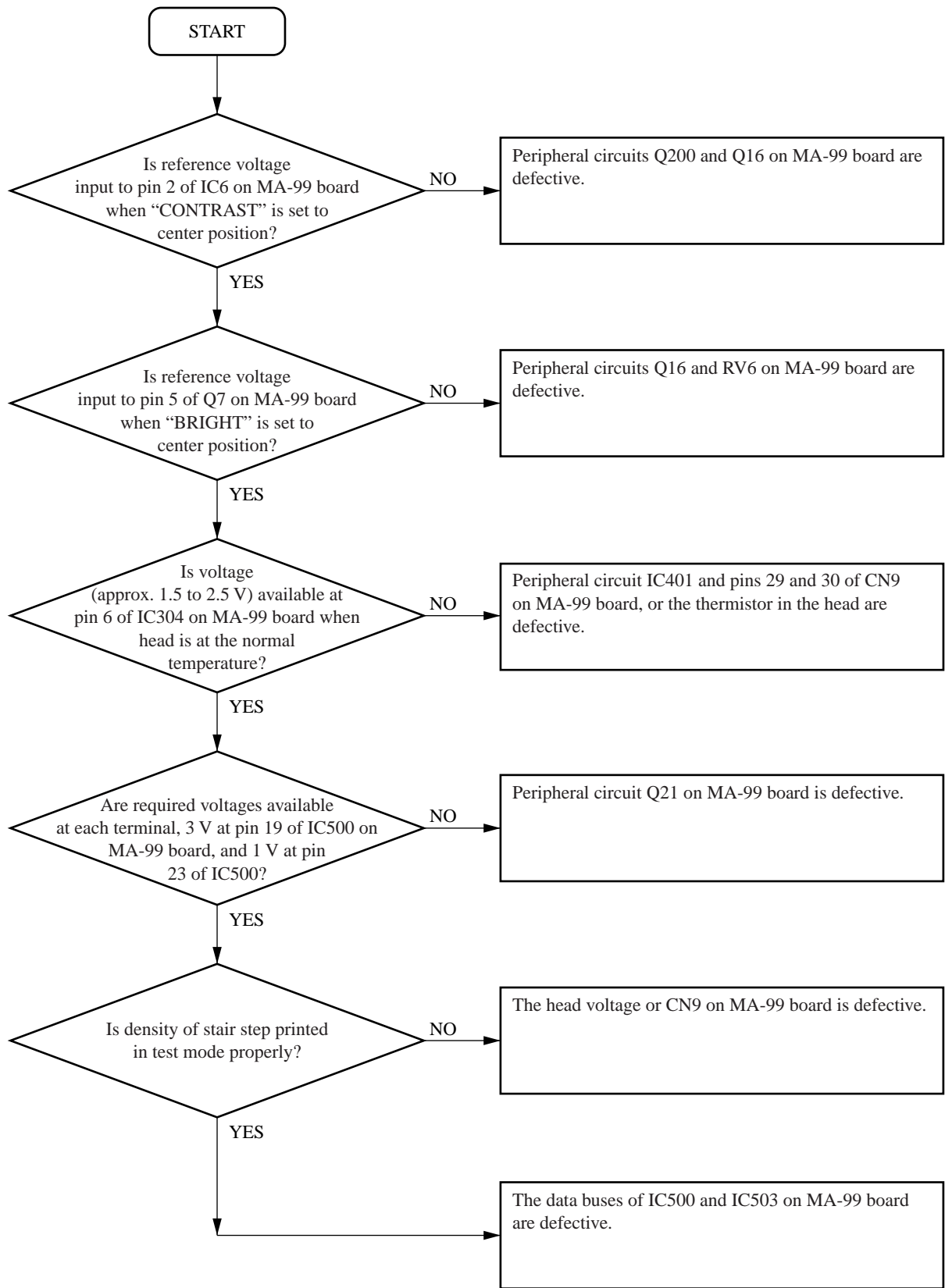

5-3. "Paper Sensor" is Out of Order

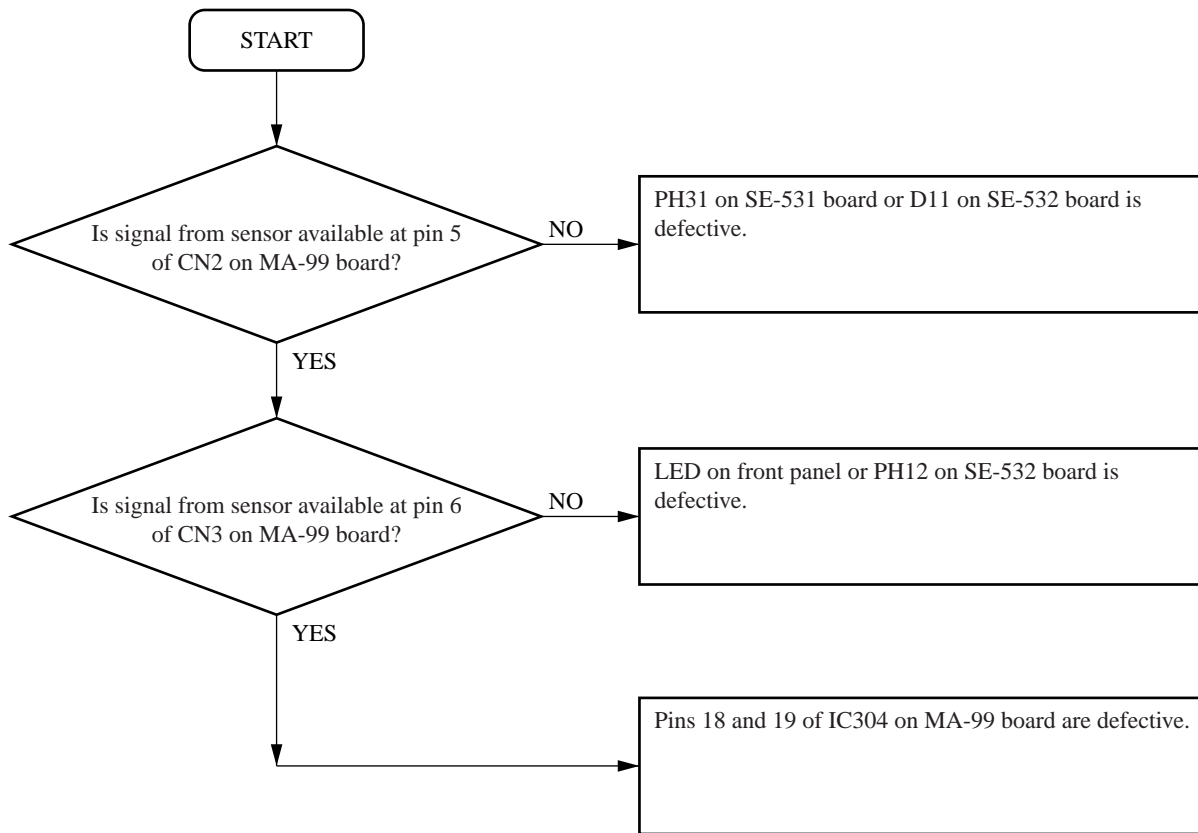

5-4. Head Operation (Up & Down) is Out of Order

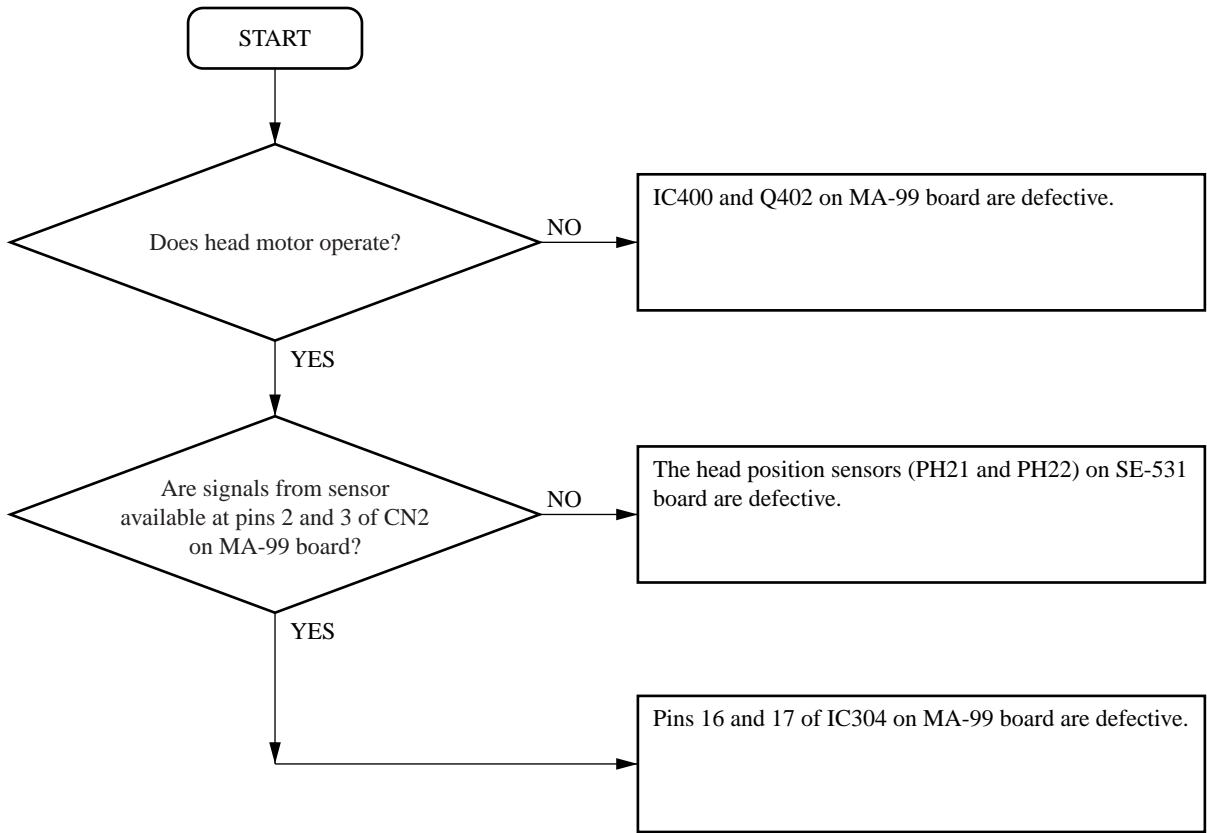

5-5. Paper Feeding is Out of Order

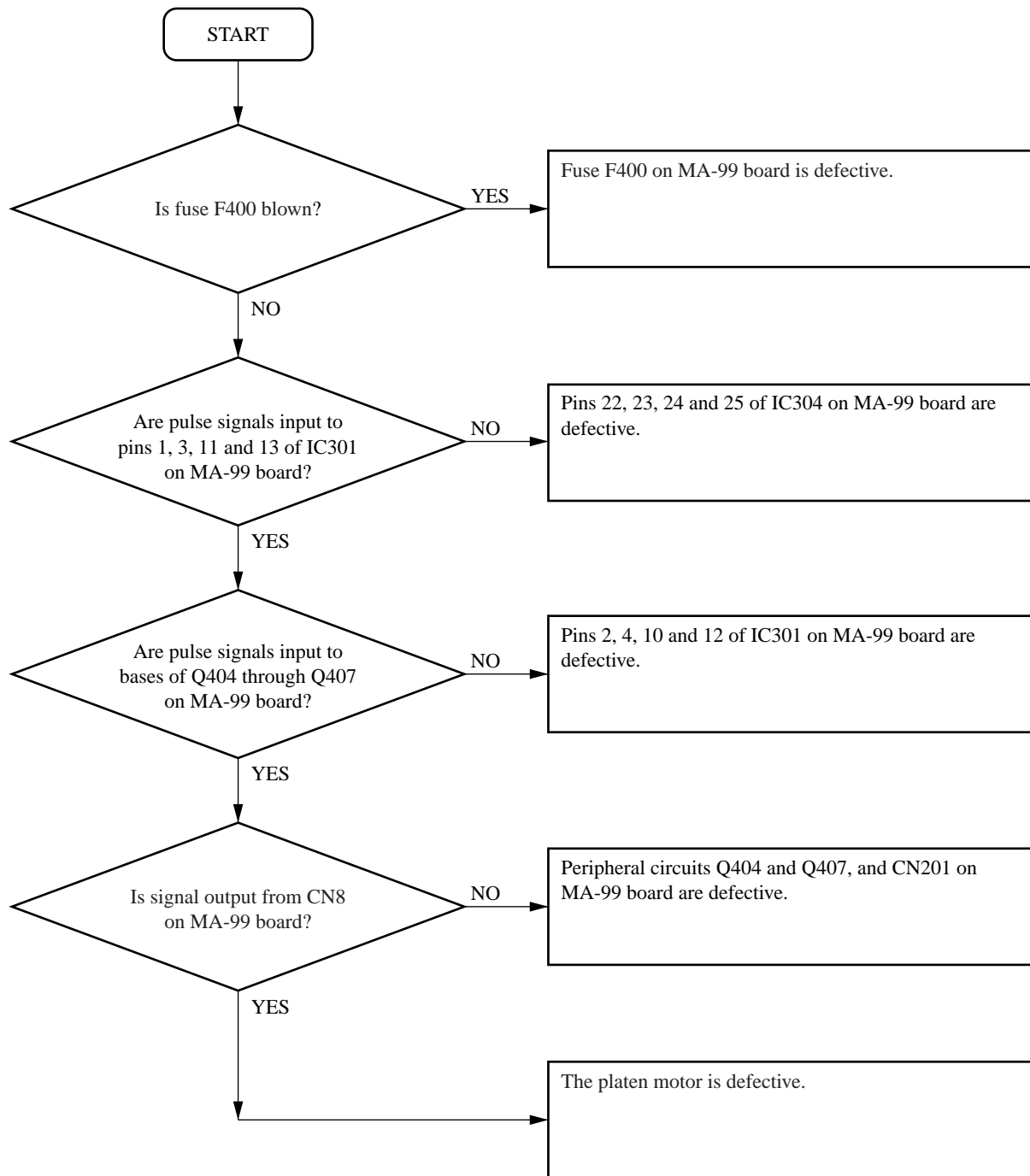

5-6. Door (Opening and Closing) is Out of Order

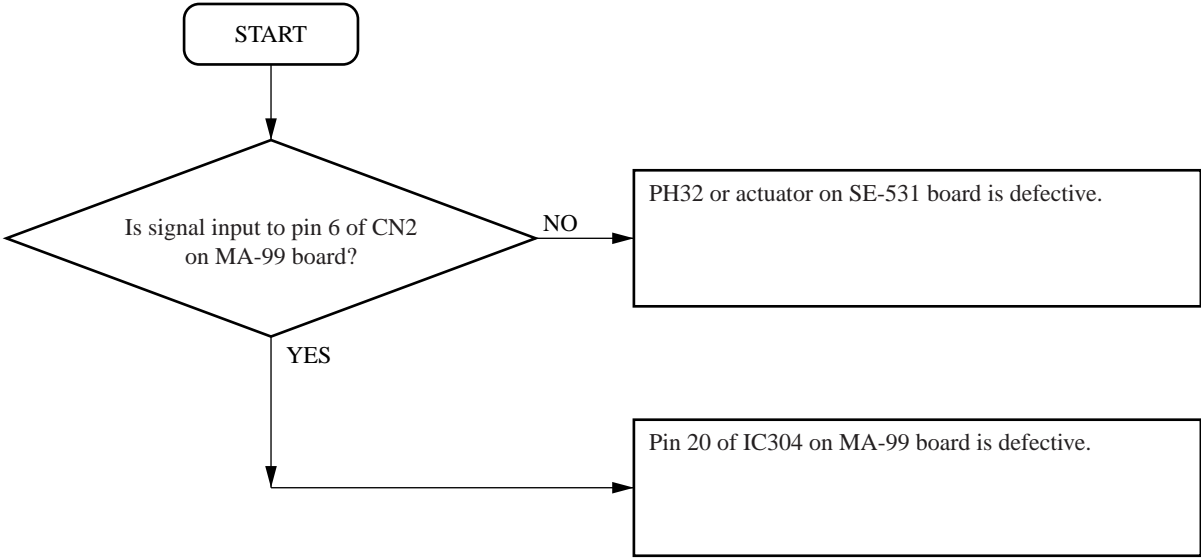

Section 6

Service Mode (Self-diagnostic Function)

Turn on the power while pressing and holding the PRINT and COPY keys. Release the keys when the buzzer sounds after about two seconds. The service mode is then entered.

6-1 Printing the Test Pattern

Set the POSI/ENGA switch to POSI (no print can be performed when this switch is set to NEGA). “Stair step” and “Gray” are available as a test pattern for printing.

① Press the PRINT key. → Print the stair step pattern.

② Press the COPY key. → Print the gray pattern.

For the gray pattern, the concentration of gray can be selected from 100 % white to 100 % black in five steps using the PRINT SIZE switch.

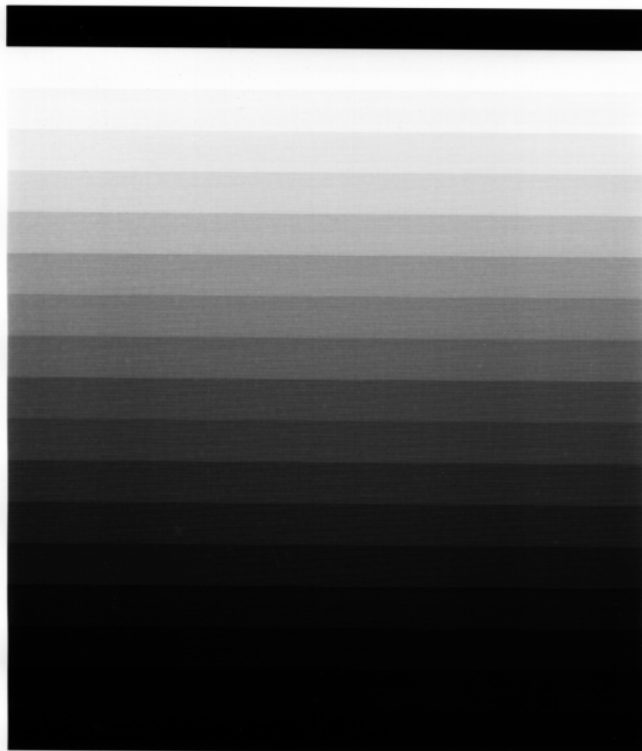
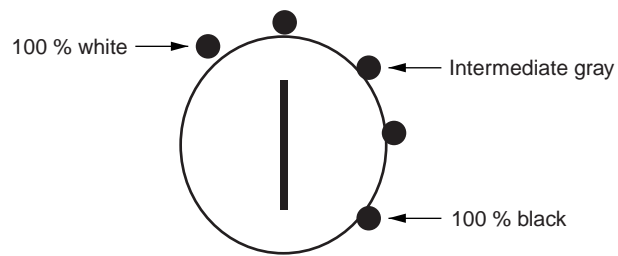

Stair step

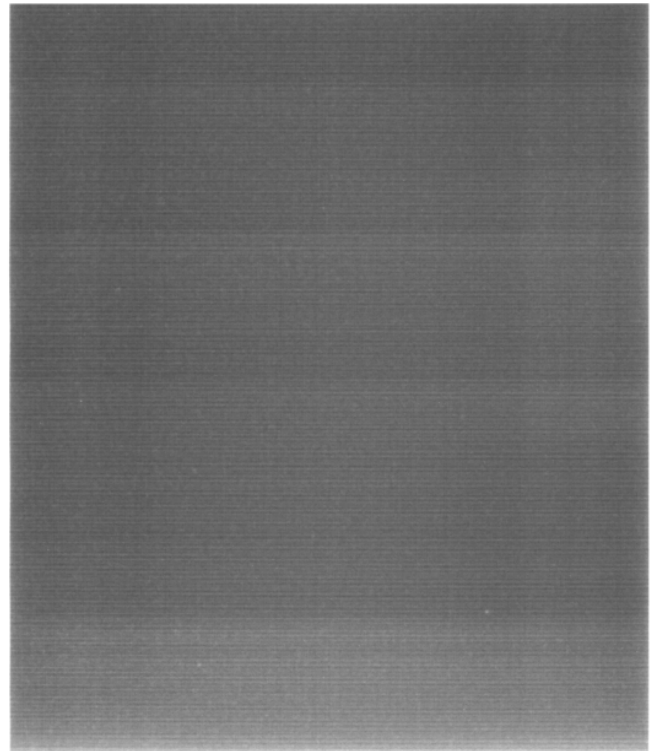

Gray

6-2. Up/Down Operation of Head

Set the POSI/NEGA switch to NEGA (a test pattern is printed when this switch is set to POSI). The PRINT key is used as the head DOWN key, and the COPY key as the head UP key. The head can be put in the TOP, MIDDLE (home), or BOTTOM position. It can be moved up and down using the PRINT/COPY key.

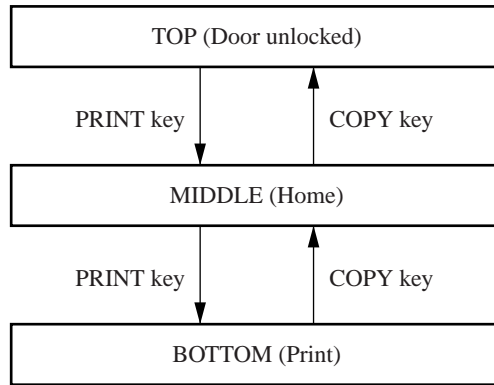

6-3. Feed Operation

Press the FEED key. The stepping motor then starts and the platen rotates. The service mode can also be operated with the door opened. Moreover, the forward and reverse rotations can be switched using the POSI/NEGA switch. (The platen rotates in the delivery direction when the switch is set to POSI. The platen rotates in the retracting direction when it is set to NEGA.)

6-4. Display and Clearing of Print Sheet History

① Display of print sheet history

Set the PRINT SIZE switch to SML (SMALL mode). Next, press the PRINT key to print the stair step shown in the figure below. One step indicates 10,000 sheets of paper. The white line position indicates the sheet of paper that has been printed. The sheet of print paper can be displayed in the range of 0 to 150,000. The sheet of print paper exceeding 150,000 is displayed as 150,000.

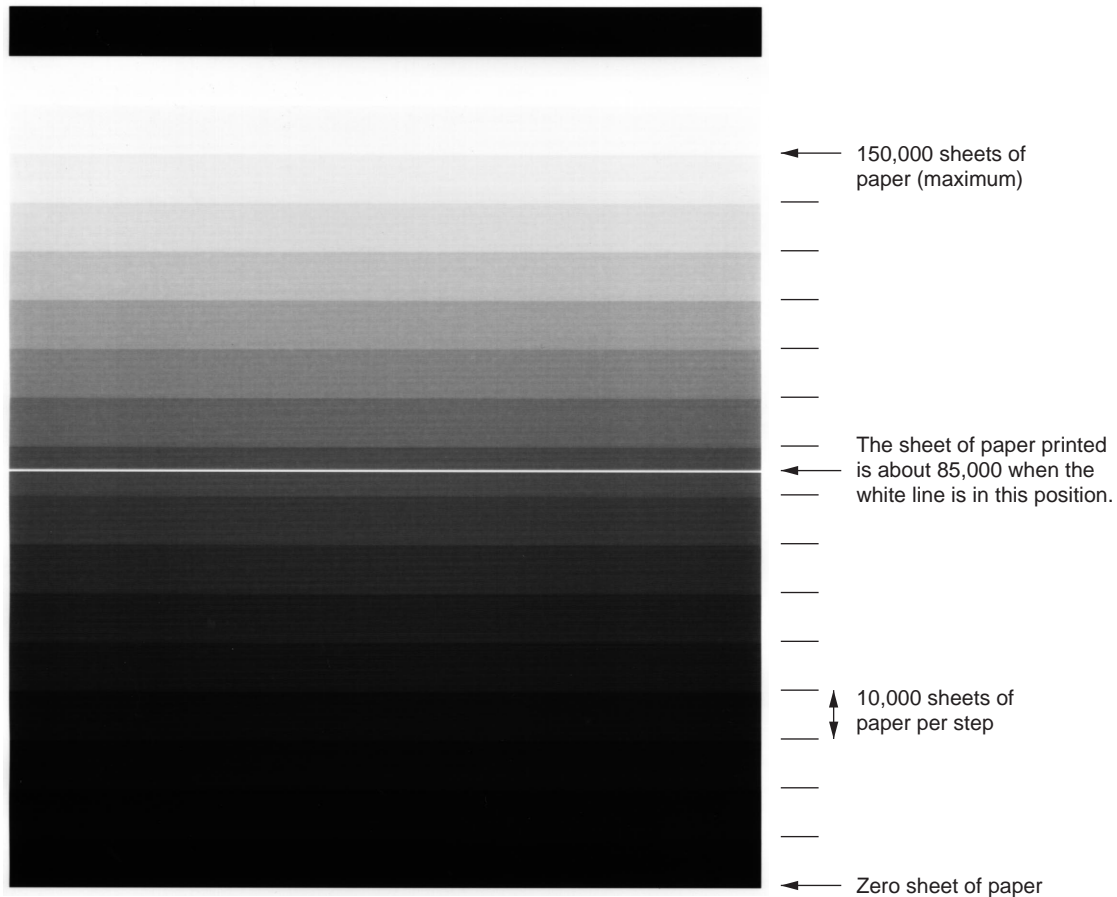

② Clearing of print sheet history

In the power off state, turn on the power with the PRINT, COPY, and FEED keys pressed.

Section 7

Semiconductor Pin Assignments

The following describes the semiconductor types used in this unit.

For semiconductors marked with page numbers in the index, refer to the corresponding pages in this section.

However, in some cases incompatible types are also listed, therefore, when a part is to be replaced, also refer to the Spare Parts section.

In addition, for semiconductors with ID Nos., refer to the separate CD-ROM titled "Semiconductor Pin Assignments" (Sony Part No. 9-968-546-xx) that allows searching for parts by semiconductor type or ID No.

The semiconductors in the manual or on the CD-ROM are listed by equivalent types. Thus the external view or the index mark indication may differ from the actual type.

Pin assignments and block diagrams are based on the IC manufacturer's data book.

本機に使用されている半導体型名の一覧を下記に示します。索引中、ページが記載されている半導体は、本章の該当ページを参照してください。ただし、互換性のない型名を併記している場合がありますので、部品を交換するときは、Spare Partsの章を参照してください。

また、ID番号が記載されている半導体は、別途発行の "Semiconductor Pin Assignments" CD-ROM版 (ソニー部品番号：9-968-546-xx)を参照してください。半導体型名またはID番号から検索ができます。

マニュアルまたはCD-ROMに掲載されている半導体は、それぞれの機能を等価的に表わしたものです。

外観やインデックスマークの表示方法が実物と異なる場合があります。

ピン配置およびブロック図はICメーカーのデータブックに従いました。

DIODE	Page or ID No.	IC	
10E-2	DA001-01	BA7655AF-E2	BA7655AF
10E-2FD	DA001-01	CXD1171M	CXD1171M
1S2836	DC001-02	CXD1171M-TH	CXD1171M
1S2836-T1	DC001-02	CXD8932Q	CXD8932Q
1SS302	DC001-01		
1SS302-TE85L	DC001-01	DS1000Z-100	DS1000M-100
		DS1000Z-100(TE2)	DS1000M-100
LED		HA11465A	HA11465A
GL-520	LR008-01		
TRANSISTOR	Page or ID No.	LM358PS	LM358N
2SA1162G	TC001-01	LM358PSR	LM358N
2SA812-T1-M5M6	TC001-01	M24C02-MN6T	7-2
2SC1623-L5L6	TC001-02	M54543L	M54543L
2SC1623-T1-L5L6	TC001-02	MB40C568HPF-ER	MB40C568HPF-ER
2SD992-Z	TR031-05	MB81F64842D-102FN	7-2
2SD992-Z-E2	TR031-05	MC14053BF	CD4053BE
2SD999-CLCK	TC002-02	MC14053BFEL	CD4053BE
2SD999-T1-CLCK	TC002-02		
DTC124EKA-T146	TC001-03	NJM2234M	NJM2234M
PT493F	TR037-01	NJM2234M(TE2)	NJM2234M
PT501A	TR006-02	NJM7812FA	NJM78M05FA
XN4402-(TX)	TC006-05	PQ3RF33	PQ05RF1
XN4501	TC005-01	PST600DMT-T1	PST600D
XN4501-TW	TC005-01		
XN4601	TC006-06	RPI-5100	RPI5100
XN4601-TW	TC006-06	SN74HC14ANS	TC74HC14P
		SN74HC14ANSR	TC74HC14P
		SN74HC251ANSR	TC74HC251P
OTHER		TC74VHC174FT(EL)	TC74HC174P
RPI-352	MR010-07	TC7S00FU(TE85R)	TC7S00F
		TC7S14FU(TE85R)	TC7S14FU

IC

M24C02-MN6T
M24C02-MN6T (THOMSON)

2K-BIT SERIAL BUS EEPROM
—TOP VIEW—

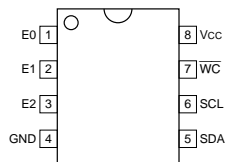

INPUTS
E0 - E2 : CHIP ENABLE
SCL : SERIAL CLOCK
WC : WRITE CONTROL

INPUT/OUTPUT
SDA : SERIAL DATA ADDRESS

MB81F64842D-102FN
MB81F64842D-102FN (FUJITSU)

64M (4 × 2097152 × 8) -BIT SDRAM
—TOP VIEW—

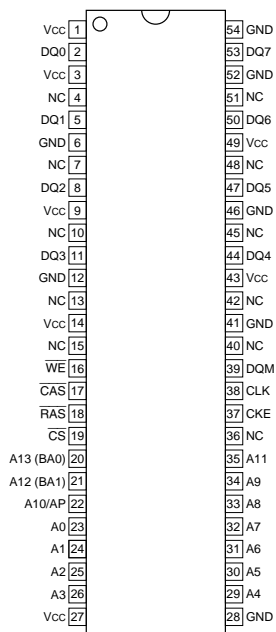

INPUTS
A0 - A11 : ADDRESS
A12 (BA1), A13 (BA0) : BANK SELECT (BANK ADDRESS)
AP : AUTO PRECHARGE ENABLE
CAS : COLUMN ADDRESS STROBE
CKE : CLOCK ENABLE
CLK : CLOCK
CS : CHIP SELECT
DQM : DQ MASK
RAS : ROW ADDRESS STROBE
WE : WRITE ENABLE

INPUTS/OUTPUTS
DQ0 - DQ7 : DATA

OTHER
NC : NO CONNECTION

PIN NO.	I/O	SIGNAL	PIN NO.	I/O	SIGNAL	PIN NO.	I/O	SIGNAL
1	—	Vcc	19	I	CS	37	I	CKE
2	I/O	DQ0	20	I	A13 (BA0)	38	I	CLK
3	—	Vcc	21	I	A12 (BA1)	39	I	DQM
4	—	NC	22	I	A10/AP	40	—	NC
5	I/O	DQ1	23	I	A0	41	—	GND
6	—	GND	24	I	A1	42	—	NC
7	—	NC	25	I	A2	43	—	Vcc
8	I/O	DQ2	26	I	A3	44	I/O	DQ4
9	—	Vcc	27	—	Vcc	45	—	NC
10	—	NC	28	—	GND	46	—	GND
11	I/O	DQ3	29	I	A4	47	I/O	DQ5
12	—	GND	30	I	A5	48	—	NC
13	—	NC	31	I	A6	49	—	Vcc
14	—	Vcc	32	I	A7	50	I/O	DQ6
15	—	NC	33	I	A8	51	—	NC
16	I	WE	34	I	A9	52	—	GND
17	I	CAS	35	I	A11	53	I/O	DQ7
18	I	RAS	36	—	NC	54	—	GND

Section 8

Spare Parts

8-1. Notes on Repair Parts

1. Safety Related Components Warning

WARNING

Components marked \triangle are critical to safe operation. Therefore, specified parts should be used in the case of replacement.

2. Standardization of Parts

Some repair parts supplied by Sony differ from those used for the unit. These are because of parts commonality and improvement.

Parts list has the present standardized repair parts.

3. Stock of Parts

Parts marked with "o" at SP (Supply Code) column of the spare parts list may not be stocked. Therefore, the delivery date will be delayed.

4. Harness

Harnesses with no part number are not registered as spare parts.

In need of repair, get components shown in the list and repair using them.

8-2. Exploded Views

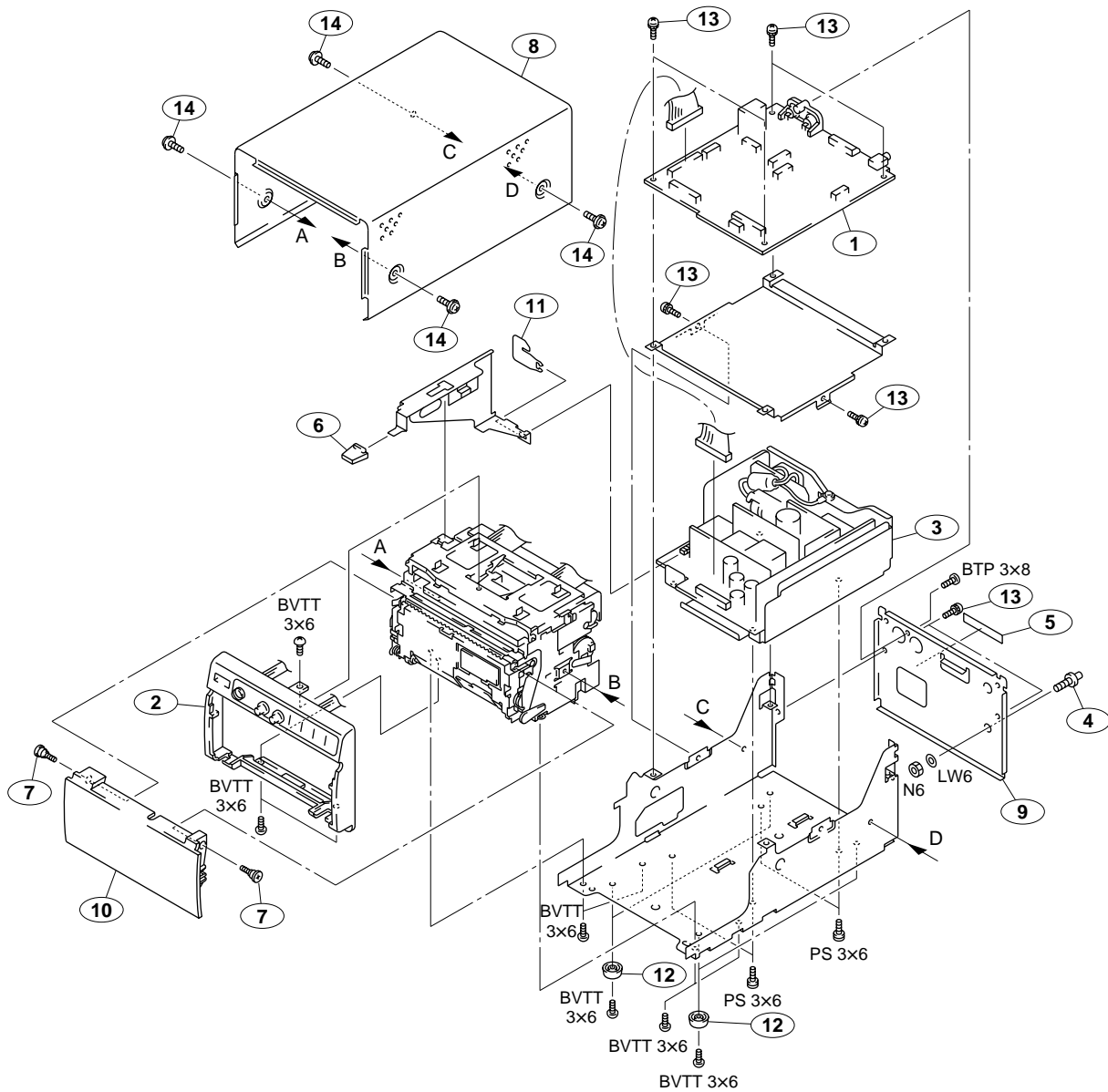

No.	Part No.	SP Description
1	A-8323-913-A	o MOUNTED CIRCUIT BOARD, MA-99
2	1-418-820-11	s PANEL UNIT, FRONT
3	△ 1-468-456-12	s REGULATOR, SWITCHING
4	3-175-740-01	o TERMINAL [for UP-895MD(UC,SY), UP-895CE(CE)]
5	3-179-847-01	o LABEL(NORTHERN EUROPE),CAUTION [for UP-895CE(CE), UP-895MD(SY)]
6	3-187-313-21	o BUTTON, POWER
7	3-623-875-02	s SCREW,STEP
8	3-623-889-01	o TOP COVER
9	3-623-894-02	o PANEL,REAR [for UP-895CE(CE), UP-895MD(UC,SY)]
	3-623-894-12	o PANEL,REAR [for UP-895(J,UC), UP-895MD(J)]

No.	Part No.	SP Description
10	3-623-912-03	s PANEL,DOOR [for UP-895(J,UC)]
	3-623-912-13	s PANEL,DOOR [for UP-895MD(J,UC,SY)]
	3-623-912-23	s PANEL,DOOR [for UP-895CE(CE)]
11	3-623-919-01	o STOPPER,ROD
12	3-734-866-01	s FOOT
13	4-034-937-01	s SCREW (M3X8), TAPPING (ST)
14	4-886-821-11	s SCREW,M3X6 CASE (SILVER)

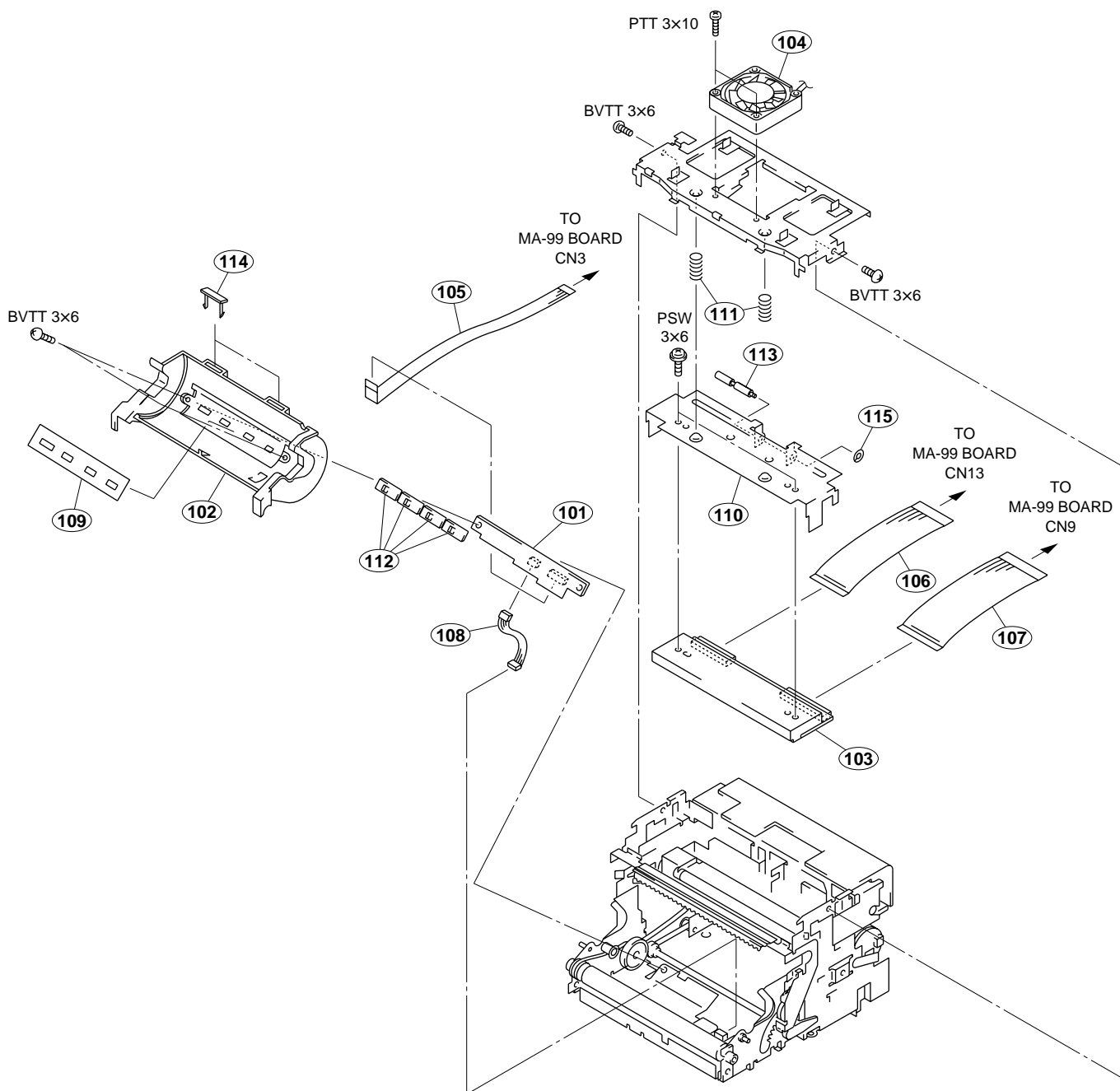

No.	Part No.	SP Description
101	A-8323-915-A	o MOUNTED CIRCUIT BOARD, KY-454
102	X-3605-752-1	o ASSY, PAPER TRAY
103	1-251-855-11	s HEAD, THERMAL (LVE6413SS)
104	1-763-007-21	o FAN, DC (OPTION)
105	1-792-200-11	o WIRE, FLAT TYPE (8 CORE)
106	1-792-201-11	o WIRE, FLAT TYPE (26 CORE)
107	1-792-202-11	o WIRE, FLAT TYPE (30 CORE)
108	1-960-221-11	o HARNESS, SUB (3P)
109	3-623-867-02	o SEAT, SWITCH
110	3-623-890-01	s HEAT SINK

No.	Part No.	SP Description
111	3-623-899-01	s SPRING, COMPRESSION
112	3-623-908-02	s COVER, SWITCH
113	3-623-924-02	o SHAFT, HEAD FULCRUM
114	3-624-816-01	s STOPPER, ROLL
115	4-926-219-02	s RING (DIA.2.3), RETAINING

Inner Chassis Block

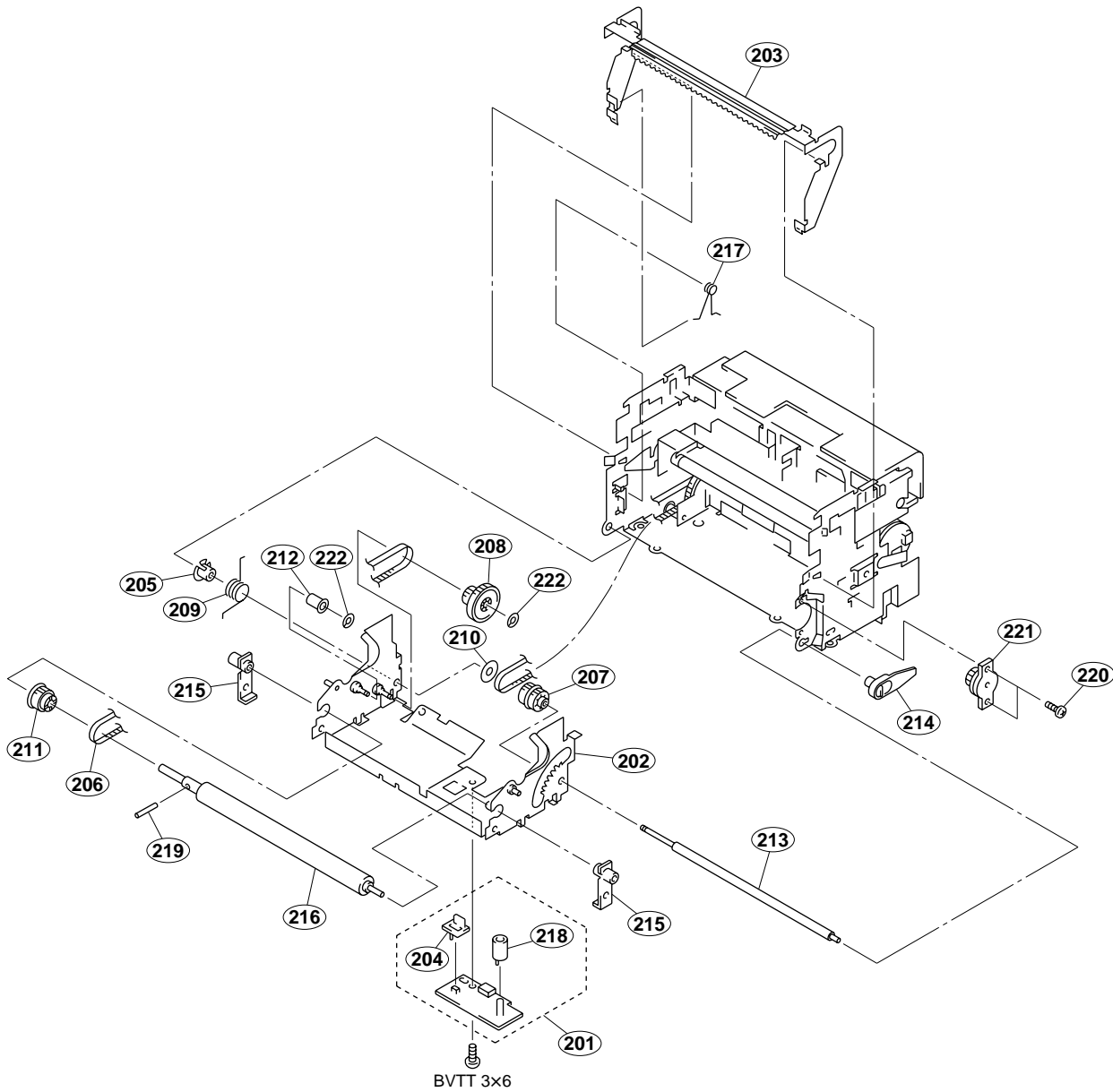

No.	Part No.	SP Description	No.	Part No.	SP Description
201	A-8323-917-A	o MOUNTED CIRCUIT BOARD, SE-532	211	3-623-893-02	s PULLY, PLATEN
202	X-3605-674-2	s ASSY, INNER CHASSIS	212	3-623-900-01	s ROLLER, TENTION
203	X-3605-675-1	s ASSY, CUTTER	213	3-623-902-01	o SHAFT, INNER
204	3-187-312-02	s HOLDER (P), LED	214	3-623-903-01	s BEARING, INNER SHAFT(POM)
205	3-623-873-01	s SPACER, INNER SHAFT(POM)	215	3-623-904-01	s BEARING, PLATEN(PLASTIC)
206	3-623-879-01	s BELT, 110TN10-4.0K(PUR)	216	3-623-909-02	s PLATEN
207	3-623-880-01	s IDLE GEAR PULLY	217	3-626-685-01	s SPRING, CUTTER
208	3-623-881-01	s GEAR PULLY 2	218	3-689-205-02	s HOLDER (A), LED
209	3-623-891-01	s SPRING, DOOR OPEN	219	3-703-357-07	s PIN PARALLEL (1.6X10) (STEEL)
210	3-623-892-01	s RING, RETAINING	220	3-719-381-01	s SCREW +P M2X4 (ZNBK)(LOCK)
			221	3-973-975-31	s DAMPER, OIL
			222	4-926-219-02	s RING (DIA.2.3), RETAINING

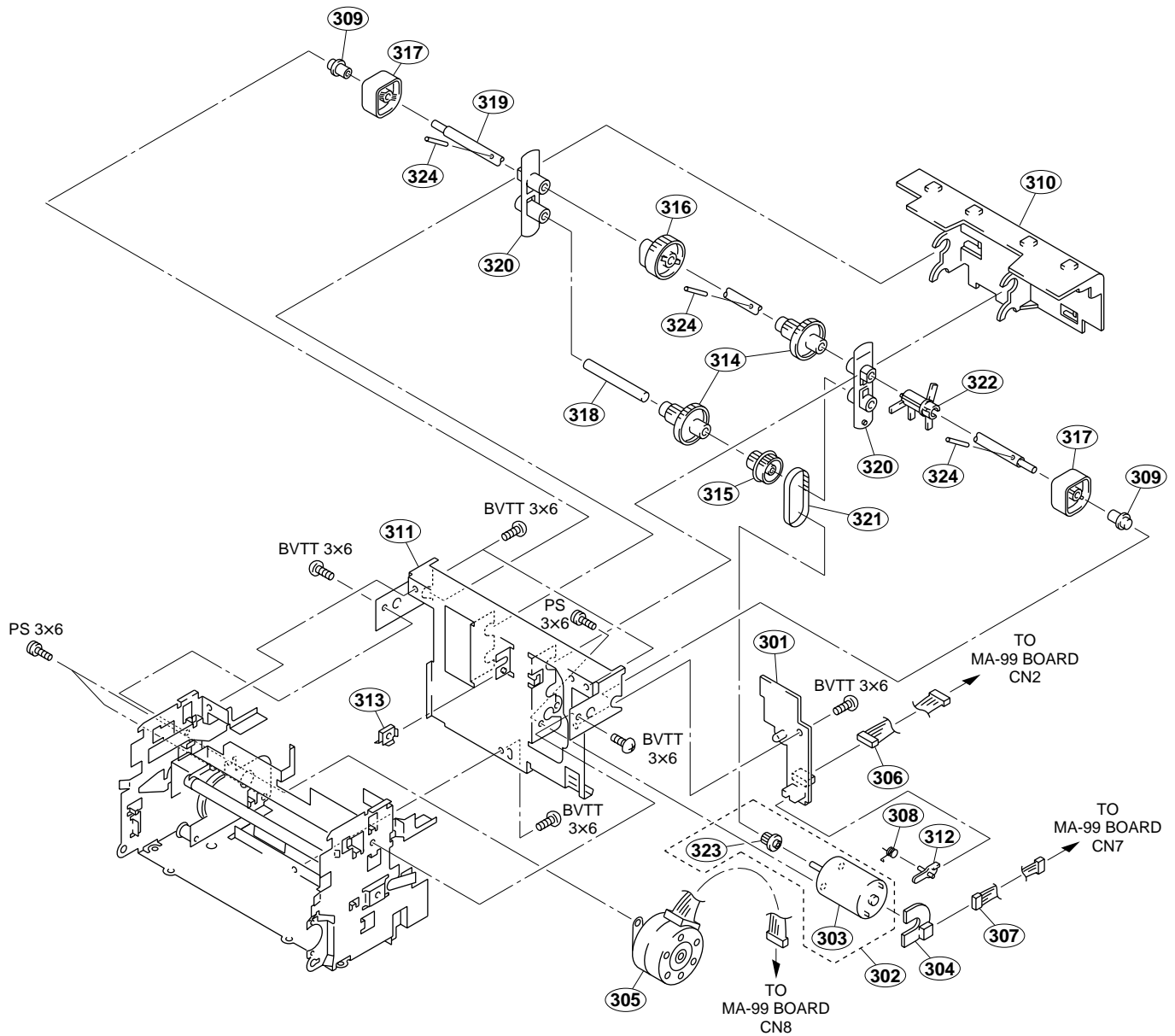

No.	Part No.	SP Description
301	A-8323-916-A	o MOUNTED CIRCUIT BOARD, SE-531
302	X-3605-682-1	s MOTOR ASSY
303	1-541-309-11	s MOTOR, (RF-370C) (DC) (2.59W)
304	1-676-696-11	o PRINTED WIRING BOARD, SU-52
305	1-698-928-22	s MOTOR, STEPPING
306	1-960-220-11	o HARNESS, SUB (6P)
307	1-960-222-11	o HARNESS, SUB (2P)
308	3-613-740-01	s SPRING, HELICAL TORSION A
309	3-613-781-01	s COVER, CENTER SHAFT
310	3-623-868-01	o COVER, GEAR

No.	Part No.	SP Description
311	3-623-886-02	o CHASSIS, REAR
312	3-623-910-01	s LEVER, DOOR SENSOR
313	3-623-922-01	o COVER, FULCRUM PLATE
314	3-623-925-02	s GEAR, HEAD DRIVE
315	3-623-926-02	s PULLY, HEAD DRIVE
316	3-623-927-01	s CAM, PRESS ROLLER
317	3-623-928-02	s CAM, HEAD
318	3-623-929-01	o SHAFT, DRIVE GEAR
319	3-623-930-01	o SHAFT, HEAD CAM
320	3-623-931-02	s BEARING, REAR (POM)
321	3-623-932-01	s BELT, 70TN10-3.5 (PUR)
322	3-623-933-01	s FIN, HEAD SENSOR
323	3-683-773-04	s GEAR, PAPER MOTOR
324	3-703-357-07	s PIN PARALLEL (1.6X10) (STEEL)

Arm Assy and Gear Bracket Block

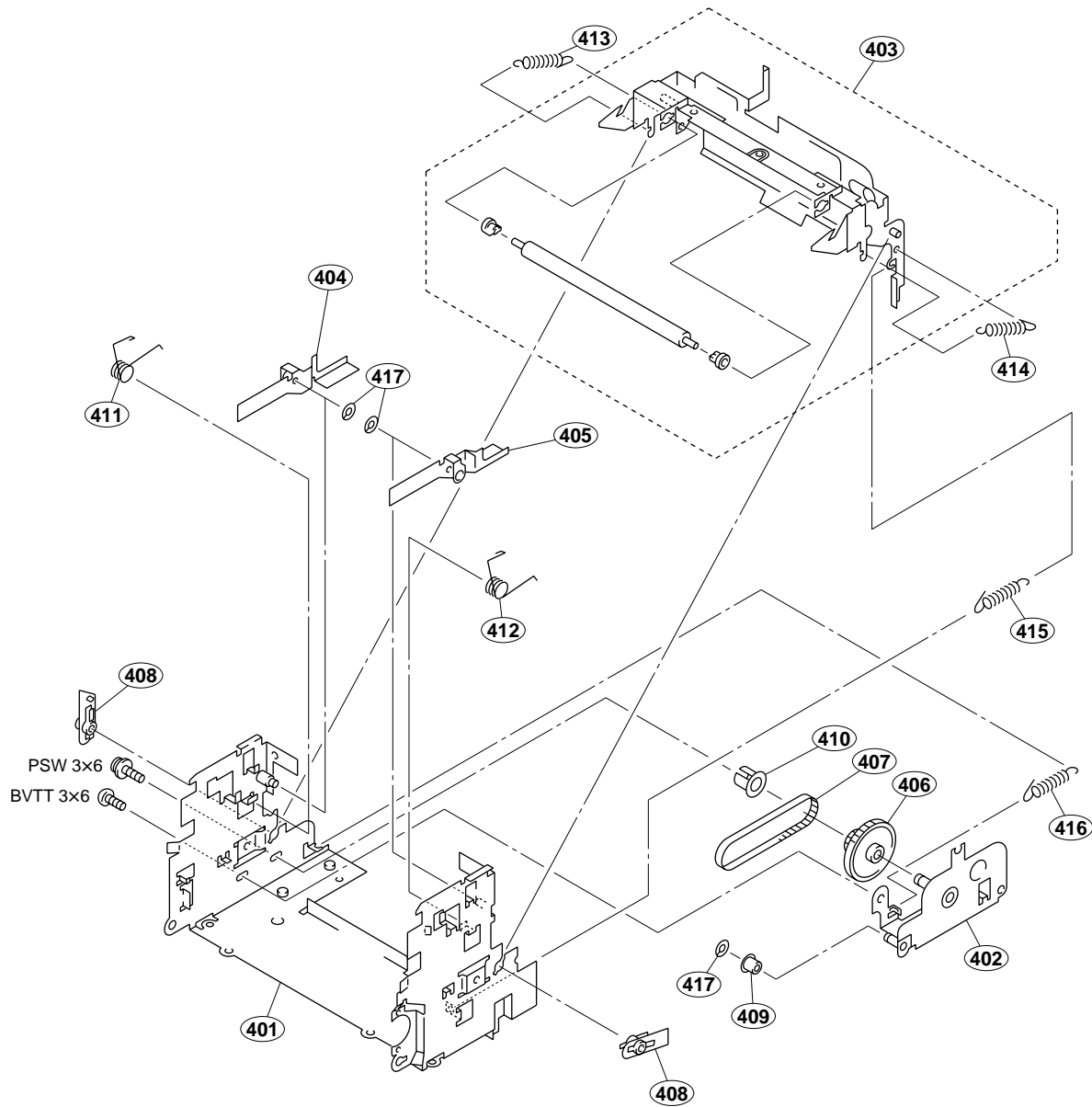

No.	Part No.	SP Description
401	X-3605-671-2	o ASSY,MECHA CHASSIS
402	X-3605-672-2	o ASSY,GEAR BRACKET
403	X-3605-673-1	s ARM ASSY
404	3-623-869-01	o LEVER(L),HEAD UP
405	3-623-870-01	o LEVER(R),HEAD UP
406	3-623-877-01	s GEAR PULLEY 1
407	3-623-878-01	s BELT,140TN10-3.0K(PUR)
408	3-623-885-01	s BEARING,ARM(POM)
409	3-623-900-01	s ROLLER,TENTION
410	3-623-913-01	s ROLLER,GUIDE

No.	Part No.	SP Description
411	3-623-920-01	s SPRING,HEAD PUSH L
412	3-623-921-01	s SPRING,HEAD PUSH R
413	3-624-785-01	s SPRING,EXTENSION
414	3-624-786-01	s SPRING,EXTENSION
415	3-624-917-01	s SPRING,EXTENSION
416	3-624-974-01	s SPRING,EXTENSION
417	4-926-219-02	s RING (DIA.2.3), RETAINING

8-3. Electrical Parts List

KY-454 BOARD

Ref. No. or Q'ty	Part No.	SP	Description
1pc	A-8323-915-A	o	MOUNTED CIRCUIT BOARD, KY-454
C1	1-164-004-11	s	CAPACITOR,CERAMIC 0.1MF/25V
C2	1-164-004-11	s	CAPACITOR,CERAMIC 0.1MF/25V
C3	1-164-004-11	s	CAPACITOR,CERAMIC 0.1MF/25V
C4	1-164-004-11	s	CAPACITOR,CERAMIC 0.1MF/25V
C5	1-164-004-11	s	CAPACITOR,CERAMIC 0.1MF/25V
CN1	1-568-164-11	s	CONNECTOR,FPC 8P
CN2	1-580-056-21	o	PIN,CONNECTOR 3P
R1	1-216-061-00	s	RESISTOR CHIP 3.3K 1/10W(2012)
R2	1-216-061-00	s	RESISTOR CHIP 3.3K 1/10W(2012)
R3	1-216-061-00	s	RESISTOR CHIP 3.3K 1/10W(2012)
R4	1-216-061-00	s	RESISTOR CHIP 3.3K 1/10W(2012)
R5	1-216-061-00	s	RESISTOR CHIP 3.3K 1/10W(2012)
R6	1-216-061-00	s	RESISTOR CHIP 3.3K 1/10W(2012)
R7	1-216-061-00	s	RESISTOR CHIP 3.3K 1/10W(2012)
R8	1-216-061-00	s	RESISTOR CHIP 3.3K 1/10W(2012)
S1	1-572-487-21	s	SWITCH, SLIDE (1-1-4)
S2	1-571-506-41	s	SWITCH,SLIDE (1-1-3)
S3	1-571-506-41	s	SWITCH,SLIDE (1-1-3)
S4	1-571-275-31	s	SWITCH,SLIDE (1-1-2)

MA-99 BOARD

Ref. No. or Q'ty	Part No.	SP	Description
1pc	A-8323-913-A	o	MOUNTED CIRCUIT BOARD, MA-99
BZ400	1-529-080-11	s	BUZZER,PIEZOELECTRIC
C2	1-126-925-11	s	CAPACITOR,ELECT 470MF/10V
C3	1-164-156-11	s	CAPACITOR,CERAMIC 0.1MF/25V F
C4	1-162-921-11	s	CAPACITOR,CERAMIC 33PF/50V CH
C5	1-135-145-11	s	CAPACITOR TANTALUM 0.47MF/35V
C6	1-104-664-11	s	CAPACITOR, ELECT 47MF/25V
C7	1-126-962-11	s	CAP,ELECT 3.3MF/50V
C8	1-164-156-11	s	CAPACITOR,CERAMIC 0.1MF/25V F
C9	1-163-220-11	s	CAPACITOR, CHIP CERAMIC 3.0PF
C10	1-162-907-11	s	CAPACITOR,CERAMIC 2PF/50V(CK)
C11	1-162-910-11	s	CAPACITOR,CERAMIC 5PF/50V 1608
C12	1-104-664-11	s	CAPACITOR, ELECT 47MF/25V
C13	1-164-156-11	s	CAPACITOR,CERAMIC 0.1MF/25V F
C14	1-162-910-11	s	CAPACITOR,CERAMIC 5PF/50V 1608
C15	1-162-910-11	s	CAPACITOR,CERAMIC 5PF/50V 1608
C16	1-162-923-11	s	CAPACITOR,CERAMIC 47PF/50V CH
C23	1-162-970-11	s	CAPACITOR CERAMIC 0.01MF/25V B
C24	1-162-966-11	s	CAPACITOR,CERAMIC 2200PF/50V B
C25	1-162-970-11	s	CAPACITOR CERAMIC 0.01MF/25V B
C26	1-162-921-11	s	CAPACITOR,CERAMIC 33PF/50V CH
C27	1-126-962-11	s	CAP,ELECT 3.3MF/50V
C28	1-126-964-11	s	CAPACITOR, ELECT 10MF/50V
C29	1-104-664-11	s	CAPACITOR, ELECT 47MF/25V
C30	1-164-156-11	s	CAPACITOR,CERAMIC 0.1MF/25V F
C31	1-104-664-11	s	CAPACITOR, ELECT 47MF/25V
C32	1-162-966-11	s	CAPACITOR,CERAMIC 2200PF/50V B
C33	1-164-156-11	s	CAPACITOR,CERAMIC 0.1MF/25V F
C34	1-164-156-11	s	CAPACITOR,CERAMIC 0.1MF/25V F
C35	1-164-156-11	s	CAPACITOR,CERAMIC 0.1MF/25V F
C36	1-164-156-11	s	CAPACITOR,CERAMIC 0.1MF/25V F
C44	1-104-664-11	s	CAPACITOR, ELECT 47MF/25V
C46	1-164-156-11	s	CAPACITOR,CERAMIC 0.1MF/25V F
C47	1-164-156-11	s	CAPACITOR,CERAMIC 0.1MF/25V F
C56	1-164-156-11	s	CAPACITOR,CERAMIC 0.1MF/25V F
C57	1-164-156-11	s	CAPACITOR,CERAMIC 0.1MF/25V F
C60	1-126-960-11	s	CAPACITOR,ELECT 1MF/50V
C62	1-126-925-11	s	CAPACITOR,ELECT 470MF/10V
C100	1-126-964-11	s	CAPACITOR, ELECT 10MF/50V
C101	1-126-964-11	s	CAPACITOR, ELECT 10MF/50V
C102	1-126-964-11	s	CAPACITOR, ELECT 10MF/50V
C103	1-126-964-11	s	CAPACITOR, ELECT 10MF/50V
C104	1-126-964-11	s	CAPACITOR, ELECT 10MF/50V
C107	1-126-964-11	s	CAPACITOR, ELECT 10MF/50V
C108	1-126-964-11	s	CAPACITOR, ELECT 10MF/50V
C109	1-126-964-11	s	CAPACITOR, ELECT 10MF/50V
C200	1-126-925-11	s	CAPACITOR,ELECT 470MF/10V
C201	1-164-156-11	s	CAPACITOR,CERAMIC 0.1MF/25V F
C202	1-126-941-11	s	CAPACITOR,ELECT 470MF/25V
C203	1-164-156-11	s	CAPACITOR,CERAMIC 0.1MF/25V F
C204	1-126-925-11	s	CAPACITOR,ELECT 470MF/10V
C205	1-164-156-11	s	CAPACITOR,CERAMIC 0.1MF/25V F
C206	1-126-941-11	s	CAPACITOR,ELECT 470MF/25V
C207	1-164-156-11	s	CAPACITOR,CERAMIC 0.1MF/25V F
C208	1-126-925-11	s	CAPACITOR,ELECT 470MF/10V
C209	1-164-156-11	s	CAPACITOR,CERAMIC 0.1MF/25V F
C210	1-104-665-11	s	CAPACITOR, ELECT 100MF/25V

(MA-99 BOARD)

Ref. No. or Q'ty	Part No.	SP	Description
C211	1-164-156-11	s	CAPACITOR,CERAMIC 0.1MF/25V F
C220	1-127-675-11	s	CAPACITOR,CHIP CERAMIC 22MF B
C221	1-126-964-11	s	CAPACITOR, ELECT 10MF/50V
C222	1-162-970-11	s	CAPACITOR CERAMIC 0.01MF/25V B
C223	1-162-966-11	s	CAPACITOR,CERAMIC 2200PF/50V B
C224	1-162-970-11	s	CAPACITOR CERAMIC 0.01MF/25V B
C225	1-164-156-11	s	CAPACITOR,CERAMIC 0.1MF/25V F
C226	1-164-156-11	s	CAPACITOR,CERAMIC 0.1MF/25V F
C235	1-126-962-11	s	CAP,ELECT 3.3MF/50V
C300	1-104-664-11	s	CAPACITOR, ELECT 47MF/25V
C301	1-164-156-11	s	CAPACITOR,CERAMIC 0.1MF/25V F
C302	1-162-970-11	s	CAPACITOR CERAMIC 0.01MF/25V B
C303	1-162-970-11	s	CAPACITOR CERAMIC 0.01MF/25V B
C304	1-162-970-11	s	CAPACITOR CERAMIC 0.01MF/25V B
C305	1-162-970-11	s	CAPACITOR CERAMIC 0.01MF/25V B
C306	1-162-916-11	s	CAPACITOR,CERAMIC 12PF/50V CH
C307	1-162-916-11	s	CAPACITOR,CERAMIC 12PF/50V CH
C310	1-164-156-11	s	CAPACITOR,CERAMIC 0.1MF/25V F
C311	1-164-156-11	s	CAPACITOR,CERAMIC 0.1MF/25V F
C312	1-164-156-11	s	CAPACITOR,CERAMIC 0.1MF/25V F
C313	1-164-156-11	s	CAPACITOR,CERAMIC 0.1MF/25V F
C314	1-162-970-11	s	CAPACITOR CERAMIC 0.01MF/25V B
C315	1-162-970-11	s	CAPACITOR CERAMIC 0.01MF/25V B
C316	1-162-970-11	s	CAPACITOR CERAMIC 0.01MF/25V B
C317	1-162-970-11	s	CAPACITOR CERAMIC 0.01MF/25V B
C318	1-162-970-11	s	CAPACITOR CERAMIC 0.01MF/25V B
C319	1-162-970-11	s	CAPACITOR CERAMIC 0.01MF/25V B
C320	1-162-970-11	s	CAPACITOR CERAMIC 0.01MF/25V B
C321	1-162-970-11	s	CAPACITOR CERAMIC 0.01MF/25V B
C322	1-162-970-11	s	CAPACITOR CERAMIC 0.01MF/25V B
C323	1-164-156-11	s	CAPACITOR,CERAMIC 0.1MF/25V F
C324	1-164-156-11	s	CAPACITOR,CERAMIC 0.1MF/25V F
C325	1-164-156-11	s	CAPACITOR,CERAMIC 0.1MF/25V F
C326	1-164-156-11	s	CAPACITOR,CERAMIC 0.1MF/25V F
C327	1-125-817-11	s	CAPACITOR, CERAMIC 10MF/6.3V
C328	1-164-156-11	s	CAPACITOR,CERAMIC 0.1MF/25V F
C329	1-164-156-11	s	CAPACITOR,CERAMIC 0.1MF/25V F
C330	1-164-156-11	s	CAPACITOR,CERAMIC 0.1MF/25V F
C331	1-164-156-11	s	CAPACITOR,CERAMIC 0.1MF/25V F
C332	1-164-156-11	s	CAPACITOR,CERAMIC 0.1MF/25V F
C333	1-164-156-11	s	CAPACITOR,CERAMIC 0.1MF/25V F
C334	1-164-156-11	s	CAPACITOR,CERAMIC 0.1MF/25V F
C335	1-164-156-11	s	CAPACITOR,CERAMIC 0.1MF/25V F
C336	1-164-156-11	s	CAPACITOR,CERAMIC 0.1MF/25V F
C337	1-164-156-11	s	CAPACITOR,CERAMIC 0.1MF/25V F
C338	1-164-156-11	s	CAPACITOR,CERAMIC 0.1MF/25V F
C339	1-164-156-11	s	CAPACITOR,CERAMIC 0.1MF/25V F
C340	1-164-156-11	s	CAPACITOR,CERAMIC 0.1MF/25V F
C341	1-164-156-11	s	CAPACITOR,CERAMIC 0.1MF/25V F
C350	1-125-817-11	s	CAPACITOR, CERAMIC 10MF/6.3V
C351	1-164-156-11	s	CAPACITOR,CERAMIC 0.1MF/25V F
C352	1-164-227-11	s	CAPACITOR,CERAMIC 0.022MF/25V
C360	1-164-156-11	s	CAPACITOR,CERAMIC 0.1MF/25V F
C361	1-125-817-11	s	CAPACITOR, CERAMIC 10MF/6.3V
C362	1-162-970-11	s	CAPACITOR CERAMIC 0.01MF/25V B
C401	1-104-664-11	s	CAPACITOR, ELECT 47MF/25V
C403	1-125-817-11	s	CAPACITOR, CERAMIC 10MF/6.3V
C404	1-164-156-11	s	CAPACITOR,CERAMIC 0.1MF/25V F
C405	1-164-227-11	s	CAPACITOR,CERAMIC 0.022MF/25V

(MA-99 BOARD)

Ref. No. or Q'ty	Part No.	SP	Description
C406	1-164-156-11	s	CAPACITOR,CERAMIC 0.1MF/25V F
C407	1-104-664-11	s	CAPACITOR, ELECT 47MF/25V
C409	1-125-817-11	s	CAPACITOR, CERAMIC 10MF/6.3V
C431	1-162-970-11	s	CAPACITOR CERAMIC 0.01MF/25V B
C432	1-164-156-11	s	CAPACITOR,CERAMIC 0.1MF/25V F
C433	1-164-156-11	s	CAPACITOR,CERAMIC 0.1MF/25V F
C500	1-164-156-11	s	CAPACITOR,CERAMIC 0.1MF/25V F
C501	1-164-156-11	s	CAPACITOR,CERAMIC 0.1MF/25V F
C502	1-164-156-11	s	CAPACITOR,CERAMIC 0.1MF/25V F
C503	1-164-156-11	s	CAPACITOR,CERAMIC 0.1MF/25V F
C504	1-164-156-11	s	CAPACITOR,CERAMIC 0.1MF/25V F
C505	1-125-817-11	s	CAPACITOR, CERAMIC 10MF/6.3V
C506	1-164-156-11	s	CAPACITOR,CERAMIC 0.1MF/25V F
C507	1-164-156-11	s	CAPACITOR,CERAMIC 0.1MF/25V F
C508	1-164-156-11	s	CAPACITOR,CERAMIC 0.1MF/25V F
C509	1-164-156-11	s	CAPACITOR,CERAMIC 0.1MF/25V F
C510	1-164-156-11	s	CAPACITOR,CERAMIC 0.1MF/25V F
C511	1-164-156-11	s	CAPACITOR,CERAMIC 0.1MF/25V F
C512	1-164-156-11	s	CAPACITOR,CERAMIC 0.1MF/25V F
C513	1-164-156-11	s	CAPACITOR,CERAMIC 0.1MF/25V F
C514	1-125-817-11	s	CAPACITOR, CERAMIC 10MF/6.3V
C515	1-164-156-11	s	CAPACITOR,CERAMIC 0.1MF/25V F
C516	1-164-156-11	s	CAPACITOR,CERAMIC 0.1MF/25V F
C517	1-164-156-11	s	CAPACITOR,CERAMIC 0.1MF/25V F
C518	1-164-156-11	s	CAPACITOR,CERAMIC 0.1MF/25V F
C519	1-125-817-11	s	CAPACITOR, CERAMIC 10MF/6.3V
C520	1-164-156-11	s	CAPACITOR,CERAMIC 0.1MF/25V F
C521	1-164-156-11	s	CAPACITOR,CERAMIC 0.1MF/25V F
C522	1-162-921-11	s	CAPACITOR,CERAMIC 33PF/50V CH
C523	1-164-156-11	s	CAPACITOR,CERAMIC 0.1MF/25V F
C524	1-164-156-11	s	CAPACITOR,CERAMIC 0.1MF/25V F
C525	1-164-156-11	s	CAPACITOR,CERAMIC 0.1MF/25V F
C526	1-164-156-11	s	CAPACITOR,CERAMIC 0.1MF/25V F
C527	1-164-156-11	s	CAPACITOR,CERAMIC 0.1MF/25V F
C528	1-164-156-11	s	CAPACITOR,CERAMIC 0.1MF/25V F
C529	1-125-817-11	s	CAPACITOR, CERAMIC 10MF/6.3V
C530	1-164-156-11	s	CAPACITOR,CERAMIC 0.1MF/25V F
C531	1-164-156-11	s	CAPACITOR,CERAMIC 0.1MF/25V F
C532	1-164-156-11	s	CAPACITOR,CERAMIC 0.1MF/25V F
C533	1-164-156-11	s	CAPACITOR,CERAMIC 0.1MF/25V F
C535	1-162-919-11	s	CAPACITOR,CERAMIC 22PF/50V CH
C536	1-162-919-11	s	CAPACITOR,CERAMIC 22PF/50V CH
C537	1-164-156-11	s	CAPACITOR,CERAMIC 0.1MF/25V F
C539	1-125-817-11	s	CAPACITOR, CERAMIC 10MF/6.3V
C540	1-125-817-11	s	CAPACITOR, CERAMIC 10MF/6.3V
C541	1-125-817-11	s	CAPACITOR, CERAMIC 10MF/6.3V
C542	1-164-156-11	s	CAPACITOR,CERAMIC 0.1MF/25V F
C543	1-164-156-11	s	CAPACITOR,CERAMIC 0.1MF/25V F
C544	1-164-156-11	s	CAPACITOR,CERAMIC 0.1MF/25V F
C545	1-162-970-11	s	CAPACITOR CERAMIC 0.01MF/25V B
C548	1-164-156-11	s	CAPACITOR,CERAMIC 0.1MF/25V F
CN1	1-695-408-11	s	SOCKET, CONNECTOR FPC (11P)
CN2	1-506-472-11	s	PIN,CONNECTOR 7P
CN3	1-751-022-11	s	SOCKET, CONNECTOR 8P (FPC)
CN5	1-564-005-11	o	PIN, CONNECTOR 6P
CN6	1-770-469-21	o	PIN, CONNECTOR (PC BOARD) 2P
CN7	1-564-002-11	s	PIN, CONNECTOR 3P
CN8	1-564-005-11	o	PIN, CONNECTOR 6P

(MA-99 BOARD)

Ref. No. or Q'ty	Part No.	SP	Description
CN9	1-565-473-11	o	HOUSING, CONNECTOR 30P
CN10	1-691-431-11	s	CONNECTOR ASSY, BNC
CN11	1-564-004-11	o	PIN, CONNECTOR 5P
CN13	1-764-781-11	o	SOCKET, CONNECTOR 26P
CN14	1-569-536-11	s	SOCKET, CONNECTOR 7P
D2	8-719-820-41	s	DIODE 1SS302
D5	8-719-820-41	s	DIODE 1SS302
D300	8-719-820-41	s	DIODE 1SS302
D301	8-719-820-41	s	DIODE 1SS302
D302	8-719-820-41	s	DIODE 1SS302
D303	8-719-820-41	s	DIODE 1SS302
D304	8-719-820-41	s	DIODE 1SS302
D305	8-719-820-41	s	DIODE 1SS302
D306	8-719-820-41	s	DIODE 1SS302
D307	8-719-820-41	s	DIODE 1SS302
D308	8-719-820-41	s	DIODE 1SS302
D309	8-719-820-41	s	DIODE 1SS302
D310	8-719-820-41	s	DIODE 1SS302
D311	8-719-820-41	s	DIODE 1SS302
D312	8-719-820-41	s	DIODE 1SS302
D313	8-719-820-41	s	DIODE 1SS302
D314	8-719-820-41	s	DIODE 1SS302
D315	8-719-820-41	s	DIODE 1SS302
D316	8-719-820-41	s	DIODE 1SS302
D317	8-719-820-41	s	DIODE 1SS302
D318	8-719-820-41	s	DIODE 1SS302
D319	8-719-820-41	s	DIODE 1SS302
D320	8-719-820-41	s	DIODE 1SS302
D321	8-719-820-41	s	DIODE 1SS302
D322	8-719-820-41	s	DIODE 1SS302
D323	8-719-820-41	s	DIODE 1SS302
D324	8-719-820-41	s	DIODE 1SS302
D325	8-719-820-41	s	DIODE 1SS302
D400	8-719-200-02	s	DIODE 10E2 (RECTI)
D401	8-719-104-34	s	DIODE 1S2836
D402	8-719-104-34	s	DIODE 1S2836
D403	8-719-104-34	s	DIODE 1S2836
D404	8-719-104-34	s	DIODE 1S2836
D405	8-719-820-41	s	DIODE 1SS302
D406	8-719-104-34	s	DIODE 1S2836
D407	8-719-104-34	s	DIODE 1S2836
D408	8-719-820-41	s	DIODE 1SS302
D600	8-719-820-41	s	DIODE 1SS302
F400	△ 1-532-777-51	s	FUSE MICRO 1.25A/125V
FB200	1-410-397-21	s	FERRITE BEAD INDUCTOR
FB201	1-410-397-21	s	FERRITE BEAD INDUCTOR
FB202	1-410-397-21	s	FERRITE BEAD INDUCTOR
FB203	1-410-397-21	s	FERRITE BEAD INDUCTOR
FB204	1-410-397-21	s	FERRITE BEAD INDUCTOR
FB205	1-410-397-21	s	FERRITE BEAD INDUCTOR
FL1	1-760-578-11	s	FILTER, CERAMIC
FL2	1-579-348-11	s	FILTER, CERAMIC
FL3	1-414-760-21	s	INDUCTOR, MICRO (CHIP TYPE)
FL4	1-414-760-21	s	INDUCTOR, MICRO (CHIP TYPE)
IC1	8-759-710-07	s	IC NJM2234M
IC2	8-759-304-10	s	IC HA11465A
IC4	8-759-983-69	s	IC LM358PS

(MA-99 BOARD)

Ref. No. or Q'ty	Part No.	SP	Description
IC5	8-759-009-07	s	IC MC14053BF
IC6	8-759-196-69	s	IC BA7655AF-E2
IC200	8-759-473-67	s	IC PQ3RF33
IC201	8-759-701-79	s	IC NJM7812FA
IC300	8-759-278-46	s	IC PST600DMT (T1)
IC301	8-759-925-80	s	IC SN74HC14ANS
IC302	8-759-270-25	s	IC SN74HC251ANSR
IC303	8-759-270-25	s	IC SN74HC251ANSR
IC304	8-759-660-62	s	IC HD6473657F-UP895-VER1.0
IC305	8-759-672-80	s	IC M24C02-MN6T(A)
IC400	8-759-600-24	s	IC M54543L
IC401	8-759-983-69	s	IC LM358PS
IC430	8-759-058-54	s	IC TC7S00FU-TE85R
IC431	8-759-257-96	s	IC TC7S14FU (TE85R)
IC500	8-759-528-24	s	IC MB40C568HPF-ER
IC501	8-759-644-67	s	IC CXD9113AR
IC502	8-752-334-64	s	IC CXD1171M
IC503	8-759-650-92	s	IC MB81F64842D-102FN
IC504	8-759-359-12	s	IC DS1000Z-100
IC505	8-759-287-50	s	IC CXD8932Q
IC506	8-759-524-21	s	IC TC74VHC174FT(EL)
J300	1-507-967-11	s	JACK
L2	1-410-369-11	s	CHIP INDUCTOR 1.0UH (3225)
L3	1-410-369-11	s	CHIP INDUCTOR 1.0UH (3225)
L5	1-410-391-11	s	CHIP INDUCTOR 68UH (3225)
L6	1-410-391-11	s	CHIP INDUCTOR 68UH (3225)
L7	1-408-765-21	s	CHIP INDUCTOR 1UH (4532)
L101	1-408-765-21	s	CHIP INDUCTOR 1UH (4532)
L302	1-408-775-21	s	CHIP INDUCTOR 6.8UH (4532)
L303	1-408-775-21	s	CHIP INDUCTOR 6.8UH (4532)
L304	1-408-777-00	s	CHIP INDUCTOR 10UH (4532)
L305	1-408-765-21	s	CHIP INDUCTOR 1UH (4532)
L306	1-408-765-21	s	CHIP INDUCTOR 1UH (4532)
L307	1-408-765-21	s	CHIP INDUCTOR 1UH (4532)
L308	1-408-765-21	s	CHIP INDUCTOR 1UH (4532)
L309	1-408-765-21	s	CHIP INDUCTOR 1UH (4532)
L310	1-408-765-21	s	CHIP INDUCTOR 1UH (4532)
L311	1-408-765-21	s	CHIP INDUCTOR 1UH (4532)
L400	1-408-765-21	s	CHIP INDUCTOR 1UH (4532)
L403	1-408-765-21	s	CHIP INDUCTOR 1UH (4532)
L500	1-408-769-41	s	CHIP INDUCTOR 2.2UH
L501	1-408-769-41	s	CHIP INDUCTOR 2.2UH
Q1	8-729-901-00	s	TRANSISTOR DTC124EK
Q2	8-729-120-28	s	TRANSISTOR 2SC1623-L5L6
Q5	8-729-216-22	s	TRANSISTOR 2SA1162-G
Q6	8-729-402-81	s	TRANSISTOR XN4501
Q7	8-729-402-84	s	TRANSISTOR XN4601
Q8	8-729-120-28	s	TRANSISTOR 2SC1623-L5L6
Q11	8-729-120-28	s	TRANSISTOR 2SC1623-L5L6
Q12	8-729-402-84	s	TRANSISTOR XN4601
Q13	8-729-035-96	s	TRANSISTOR XN4402-(TX)
Q14	8-729-402-81	s	TRANSISTOR XN4501
Q16	8-729-402-84	s	TRANSISTOR XN4601
Q17	8-729-402-84	s	TRANSISTOR XN4601
Q21	8-729-402-81	s	TRANSISTOR XN4501
Q40	8-729-120-28	s	TRANSISTOR 2SC1623-L5L6
Q41	8-729-901-00	s	TRANSISTOR DTC124EK

(MA-99 BOARD)

Ref. No. or Q'ty	Part No.	SP	Description
Q50	8-729-402-81	s	TRANSISTOR XN4501
Q51	8-729-216-22	s	TRANSISTOR 2SA1162-G
Q52	8-729-216-22	s	TRANSISTOR 2SA1162-G
Q54	8-729-216-22	s	TRANSISTOR 2SA1162-G
Q173	8-729-035-96	s	TRANSISTOR XN4402-(TX)
Q174	8-729-035-96	s	TRANSISTOR XN4402-(TX)
Q200	8-729-140-75	s	TRANSISTOR 2SD999-CLOCK
Q220	8-729-402-81	s	TRANSISTOR XN4501
Q221	8-729-120-28	s	TRANSISTOR 2SC1623-L5L6
Q300	8-729-901-00	s	TRANSISTOR DTC124EK
Q301	8-729-901-00	s	TRANSISTOR DTC124EK
Q400	8-729-140-75	s	TRANSISTOR 2SD999-CLOCK
Q401	8-729-120-28	s	TRANSISTOR 2SC1623-L5L6
Q402	8-729-140-75	s	TRANSISTOR 2SD999-CLOCK
Q403	8-729-017-80	s	TRANSISTOR 2SD992-Z
Q404	8-729-017-80	s	TRANSISTOR 2SD992-Z
Q405	8-729-017-80	s	TRANSISTOR 2SD992-Z
Q406	8-729-017-80	s	TRANSISTOR 2SD992-Z
Q407	8-729-017-80	s	TRANSISTOR 2SD992-Z
R1	1-216-811-11	s	RESISTOR, CHIP 150 1/16W 1608
R2	1-216-811-11	s	RESISTOR, CHIP 150 1/16W 1608
R4	1-216-829-11	s	RESISTOR, CHIP 4.7K 1/16W 1608
R5	1-216-831-11	s	RESISTOR,CHIP 6.8K 1/16W(1608)
R6	1-216-834-11	s	RESISTOR,CHIP 12K 1/16W 1608
R7	1-216-809-11	s	RESISTOR,CHIP 100 1/16W 1608
R8	1-216-833-11	s	RESISTOR,CHIP 10K 1/16W 1608
R9	1-216-821-11	s	RESISTOR,CHIP 1.0K 1/16W(1608)
R18	1-216-809-11	s	RESISTOR,CHIP 100 1/16W 1608
R19	1-216-803-11	s	RESISTOR,CHIP 33 1/16W 1608
R21	1-216-821-11	s	RESISTOR,CHIP 1.0K 1/16W(1608)
R22	1-216-809-11	s	RESISTOR,CHIP 100 1/16W 1608
R23	1-216-844-11	s	RESISTOR,CHIP 82K 1/16W 1608
R24	1-216-819-11	s	RESISTOR,CHIP 680 1/16W 1608
R25	1-216-829-11	s	RESISTOR, CHIP 4.7K 1/16W 1608
R26	1-216-833-11	s	RESISTOR,CHIP 10K 1/16W 1608
R30	1-216-812-11	s	RESISTOR,CHIP 180 1/16W 1608
R31	1-216-825-11	s	RESISTOR,CHIP 2.2K 1/16W 1608
R32	1-216-828-11	s	RESISTOR, CHIP 3.9K 1/16W 1608
R33	1-216-812-11	s	RESISTOR,CHIP 180 1/16W 1608
R34	1-216-817-11	s	RESISTOR,CHIP 470 1/16W 1608
R35	1-216-827-11	s	RESISTOR, CHIP 3.3K 1/16W 1608
R36	1-216-821-11	s	RESISTOR,CHIP 1.0K 1/16W(1608)
R37	1-216-803-11	s	RESISTOR,CHIP 33 1/16W 1608
R38	1-216-825-11	s	RESISTOR,CHIP 2.2K 1/16W 1608
R39	1-216-819-11	s	RESISTOR,CHIP 680 1/16W 1608
R40	1-216-815-11	s	RESISTOR,CHIP 330 1/16W 1608
R41	1-216-811-11	s	RESISTOR, CHIP 150 1/16W 1608
R42	1-216-811-11	s	RESISTOR, CHIP 150 1/16W 1608
R43	1-216-833-11	s	RESISTOR,CHIP 10K 1/16W 1608
R53	1-216-803-11	s	RESISTOR,CHIP 33 1/16W 1608
R56	1-216-821-11	s	RESISTOR,CHIP 1.0K 1/16W(1608)
R57	1-216-821-11	s	RESISTOR,CHIP 1.0K 1/16W(1608)
R58	1-216-825-11	s	RESISTOR,CHIP 2.2K 1/16W 1608
R59	1-216-833-11	s	RESISTOR,CHIP 10K 1/16W 1608
R60	1-216-856-11	s	RESISTOR, CHIP 820K 1/16W 1608
R61	1-218-871-11	s	RESISTOR,CHIP 10K 1/16W (1608)
R62	1-218-871-11	s	RESISTOR,CHIP 10K 1/16W (1608)
R63	1-216-803-11	s	RESISTOR,CHIP 33 1/16W 1608
R64	1-216-821-11	s	RESISTOR,CHIP 1.0K 1/16W(1608)

(MA-99 BOARD)

Ref. No. or Q'ty	Part No.	SP	Description
R65	1-216-829-11	s	RESISTOR, CHIP 4.7K 1/16W 1608
R66	1-216-825-11	s	RESISTOR,CHIP 2.2K 1/16W 1608
R67	1-216-837-11	s	RESISTOR,CHIP 22K 1/16W 1608
R68	1-216-833-11	s	RESISTOR,CHIP 10K 1/16W 1608
R69	1-216-826-11	s	RESISTOR,CHIP 2.7K 1/16W 1608
R70	1-216-833-11	s	RESISTOR,CHIP 10K 1/16W 1608
R71	1-218-879-11	s	RESISTOR,CHIP 22K 1/16W (1608)
R72	1-216-830-11	s	RESISTOR,CHIP 5.6K 1/16W 1608
R74	1-216-845-11	s	RESISTOR,CHIP 100K 1/16W(1608)
R75	1-216-833-11	s	RESISTOR,CHIP 10K 1/16W 1608
R76	1-216-831-11	s	RESISTOR,CHIP 6.8K 1/16W(1608)
R97	1-216-813-11	s	RESISTOR, CHIP 220 1/16W 1608
R98	1-216-813-11	s	RESISTOR, CHIP 220 1/16W 1608
R101	1-216-834-11	s	RESISTOR,CHIP 12K 1/16W 1608
R103	1-216-824-11	s	RESISTOR, CHIP 1.8K 1/16W 1608
R104	1-216-843-11	s	RESISTOR,CHIP 68K 1/16W (1608)
R123	1-218-845-11	s	RESISTOR,CHIP 820 1/16W (1608)
R124	1-218-847-11	s	RESISTOR, CHIP 1K 1/16W (1608)
R125	1-218-833-11	s	RESISTOR,CHIP 270 1/16W (1608)
R127	1-216-864-11	s	RESISTOR,CHIP 0 1/16W (1608)
R128	1-216-864-11	s	RESISTOR,CHIP 0 1/16W (1608)
R130	1-216-824-11	s	RESISTOR, CHIP 1.8K 1/16W 1608
R131	1-216-817-11	s	RESISTOR,CHIP 470 1/16W 1608
R132	1-216-818-11	s	RESISTOR, CHIP 560 1/16W 1608
R133	1-218-861-11	s	RESISTOR,CHIP 3.9K 1/16W(1608)
R150	1-216-833-11	s	RESISTOR,CHIP 10K 1/16W 1608
R155	1-216-832-11	s	RESISTOR,CHIP 8.2K 1/16W 1608
R156	1-216-825-11	s	RESISTOR,CHIP 2.2K 1/16W 1608
R157	1-216-821-11	s	RESISTOR,CHIP 1.0K 1/16W(1608)
R158	1-216-815-11	s	RESISTOR,CHIP 330 1/16W 1608
R159	1-216-823-11	s	RESISTOR, CHIP 1.5K 1/16W
R160	1-216-821-11	s	RESISTOR,CHIP 1.0K 1/16W(1608)
R161	1-216-830-11	s	RESISTOR,CHIP 5.6K 1/16W 1608
R162	1-216-825-11	s	RESISTOR,CHIP 2.2K 1/16W 1608
R163	1-216-821-11	s	RESISTOR,CHIP 1.0K 1/16W(1608)
R164	1-216-821-11	s	RESISTOR,CHIP 1.0K 1/16W(1608)
R167	1-216-815-11	s	RESISTOR,CHIP 330 1/16W 1608
R168	1-216-821-11	s	RESISTOR,CHIP 1.0K 1/16W(1608)
R173	1-216-803-11	s	RESISTOR,CHIP 33 1/16W 1608
R174	1-216-821-11	s	RESISTOR,CHIP 1.0K 1/16W(1608)
R175	1-216-821-11	s	RESISTOR,CHIP 1.0K 1/16W(1608)
R176	1-216-827-11	s	RESISTOR, CHIP 3.3K 1/16W 1608
R177	1-216-295-91	s	RESISTOR, CHIP 0 (1/10W)
R180	1-414-760-21	s	INDUCTOR, MICRO (CHIP TYPE)
R181	1-216-864-11	s	RESISTOR,CHIP 0 1/16W (1608)
R200	1-216-343-00	s	RESISTOR,METAL FILM 0.33/1W
R220	1-216-821-11	s	RESISTOR,CHIP 1.0K 1/16W(1608)
R221	1-216-821-11	s	RESISTOR,CHIP 1.0K 1/16W(1608)
R222	1-216-856-11	s	RESISTOR, CHIP 820K 1/16W 1608
R223	1-218-871-11	s	RESISTOR,CHIP 10K 1/16W (1608)
R224	1-216-833-11	s	RESISTOR,CHIP 10K 1/16W 1608
R225	1-216-825-11	s	RESISTOR,CHIP 2.2K 1/16W 1608
R226	1-216-821-11	s	RESISTOR,CHIP 1.0K 1/16W(1608)
R227	1-216-821-11	s	RESISTOR,CHIP 1.0K 1/16W(1608)
R228	1-216-803-11	s	RESISTOR,CHIP 33 1/16W 1608
R229	1-218-871-11	s	RESISTOR,CHIP 10K 1/16W (1608)
R230	1-216-821-11	s	RESISTOR,CHIP 1.0K 1/16W(1608)
R231	1-216-821-11	s	RESISTOR,CHIP 1.0K 1/16W(1608)
R232	1-216-819-11	s	RESISTOR,CHIP 680 1/16W 1608

(MA-99 BOARD)

Ref. No. or Q'ty	Part No.	SP	Description
R233	1-216-803-11	s	RESISTOR,CHIP 33 1/16W 1608
R234	1-216-819-11	s	RESISTOR,CHIP 680 1/16W 1608
R235	1-216-822-11	s	RESISTOR, CHIP 1.2K 1/16W 1608
R236	1-216-803-11	s	RESISTOR,CHIP 33 1/16W 1608
R237	1-216-821-11	s	RESISTOR,CHIP 1.0K 1/16W(1608)
R238	1-216-826-11	s	RESISTOR,CHIP 2.7K 1/16W 1608
R239	1-216-803-11	s	RESISTOR,CHIP 33 1/16W 1608
R240	1-216-821-11	s	RESISTOR,CHIP 1.0K 1/16W(1608)
R300	1-216-833-11	s	RESISTOR,CHIP 10K 1/16W 1608
R302	1-216-815-11	s	RESISTOR,CHIP 330 1/16W 1608
R303	1-216-833-11	s	RESISTOR,CHIP 10K 1/16W 1608
R304	1-216-815-11	s	RESISTOR,CHIP 330 1/16W 1608
R305	1-216-833-11	s	RESISTOR,CHIP 10K 1/16W 1608
R306	1-216-833-11	s	RESISTOR,CHIP 10K 1/16W 1608
R307	1-216-833-11	s	RESISTOR,CHIP 10K 1/16W 1608
R308	1-216-833-11	s	RESISTOR,CHIP 10K 1/16W 1608
R310	1-216-817-11	s	RESISTOR,CHIP 470 1/16W 1608
R311	1-216-824-11	s	RESISTOR, CHIP 1.8K 1/16W 1608
R312	1-216-857-11	s	RESISTOR, CHIP 1.0M 1/16W 1608
R313	1-216-827-11	s	RESISTOR, CHIP 3.3K 1/16W 1608
R314	1-216-827-11	s	RESISTOR, CHIP 3.3K 1/16W 1608
R315	1-216-827-11	s	RESISTOR, CHIP 3.3K 1/16W 1608
R316	1-216-827-11	s	RESISTOR, CHIP 3.3K 1/16W 1608
R317	1-216-827-11	s	RESISTOR, CHIP 3.3K 1/16W 1608
R318	1-216-827-11	s	RESISTOR, CHIP 3.3K 1/16W 1608
R319	1-216-827-11	s	RESISTOR, CHIP 3.3K 1/16W 1608
R320	1-216-833-11	s	RESISTOR,CHIP 10K 1/16W 1608
R321	1-216-833-11	s	RESISTOR,CHIP 10K 1/16W 1608
R322	1-216-833-11	s	RESISTOR,CHIP 10K 1/16W 1608
R323	1-216-833-11	s	RESISTOR,CHIP 10K 1/16W 1608
R324	1-216-833-11	s	RESISTOR,CHIP 10K 1/16W 1608
R325	1-216-833-11	s	RESISTOR,CHIP 10K 1/16W 1608
R326	1-216-833-11	s	RESISTOR,CHIP 10K 1/16W 1608
R329	1-216-833-11	s	RESISTOR,CHIP 10K 1/16W 1608
R330	1-216-833-11	s	RESISTOR,CHIP 10K 1/16W 1608
R332	1-216-833-11	s	RESISTOR,CHIP 10K 1/16W 1608
R334	1-216-833-11	s	RESISTOR,CHIP 10K 1/16W 1608
R335	1-216-833-11	s	RESISTOR,CHIP 10K 1/16W 1608
R336	1-216-833-11	s	RESISTOR,CHIP 10K 1/16W 1608
R337	1-216-833-11	s	RESISTOR,CHIP 10K 1/16W 1608
R338	1-216-833-11	s	RESISTOR,CHIP 10K 1/16W 1608
R339	1-216-833-11	s	RESISTOR,CHIP 10K 1/16W 1608
R340	1-216-833-11	s	RESISTOR,CHIP 10K 1/16W 1608
R341	1-216-833-11	s	RESISTOR,CHIP 10K 1/16W 1608
R342	1-216-833-11	s	RESISTOR,CHIP 10K 1/16W 1608
R343	1-216-833-11	s	RESISTOR,CHIP 10K 1/16W 1608
R354	1-216-833-11	s	RESISTOR,CHIP 10K 1/16W 1608
R355	1-216-833-11	s	RESISTOR,CHIP 10K 1/16W 1608
R356	1-216-833-11	s	RESISTOR,CHIP 10K 1/16W 1608
R357	1-216-833-11	s	RESISTOR,CHIP 10K 1/16W 1608
R362	1-216-809-11	s	RESISTOR,CHIP 100 1/16W 1608
R363	1-216-809-11	s	RESISTOR,CHIP 100 1/16W 1608
R364	1-216-809-11	s	RESISTOR,CHIP 100 1/16W 1608
R365	1-216-809-11	s	RESISTOR,CHIP 100 1/16W 1608
R366	1-216-809-11	s	RESISTOR,CHIP 100 1/16W 1608
R367	1-216-827-11	s	RESISTOR, CHIP 3.3K 1/16W 1608
R368	1-216-813-11	s	RESISTOR, CHIP 220 1/16W 1608
R369	1-414-813-11	s	MICRO INDUCTOR(CHIP TYPE) 2012
R370	1-216-809-11	s	RESISTOR,CHIP 100 1/16W 1608

(MA-99 BOARD)

Ref. No. or Q'ty	Part No.	SP	Description
R371	1-216-827-11	s	RESISTOR, CHIP 3.3K 1/16W 1608
R372	1-414-813-11	s	MICRO INDUCTOR(CHIP TYPE) 2012
R373	1-216-813-11	s	RESISTOR, CHIP 220 1/16W 1608
R374	1-216-813-11	s	RESISTOR, CHIP 220 1/16W 1608
R375	1-216-813-11	s	RESISTOR, CHIP 220 1/16W 1608
R376	1-216-813-11	s	RESISTOR, CHIP 220 1/16W 1608
R377	1-216-813-11	s	RESISTOR, CHIP 220 1/16W 1608
R378	1-216-809-11	s	RESISTOR,CHIP 100 1/16W 1608
R379	1-216-809-11	s	RESISTOR,CHIP 100 1/16W 1608
R380	1-216-809-11	s	RESISTOR,CHIP 100 1/16W 1608
R381	1-216-809-11	s	RESISTOR,CHIP 100 1/16W 1608
R382	1-216-809-11	s	RESISTOR,CHIP 100 1/16W 1608
R383	1-216-809-11	s	RESISTOR,CHIP 100 1/16W 1608
R384	1-216-809-11	s	RESISTOR,CHIP 100 1/16W 1608
R385	1-216-809-11	s	RESISTOR,CHIP 100 1/16W 1608
R386	1-216-821-11	s	RESISTOR,CHIP 1.0K 1/16W(1608)
R387	1-216-821-11	s	RESISTOR,CHIP 1.0K 1/16W(1608)
R388	1-216-821-11	s	RESISTOR,CHIP 1.0K 1/16W(1608)
R389	1-216-821-11	s	RESISTOR,CHIP 1.0K 1/16W(1608)
R390	1-216-821-11	s	RESISTOR,CHIP 1.0K 1/16W(1608)
R391	1-216-821-11	s	RESISTOR,CHIP 1.0K 1/16W(1608)
R392	1-216-821-11	s	RESISTOR,CHIP 1.0K 1/16W(1608)
R393	1-216-821-11	s	RESISTOR,CHIP 1.0K 1/16W(1608)
R394	1-216-821-11	s	RESISTOR,CHIP 1.0K 1/16W(1608)
R395	1-216-821-11	s	RESISTOR,CHIP 1.0K 1/16W(1608)
R396	1-216-821-11	s	RESISTOR,CHIP 1.0K 1/16W(1608)
R397	1-216-809-11	s	RESISTOR,CHIP 100 1/16W 1608
R398	1-216-815-11	s	RESISTOR,CHIP 330 1/16W 1608
R400	1-216-818-11	s	RESISTOR, CHIP 560 1/16W 1608
R401	1-216-818-11	s	RESISTOR, CHIP 560 1/16W 1608
R402	1-216-818-11	s	RESISTOR, CHIP 560 1/16W 1608
R403	1-216-818-11	s	RESISTOR, CHIP 560 1/16W 1608
R404	1-216-825-11	s	RESISTOR,CHIP 2.2K 1/16W 1608
R405	1-216-821-11	s	RESISTOR,CHIP 1.0K 1/16W(1608)
R406	1-216-821-11	s	RESISTOR,CHIP 1.0K 1/16W(1608)
R407	1-220-238-11	s	RESISTOR CHIP 10 1/4W (3225)
R408	1-220-238-11	s	RESISTOR CHIP 10 1/4W (3225)
R409	1-216-821-11	s	RESISTOR,CHIP 1.0K 1/16W(1608)
R410	1-216-833-11	s	RESISTOR,CHIP 10K 1/16W 1608
R411	1-216-824-11	s	RESISTOR, CHIP 1.8K 1/16W 1608
R412	1-216-821-11	s	RESISTOR,CHIP 1.0K 1/16W(1608)
R413	1-216-817-11	s	RESISTOR,CHIP 470 1/16W 1608
R414	1-216-813-11	s	RESISTOR, CHIP 220 1/16W 1608
R415	1-216-813-11	s	RESISTOR, CHIP 220 1/16W 1608
R416	1-216-813-11	s	RESISTOR, CHIP 220 1/16W 1608
R417	1-216-813-11	s	RESISTOR, CHIP 220 1/16W 1608
R418	1-216-809-11	s	RESISTOR,CHIP 100 1/16W 1608
R419	1-216-809-11	s	RESISTOR,CHIP 100 1/16W 1608
R420	1-218-861-11	s	RESISTOR,CHIP 3.9K 1/16W(1608)
R421	1-218-875-11	s	RESISTOR,CHIP 15K 1/16W (1608)
R423	1-218-895-11	s	RESISTOR,CHIP 100K 1/16W(1608)
R424	1-218-899-11	s	RESISTOR,CHIP 150K 1/16W(1608)
R425	1-218-879-11	s	RESISTOR,CHIP 22K 1/16W (1608)
R426	1-216-864-11	s	RESISTOR,CHIP 0 1/16W (1608)
R427	1-216-864-11	s	RESISTOR,CHIP 0 1/16W (1608)
R430	1-216-815-11	s	RESISTOR,CHIP 330 1/16W 1608
R431	1-216-837-11	s	RESISTOR,CHIP 22K 1/16W 1608
R432	1-216-827-11	s	RESISTOR, CHIP 3.3K 1/16W 1608
R501	1-216-813-11	s	RESISTOR, CHIP 220 1/16W 1608

(MA-99 BOARD)

Ref. No. or Q'ty	Part No.	SP	Description
R502	1-216-813-11	s	RESISTOR, CHIP 220 1/16W 1608
R503	1-216-813-11	s	RESISTOR, CHIP 220 1/16W 1608
R504	1-216-813-11	s	RESISTOR, CHIP 220 1/16W 1608
R505	1-216-813-11	s	RESISTOR, CHIP 220 1/16W 1608
R506	1-216-813-11	s	RESISTOR, CHIP 220 1/16W 1608
R507	1-216-813-11	s	RESISTOR, CHIP 220 1/16W 1608
R508	1-216-813-11	s	RESISTOR, CHIP 220 1/16W 1608
R509	1-216-813-11	s	RESISTOR, CHIP 220 1/16W 1608
R510	1-216-813-11	s	RESISTOR, CHIP 220 1/16W 1608
R511	1-216-813-11	s	RESISTOR, CHIP 220 1/16W 1608
R512	1-216-813-11	s	RESISTOR, CHIP 220 1/16W 1608
R513	1-216-813-11	s	RESISTOR, CHIP 220 1/16W 1608
R514	1-216-813-11	s	RESISTOR, CHIP 220 1/16W 1608
R515	1-216-813-11	s	RESISTOR, CHIP 220 1/16W 1608
R516	1-216-813-11	s	RESISTOR, CHIP 220 1/16W 1608
R517	1-216-813-11	s	RESISTOR, CHIP 220 1/16W 1608
R518	1-216-813-11	s	RESISTOR, CHIP 220 1/16W 1608
R519	1-216-813-11	s	RESISTOR, CHIP 220 1/16W 1608
R520	1-216-809-11	s	RESISTOR,CHIP 100 1/16W 1608
R521	1-216-813-11	s	RESISTOR, CHIP 220 1/16W 1608
R522	1-216-813-11	s	RESISTOR, CHIP 220 1/16W 1608
R524	1-216-813-11	s	RESISTOR, CHIP 220 1/16W 1608
R525	1-216-813-11	s	RESISTOR, CHIP 220 1/16W 1608
R526	1-216-813-11	s	RESISTOR, CHIP 220 1/16W 1608
R527	1-216-813-11	s	RESISTOR, CHIP 220 1/16W 1608
R528	1-216-813-11	s	RESISTOR, CHIP 220 1/16W 1608
R529	1-216-813-11	s	RESISTOR, CHIP 220 1/16W 1608
R530	1-216-813-11	s	RESISTOR, CHIP 220 1/16W 1608
R531	1-216-813-11	s	RESISTOR, CHIP 220 1/16W 1608
R532	1-216-813-11	s	RESISTOR, CHIP 220 1/16W 1608
R533	1-216-813-11	s	RESISTOR, CHIP 220 1/16W 1608
R534	1-216-809-11	s	RESISTOR,CHIP 100 1/16W 1608
R535	1-216-813-11	s	RESISTOR, CHIP 220 1/16W 1608
R536	1-216-813-11	s	RESISTOR, CHIP 220 1/16W 1608
R537	1-216-813-11	s	RESISTOR, CHIP 220 1/16W 1608
R538	1-218-843-11	s	RESISTOR,CHIP 680 1/16W (1608)
R539	1-211-983-11	s	RESISTOR,CHIP 39 1/16W (1608)
R540	1-218-833-11	s	RESISTOR,CHIP 270 1/16W (1608)
R541	1-216-813-11	s	RESISTOR, CHIP 220 1/16W 1608
R542	1-216-813-11	s	RESISTOR, CHIP 220 1/16W 1608
R543	1-216-827-11	s	RESISTOR, CHIP 3.3K 1/16W 1608
R544	1-216-813-11	s	RESISTOR, CHIP 220 1/16W 1608
R545	1-216-813-11	s	RESISTOR, CHIP 220 1/16W 1608
R546	1-216-813-11	s	RESISTOR, CHIP 220 1/16W 1608
R547	1-216-813-11	s	RESISTOR, CHIP 220 1/16W 1608
R548	1-216-813-11	s	RESISTOR, CHIP 220 1/16W 1608
R549	1-216-813-11	s	RESISTOR, CHIP 220 1/16W 1608
R550	1-216-813-11	s	RESISTOR, CHIP 220 1/16W 1608
R552	1-216-813-11	s	RESISTOR, CHIP 220 1/16W 1608
R554	1-216-813-11	s	RESISTOR, CHIP 220 1/16W 1608
R555	1-216-809-11	s	RESISTOR,CHIP 100 1/16W 1608
R556	1-216-813-11	s	RESISTOR, CHIP 220 1/16W 1608
R557	1-216-813-11	s	RESISTOR, CHIP 220 1/16W 1608
R558	1-216-813-11	s	RESISTOR, CHIP 220 1/16W 1608
R559	1-216-813-11	s	RESISTOR, CHIP 220 1/16W 1608
R560	1-216-813-11	s	RESISTOR, CHIP 220 1/16W 1608
R561	1-216-809-11	s	RESISTOR,CHIP 100 1/16W 1608
R563	1-216-857-11	s	RESISTOR, CHIP 1.0M 1/16W 1608
R564	1-216-857-11	s	RESISTOR, CHIP 1.0M 1/16W 1608

(MA-99 BOARD)

Ref. No. or Q'ty	Part No.	SP	Description
R565	1-216-813-11	s	RESISTOR, CHIP 220 1/16W 1608
R566	1-216-813-11	s	RESISTOR, CHIP 220 1/16W 1608
R567	1-216-809-11	s	RESISTOR,CHIP 100 1/16W 1608
R568	1-216-809-11	s	RESISTOR,CHIP 100 1/16W 1608
R569	1-216-809-11	s	RESISTOR,CHIP 100 1/16W 1608
R570	1-216-809-11	s	RESISTOR,CHIP 100 1/16W 1608
R571	1-216-809-11	s	RESISTOR,CHIP 100 1/16W 1608
R572	1-216-809-11	s	RESISTOR,CHIP 100 1/16W 1608
R573	1-216-809-11	s	RESISTOR,CHIP 100 1/16W 1608
R574	1-216-809-11	s	RESISTOR,CHIP 100 1/16W 1608
R575	1-216-809-11	s	RESISTOR,CHIP 100 1/16W 1608
R576	1-216-809-11	s	RESISTOR,CHIP 100 1/16W 1608
R577	1-216-809-11	s	RESISTOR,CHIP 100 1/16W 1608
R578	1-216-809-11	s	RESISTOR,CHIP 100 1/16W 1608
R579	1-216-809-11	s	RESISTOR,CHIP 100 1/16W 1608
R580	1-216-809-11	s	RESISTOR,CHIP 100 1/16W 1608
R581	1-216-809-11	s	RESISTOR,CHIP 100 1/16W 1608
R582	1-216-809-11	s	RESISTOR,CHIP 100 1/16W 1608
R583	1-216-809-11	s	RESISTOR,CHIP 100 1/16W 1608
R584	1-216-809-11	s	RESISTOR,CHIP 100 1/16W 1608
R585	1-216-809-11	s	RESISTOR,CHIP 100 1/16W 1608
R586	1-216-809-11	s	RESISTOR,CHIP 100 1/16W 1608
R587	1-216-809-11	s	RESISTOR,CHIP 100 1/16W 1608
R588	1-216-809-11	s	RESISTOR,CHIP 100 1/16W 1608
R589	1-216-809-11	s	RESISTOR,CHIP 100 1/16W 1608
R590	1-216-809-11	s	RESISTOR,CHIP 100 1/16W 1608
R591	1-216-809-11	s	RESISTOR,CHIP 100 1/16W 1608
R592	1-216-809-11	s	RESISTOR,CHIP 100 1/16W 1608
R593	1-216-809-11	s	RESISTOR,CHIP 100 1/16W 1608
R594	1-216-809-11	s	RESISTOR,CHIP 100 1/16W 1608
R595	1-216-809-11	s	RESISTOR,CHIP 100 1/16W 1608
R596	1-216-864-11	s	RESISTOR,CHIP 0 1/16W (1608)
R597	1-216-864-11	s	RESISTOR,CHIP 0 1/16W (1608)
RV2	1-241-178-21	s	RESISTOR ADJ 4.7K (CERMET)
RV3	1-238-087-11	s	RESISTOR ADJ 1K (CERMET)
RV4	1-238-090-11	s	RESISTOR,ADJ 10K (CERMET)
RV5	1-238-090-11	s	RESISTOR,ADJ 10K (CERMET)
RV6	1-241-092-11	s	RESISTOR,ADJ 1K (CERMET)(3MM)
RY1	1-515-614-11	s	RELAY (12V)
S300	1-762-299-11	s	SWITCH, DIP (PIANO TYPE)
X300	1-767-464-11	s	VIBRATOR, CRYSTAL
X500	1-767-425-21	s	VIBRATOR, CRYSTAL

 SE-531 BOARD

Ref. No. or Q'ty	Part No.	SP Description
1pc	A-8323-916-A	o MOUNTED CIRCUIT BOARD, SE-531
CN31	1-573-806-21	s PIN,CONNECTOR (6P)(SMD)(1.5MM)
PH21	8-719-052-69	s PHOTO INTERRUPTER RPI-352
PH22	8-719-052-69	s PHOTO INTERRUPTER RPI-352
PH31	8-719-988-59	s PHOTO TRANSISTOR PT501A
PH32	8-749-010-50	s PHOTO INTERUPTER RPI-5100
R21	1-216-073-00	s RESISTOR,CHIP 10K 1/10W(2012)
R22	1-216-029-00	s RESISTOR,CHIP 150 1/10W(2012)
R23	1-216-073-00	s RESISTOR,CHIP 10K 1/10W(2012)
R24	1-216-029-00	s RESISTOR,CHIP 150 1/10W(2012)
R31	1-216-029-00	s RESISTOR,CHIP 150 1/10W(2012)
R32	1-216-073-00	s RESISTOR,CHIP 10K 1/10W(2012)

 SE-532 BOARD

Ref. No. or Q'ty	Part No.	SP Description
1pc	A-8323-917-A	o MOUNTED CIRCUIT BOARD, SE-532
1pc	3-689-205-02	s HOLDER (A), LED
1pc	3-187-312-02	s HOLDER (P), LED
C11	1-164-004-11	s CAPACITOR,CERAMIC 0.1MF/25V
C12	1-164-004-11	s CAPACITOR,CERAMIC 0.1MF/25V
CN11	1-580-056-21	o PIN,CONNECTOR 3P
D11	8-719-945-20	s LED GL-520
PH12	8-729-019-26	s TRANSISTOR PT493F
R11	1-216-023-00	s RESISTOR,CHIP 82 1/10W(2012)
R12	1-216-047-91	s RESISTOR, CHIP 820 1/10W(2125)

 SU-52 BOARD

Ref. No. or Q'ty	Part No.	SP Description
1pc	1-676-696-11	o PRINTED WIRING BOARD, SU-52
CN41	1-770-160-21	s PIN, CONNECTOR (SMT) 2P

 FRAME

Ref. No. or Q'ty	Part No.	SP Description
1pc	1-251-855-11	s HEAD, THERMAL (LVE6413SS)
1pc	1-418-820-11	s PANEL UNIT, FRONT
1pc	△ 1-468-456-12	s REGULATOR, SWITCHING
1pc	1-541-309-11	s MOTOR, (RF-370C)(DC)(2.59W)
1pc	1-698-928-22	s MOTOR, STEPPING
1pc	1-763-007-21	o FAN, DC (OPTION)
1pc	1-792-200-11	o WIRE, FLAT TYPE (8 CORE)
1pc	1-792-201-11	o WIRE, FLAT TYPE (26 CORE)
1pc	1-792-202-11	o WIRE, FLAT TYPE (30 CORE)
HN001	1-960-220-11	o HARNESS, SUB (6P) (TO CN2/MA-99 BOARD)
	1-569-200-11	o HOUSING, CONNECTOR 7P
6pcs	1-569-193-21	o TERMINAL, SOLDERLESS (TO CN31/SE-531 BOARD)
	1-565-978-11	o HOUSING, CONNECTOR 6P
6pcs	1-565-977-11	s TERMINAL, SOLDERLESS
HN002	1-960-221-11	o HARNESS, SUB (3P) (TO CN2/KY-454 BOARD)
	1-569-618-11	o HOUSING, CONNECTOR 3P
3pcs	1-565-977-11	s TERMINAL, SOLDERLESS (TO CN11/SE-532 BOARD)
	1-569-618-11	o HOUSING, CONNECTOR 3P
3pcs	1-565-977-11	s TERMINAL, SOLDERLESS
HN003	1-960-222-11	o HARNESS, SUB (2P) (TO CN7/MA-99 BOARD)
	1-569-196-11	o HOUSING, CONNECTOR 3P
2pcs	1-569-193-21	o TERMINAL, SOLDERLESS (TO CN41/SU-52 BOARD)
	1-562-644-11	s SOCKET, CONNECTOR 2P
2pcs	1-562-643-11	o TERMINAL, SOLDERLESS

 PACKING MATERIALS & SUPPLIED ACCESSORIES

Ref. No. or Q'ty	Part No.	SP Description
1pc	△ 1-534-827-14	s CORD, POWER (3P)(UL/CSA) [UP-895(UC)]
1pc	1-551-475-31	s 3C2V 1.5M CABLE [UP-895(J,UC)] [UP-895CE(CE)] [UP-895MD(J,UC)]
1pc	△ 1-551-631-22	s POWER-SUPPLY CORD (IEC) [UP-895CE(CE)]
1pc	△ 1-575-703-12	s CORD, POWER [UP-895MD(J)]
1pc	△ 1-783-954-11	s CORD, POWER [UP-895MD(UC)]
1pc	△ 1-791-041-11	s CORD SET, POWER (3P) [UP-895(J)]
1pc	△ 1-793-461-11	o PLUG, CONVERSION (3P-2P) [UP-895(J),UP-895MD(J)]
1pc	3-623-865-01	s SHEET, HEAD CLEANING (ACLYLIC)
1pc	3-624-867-01	o LABEL, MEDIA
1pc	3-868-286-01	s MANUAL, INSTRUCTION

Section 9 Block Diagram

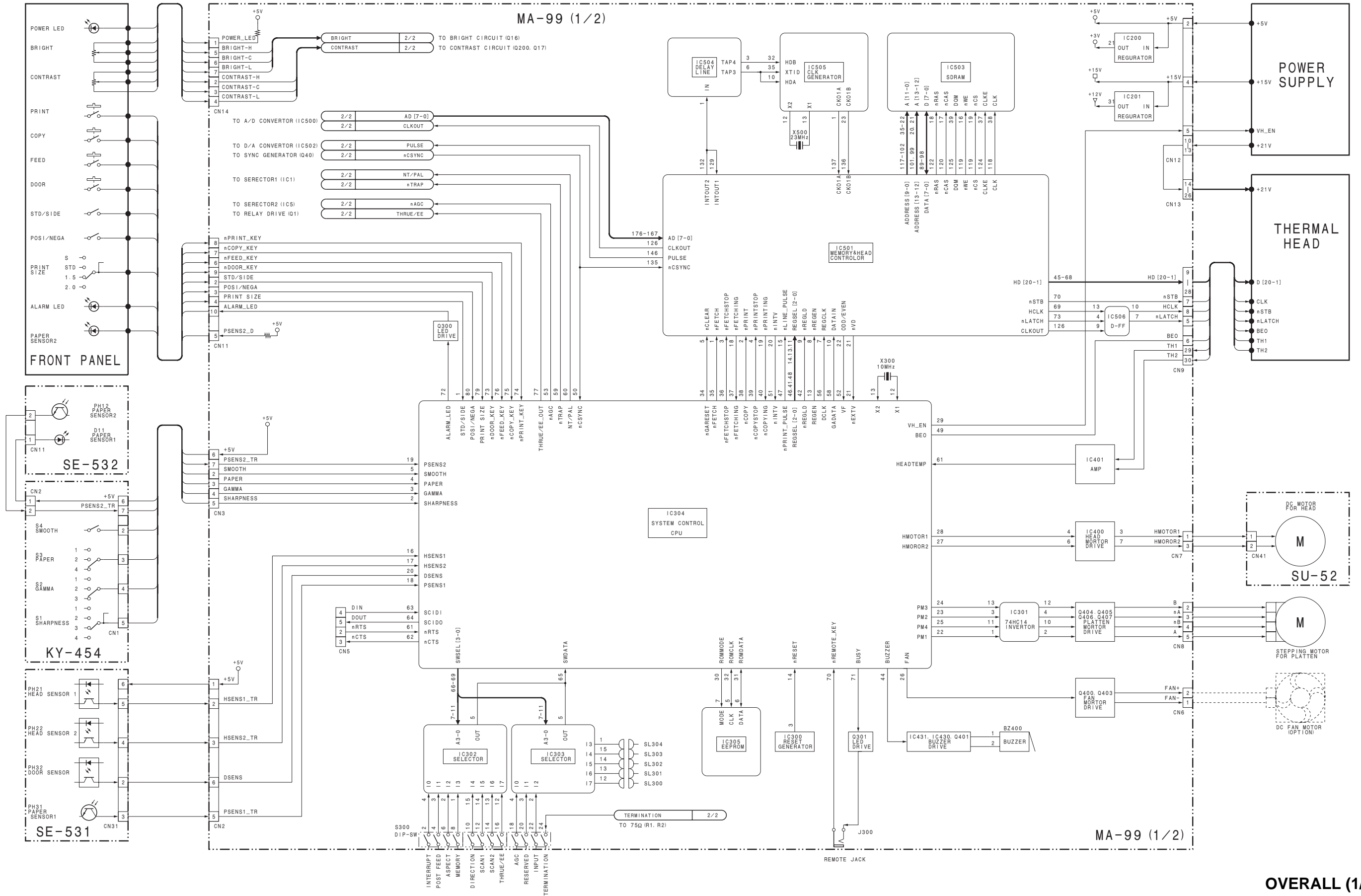

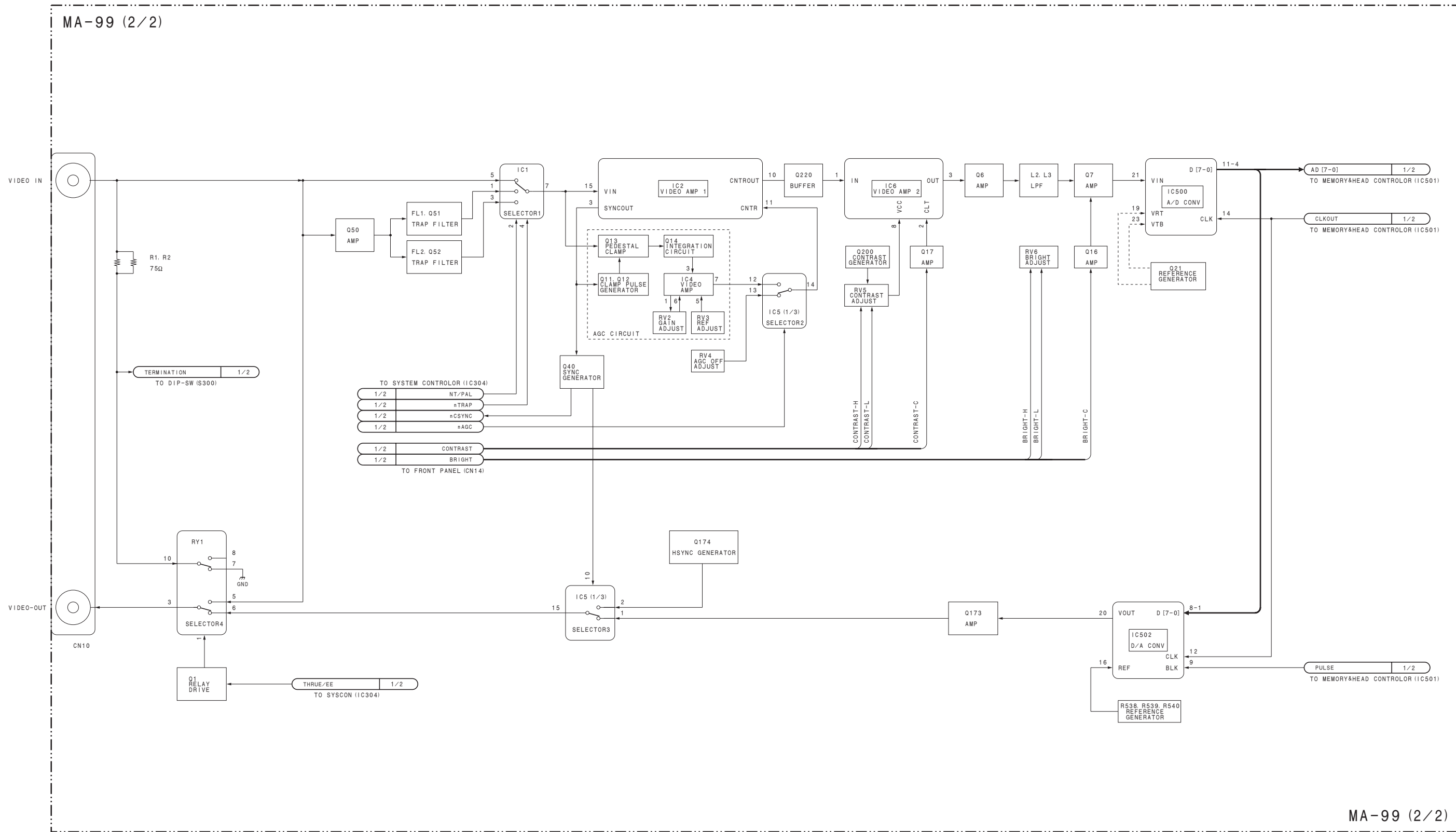

MA-99 (2/2)

Section 10
Schematic Diagrams and Board Layouts

1

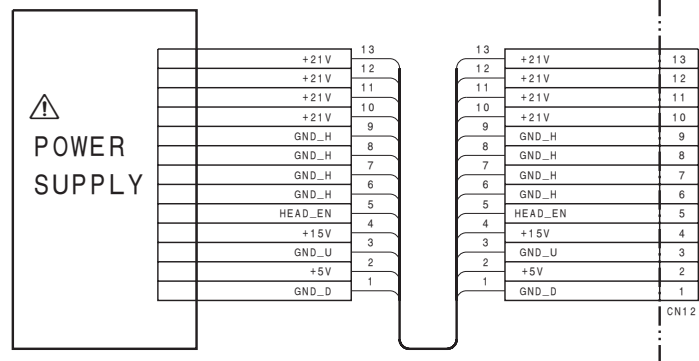
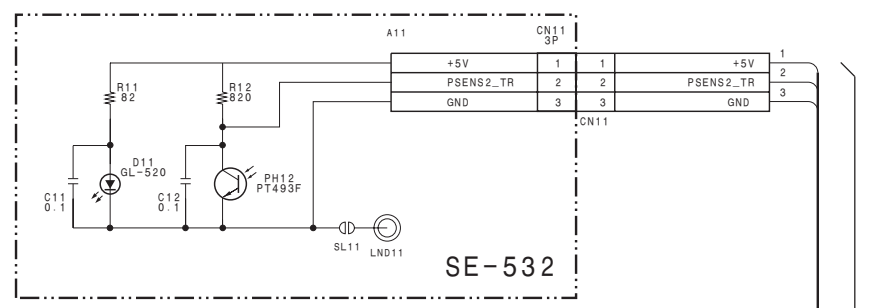

2

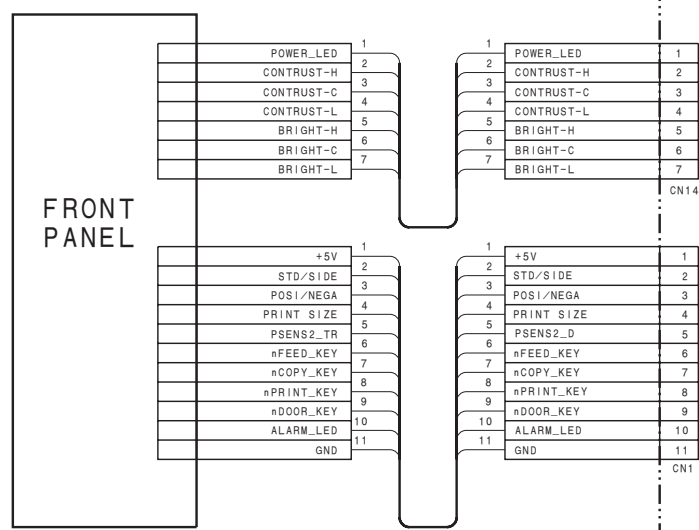
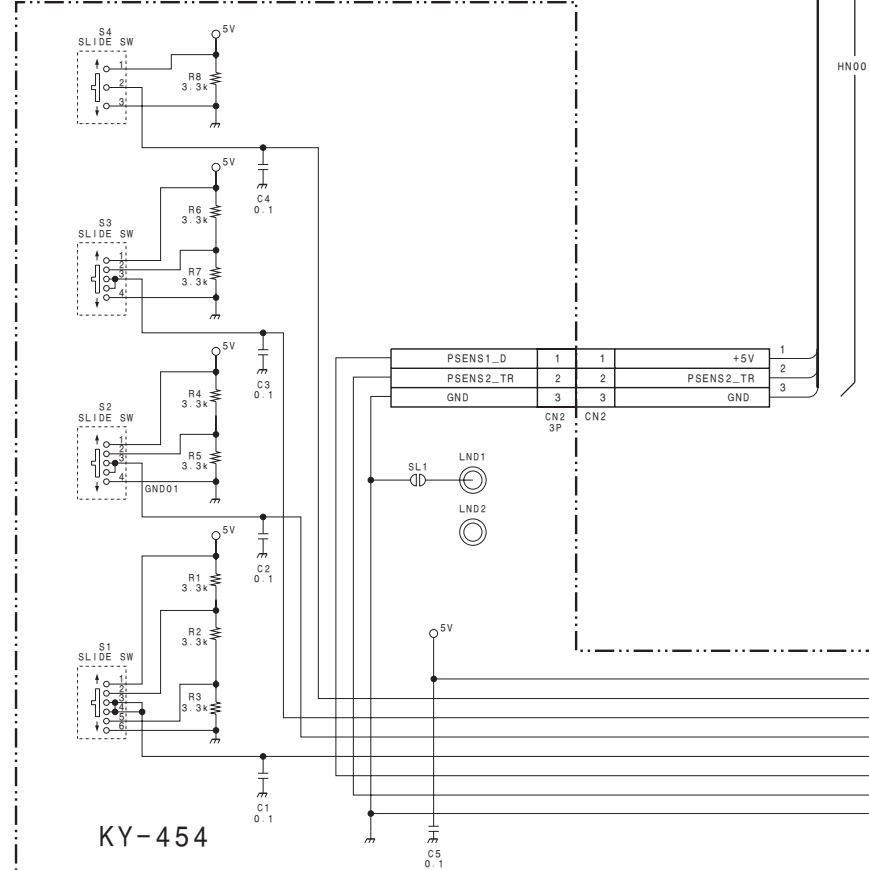

3

MA-99

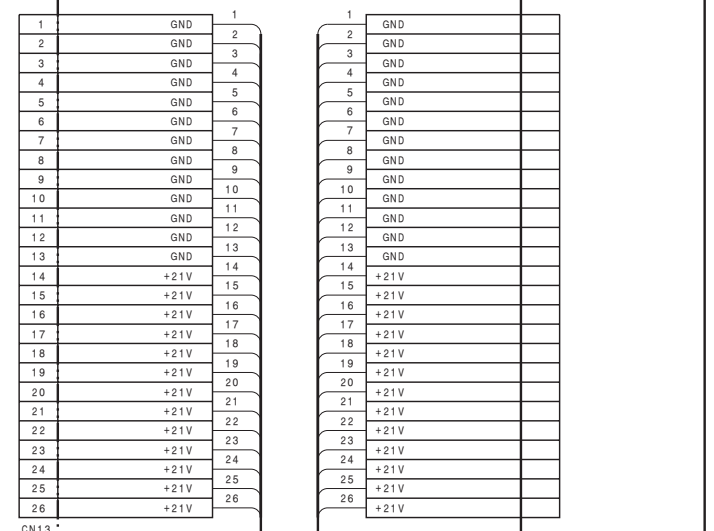

THERMAL HEAD

4

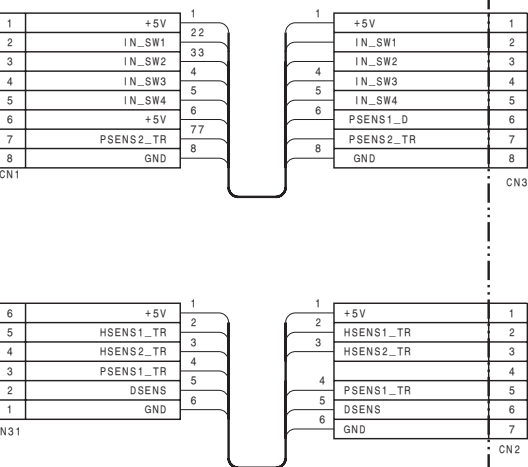
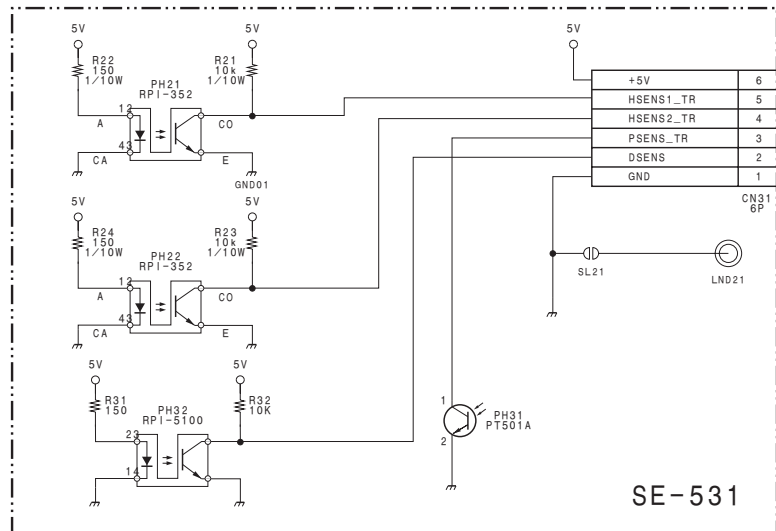

5

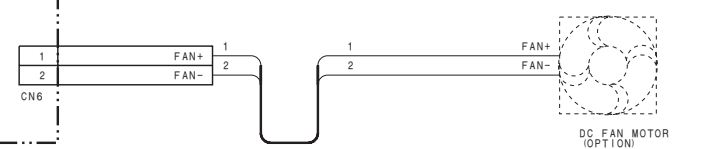
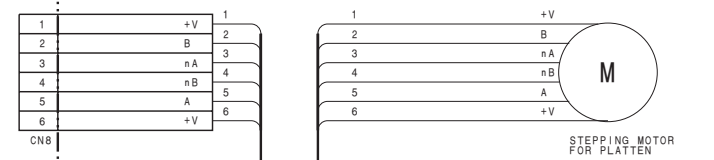
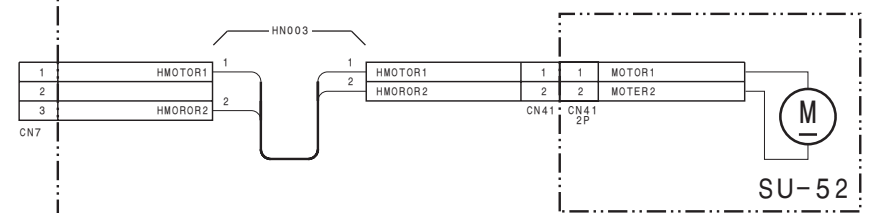
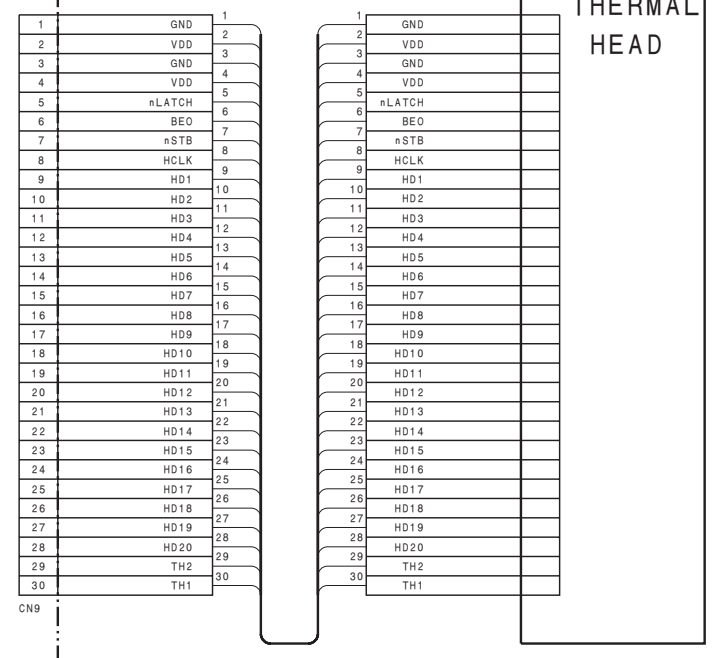

FRAME

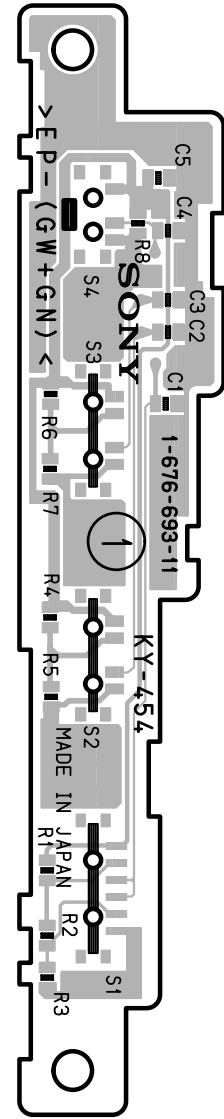

KY-454 -A SIDE-
SUFFIX: -11

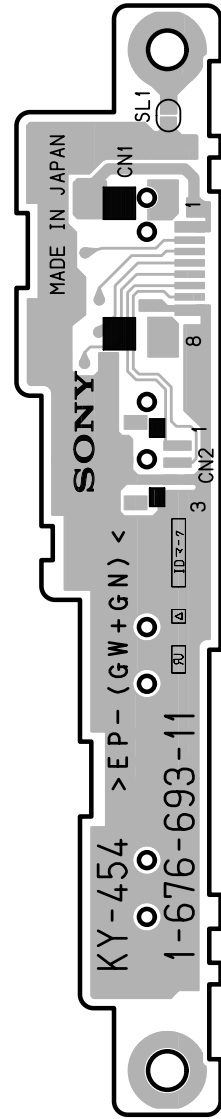

KY-454 -B SIDE-
SUFFIX: -11

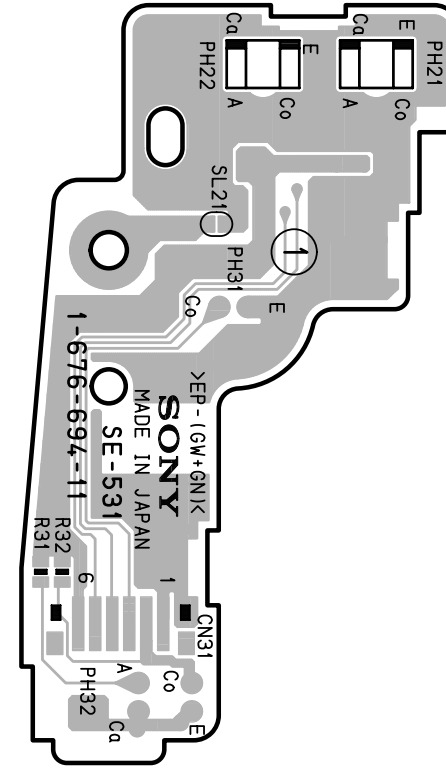

SE-531 -A SIDE-
SUFFIX: -11

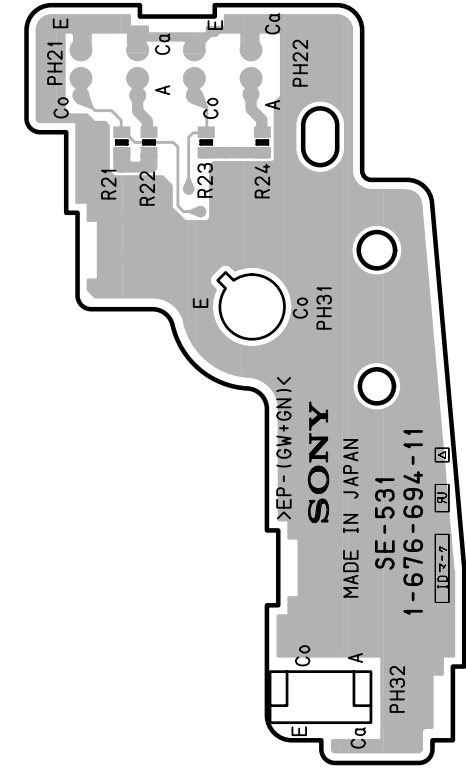

SE-531 -B SIDE-
SUFFIX: -11

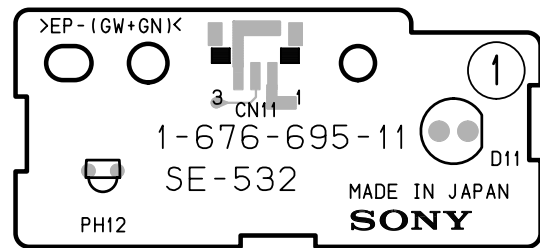

SE-532 -A SIDE-
SUFFIX: -11

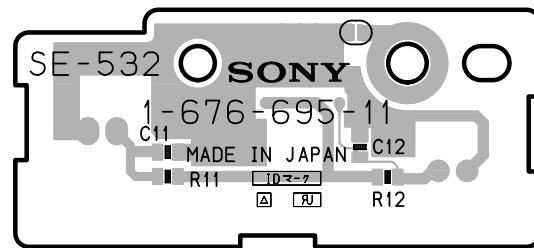

SE-532 -B SIDE-
SUFFIX: -11

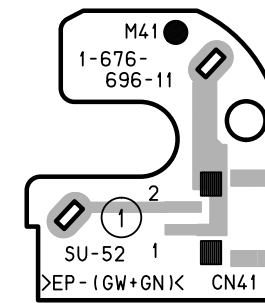

SU-52 -A SIDE-
SUFFIX: -11

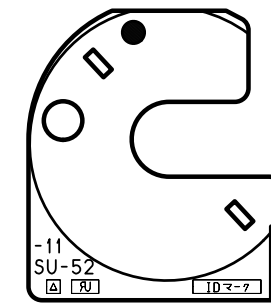

SU-52 -B SIDE-
SUFFIX: -11

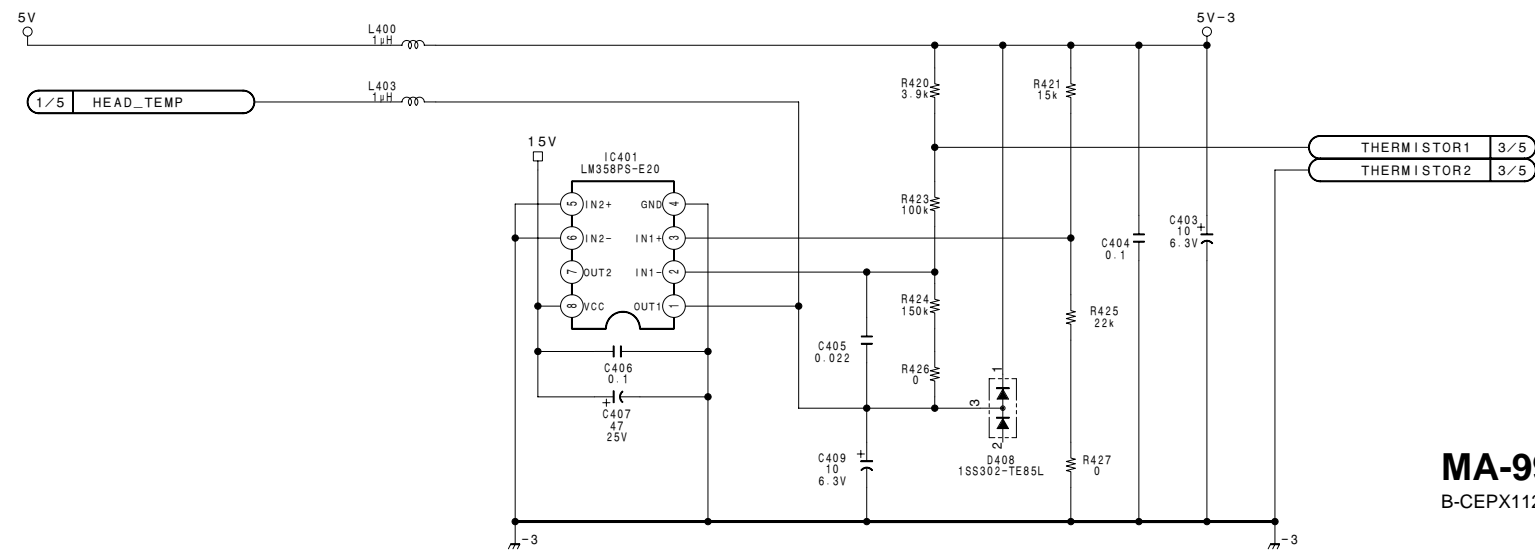
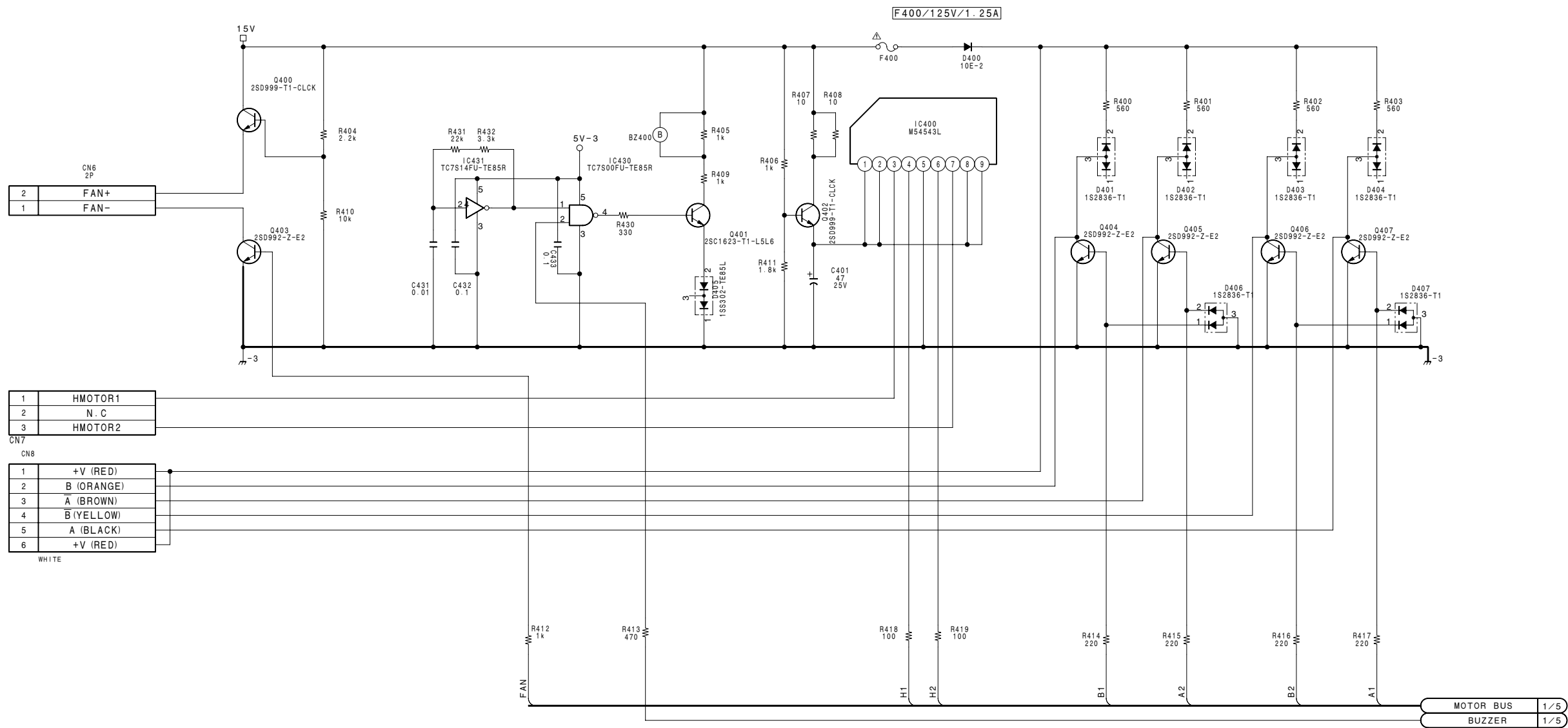

MA-99 (2/5)
B-CEPX112-MA99-S

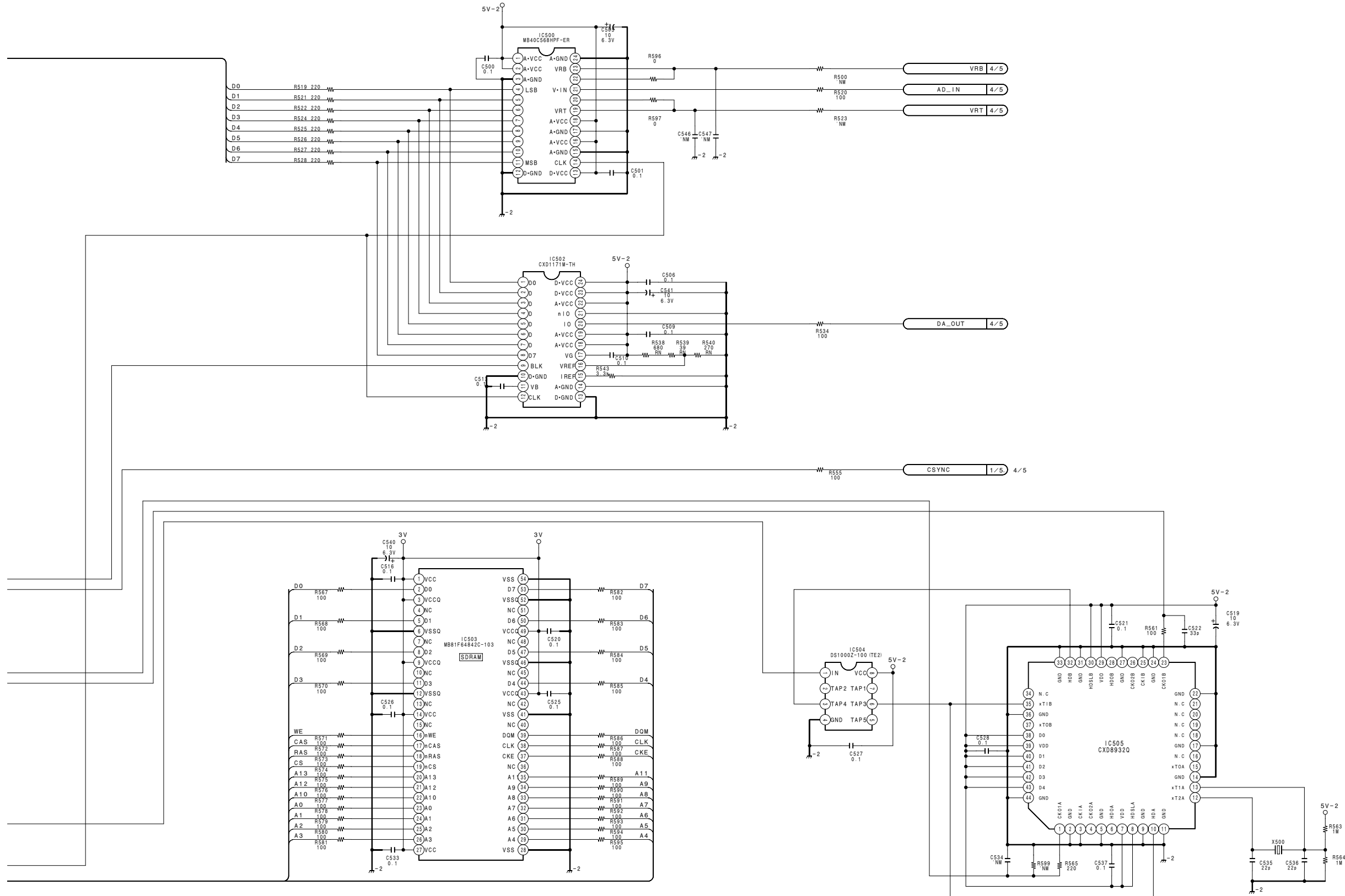

MA-99 (3/5)
B-CEPX112-MA99-S

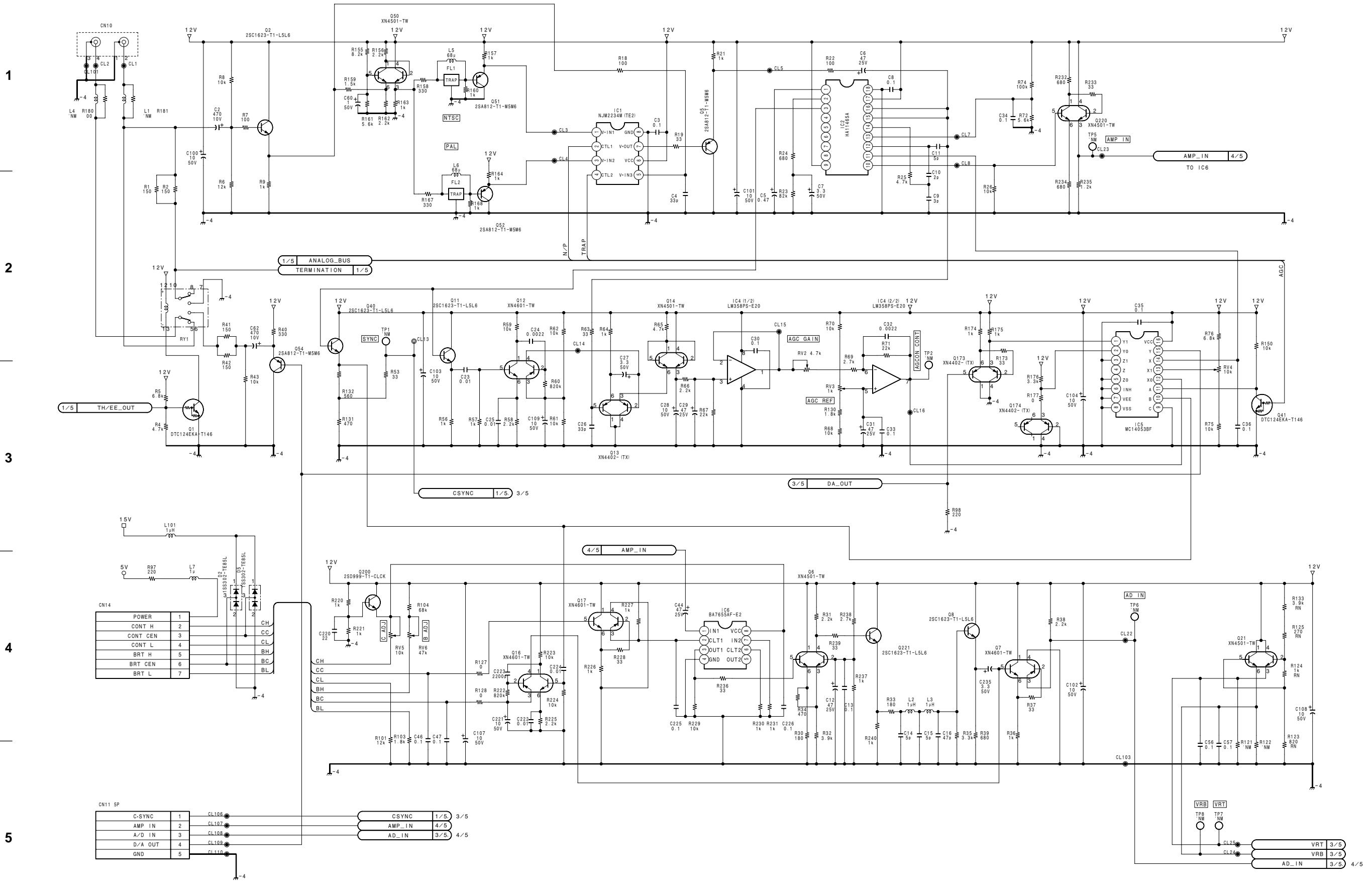

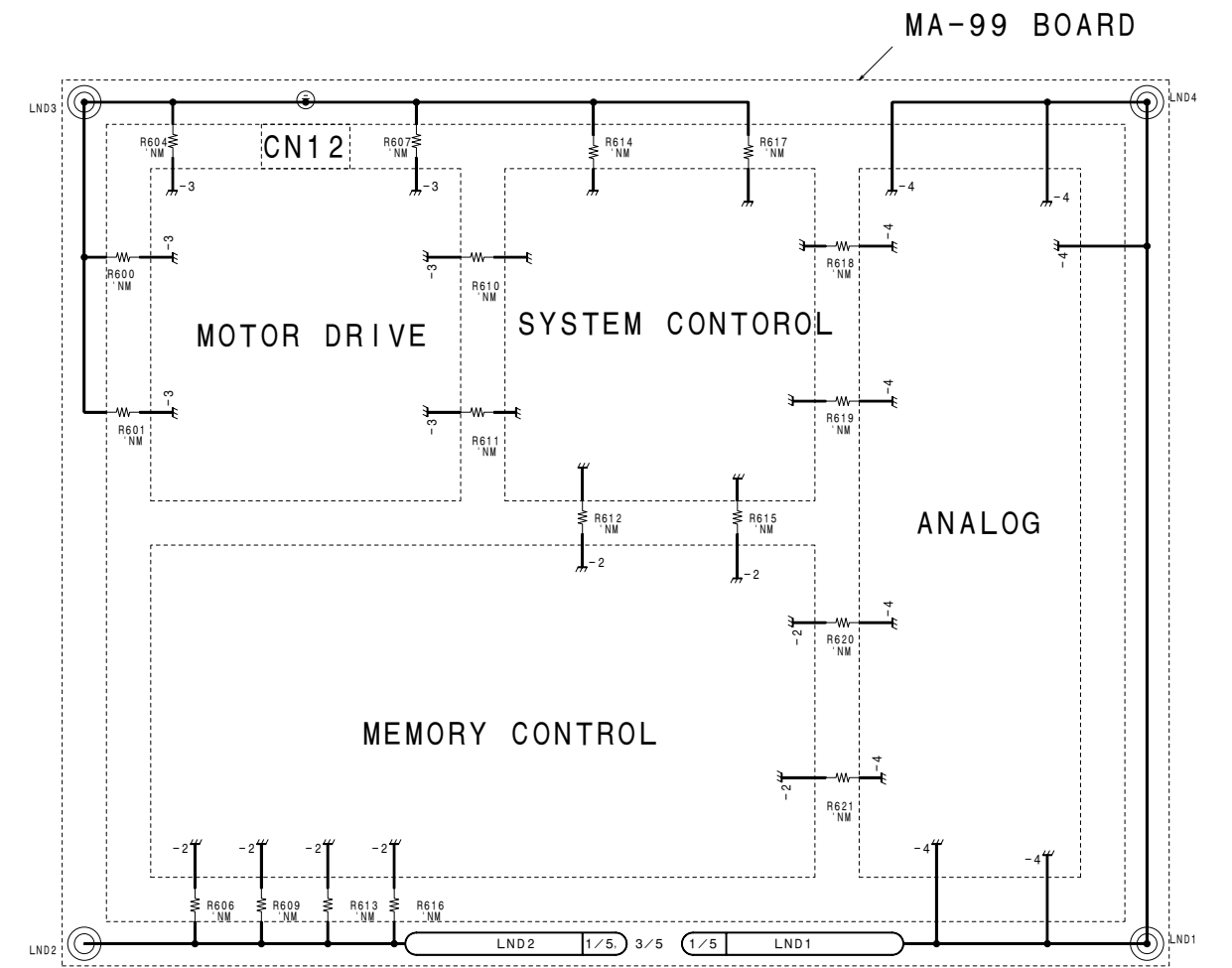
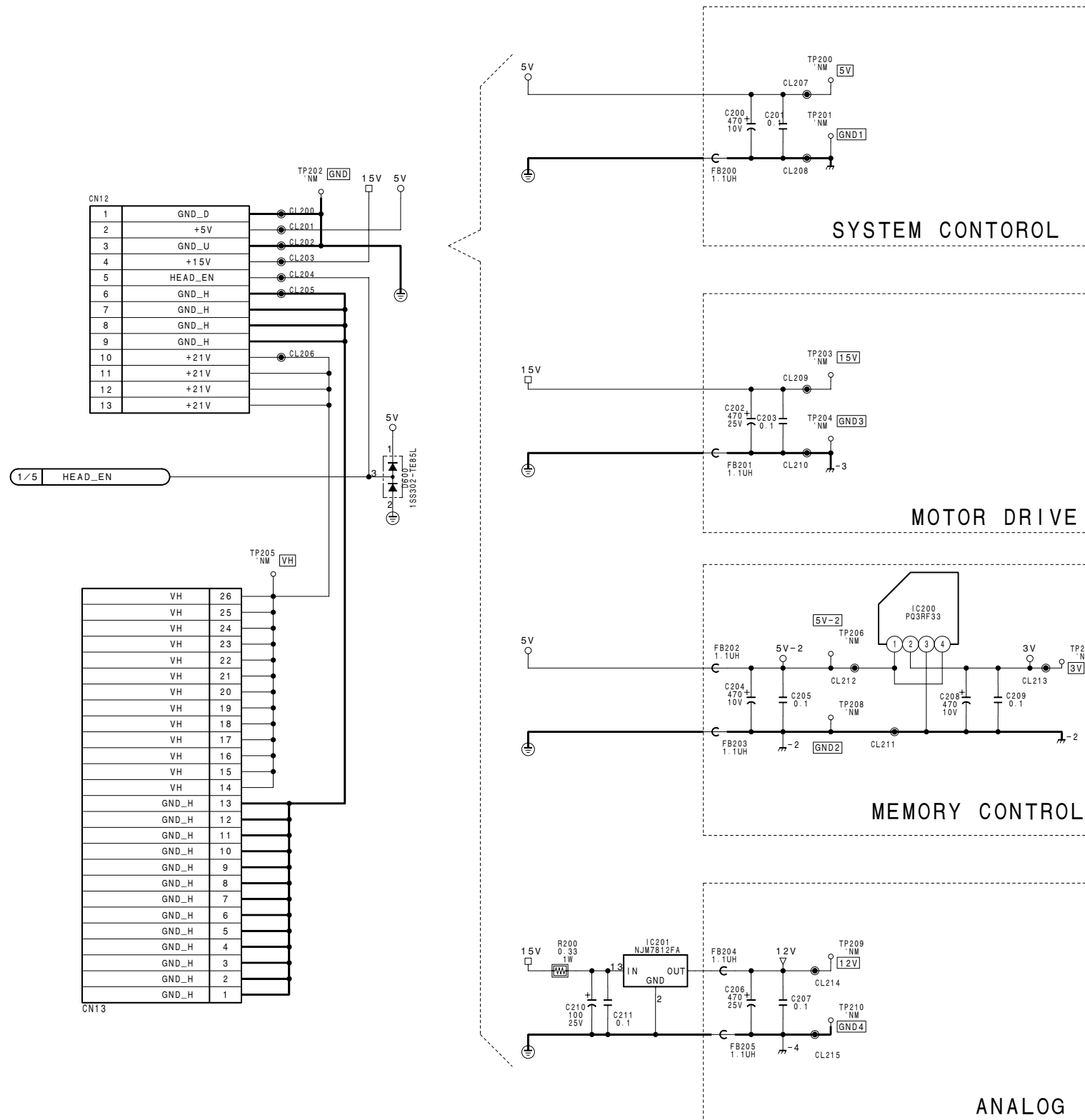

MA-99 (5/5)
B-CEPX112-MA99-S

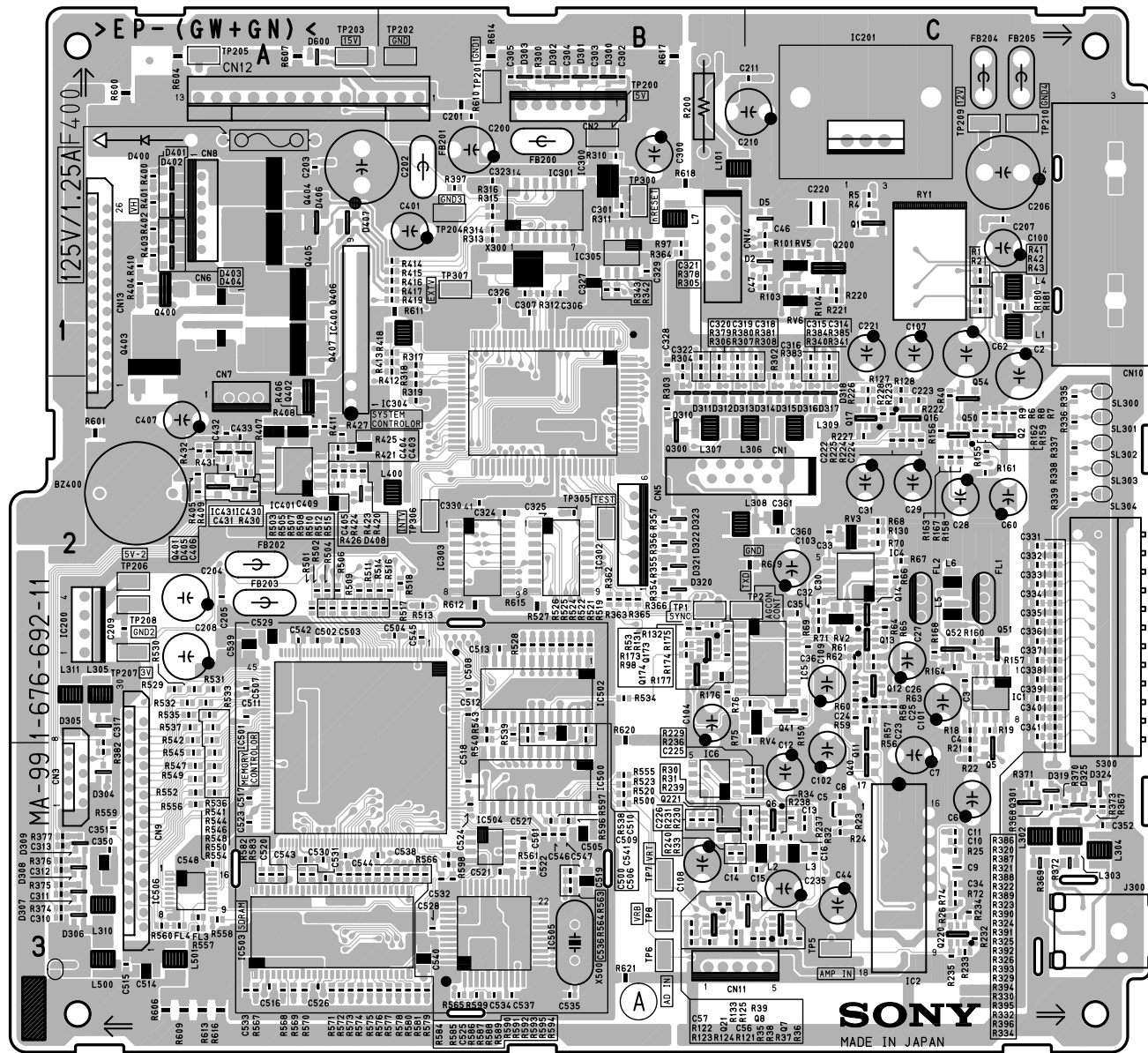

MA-99 -A SIDE-
SUFFIX: -11

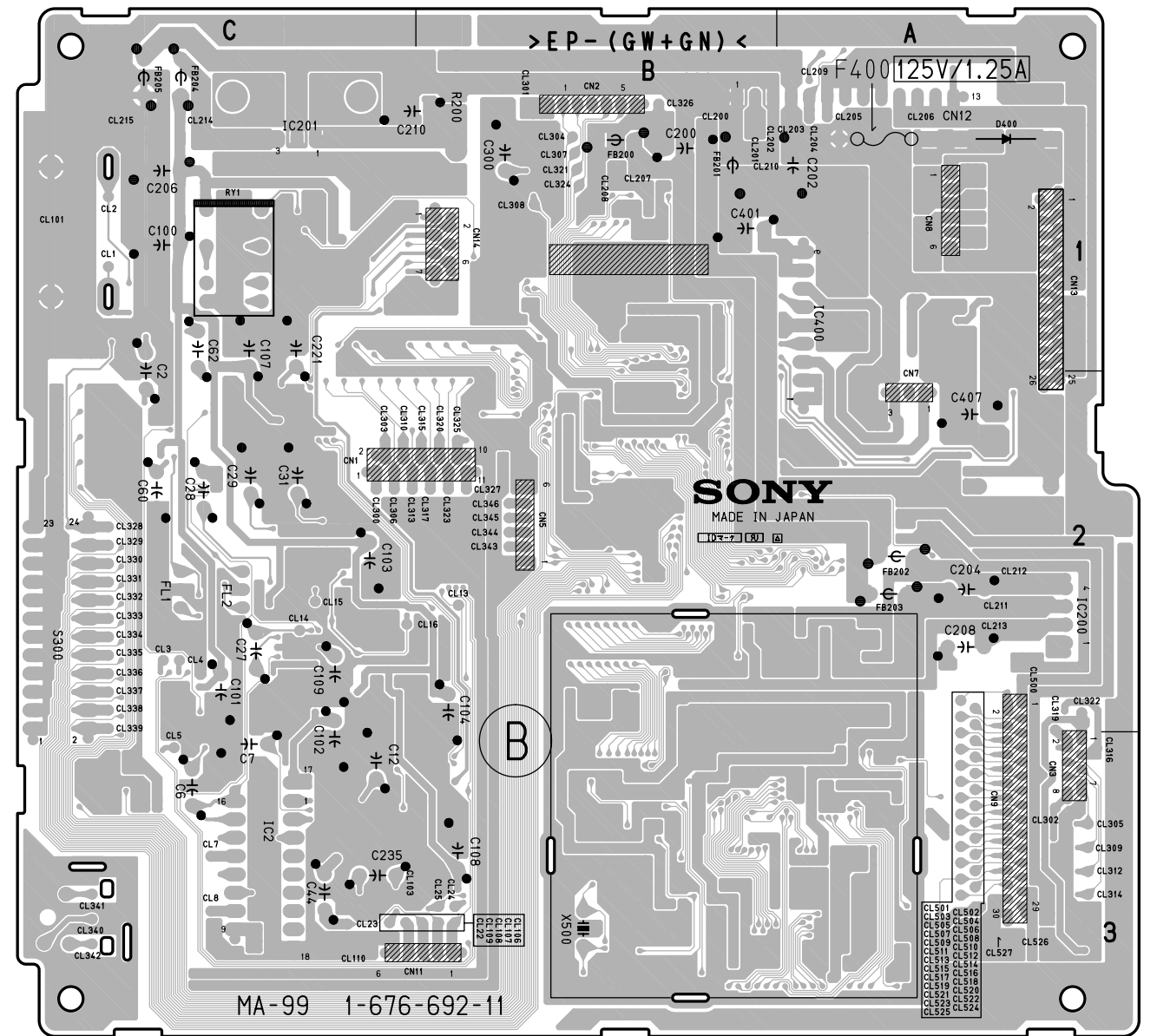

MA-99 -B SIDE-
SUFFIX: -11

MA-99 (1-676-692-11)

*:B SIDE

BZ400	A2	C332	C2	CL109	*C3	CN6	A1	L5	C2	R56	C2	R320	C2	R505	A2	R607	A1
		C333	C2	CL110	*C3	CN7	A2	L6	C2	R57	C2	R321	C2	R506	A2	R609	A3
C2	C2	C334	C2	CL200	*B1	CN8	A1	L7	B1	R58	C2	R322	C2	R507	A2	R610	B1
C3	C2	C335	C2	CL201	*B1	CN9	A3	L101	B1	R59	C2	R323	C2	R508	A2	R611	B1
C4	C2	C336	C2	CL202	*B1	CN10	C1	L302	C3	R60	C2	R324	C2	R509	A2	R612	B2
C5	C3	C337	C2	CL203	*A1	CN11	B3	L303	C3	R61	C2	R325	C2	R510	A2	R613	A3
C6	C3	C338	C2	CL204	*A1	CN12	B1	L304	C3	R62	C2	R326	C2	R511	A2	R614	B1
C7	C3	C339	C2	CL205	*A1	CN13	A2	L305	A2	R63	C2	R329	C2	R512	A2	R615	B2
C8	C3	C340	C2	CL206	*A1	CN14	B1	L306	C2	R64	C2	R330	C2	R513	B2	R616	A3
C9	C3	C341	C2	CL207	*B1			L307	B2	R65	C2	R332	C2	R514	B2	R617	B1
C10	C3	C350	A3	CL208	*B1	D2	C1	L308	B2	R66	C2	R334	C3	R515	B2	R618	B1
C11	C3	C351	A3	CL209	*A1	D5	C1	L309	C2	R67	C2	R335	C2	R516	B2	R619	C2
C12	C3	C352	C3	CL210	*B1	D300	B1	L310	A3	R68	C2	R336	C2	R517	B2	R620	B2
C13	C3	C360	C2	CL211	*A2	D301	B1	L311	A2	R69	C2	R337	C2	R518	B2	R621	B3
C14	B3	C361	C2	CL212	*A2	D302	B1	L400	B2	R70	C2	R338	C2	R519	B2		
C15	C3	C362	B1	CL213	*A2	D303	B1	L403	B1	R71	C2	R339	C2	R520	B3	RV2	C2
C16	C3	C401	B1	CL214	*C1	D304	A3	L500	A3	R72	C3	R340	C2	R521	B2	RV3	C2
C23	C2	C403	A2	CL215	*C1	D305	A2	L501	A3	R74	C3	R341	C2	R522	B2	RV4	C2
C24	C2	C404	A2	CL300	*C2	D306	A3			R75	C2	R342	B1	R523	B3	RV5	C1
C25	C2	C405	A2	CL301	*B1	D307	A3	LND1	C3	R76	C2	R343	B1	R524	B2	RV6	C1
C26	C2	C406	A2	CL302	*A3	D308	A3	LND2	A3	R97	B1	R354	B2	R525	B2		
C27	C2	C407	A2	CL303	*C2	D309	A3	LND3	A1	R98	B2	R355	B2	R526	B2	RY1	C1
C28	C2	C409	A2	CL304	*B1	D310	B2	LND4	C1	R101	C1	R356	B2	R527	B2		
C29	C2	C431	A2	CL305	*A3	D311	B2	LND301	*C3	R103	C1	R357	B2	R528	B2	S300	C2
C30	C2	C432	A2	CL306	*C2	D312	B2	LND302	*C3	R104	C1	R362	B2	R529	A2		
C31	C2	C433	A2	CL307	*B1	D313	B2	LND501	*B2	R121	B3	R363	B2	R530	A2	SL300	C2
C32	C2	C500	B2	CL308	*B1	D314	C2	LND502	*B3	R122	B3	R364	B1	R531	A2	SL301	C2
C33	C2	C501	B3	CL309	*A3	D315	C2	LND503	*A3	R123	B3	R365	B2	R532	A2	SL302	C2
C34	C3	C502	A2	CL310	*C2	D316	C2	LND504	*B3	R124	B3	R366	B2	R533	A2	SL303	C2
C35	C2	C503	A2	CL312	*A3	D317	C2			R125	B3	R367	C3	R534	B2	SL304	C2
C36	C2	C504	B2	CL313	*C2	D318	C2	Q1	C1	R127	C2	R368	C3	R535	A2	SL305	A3
C44	C3	C505	B3	CL314	*A3	D319	C3	Q2	C2	R128	C2	R369	C3	R536	A2		
C46	C1	C506	B2	CL315	*B2	D320	B2	Q5	C3	R130	C2	R370	C3	R537	A2	TP1	B2
C47	C1	C507	A2	CL316	*A3	D321	B2	Q6	C3	R131	B2	R371	C3	R538	B2	TP2	C2
C56	B3	C508	B2	CL317	*B2	D322	B2	Q7	C3	R132	B2	R372	C3	R539	B2	TP5	C3
C57	B3	C509	B2	CL319	*A2	D323	B2	Q8	C3	R133	B3	R373	C3	R540	B2	TP6	B3
C60	C2	C510	B2	CL320	*B2	D324	C3	Q11	C2	R150	C2	R374	A3	R541	A2	TP7	B3
C62	C1	C511	A2	CL321	*B1	D325	C3	Q12	C2	R155	C2	R375	A3	R542	A2	TP8	B3
C100	C1	C512	B2	CL322	*A2	D400	A1	Q13	C2	R156	C2	R376	A3	R543	B2	TP200	B1
C101	C2	C513	B2	CL323	*B2	D401	A1	Q14	C2	R157	C2	R377	A3	R544	A2	TP201	B1
C102	C2	C514	A3	CL324	*B1	D402	A1	Q16	C2	R158	C2	R378	B1	R545	A3	TP202	B1
C103	C2	C515	A3	CL325	*B2	D403	A1	Q17	C2	R159	C2	R379	B1	R546	A3	TP203	A1
C104	B2	C516	A3	CL326	*B1	D404	A1	Q21	B3	R160	C2	R380	B1	R547	A3	TP204	B1
C107	C1	C517	A3	CL327	*B2	D405	A2	Q40	C3	R161	C2	R381	C1	R548	A3	TP205	A1
C108	B3	C518	B3	CL328	*C2	D406	A1	Q41	C2	R162	C2	R382	A3	R549	A3	TP206	A2
C109	C2	C519	B3	CL329	*C2	D407	A1	Q50	C2	R163	C2	R383	C2	R550	A3	TP207	A2
C200	B1	C520	A3	CL330	*C2	D408	A2	Q51	C2	R164	C2	R384	C1	R552	A3	TP208	A2
C201	B1	C521	B3	CL331	*C2	D600	A1	Q52	C2	R167	C2	R385	C1	R554	A3	TP209	C1
C202	A1	C522	B3	CL332	*C2			Q54	C2	R168	C2	R386	C2	R555	B3	TP210	C1
C203	A1	C523	A3	CL333	*C2	F400	A1	Q173	B2	R173	B2	R387	C2	R556	A3	TP300	B1
C204	A2	C524	B3	CL334	*C2			Q174	B2	R174	B2	R388	C2	R557	A3	TP305	B2
C205	A2	C525	A3	CL335	*C2	FB200	B1	Q200	C1	R175	B2	R389	C2	R558	A3	TP306	B2
C206	C1	C526	A3	CL336	*C2	FB201	B1	Q220	C3	R176	B2	R390	C2	R559	A3	TP307	B1
C207	C1	C527	B3	CL337	*C2	FB202	A2	Q221	B3	R177	B2	R391	C2	R560	A3		
C208	A2	C528	B3	CL338	*C2	FB203	A2	Q300	B2	R180	C1	R392	C2	R561	B3	X300	B1
C209	A2	C529	A2	CL339	*C2	FB204	C1	Q301	C3	R181	C1	R393	C2	R563	B3	X500	B3
C210	B1	C530	A3	CL340	*C3	FB205	C1	Q400	A1	R200	B1	R394	C2	R564	B3		
C211	C1	C531	A3	CL341	*C3			Q401	A2	R220	C1	R395	C2	R565	B3		
C220	C1	C532	B3	CL342	*C3	FL1	C2	Q402	A2	R221	C1	R396	C2	R566	B3		
C221	C1	C533	A3	CL343	*B2	FL2	C2	Q403	A1	R222	C2	R397	B1	R567	A3		
C222	C2	C534	B3	CL344	*B2	FL3	A3	Q404	A1	R223	C2	R398	B2	R568	A3		
C223	C2	C535	B3	CL345	*B2	FL4	A3	Q405	A1	R224	C2	R400	A1	R569	A3		
C224	C2	C536	B3	CL346	*B2			Q406	A1	R225	C2	R401	A1	R570	A3		
C225	C3	C537	B3	CL500	*A2	IC1	C2	Q407	A1	R226	C2	R402	A1	R571	A3		
C226	B3	C538	B3	CL501	*A2	IC2	C3			R227	C2	R403	A1	R572	A3		
C235	C3	C539	A2	CL502	*A2	IC4	C2	R1	C1	R228	C2	R404	A1	R573	A3		
C300	B1	C540	B3	CL503	*A2	IC5	C2	R2	C1	R229	C3	R405	A2	R574	A3		
C301	B1	C541	B2	CL504	*A2	IC6	B3	R4	C1	R230	B3	R406	A2	R575	A3		
C302	B1	C542	A2	CL505	*A3	IC200	A2	R5	C1	R231	B3	R407	A2	R576	B3		
C303	B1	C543	A3	CL506	*A3	IC201	C1	R6	C2	R232	C3	R408	A2	R577	B3		
C304	B1	C544	A3	CL507	*A3	IC300	B1	R7	C2	R233	C3	R409	A2	R578	B3		
C305	B1	C545	B2	CL508	*A3	IC301	B1	R8	C2	R234	C3	R410	A1	R579	B3		
C306	B1	C546	B3	CL509	*A3	IC302	B2	R9	C2	R235	C3	R411	A2	R580	B3		
C307	B1	C547	B3	CL510	*A3	IC303	B2	R18	C2	R236	C3	R412	B1	R581	B3		
C310	A3	C548	A3	CL511	*A3	IC304	B2	R19	C2	R237	C3	R413	B1	R582	A3		
C311	A3			CL512	*A3	IC305	B1	R21	C3	R238	C3	R414	B1	R583	A3		
C312	A3	CL1	*C1	CL513	*A3	IC400	A2	R22	C3	R239	C3	R415	B1	R584	A3		
C313	A3	CL2	*C1	CL514	*A3	IC401	A2	R23	C3	R240	B3	R416	B1	R585	A3		
C314	C1	CL3	*C2	CL515	*A3	IC430	A2	R24	C3	R300	B1	R417	B1	R586	A3		
C315	C1	CL4	*C2	CL516	*A3	IC431	A2	R25	C3	R302	C2	R418	B1	R587	A3		
C316	C1	CL5	*C3	CL517	*A3	IC500	B3	R26	C3	R303	B2	R419	B1	R588	A3		
C317	A2	CL7	*C3	CL518	*A3	IC501	A3	R30	C3	R304	B2	R420	A2	R589	A3		
C318	C1	CL8	*C3	CL519	*A3	IC502	B2	R31	C3	R305	B2	R421	A2	R590	A3		
C319	B1	CL13	*B2	CL520	*A3	IC503	A3	R32	C3	R306	B2	R423	A2	R591	B3		
C320	B1	CL14	*C2	CL521	*A3	IC504	B3	R33	B3	R307	B2	R424	A2	R592	B3		
C321	B1	CL15	*C2	CL522	*A3	IC505	B3	R34	C3	R308	C2	R425	A2	R593	B3		
C322	B1	CL16	*C2	CL523	*A3	IC506	A3	R35	C3	R310	B1	R426	A2	R594	B3		
C323	B1	CL22	*C3	CL524	*A3			R36	C3	R311	B1	R427	A2	R595	B3		
C324	B2	CL23	*C3	CL525	*A3	J300	C3	R37	C3	R312	B1	R430	A2	R596	B3		
C325	B2	CL24	*B3	CL526	*A3			R38	C3	R313	B1	R431	A2	R597	B3		
C326	B1	CL25	*B3	CL527	*A3	KA1	A1	R39	C3	R314	B1	R432	A2	R598	B3		
C327	B1	CL101	*C1					R40	C2	R315	B1	R500	B3	R599	B3		
C328	B1	CL103	*C3	CN1	C2	L1	C1	R41	C1	R316	B1	R501	A2	R600	A1		
C329	B1	CL106	*B3	CN2	B1	L2	C3	R42	C1	R317	B1	R502	A2	R601	A2		
C330	B2	CL107	*B3	CN3	A3	L3	C3	R43	C1	R318	B1	R503	A2	R604	A1		
C331	C2																

SAFETY CHECK-OUT

After correcting the original service problem, perform the following safety checks before releasing the set to the customer :

Check the metal trim, "metallized" knobs, screws, and all other exposed metal parts for AC leakage. Check leakage as described below.

LEAKAGE TEST

The AC leakage from any exposed metal part to earth ground and from all exposed metal parts to any exposed metal part having a return to chassis, must not exceed 3.5 mA. Leakage current can be measured by any one of three methods.

1. A commercial leakage tester, such as the Simpson 229 or RCA WT-540A. Follow the manufacturers' instructions to use these instruments.
2. A battery-operated AC milliammeter. The Data Precision 245 digital multimeter is suitable for this job.
3. Measuring the voltage drop across a resistor by means of a VOM or battery-operated AC voltmeter. The "limit" indication is 5.25 V, so analog meters must have an accurate low-voltage scale. The Simpson 250 and Sanwa SH-63Trd are examples of a passive VOM that is suitable. Nearly all battery operated digital multimeters that have a 20 V AC range are suitable. (See Fig. A)

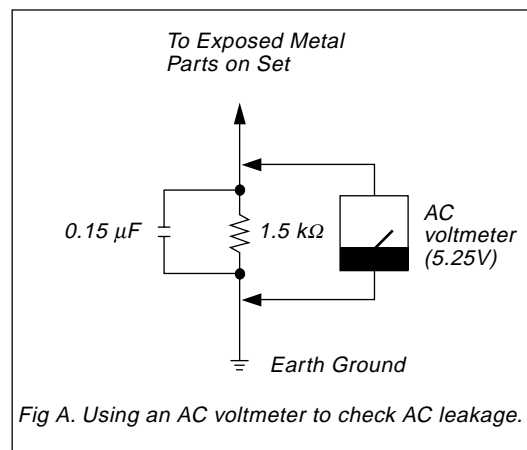

UP-895 (UC)
UP-895CE (CE)
UP-895MD (UC, SY) E
9-955-192-01

Sony Corporation
B&P Company

Printed in Japan
1999. 12 22
©1999