



One Cell Lithium-ion/Polymer Battery Protection IC

■ DESCRIPTION

The UP6006A series product is a high integration solution for lithium-ion/polymer battery protection. UP6006A contains advanced power MOSFET, high-accuracy voltage detection circuits and delay circuits. UP6006A is put into a small package and only one external component makes it an ideal solution in limited space of battery pack. UP6006A has all the protection functions required in the battery application including overcharging, over-discharging, overcurrent and load short circuiting protection etc. The accurate safe and full utilization charging. The low standby current drains little current from the cell while in storage. The device is only targeted for digital cellular phones, but also for any other Li-ion and Li-Poly battery-powered information appliance requiring long-term battery life.

■ FEATURE

- ◆ Protection of Battery Cell Reverse Connection
- ◆ Integrate MOSFET
- ◆ Over-temperature Protection
- ◆ Two-step Overcurrent Detection:
 - Over-discharge Current
 - Load Short Circuiting
- ◆ Charger Detection Function
- ◆ 0V Battery Charging Function
- ◆ High-accuracy Voltage Detection
- ◆ Low Current Consumption
- ◆ Operation Mode: 4uA typ
- ◆ Power-down Mode: 2.0uA typ

■ APPLICATIONS

- ◆ One-Cell Lithium-ion Battery Pack
- ◆ Lithium-Polymer Battery Pack

■ PIN CONFIGURATION

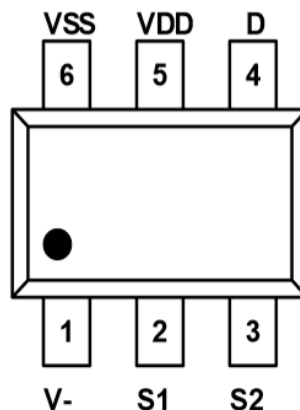



■ PART NUMBER INFORMATION

UP6006A	X=Package Code S:SOT23-6L
---------	------------------------------

■ ORDERING INFORMATION

Part Number	Overcharge Detection Voltage	Overcharge Release Voltage	Overdischarge Detection Voltage	Overdischarge Release Voltage	OverCurrent Detection Current
UP6006AS	4.3	4.1	2.4	3.0	3.2

■ ABSOLUTE MAXIMUM RATINGS ($T_A = 25^\circ\text{C}$ Unless otherwise noted)

Symbol	Parameter	Typical	Unit
V_{DD}	Supply Voltage	-0.3~6	V
V_-	Input Pin Voltage	-6~8	V
T_J	Operation Junction Temperature	150	$^\circ\text{C}$
T_{STG}	Storage Temperature Range	-55~+125	$^\circ\text{C}$
T_{OPR}	Operation Temperature	-40~+80	$^\circ\text{C}$

Note: Absolute maximum ratings are those values beyond which the device could be permanently damaged. Absolute maximum ratings are stress rating only and functional device operation is not implied

■ THERMAL DATA

Symbol	Parameter	Package	Max	Unit
$R_{\theta JA}$	Thermal Resistance-Junction to Ambient	SOT23-6L	200	$^\circ\text{C}/\text{W}$
P_D	Power Dissipation	SOT23-6L	0.3	W



■ **ELECTRICAL CHARACTERISTICS** ($T_A=25\text{ }^\circ\text{C}$ Unless otherwise noted)

Symbol	Parameter	Condition	Min	Typ	Max	Unit
Detection Voltage						
V_{CU}	Overcharge Detection Voltage		$V_{CU}-0.05$	V_{CU}	$V_{CU}+0.05$	V
V_{CL}	Overcharge Release Voltage		$V_{CL}-0.05$	V_{CL}	$V_{CL}+0.05$	V
V_{DL}	Overdischarge Detection Voltage		$V_{DL}-0.1$	V_{DL}	$V_{DL}+0.1$	V
V_{DR}	Overdischarge Release Voltage		$V_{DR}-0.1$	V_{DR}	$V_{DR}+0.1$	V
V_{CHA}	Charger Detection Voltage			-0.12		V
Detection Current						
I_{IOV}	Overdischarge Current Detection	$V_{DD}=3.5V$	2.1	3	3.9	A
I_{SHORT}	Load Short-Circuiting Detection	$V_{DD}=3.5V$	8	12	16	A
Current Consumption						
I_{OPE}	Current Consumption in Normal Operation	$V_{DD}=3.5V$ $V_M=0V$		4	6	μA
I_{PDN}	Current Consumption in Power Down	$V_{DD}=2.0V$ V_M pin floating		2	3.5	μA
VM Internal Resistance						
* R_{VMD}	Internal Resistance Between VM and VDD	$V_{DD}=3.5V$ $V_M=1.0V$		320		$k\Omega$
* R_{VMS}	Internal Resistance Between VM and GND	$V_{DD}=2.0V$ $V_M=1.0V$		100		$k\Omega$
FET on Resistance						
* $R_{SS(ON)}$	Equivalent FET on Resistance	$V_{DD}=3.6V$ $I_{VM}=1.0A$	35	45	55	$m\Omega$
Over Temperature Protection						
* T_{SHD+}	Over Temperature Protection			120		$^\circ C$
* T_{SHD-}	Over Temperature Recovery Degree			100		$^\circ C$
Detection Delay Time						
t_{CU}	Overcharge Voltage Detection Delay Time			140	200	mS
t_{DL}	Overdischarge Voltage Detection Delay Time			80	150	mS
* t_{IOV}	Overdischarge Current Detection Delay Time			4	10	mS
* t_{SHORT}	Load Short-Circuiting Detection Delay Time			10	20	μS

Note: * The parameter is guaranteed by design



■ TYPICAL APPLICATION

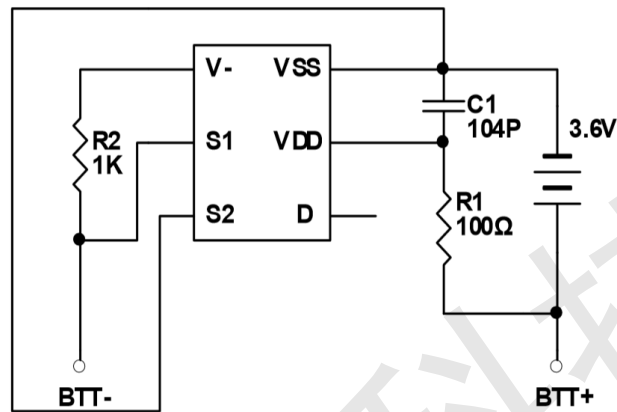

矽源特科技
ChipSourceTek



■ PACKAGE DIENSIONS

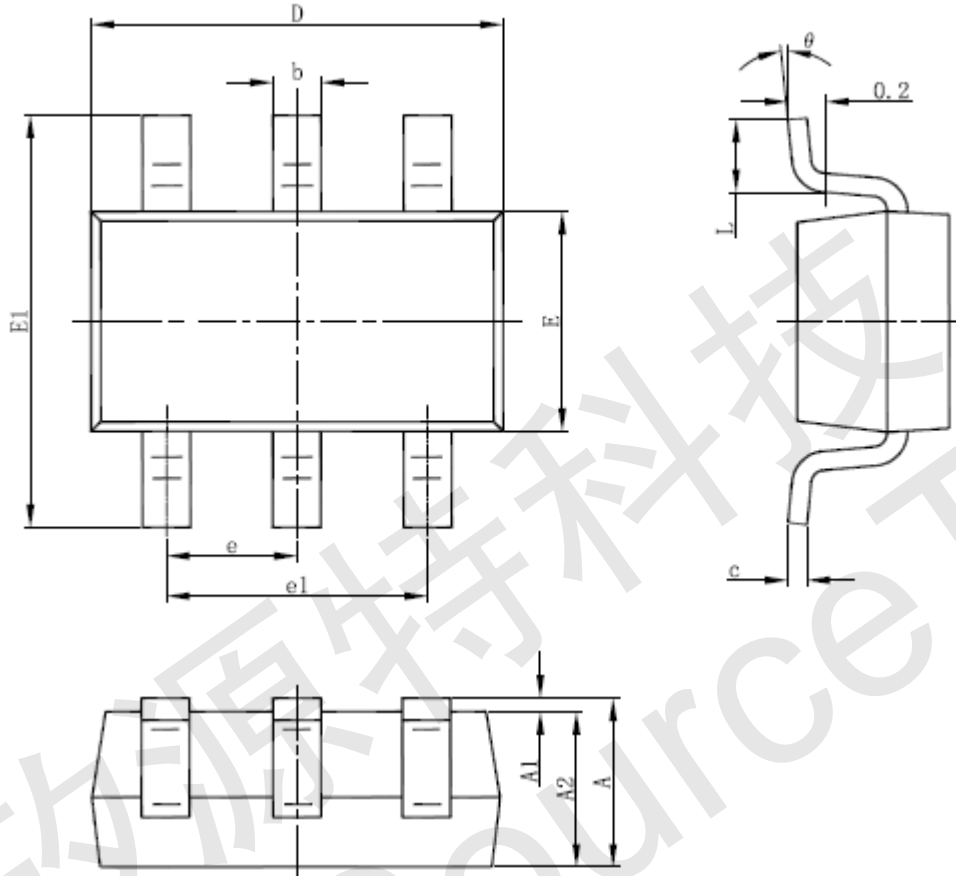

Symbol	Dimensions In Millimeters		Dimensions In Inches	
	Min	Max	Min	Max
A	1.050	1.250	0.041	0.049
A1	0.000	0.100	0.000	0.004
A2	1.050	1.150	0.041	0.045
b	0.300	0.500	0.012	0.020
c	0.100	0.200	0.004	0.008
D	2.820	3.020	0.111	0.119
E	1.500	1.700	0.059	0.067
E1	2.650	2.950	0.104	0.116
e	0.950(BSC)		0.037(BSC)	
e1	1.800	2.000	0.071	0.079
L	0.300	0.600	0.012	0.024
θ	0°	8°	0°	8°



■ SOLDERING METHODS FOR UNIVERCHIP

Storage environment Temperature=10°C~35°C Humidity=65%±15%

Reflow soldering of surface mount device

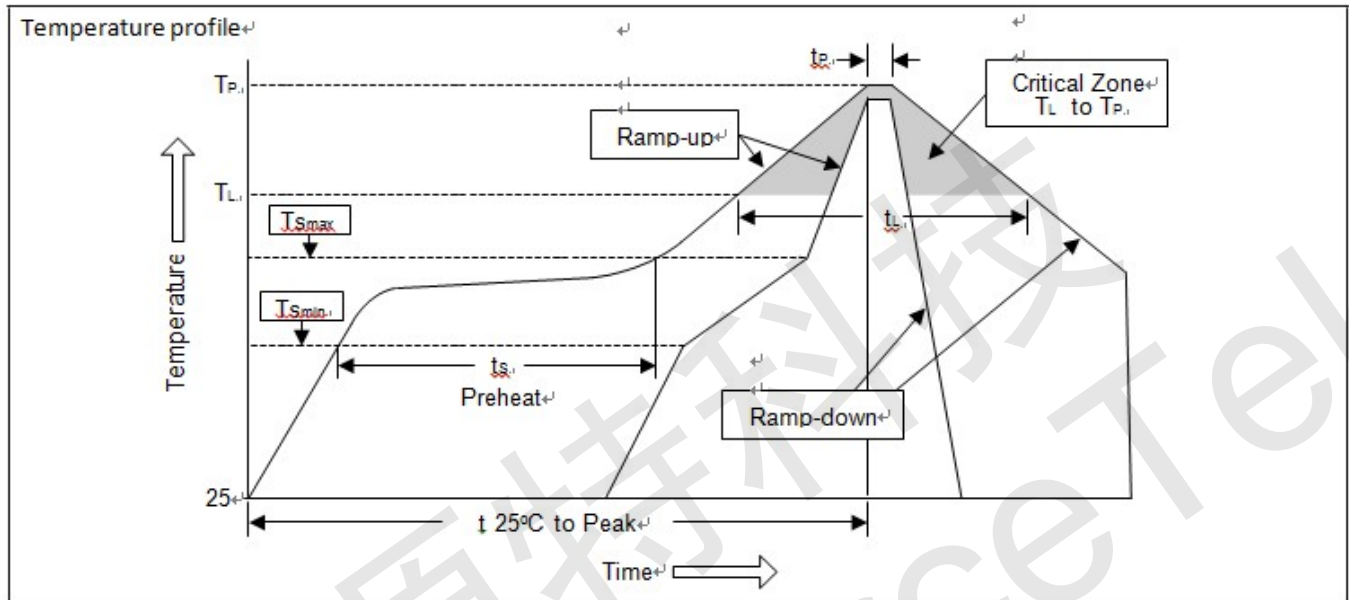

Profile Feature	Sn-Pb Eutectic Assembly	Pb free Assembly
Average ramp-up rate (T _L to T _P)	<3°C/sec	<3°C/sec
Preheat		
-Temperature Min (T _{Smin})	100°C	150°C
-Temperature Max (T _{Smax})	150°C	200°C
-Time (min to max) (t _s)	60~120 sec	60~180 sec
T _{Smax} to T _L		
-Ramp-up Rate	<3°C/sec	<3°C/sec
Time maintained above		
-Temperature (T _L)	183°C	217°C
-Time (t _L)	60~150 sec	60~150 sec
Peak Temperature (T _P)	240°C+0/-5°C	260°C+0/-5°C
Time within 5°C of actual Peak Temperature (t _p)	10~30 sec	20~40 sec
Ramp-down Rate	<6°C/sec	<6°C/sec
Time 25°C to Peak Temperature	<6 minutes	<6 minutes



深圳市矽源特科技有限公司

ShenZhen ChipSourceTek Technology Co. ,Ltd.



Product	Peak Temperature	Dipping Time
Pb device	245°C±5°C	5sec±1sec
Pb-Free device	260°C+0/-5°C	5sec±1sec



This integrated circuit can be damaged by ESD. UniverChip Corporation recommends that all integrated circuits be handled with appropriate precautions. Failure to observe proper handling and installation procedure can cause damage. ESD damage can range from subtle performance degradation to complete device failure. Precision integrated circuits may be more susceptible to damage because very small parametric changes could cause the device not to meet its published specifications.

矽源特科技
ChipSourceTek

TEL: +86-0755-27595155 27595165

FAX: +86-0755-27594792

WEB: [Http://www.ChipSourceTek.com](http://www.ChipSourceTek.com)

E-mail: Tony.Wang@ChipSourceTek.com InFo@ChipSourceTek.com