

20V, 2A Step-Down DC/DC Regulator

FEATURES

- High Efficiency: Up to 93%
- 2A Output Current
- 4.75V to 20V Input Voltage Range
- Fixed 390KHz Frequency
- 0.2Ω Internal Power MOSFET Switch
- 20μA Quiescent Current at Shutdown Mode
- Thermal Shutdown
- Cycle-by-Cycle Over-current Protection
- Output Adjustable from 0.92V to 16V
- Stable with Low ESR Output Ceramic Capacitors
- Available in SOP-8 and MSOP-10 Package with Exposed Pad

APPLICATIONS

- Portable Devices
- LCD Monitors
- Automobile Application
- Battery Charger
- Distributed Power Systems

GENERAL DESCRIPTIONS

The UP9523 is a high efficiency DC/DC buck regulator with a built-in power MOSFET. It can conduct 2A continuous output current over a wide input supply range from 4.75V to 20V with excellent load and line regulation. The output is adjustable down to 0.92V.

The UP9523 operates in current mode which provides fast transient response, easy compensation and cycle-by-cycle current limiting.

The UP9523 will shutdown when the temperature is over 160°C. It folds the PWM frequency down to 75KHz when the output is shorted.

In shutdown mode the regulator draws 20μA of supply current.

The UP9523 comes with SOP-8 and MSOP-10 package with exposed pad and is rated over -40°C and 85°C ambient temperature range.

TYPICAL APPLICATION CIRCUIT

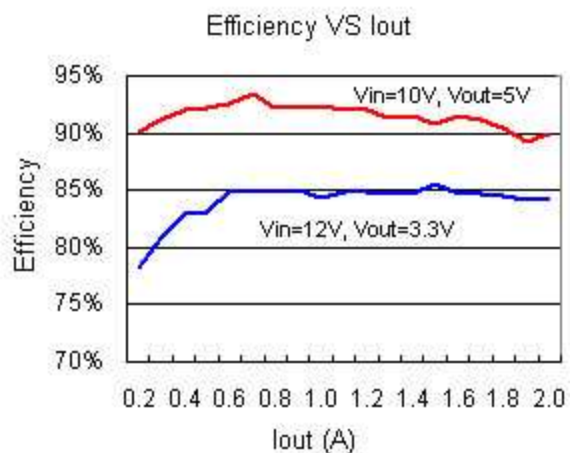
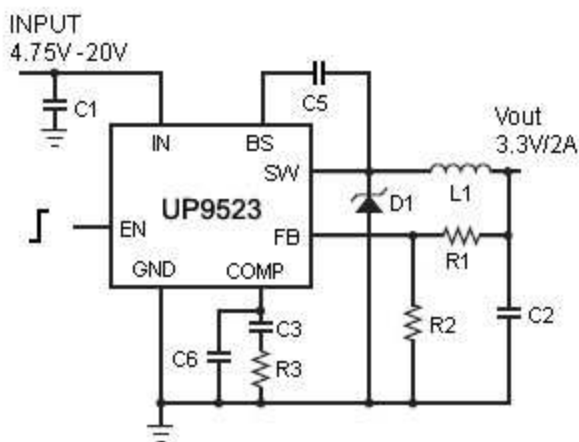

UP9523 – 20V, 2A Step-Down DC/DC Regulator

ORDERING INFORMATION

DEVICE*	PACKAGE	TEMP. RANGE
UP9523CF	SOP-8	-40°C to 85°C

* For Tape & Reel use suffix -T

PIN CONFIGURATION

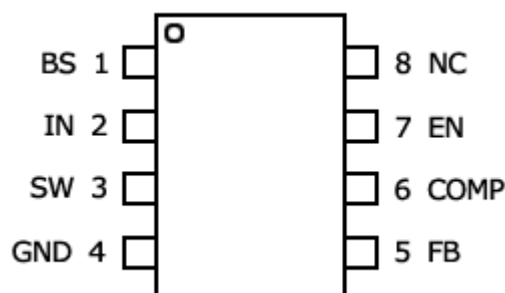

PIN DESCRIPTIONS

PIN NUMBER	PIN NAME	PIN DESCRIPTION
1	BS	Bootstrap. Connect a 10nF or greater ceramic capacitor from BS to SW. The capacitor supplies the gate drive for the upper side switch of the regulator.
2	IN	Power Supply. IN provides the power to the IC, as well as the step-down switcher. Drive IN with a voltage source between 4.75V and 20V. Bypass IN to GND with a suitable capacitor to eliminate the noise on the input to the IC. See Input Capacitor.
3	SW	Power Switch Pin. SW is the switching node that supplies power to the output. Connect the output LC filter from SW to the output load. Note that a capacitor is required from SW to BS to power the upper side switch.
4	GND	Ground.
5	FB	Feedback Input. FB senses through a resistive voltage divider from the output voltage. The feedback threshold is 0.92V. See Setting the Output Voltage.
6	COMP	Compensation Node. COMP is used to compensate the regulation control loop. Connect a series RC network from COMP to GND to compensate the regulation control loop. See Compensation.
7	EN	Enable Input. EN is a digital input that turns the regulator on or off. Drive EN high to turn on the regulator; drive EN low to turn it off. For automatic startup, leave EN unconnected.
8	NC	No Connect.

UP9523 – 20V, 2A Step-Down DC/DC Regulator

ORDERING INFORMATION

DEVICE*	PACKAGE	TEMP. RANGE
UP9523CCP	MSOP-10 with Exposed Pad	-40°C to 85°C

* For Tape & Reel use suffix -T

PIN CONFIGURATION

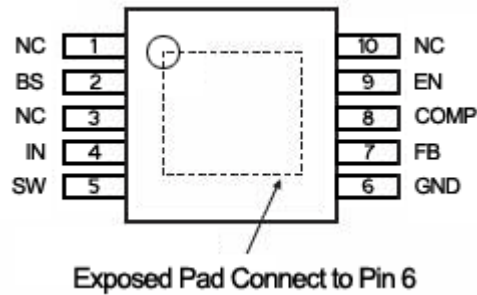

PIN DESCRIPTIONS

PIN NUMBER	PIN NAME	PIN DESCRIPTION
1	NC	No Connect.
2	BS	Bootstrap. Connect a 10nF or greater ceramic capacitor from BS to SW. The capacitor supplies the gate drive for the upper side switch of the regulator.
3	NC	No Connect.
4	IN	Power Supply. IN provides the power to the IC, as well as the step-down switcher. Drive IN with a voltage source between 4.75V and 20V. Bypass IN to GND with a suitable capacitor to eliminate the noise on the input to the IC. See Input Capacitor.
5	SW	Power Switch Pin. SW is the switching node that supplies power to the output. Connect the output LC filter from SW to the output load. Note that a capacitor is required from SW to BS to power the upper side switch.
6	GND	Ground.
7	FB	Feedback Input. FB senses through a resistive voltage divider from the output voltage. The feedback threshold is 0.92V. See Setting the Output Voltage.
8	COMP	Compensation Node. COMP is used to compensate the regulation control loop. Connect a series RC network from COMP to GND to compensate the regulation control loop. See Compensation.
9	EN	Enable Input. EN is a digital input that turns the regulator on or off. Drive EN high to turn on the regulator; drive EN low to turn it off. For automatic startup, leave EN unconnected.
10	NC	No Connect.

ABSOLUTE MAXIMUM RATINGS †

Input Voltage V_{IN}	-0.3V to 30V
SW Pin Voltage V_{SW}	-1V to $V_{IN} + 1V$
Bootstrap Voltage V_{BS}	$V_{SW} - 0.3V$ to $V_{SW} + 6V$
All Other I/O Pin.....	-0.3V to 6V
Operating Ambient Temperature.....	-20°C to 85°C
Maximum Junction Temperature.....	150°C
Package Thermal Resistance θ_{JA} (Note 1)	
SOP-8.....	90°C/W
MSOP-10 with Exposed Pad	105°C/W
Storage Temperature	-65°C to 150°C
Lead Temperature (Soldering, 10 sec).....	260°C

† To prevent permanent damage to the device, do not stress the device beyond these absolute maximum ratings.
(Note 2)

RECOMMENDED OPERATING RATINGS

Input Voltage V_{IN}	4.75V to 20V
------------------------------	--------------

(Note 3)

ELECTRICAL CHARACTERISTICS

($V_{IN} = 12V$, $V_{EN} = 5V$, unless otherwise specified refer to circuit of Figure3. Typical values are at $T_A = 25^\circ C$.)

PARAMETER	SYMBOL	CONDITIONS	MIN	TYP	MAX	UNITS
Feedback Pin Voltage	V_{FB}	$4.75V \leq V_{IN} \leq 20V$	0.893	0.920	0.947	V
Upper Switch On Resistance	R_{ON_UP}			0.2		Ω
Lower Switch On Resistance	R_{ON_LOW}			10		Ω
Upper Switch Leakage	I_{LEAK}	$V_{EN} = 0V$, $V_{SW} = 0V$			10	μA
Current Limit	I_{LIMIT}		2.4	2.8		A
Oscillator Frequency	F_{OSC}		330	390	450	KHz
Short Circuit Frequency	F_{SC}	$V_{FB} = 0V$		75		KHz
Maximum Duty Cycle	D_{MAX}	$V_{FB} = 0.8V$		90		%
Minimum Duty Cycle	D_{Min}	$V_{FB} = 0.8V$			0	%
Error Amplifier Transconductance	G_{EA}			750		$\mu A/V$
EN Threshold	V_{THR}		0.8	1.1	1.4	V
Under Voltage Lockout Threshold Rising	V_{UVLO}		2.0	2.5	3.0	V
Under Voltage Lockout Threshold Hysteresis	V_{HYS}			200		mV
Shutdown Supply Current	I_{SD}	$V_{EN} = 0V$		20	50	μA
Operating Supply Current	I_{OP}	$V_{EN} = 0V$, $V_{FB} = 1.1V$		1.0		mA
Thermal Shutdown	T_{SD}			160		$^\circ C$

Notes:

1. Measured on 1" square of 1 oz. copper FR4 board.
2. Exceeding the absolute maximum rating may damage the device.
3. The device is not guaranteed to function outside its operating ratings

FUNCTIONAL BLOCK DIAGRAM

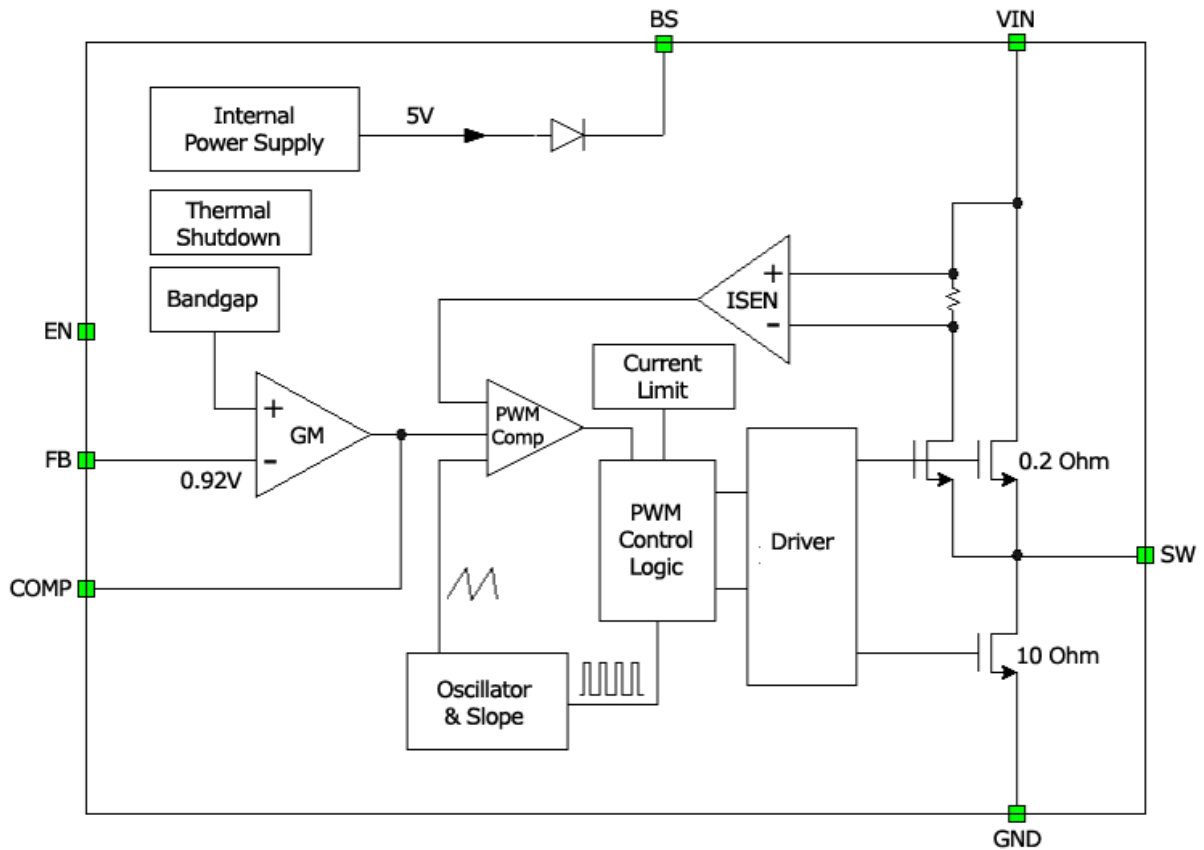

Figure 2. Functional Block Diagram

FUNCTIONAL DESCRIPTION

The UP9523 is a high efficiency DC/DC buck converter. It regulates input voltages from 4.75V to 20V down to a programmable output voltage as low as 0.92V, and is able to supply up to 2A of continuous load current.

The UP9523 uses current-mode PWM control at a fixed frequency of 390KHz. The output voltage is sensed at FB pin through a resistive voltage divider and fed into the internal transconductance error amplifier. The difference of FB and the internal reference (0.92V) is then integrated to get the COMP voltage through an R-C network which also compensates the regulation control system. The COMP voltage is then compared to the signal representing the sensed switch current to get the right PWM.

The converter uses an internal n-channel MOSFET switch to step down the input voltage to the regulated output voltage. Since a gate voltage greater than the input is required, a bootstrap cap is connected between SW and BS to drive the gate of the upper switch. The capacitor is internally charged to 5V while the upper switch is off. An internal 10Ω lower switch from SW to GND is used to insure that SW is pulled to GND when charging the bootstrap capacitor.

The IC will thermal shutdown when the temperature is over 160 °C. When output is shorted, the oscillator will fold its frequency down to 75KHz to protect the IC.

TEST CIRCUIT

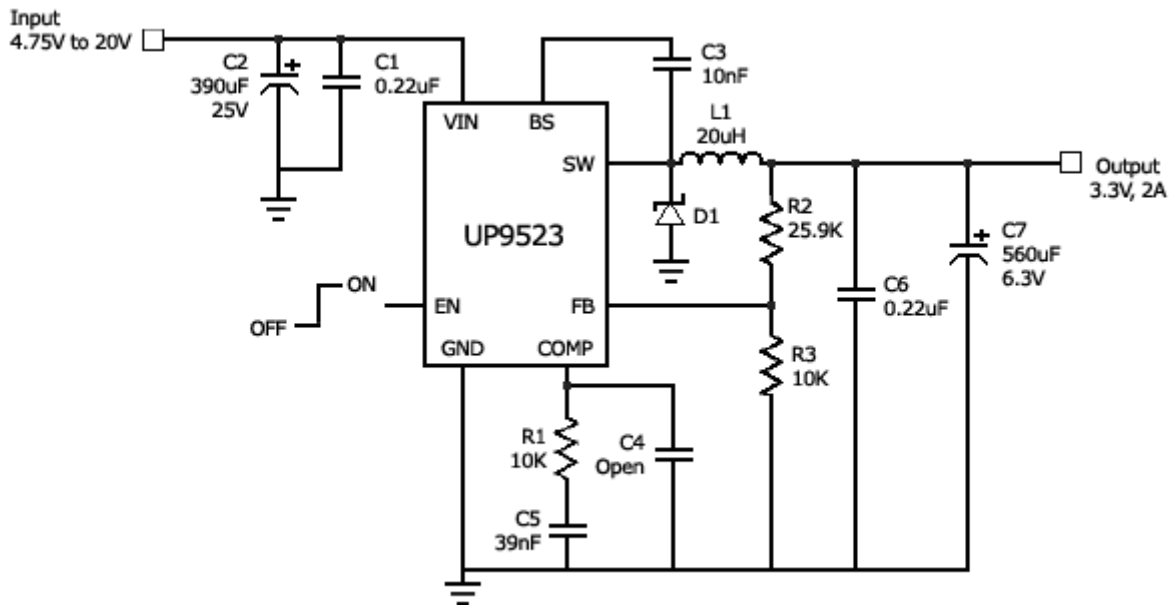

Figure 3. UP9523 Step Down from 20V to 3.3V @2A

APPLICATION INFORMATION

Setting the Output Voltage

A resistive voltage divider from the output to GND (see Figure 3) is used to set the output voltage. The voltage divider divides the output voltage down to FB by the ratio:

$$V_{FB} = V_{OUT} * R3 / (R2 + R3)$$

V_{FB} is internally set at 0.92V. Thus the output voltage is:

$$V_{OUT} = 0.92 * (R2 + R3) / R3$$

If we set $R3 = 10K\Omega$, $R2$ is determined by:

$$R2 \cong 10.87 * (V_{OUT} - 0.92) (K\Omega)$$

For example, for a 3.3V output voltage, $R2$ is 25.9K Ω .

Input Capacitor

An input capacitor $C1$ is required to filter the

noise of the input to the step-down converter. The bypass capacitor should be placed close to the IN pin and GND. A low ESR capacitor is recommended to keep the noise at the IC to a minimum. Ceramic capacitors are preferred, but tantalum or low-ESR electrolytic capacitors may also suffice.

The input capacitor is recommended to be greater than 10 μ F in value with right voltage rating (higher than the input voltage). However since it absorbs the input switching current it requires an adequate ripple current rating. Its RMS current rating should be greater than approximately 1/2 of the DC load current.

Alternatively we could place a small high quality ceramic 0.1 μ F capacitor ($C1$) closer to the IC and a larger capacitor ($C2$) farther away. If using this technique, it is recommended that $C2$ be a tantalum or electrolytic type. All ceramic capacitors should be placed close to the IC.

Output Capacitor

The output capacitor together with the inductor

serves as filter to maintain the DC output voltage. Increasing the output capacitance will lower the output ripple and improve load transient response but increase the solution size and cost. The characteristics of the output capacitor also affect the stability of the regulation control system. Low ESR capacitors are preferred to keep the output voltage ripple low. Ceramic, tantalum, or low ESR electrolytic capacitors are recommended. In the case of ceramic capacitors, the output voltage ripple is mostly independent of the ESR and can be estimated to be:

$$V_{\text{RIPPLE}} \cong 1.4 * V_{\text{IN}} * (f_{\text{LC}} / f)^2$$

Where V_{RIPPLE} is the output ripple voltage, V_{IN} is the input voltage, f_{LC} is the resonant frequency of the LC filter, f is the switching frequency. In the case of tantalum or low-ESR electrolytic capacitors, the ESR dominates the impedance at the switching frequency, and so the output ripple is calculated as:

$$V_{\text{RIPPLE}} \cong \Delta I * R_{\text{ESR}}$$

Where ΔI is the inductor ripple current, and R_{ESR} is the equivalent series resistance of the output capacitors.

The alternative method used for input capacitor can also be applied here, with a small high quality ceramic cap close to the IC and a tantalum or electrolytic cap next to it.

Inductor Selection

The selection of the inductor is determined by the following factors: (a) inductance; (b) rated current value; (c) size requirement; (d) DC resistance (DCR). Increasing the value of the inductor can reduce ripple current but increase the physical size, DCR, and/or lower saturation current. To allow the peak-to-peak ripple current in the inductor to be approximately 30% of the maximum load current, we can determine the inductance by:

$$L = V_{\text{OUT}} * (V_{\text{IN}} - V_{\text{OUT}}) / (V_{\text{IN}} * f * \Delta I)$$

Also make sure the peak current of inductor is less than the current limit.

$$I_{\text{PEAK}} = I_{\text{LOAD}} + \Delta I / 2$$

Schottky Diode Selection

Schottky diode is used to supply current when the upper switch is off. The following factors should be considered: (a) maximum reverse voltage rating higher than input voltage; (b) current rating higher than load current; (c) forward voltage which affects the efficiency.

Compensation

The system stability is compensated through the COMP pin. A series R-C network connected to COMP provides a pole-zero pair to stabilize the system.

The DC loop gain is:

$$A_{\text{VDC}} = (V_{\text{FB}} / V_{\text{OUT}}) * A_{\text{VEA}} * G_{\text{CS}} * R_{\text{LOAD}}$$

Where:

V_{FB} is the feedback threshold voltage, 0.92V.

V_{OUT} is the desired output regulation voltage.

A_{VEA} is the transconductance error amplifier voltage gain, 400 V/V.

G_{CS} is the current sense gain, (roughly the output current divided by the voltage at COMP), 1.95 A/V.

R_{LOAD} is the load resistance (or $V_{\text{OUT}} / I_{\text{OUT}}$ where I_{OUT} is the output load current)

The dominant pole of the system is due to the compensation capacitor (C5):

$$f_{\text{P1}} = G_{\text{EA}} / (2\pi * A_{\text{VEA}} * C5)$$

where G_{EA} is the EA transconductance (750 μ A/V).

The second pole is due to the output:

$$f_{\text{P2}} = 1 / (2\pi * R_{\text{LOAD}} * C7)$$

The zero of importance is introduced to the system by the compensation capacitor (C5) and the compensation resistor (R1):

$$f_{\text{Z1}} = 1 / (2\pi * R1 * C5)$$

If a large value capacitor (C7) with relatively high ESR is used, the zero due to the capacitance and ESR of the output capacitor can be compensated by a third pole set by R1 and C4. The third pole is then located at:

$$f_{p3} = 1/(2\pi * R1 * C4)$$

The system crossover frequency (the frequency where the loop gain drops to 1 or 0dB) is set to approximately 1/10 of the switching frequency.

In this case, the switching frequency is 390KHz, therefore use a crossover frequency, f_c , of 40KHz. Lower crossover frequencies result in slower response and worse transient load recovery. Higher crossover frequencies can result in instability.

Steps to Choose Compensation Components

Step 1. Choose the compensation resistor to set the desired crossover frequency.

Determine R1 by the following equation:

$$R1 = 2\pi * C7 * V_{OUT} * f_c / (G_{EA} * G_{CS} * V_{FB})$$

If the equation gives R1 greater than 10K, set R1=10KΩ to prevent output overshoot at startup. This will lead to f_c less than the desired 40KHz, and is given by:

$$f_c = R1 * G_{EA} * G_{CS} * V_{FB} / (2\pi * C7 * V_{OUT})$$

Step 2. Choose the compensation capacitor C5 to set the zero to 1/4 of the crossover frequency. This gives:

$$C5 = (0.22 * C7 * V_{OUT}) / R1$$

Step 3. If the ESR zero of the output capacitor is less than four times the crossover frequency:

$$8\pi * C7 * R_{ESR} * f_c \geq 1$$

Or:

$$(7.34 * 10^{-5} * R1 * R_{ESR}) / V_{OUT} \geq 1$$

If this is the case, add the second compensation capacitor. Determine the value by the equation:

$$C4 = C7 * R_{ESR(MAX)} / R1$$

where $R_{ESR(MAX)}$ is the maximum ESR of the output capacitor.

PACKAGE INFORMATION

SOP-8

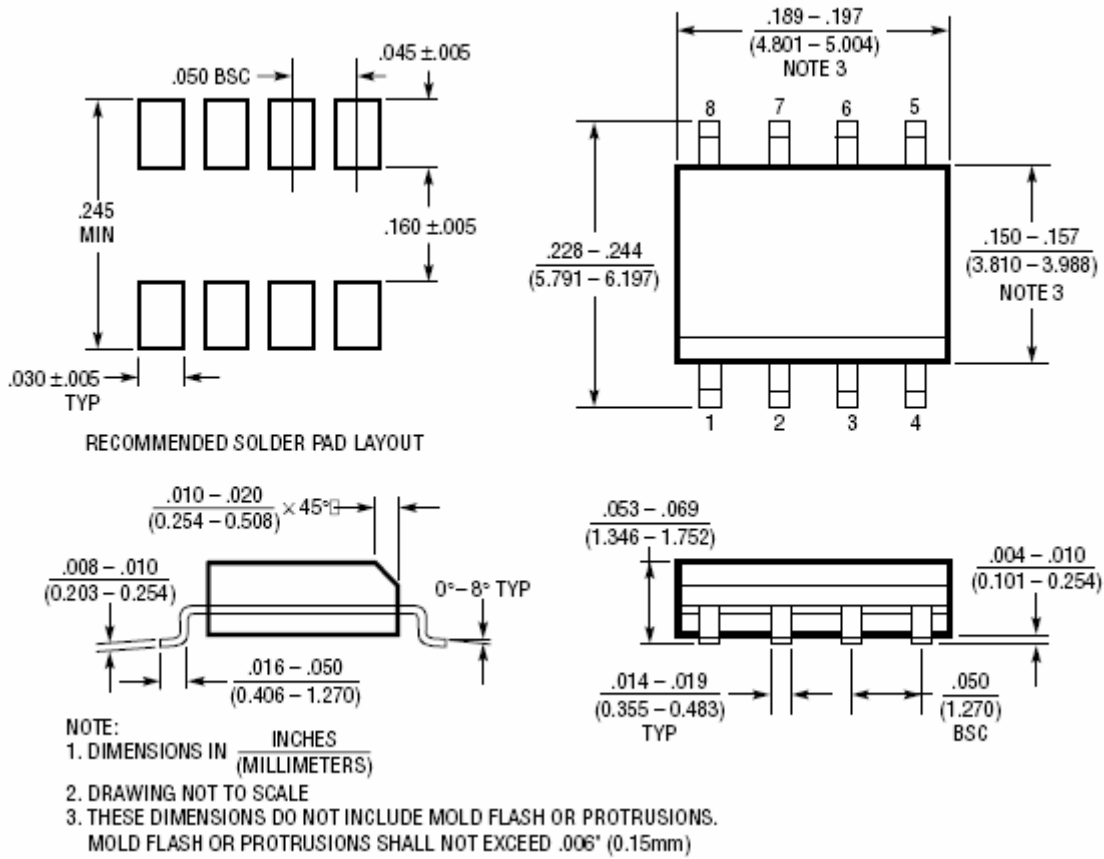

UP9523 – 20V, 2A Step-Down DC/DC Regulator

MSOP-10

10-Lead Plastic MSOP

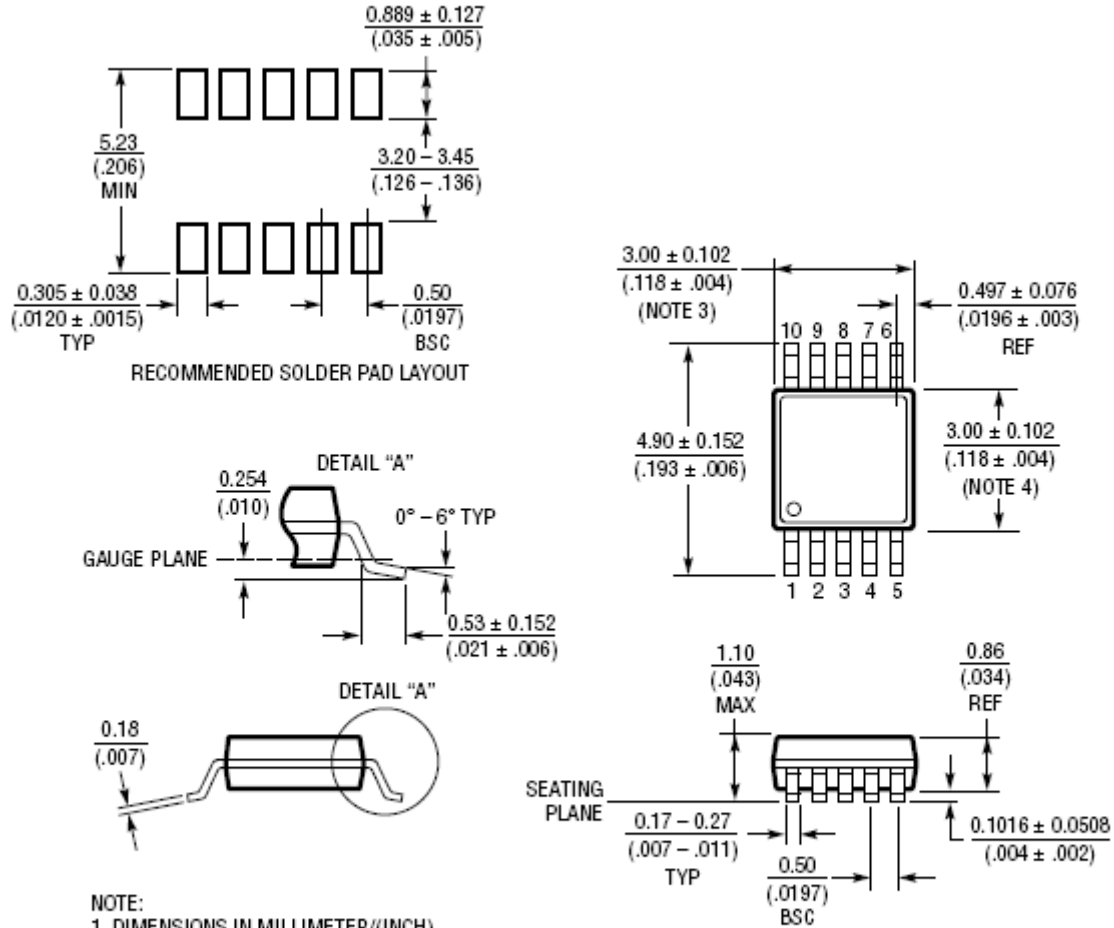

NOTE:

1. DIMENSIONS IN MILLIMETER/(INCH)
2. DRAWING NOT TO SCALE
3. DIMENSION DOES NOT INCLUDE MOLD FLASH, PROTRUSIONS OR GATE BURRS.
MOLD FLASH, PROTRUSIONS OR GATE BURRS SHALL NOT EXCEED 0.152mm (.006") PER SIDE
4. DIMENSION DOES NOT INCLUDE INTERLEAD FLASH OR PROTRUSIONS.
INTERLEAD FLASH OR PROTRUSIONS SHALL NOT EXCEED 0.152mm (.006") PER SIDE
5. LEAD COPLANARITY (BOTTOM OF LEADS AFTER FORMING) SHALL BE 0.102mm (.004") MAX

NOTICE: The information in this document is subject to change without notice. Please contact UPsemi for current specifications. Users should warrant and guarantee the third party intellectual property rights are not infringed upon when integrating UPsemi products into any application. UPsemi will not assume any legal responsibility for any said applications.