

# MOS FIELD EFFECT TRANSISTOR

# $\mu$ PA2211T1M

## P-CHANNEL MOS FET FOR SWITCHING

### DESCRIPTION

The  $\mu$ PA2211T1M is P-channel MOS Field Effect Transistor designed for power management applications of portable equipments, such as load switch.

### FEATURES

- Low on-state resistance  
 $R_{DS(on)1} = 25 \text{ m}\Omega \text{ MAX. (} V_{GS} = -4.5 \text{ V, } I_D = -7.5 \text{ A)}$   
 $R_{DS(on)2} = 34 \text{ m}\Omega \text{ MAX. (} V_{GS} = -2.5 \text{ V, } I_D = -3.8 \text{ A)}$   
 $R_{DS(on)3} = 66 \text{ m}\Omega \text{ MAX. (} V_{GS} = -1.8 \text{ V, } I_D = -3.8 \text{ A)}$
- Built-in gate protection diode
- $-1.8 \text{ V}$  Gate drive available

### ORDERING INFORMATION

PART NUMBER	PACKING	PACKAGE
$\mu$ PA2211T1M-T1-AT <sup>Note</sup>	8 mm embossed taping	8-pin VSOF (1629)
$\mu$ PA2211T1M-T2-AT <sup>Note</sup>	3000 p/reel	0.011 g TYP.

**Note** Pb-free (This product does not contain Pb in external electrode and other parts.)

### PACKAGE DRAWING (Unit: mm)

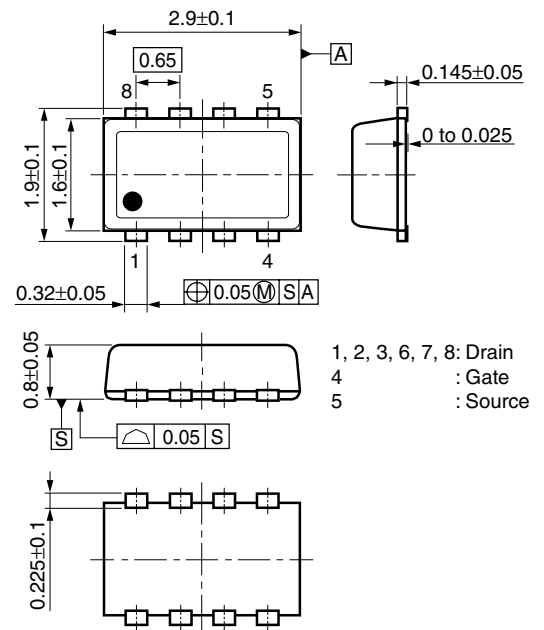

### ABSOLUTE MAXIMUM RATINGS (T<sub>A</sub> = 25°C, All terminals are connected.)

Drain to Source Voltage (V <sub>GS</sub> = 0 V)	V <sub>DSS</sub>	-12	V
Gate to Source Voltage (V <sub>DS</sub> = 0 V)	V <sub>GSS</sub>	±8	V
Drain Current (DC)	I <sub>D(DC)</sub>	±7.5	A
Drain Current (pulse) <sup>Note1</sup>	I <sub>D(pulse)</sub>	±30	A
Total Power Dissipation <sup>Note2</sup>	P <sub>T1</sub>	1.1	W
Total Power Dissipation (PW = 5 sec) <sup>Note2</sup>	P <sub>T2</sub>	2.5	W
Channel Temperature	T <sub>ch</sub>	150	°C
Storage Temperature	T <sub>stg</sub>	-55 to +150	°C

- Notes 1.** PW ≤ 10 μs, Duty Cycle ≤ 1%  
**2.** Mounted on glass epoxy board of 25.4 mm x 25.4 mm x 0.8 mm

**Remark** The diode connected between the gate and source of the transistor serves as a protector against ESD. When this device actually used, an additional protection circuit is externally required if a voltage exceeding the rated voltage may be applied to this device.

The information in this document is subject to change without notice. Before using this document, please confirm that this is the latest version.  
 Not all products and/or types are available in every country. Please check with an NEC Electronics sales representative for availability and additional information.

### EQUIVALENT CIRCUIT

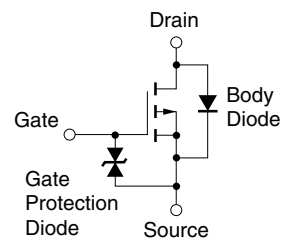

**ELECTRICAL CHARACTERISTICS (TA = 25°C, All terminals are connected.)**

CHARACTERISTICS	SYMBOL	TEST CONDITIONS	MIN.	TYP.	MAX.	UNIT
Zero Gate Voltage Drain Current	I <sub>DSS</sub>	V <sub>DS</sub> = -12 V, V <sub>GS</sub> = 0 V			-10	μA
Gate Leakage Current	I <sub>GSS</sub>	V <sub>GS</sub> = ±8 V, V <sub>DS</sub> = 0 V			±10	μA
Gate to Source Cut-off Voltage	V <sub>GS(off)</sub>	V <sub>DS</sub> = -10 V, I <sub>D</sub> = -1 mA	-0.45		-1.5	V
Forward Transfer Admittance <sup>Note</sup>	y <sub>fs</sub>	V <sub>DS</sub> = -10 V, I <sub>D</sub> = -3.8 A	5			S
Drain to Source On-state Resistance <sup>Note</sup>	R <sub>DS(on)1</sub>	V <sub>GS</sub> = -4.5 V, I <sub>D</sub> = -7.5 A		21	25	mΩ
	R <sub>DS(on)2</sub>	V <sub>GS</sub> = -2.5 V, I <sub>D</sub> = -3.8 A		25	34	mΩ
	R <sub>DS(on)3</sub>	V <sub>GS</sub> = -1.8 V, I <sub>D</sub> = -3.8 A		34	66	mΩ
Input Capacitance	C <sub>iss</sub>	V <sub>DS</sub> = -10 V,		1350		pF
Output Capacitance	C <sub>oss</sub>	V <sub>GS</sub> = 0 V,		255		pF
Reverse Transfer Capacitance	C <sub>rss</sub>	f = 1 MHz		215		pF
Turn-on Delay Time	t <sub>d(on)</sub>	V <sub>DD</sub> = -10 V, I <sub>D</sub> = -3.8 A,		10.7		ns
Rise Time	t <sub>r</sub>	V <sub>GS</sub> = -4.0 V,		16.7		ns
Turn-off Delay Time	t <sub>d(off)</sub>	R <sub>G</sub> = 10 Ω		101.0		ns
Fall Time	t <sub>f</sub>			76.4		ns
Total Gate Charge	Q <sub>G</sub>	V <sub>DD</sub> = -9.6 V,		14.9		nC
Gate to Source Charge	Q <sub>GS</sub>	V <sub>GS</sub> = -4.5 V,		2.8		nC
Gate to Drain Charge	Q <sub>GD</sub>	I <sub>D</sub> = -7.5 A		4.0		nC
Body Diode Forward Voltage <sup>Note</sup>	V <sub>F(S-D)</sub>	I <sub>F</sub> = -7.5 A, V <sub>GS</sub> = 0 V		0.88	1.2	V
Reverse Recovery Time	t <sub>rr</sub>	I <sub>F</sub> = -7.5 A, V <sub>GS</sub> = 0 V,		60		ns
Reverse Recovery Charge	Q <sub>rr</sub>	di/dt = -47 A/μs		19		nC

**Note** Pulsed

**TEST CIRCUIT 1 SWITCHING TIME**

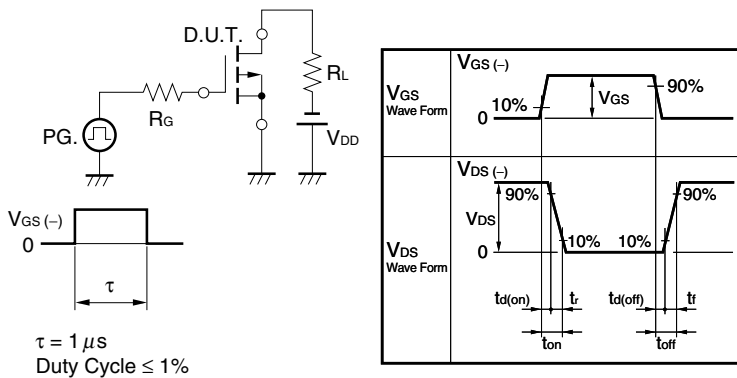

**TEST CIRCUIT 2 GATE CHARGE**

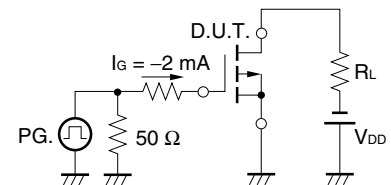

TYPICAL CHARACTERISTICS ( $T_A = 25^\circ\text{C}$ )

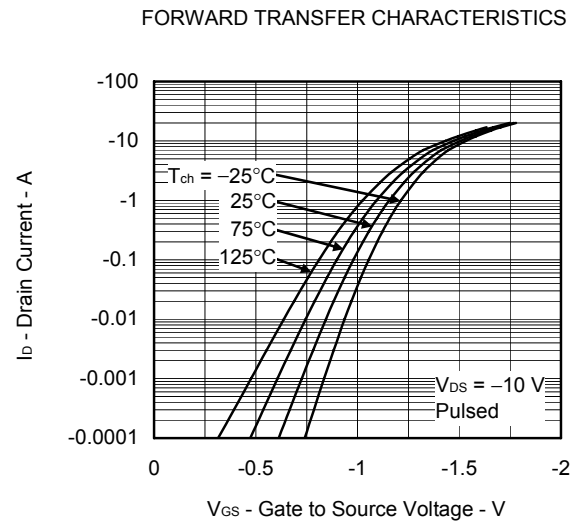
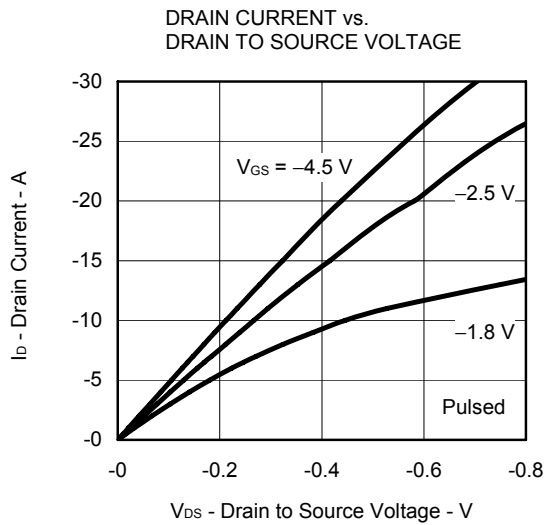
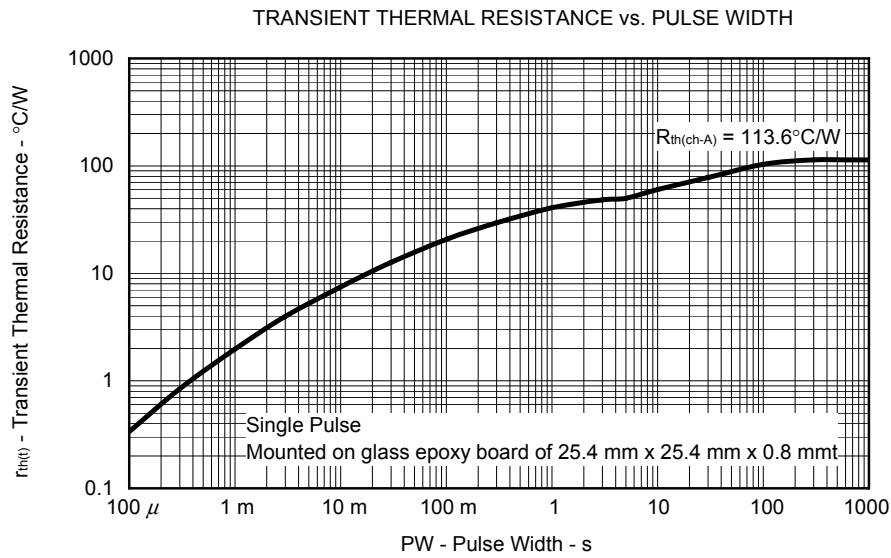
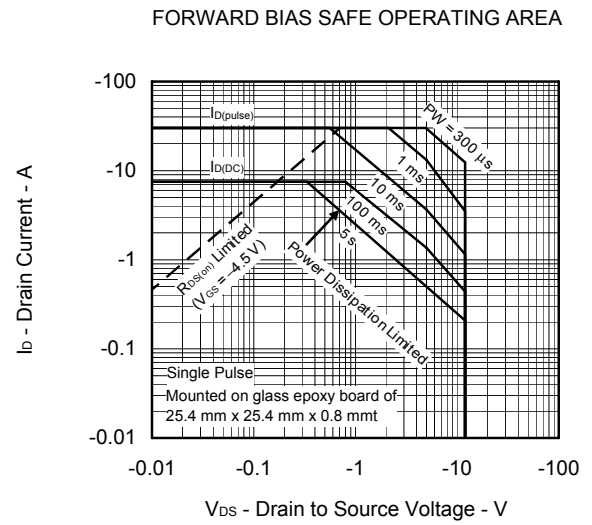
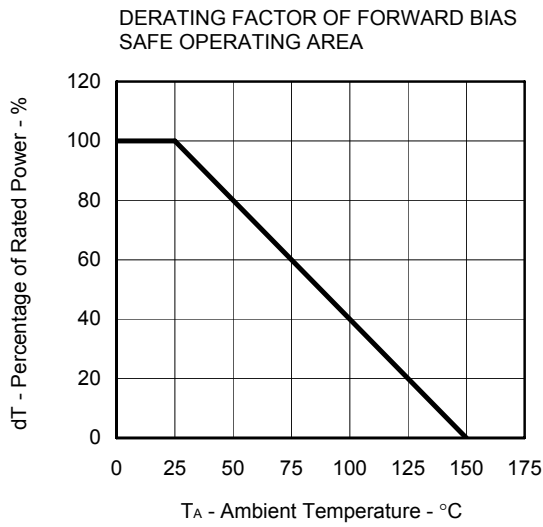

GATE TO SOURCE CUT-OFF VOLTAGE vs. CHANNEL TEMPERATURE

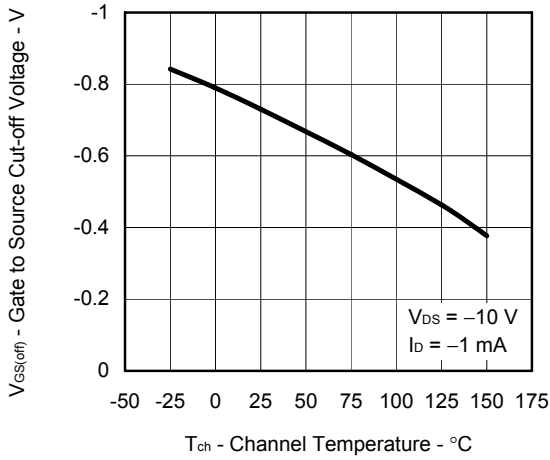

FORWARD TRANSFER ADMITTANCE vs. DRAIN CURRENT

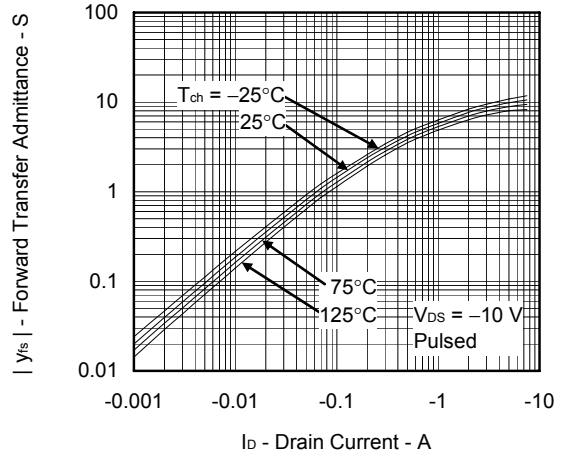

DRAIN TO SOURCE ON-STATE RESISTANCE vs. DRAIN CURRENT

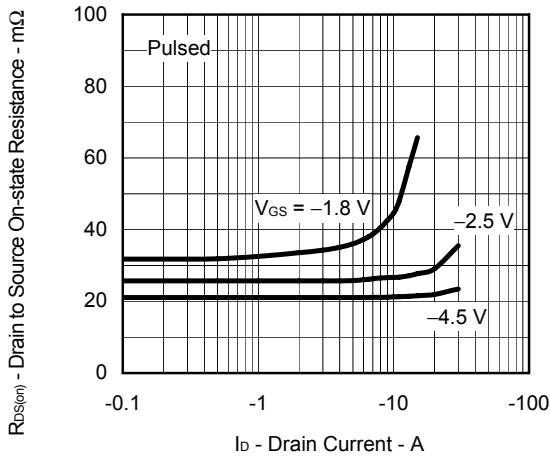

DRAIN TO SOURCE ON-STATE RESISTANCE vs. GATE TO SOURCE VOLTAGE

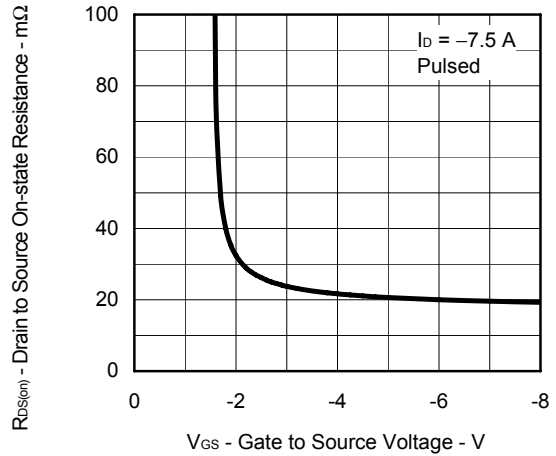

DRAIN TO SOURCE ON-STATE RESISTANCE vs. CHANNEL TEMPERATURE

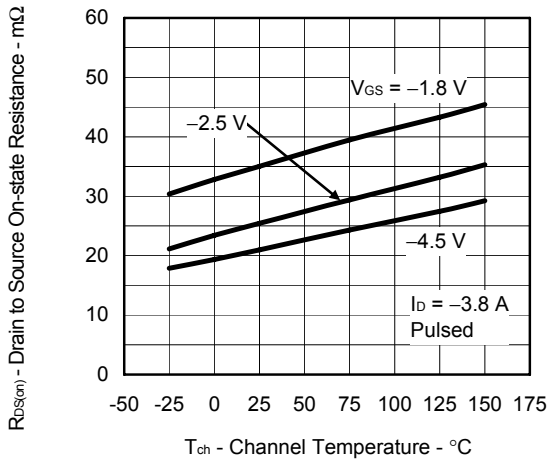

CAPACITANCE vs. DRAIN TO SOURCE VOLTAGE

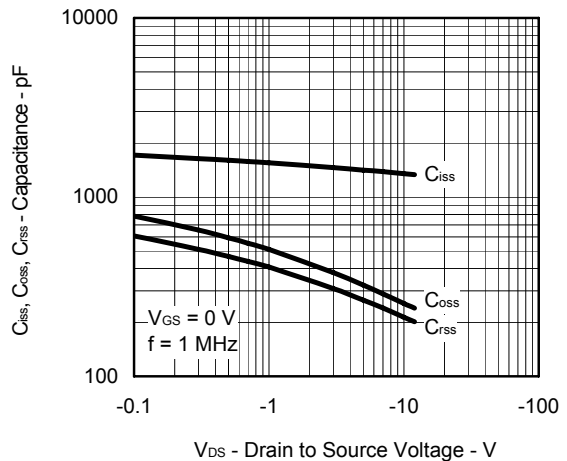

DYNAMIC INPUT/OUTPUT CHARACTERISTICS

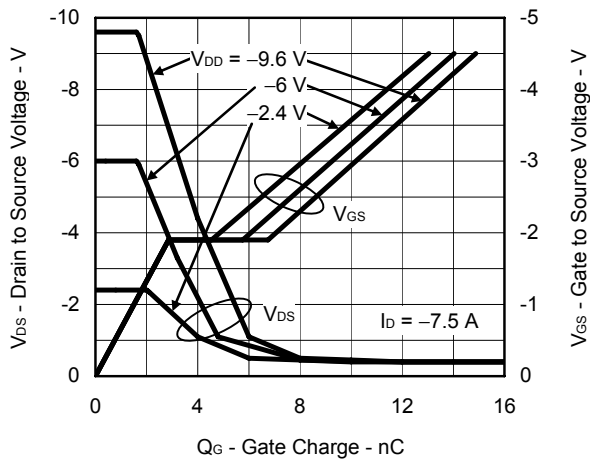

SOURCE TO DRAIN DIODE FORWARD VOLTAGE

