

MOS FIELD EFFECT TRANSISTOR

μ PA2520

N-CHANNEL MOS FET FOR SWITCHING

DESCRIPTION

The μ PA2520 is N-channel MOS Field Effect Transistor designed for DC/DC converter and power management applications of portable equipments.

FEATURES

- Low on-state resistance
 $R_{DS(on)1} = 13.2 \text{ m}\Omega \text{ MAX. (} V_{GS} = 10 \text{ V, } I_D = 10 \text{ A)}$
 $R_{DS(on)2} = 17 \text{ m}\Omega \text{ MAX. (} V_{GS} = 4.5 \text{ V, } I_D = 5.0 \text{ A)}$
- Built-in gate protection diode
- Small and surface mount package (8-pin VSOFF (2429))
- Pb-free (This product does not contain Pb in external electrode and other parts.)

PACKAGE DRAWING (Unit: mm)

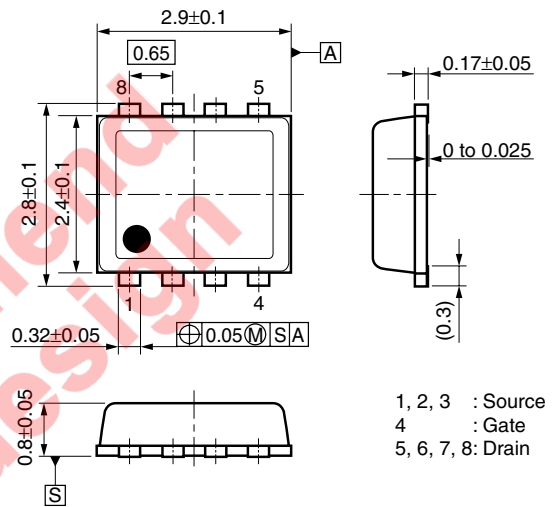

ABSOLUTE MAXIMUM RATINGS (T_A = 25°C, All terminals are connected.)

Drain to Source Voltage (V _{GS} = 0 V)	V _{DSS}	30	V
Gate to Source Voltage (V _{DS} = 0 V)	V _{GSS}	±20	V
Drain Current (DC)	I _{D(DC)}	±10	A
Drain Current (pulse) ^{Note1}	I _{D(pulse)}	±40	A
Total Power Dissipation ^{Note2}	P _{T1}	1.0	W
Total Power Dissipation (PW = 5 sec) ^{Note2}	P _{T2}	2.2	W
Channel Temperature	T _{ch}	150	°C
Storage Temperature	T _{stg}	-55 to +150	°C
Single Avalanche Current ^{Note3}	I _{AS}	10	A
Single Avalanche Energy ^{Note3}	E _{AS}	10	mJ

EQUIVALENT CIRCUIT

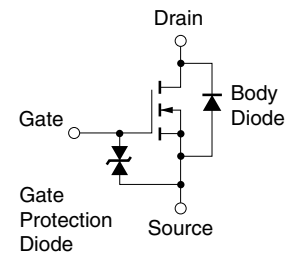

Notes 1. PW ≤ 10 μs, Duty Cycle ≤ 1%

2. Mounted on FR-4 board of 25.4 mm x 25.4 mm x 0.8 mm

3. Starting T_{ch} = 25°C, V_{DD} = 15 V, R_G = 25 Ω, V_{GS} = 20 → 0 V, L = 100 μH

Remark The diode connected between the gate and source of the transistor serves as a protector against ESD. When this device actually used, an additional protection circuit is externally required if a voltage exceeding the rated voltage may be applied to this device.

The information in this document is subject to change without notice. Before using this document, please confirm that this is the latest version.
 Not all products and/or types are available in every country. Please check with an NEC Electronics sales representative for availability and additional information.

ELECTRICAL CHARACTERISTICS (TA = 25°C, All terminals are connected.)

CHARACTERISTICS	SYMBOL	TEST CONDITIONS	MIN.	TYP.	MAX.	UNIT
Zero Gate Voltage Drain Current	I _{DSS}	V _{DS} = 30 V, V _{GS} = 0 V			10	μA
Gate Leakage Current	I _{GSS}	V _{GS} = ±20 V, V _{DS} = 0 V			±10	μA
Gate to Source Cut-off Voltage	V _{GS(off)}	V _{DS} = 10 V, I _D = 1 mA	1.5		2.5	V
Forward Transfer Admittance ^{Note}	y _{fs}	V _{DS} = 10 V, I _D = 5.0 A	4.4			S
Drain to Source On-state Resistance ^{Note}	R _{DS(on)1}	V _{GS} = 10 V, I _D = 10 A		9.4	13.2	mΩ
	R _{DS(on)2}	V _{GS} = 4.5 V, I _D = 5.0 A		12.5	17	mΩ
Input Capacitance	C _{iss}	V _{DS} = 15 V,		1100		pF
Output Capacitance	C _{oss}	V _{GS} = 0 V,		240		pF
Reverse Transfer Capacitance	C _{rss}	f = 1 MHz		88		pF
Turn-on Delay Time	t _{d(on)}	V _{DD} = 15 V, I _D = 5.0 A,		10		ns
Rise Time	t _r	V _{GS} = 10 V,		5.5		ns
Turn-off Delay Time	t _{d(off)}	R _G = 10 Ω		40		ns
Fall Time	t _f			6.2		ns
Total Gate Charge	Q _G	V _{DD} = 15 V,		10.8		nC
Gate to Source Charge	Q _{GS}	V _{GS} = 5 V,		3.3		nC
Gate to Drain Charge	Q _{GD}	I _D = 10 A		3.6		nC
Body Diode Forward Voltage ^{Note}	V _{F(S-D)}	I _F = 10 A, V _{GS} = 0 V		0.82		V
Reverse Recovery Time	t _{rr}	I _F = 10 A, V _{GS} = 0 V,		26		ns
Reverse Recovery Charge	Q _{rr}	di/dt = 100 A/μs		19		nC
Gate Resistance	R _G	f = 1 MHz		1.6		Ω

Note Pulsed

TEST CIRCUIT 1 AVALANCHE CAPABILITY

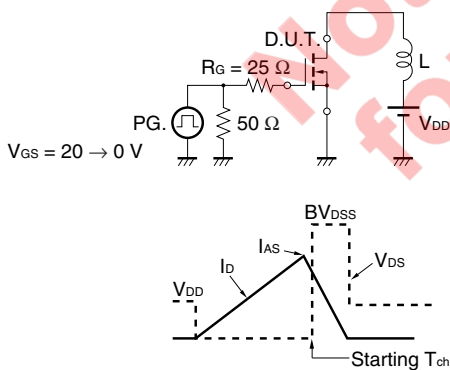

TEST CIRCUIT 2 SWITCHING TIME

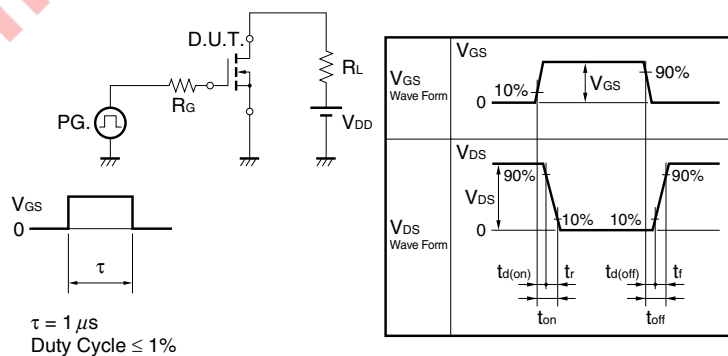

TEST CIRCUIT 3 GATE CHARGE

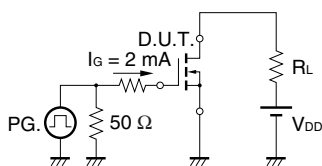

TYPICAL CHARACTERISTICS (T_A = 25°C)

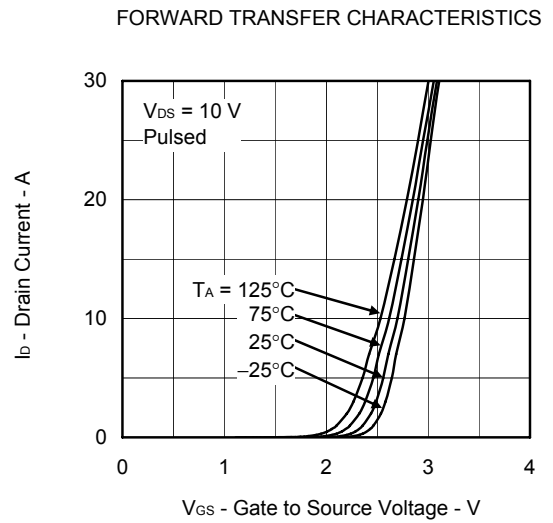
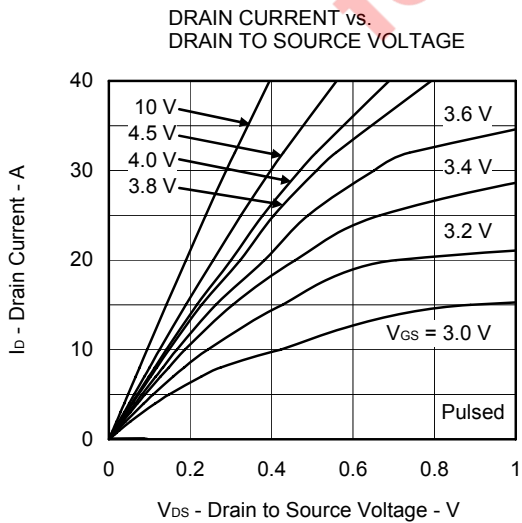
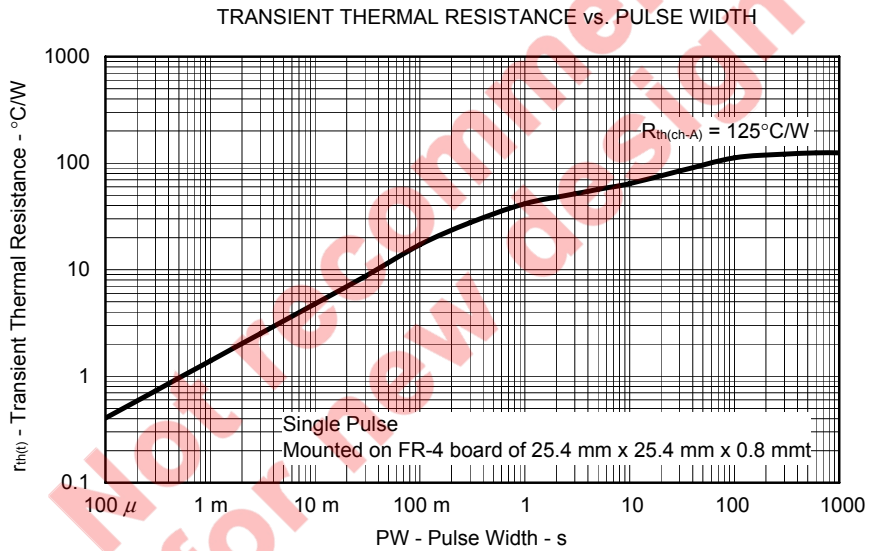
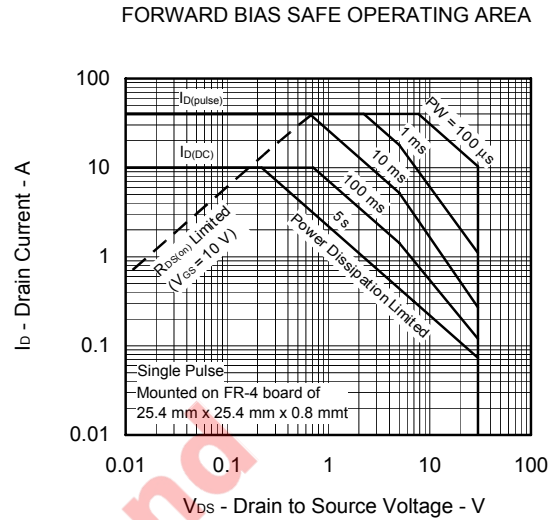
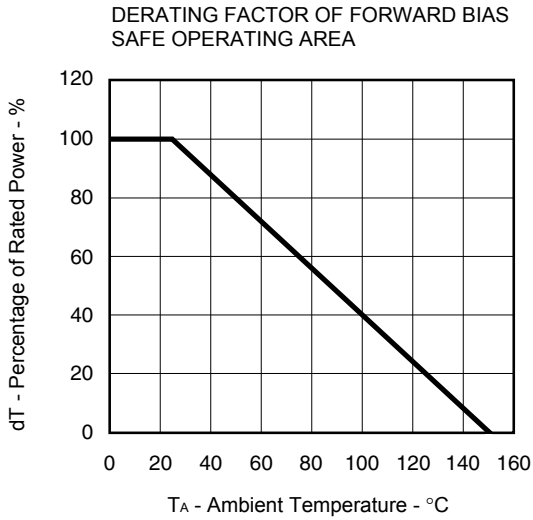

GATE TO SOURCE CUT-OFF VOLTAGE vs. CHANNEL TEMPERATURE

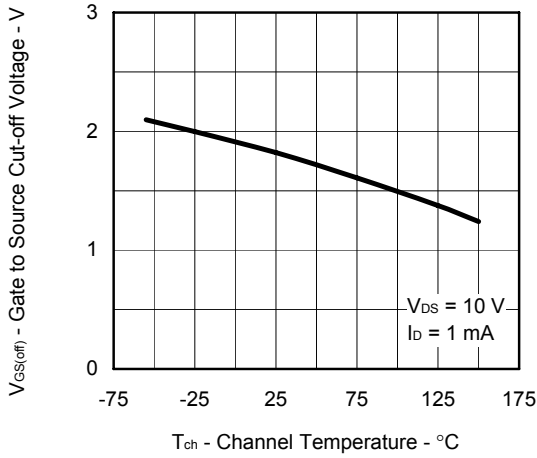

FORWARD TRANSFER ADMITTANCE vs. DRAIN CURRENT

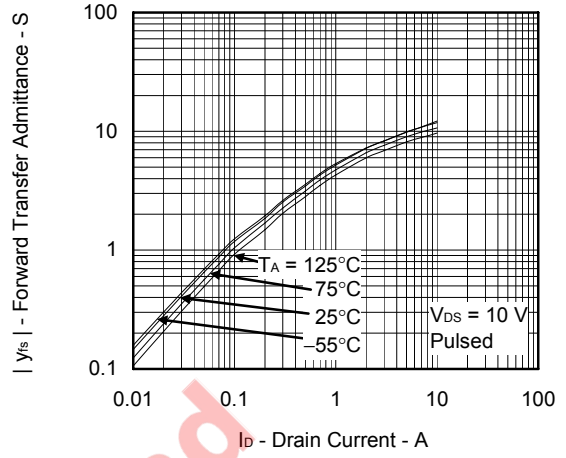

DRAIN TO SOURCE ON-STATE RESISTANCE vs. DRAIN CURRENT

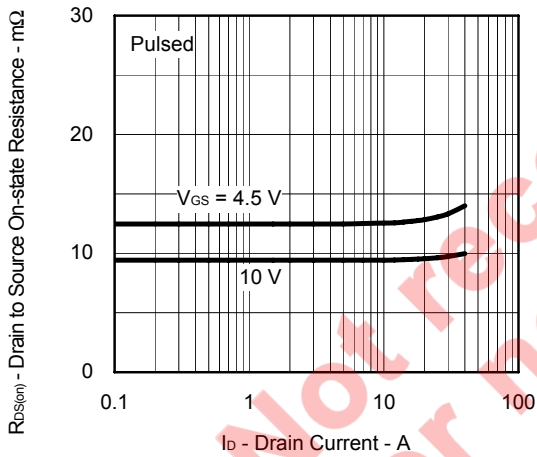

DRAIN TO SOURCE ON-STATE RESISTANCE vs. GATE TO SOURCE VOLTAGE

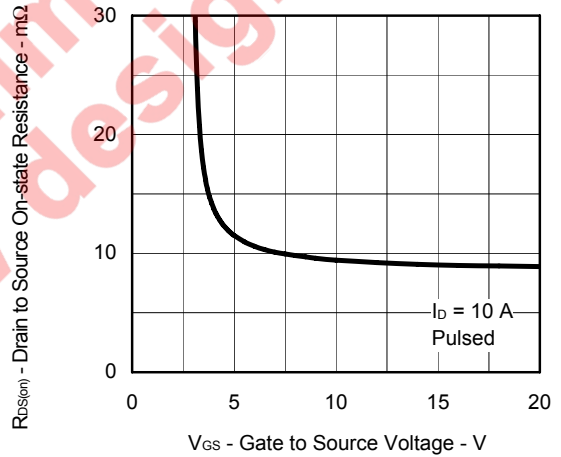

DRAIN TO SOURCE ON-STATE RESISTANCE vs. CHANNEL TEMPERATURE

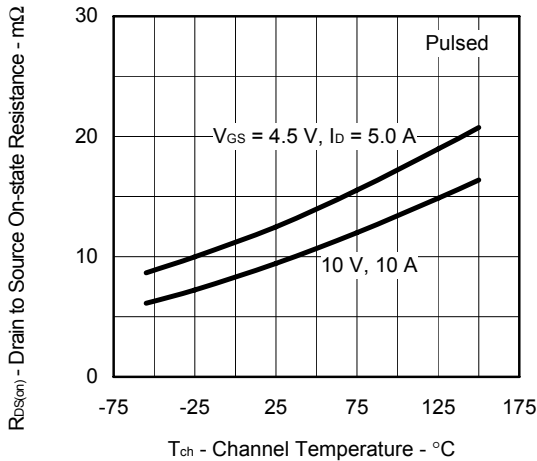

CAPACITANCE vs. DRAIN TO SOURCE VOLTAGE

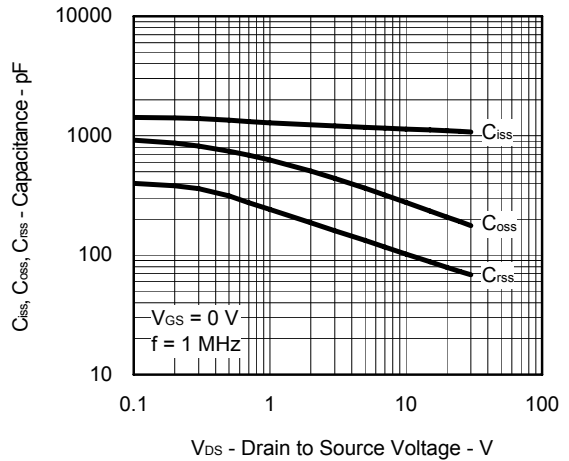

DYNAMIC INPUT CHARACTERISTICS

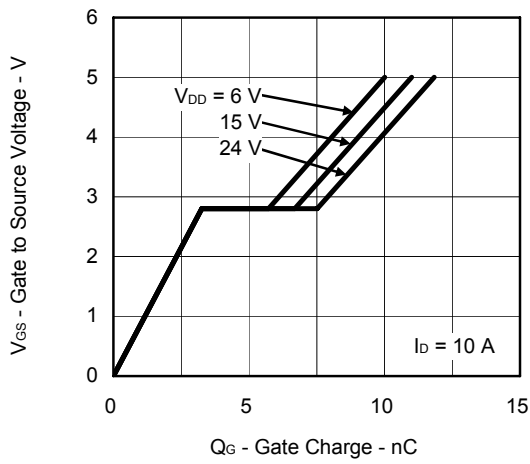

SOURCE TO DRAIN DIODE FORWARD VOLTAGE

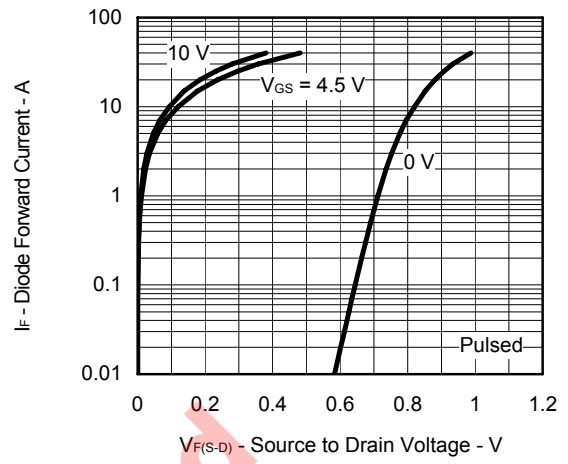

ORDERING INFORMATION

PART NUMBER	LEAD PLATING	PACKING	PACKAGE
μ PA2520T1H-T1-AT ^{Note}	Pure Sn	8 mm embossed taping	8-pin VSOF (2429)
μ PA2520T1H-T2-AT ^{Note}		3000 p/reel	

Note Pb-free (This product does not contain Pb in external electrode and other parts.)

Not recommended for new design