

FEATURES

- HIGH FREQUENCY OPERATION TO 2.5 GHz
- WIDE BAND OPERATION
- SINGLE SUPPLY VOLTAGE: $V_{CC} = 5\text{ V} \pm 10\%$
- AVAILABLE IN TAPE AND REEL (G08 PACKAGE)

DESCRIPTION

The UPB586 series of devices are silicon bipolar prescalers which can be operated in divide-by-256 or divide-by-512 mode. They feature high frequency response and operate from a single 5 volt supply. The series is available in two package styles: 8 lead ceramic flat pack (UPB586B) and an 8 pin plastic mini-flat package (UPB586G). Applications include frequency synthesis, division and scaling.

RECOMMENDED

OPERATING CONDITIONS ($T_A = 25^\circ\text{C}$)

SYMBOL	PARAMETER	UNITS	RATINGS
V_{CC}	Supply Voltage	V	4.5 to 5.5
T_{OP}	Operating Temperature	$^\circ\text{C}$	-20 to +75

TEST CIRCUIT

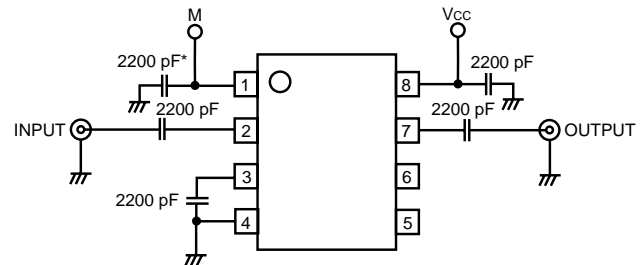

*Not required if M is grounded.

Note: Because of the high internal gain and gain compression of the UPB586, this device is prone to self-oscillation in the absence of an RF input signal. If the device will be used in an application where DC power will be applied in the absence of an RF input signal, this self-oscillation can be suppressed by any of the following means:

- * Add a shunt resistor from the RF input line to ground. The blocking capacitor should be between the resistor and the UPB586, but physical separation should be minimized. Typically a resistor value between 50 and 100 ohms will suppress the self-oscillation.
- * Apply a DC offset voltage of +3.0 volts to the INPUT pin. The voltage source should be isolated from the INPUT pin by a series 1000 ohm resistor.
- * Apply a DC offset voltage of +1.5 volts to the BYPASS pin. The voltage source should be isolated from the BYPASS pin by a series 1000 ohm resistor.

All these approaches reduce the input sensitivity of the UPB586 (by as much as 3 dB for the example of a 50 ohm shunt resistor), but otherwise have no effect on the reliability or other electrical characteristics of this device.

ELECTRICAL CHARACTERISTICS¹ ($T_A = -20$ to $+75^\circ\text{C}$, $V_{CC} = 5\text{ V}$)

PART NUMBER PACKAGE OUTLINE			UPB586B, UPB586G BF08, G08		
SYMBOLS	PARAMETERS AND CONDITIONS	UNITS	MIN	TYP	MAX
I_{CC}	Supply Current, $T_A = 25^\circ\text{C}$	mA	19	28	37
f_{IN}	Frequency Response at $P_{IN} = -15$ to -10 dBm $P_{IN} = -10$ to -5 dBm $P_{IN} = -5$ to $+5$ dBm	GHz GHz GHz	0.5 0.5 1.3		2.3 2.5 2.5
P_{IN}	Input Power at $f_{IN} = 0.5$ to 1.3 GHz $f_{IN} = 1.3$ to 2.3 GHz $f_{IN} = 2.3$ to 2.5 GHz	dBm dBm dBm	-15 -15 -10		-5 +5 +5
P_{OUT}	Power Output at $f_{IN} = 2$ GHz, $P_{IN} = 0$ dBm, $T_A = 25^\circ\text{C}$	dBm	-11	-7	
$R_{TH} (J-C)$	Thermal Resistance, Junction to Case (UPB586B)	$^\circ\text{C}/\text{W}$			50
$R_{TH} (J-A)$	Thermal Resistance, Junction to Ambient (UPB586G) ²	$^\circ\text{C}/\text{W}$			270

Notes:

1. $V_{CC} = 5\text{ V} \pm 10\%$ (unless otherwise noted): $Z_s = Z_o = 50\ \Omega$.
2. Mounted on a $5 \times 5 \times 0.16$ mm epoxy glass circuit board.

UPB586B, UPB586G

ABSOLUTE MAXIMUM RATINGS¹ (T_A = 25°C)

SYMBOLS	PARAMETERS	UNITS	RATINGS
V _{CC}	Supply Voltage	V	-0.5 to 6.0
V _{IN}	Input Voltage	V	-0.5 to V _{CC} + 0.5
P _{IN}	Input Power	dBm	+10
P _D	Power Dissipation UPB586B UPB586G	W mW	1.5 (T _A = +125°C) 250 (T _A = +85°C)
T _{OP}	Operating Temperature UPB586B UPB586G	°C °C	-55 to +125 -40 to +85
T _{STG}	Storage Temperature UPB586B UPB586G	°C °C	-55 to +200 -65 to +150

Note:

1. Operation in excess of any one of these parameters may result in permanent damage.

INTERNAL BLOCK DIAGRAM

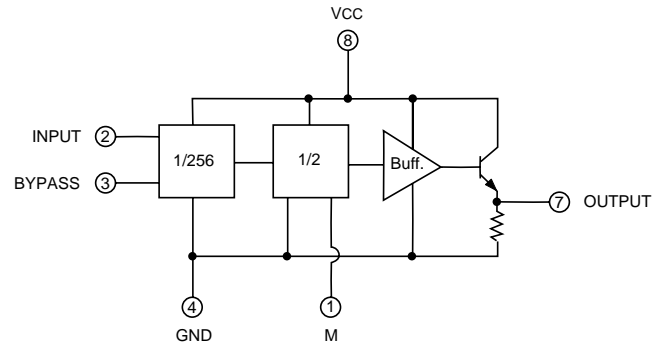

INPUT IMPEDANCE FOR UPB586G

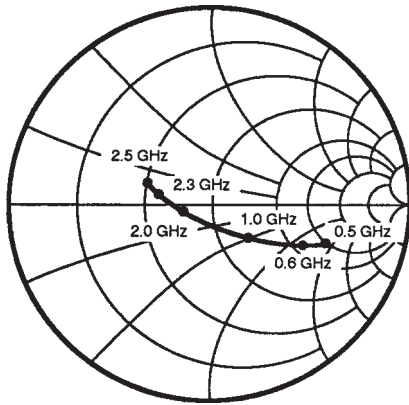

V_{CC} = 5 V, I_C = 28 mA,
Z₀ = 50 Ω

Frequency (GHz)	Z _{IN} (Ω)
0.5	157.9 -j99.9
0.6	136.6 -j79.9
0.8	111.4 -j61.3
1.0	90.1 -j43.4
1.2	74.2 -j29.7
1.4	62.9 -j20.2
1.6	54.0 -j13.7
1.8	45.7 -j8.6
2.0	39.8 -j4.3
2.2	33.8 -j0.1
2.3	31.1 +j1.6
2.5	28.0 +j4.5

UPB586B

INPUT AND OUTPUT S-PARAMETERS

V_{CC} = 5 V, I_{CC} = 28 mA

DIVIDE-BY-256 MODE

Frequency			S ₁₁			Frequency			S ₂₂		
(GHz)	MAG	ANG	(GHz)	MAG	ANG	(GHz)	MAG	ANG	(GHz)	MAG	ANG
0.20	0.768	-14	0.10	0.516	-9						
0.40	0.752	-29	0.20	0.505	-14						
0.60	0.734	-43	0.30	0.501	-20						
0.80	0.715	-57	0.40	0.500	-27						
1.00	0.698	-70	0.50	0.499	-33						
1.20	0.686	-84	0.60	0.495	-40						
1.40	0.663	-98	0.70	0.492	-46						
1.60	0.629	-112	0.80	0.484	-53						
1.80	0.591	-126	0.90	0.479	-59						
2.00	0.547	-139	1.00	0.474	-66						
2.20	0.502	-151									
2.40	0.456	-162									
2.60	0.413	-172									
2.80	0.378	180									
3.00	0.355	171									

DIVIDE-BY-512 MODE

Frequency			S ₁₁			Frequency			S ₂₂		
(GHz)	MAG	ANG	(GHz)	MAG	ANG	(GHz)	MAG	ANG	(GHz)	MAG	ANG
0.20	0.990	-11	0.10	0.495	-9						
0.40	0.978	-21	0.20	0.487	-14						
0.60	0.968	-32	0.30	0.482	-20						
0.80	0.957	-42	0.40	0.482	-26						
1.00	0.947	-52	0.50	0.482	-33						
1.20	0.939	-62	0.60	0.477	-39						
1.40	0.930	-72	0.70	0.476	-46						
1.60	0.916	-82	0.80	0.468	-53						
1.80	0.905	-92	0.90	0.471	-59						
2.00	0.889	-102	1.00	0.458	-65						
2.20	0.871	-112									
2.40	0.854	-121									
2.60	0.832	-130									
2.80	0.812	-139									
3.00	0.795	-144									

TYPICAL PERFORMANCE CURVES (TA = 25°C)

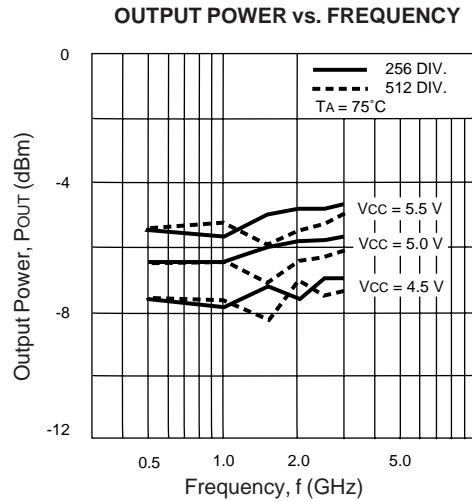
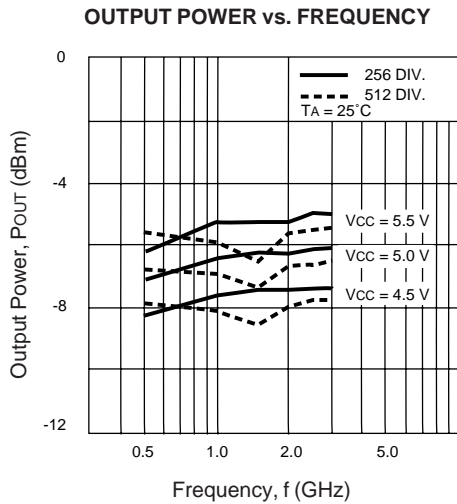
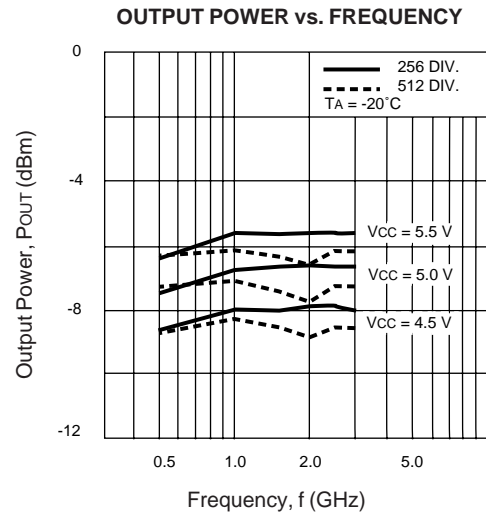
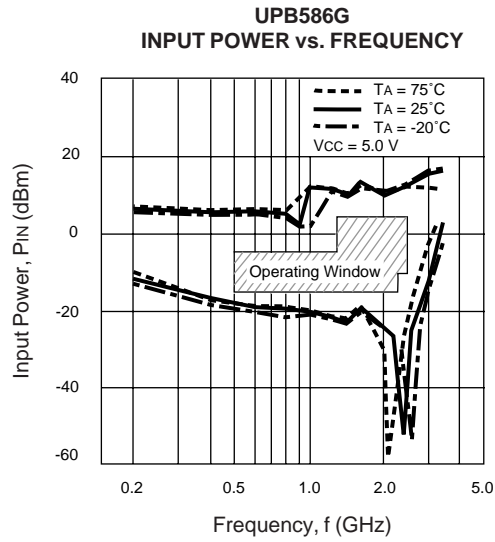
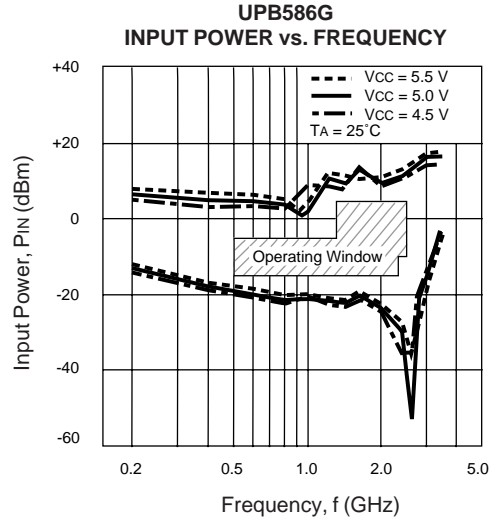
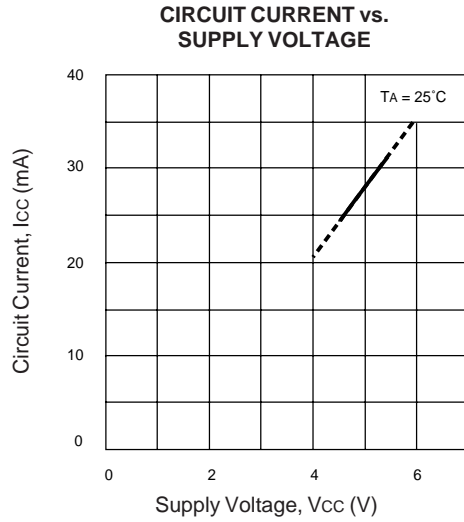

UPB586B, UPB586G

OUTLINE DIMENSIONS (Units in mm)

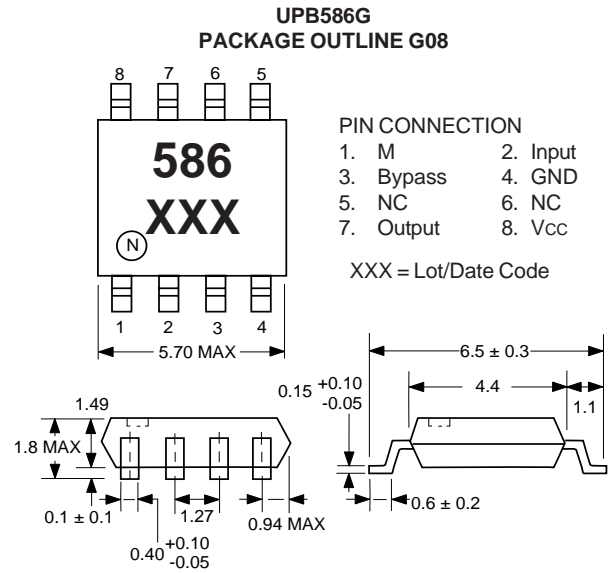
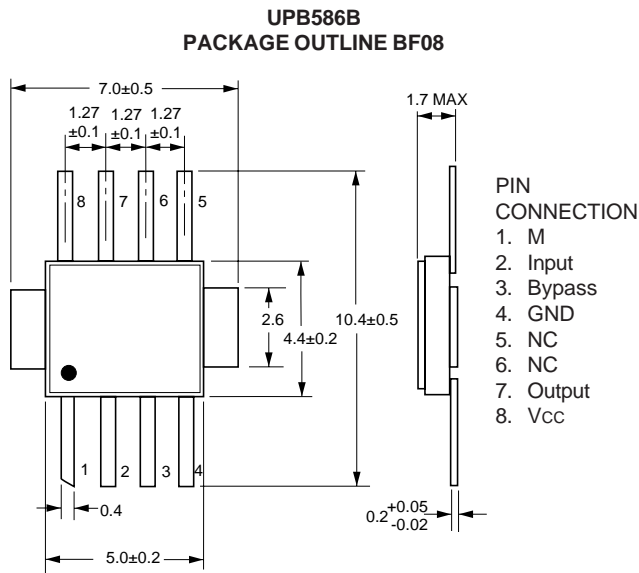

PIN DESCRIPTION

PIN NO.	SYMBOL	DESCRIPTION	
1	M	Division Ratio Control	
		M	Division Ratio
		L (GND)	1/512
		H (Vcc)	1/256
2	INPUT	Signal Input Pin	
3	BYPASS	Input Bypass Pin, shall be connected to ground through bypass connector	
4	GND	Ground Pin	
5	NC	Non Connection	
6	NC	Non Connection	
7	OUTPUT	Output Pin	
8	Vcc	Power Supply	

ORDERING INFORMATION

PART NUMBER	QTY
UPB586G-E1	2500/Reel

EXCLUSIVE AGENT FOR **NEC Corporation** RF & MICROWAVE SEMICONDUCTOR PRODUCTS - U.S. & CANADA

CALIFORNIA EASTERN LABORATORIES, INC • Headquarters • 4590 Patrick Henry Drive • Santa Clara, CA 95054-1817 • (408) 988-3500 • Telex 34-6393/FAX (408) 988-0279
DATA SUBJECT TO CHANGE WITHOUT NOTICE