

BIPOLAR ANALOG INTEGRATED CIRCUIT

μ PC8158K

RF UP-CONVERTER WITH AGC FUNCTION + IF QUADRATURE MODULATOR IC FOR DIGITAL MOBILE COMMUNICATION SYSTEMS

DESCRIPTION

The μ PC8158K is a silicon microwave monolithic integrated circuit designed as quadrature modulator for digital mobile communication systems. This MMIC consists of 0.8 GHz to 1.5 GHz up-converter and 100 MHz to 300 MHz quadrature modulator which are equipped with AGC and power save functions. This configuration suits to IF modulation system. The package is 28-pin QFN suitable for high density mounting. The chip is manufactured using NEC's 20 GHz fr silicon bipolar process NESAT™ III to realize low power consumption. Consequently the μ PC8158K can contribute to make RF blocks smaller size, higher performance and lower power consumption.

FEATURES

- Supply voltage: $V_{cc} = 2.7$ to 4.0 V, $I_{cc} = 28$ mA @ $V_{cc} = 3.0$ V
- Built-in LPF suppresses spurious multiplied by TX local (LO1)
- AGC amplifier is installed in local port of up converter: $GCR = 35$ dB MIN. @ $f_{out} = 1.5$ GHz
- Excellent performance: $P_{adj} = -65$ dBc TYP. @ $\Delta f = \pm 50$ kHz, EVM = 1.2 % rms TYP.
- External IF filter can be applied between modulator output and up converter input terminal.

APPLICATIONS

- Digital cellular phones (PDC800M, PDC1.5G and so on)

ORDERING INFORMATION

Part Number	Package	Supplying Form
μ PC8158K-E1	28-pin plastic QFN ($5.1 \times 5.5 \times 0.95$ mm)	Embossed tape 12 mm wide. Pin 1 is in pull-out direction. QTY 2.5 kp/Reel.

Remark To order evaluation samples, please contact your local NEC sales office. (Part number for sample order: μ PC8158K)

Caution Electro-static sensitive device

The information in this document is subject to change without notice.

INTERNAL BLOCK DIAGRAM AND PIN CONNECTIONS (TOP View)

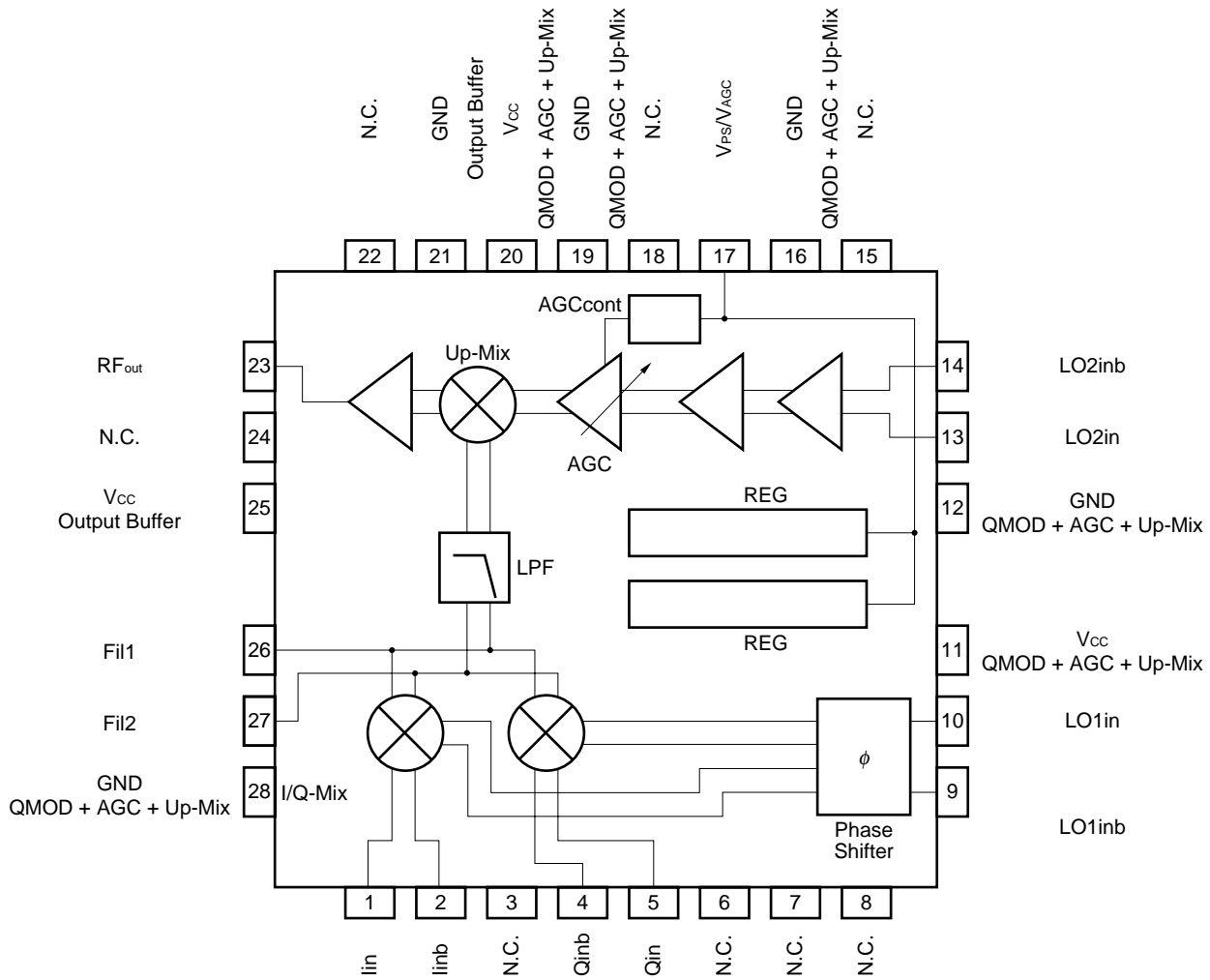

QUADRATURE MODULATOR SERIES

Part Number	Functions	I _{cc} (mA)	f _{LOin} (MHz)	f _{MODout} (MHz)	Up-Converter f _{RFout} (MHz)	Phase Shifter	Package	Application
μ PC8101GR	150 MHz Quad. Mod	15/@ 2.7 V	100 to 300	50 to 150	External	F/F	20-pin SSOP (225 mil)	CT-2, etc.
μ PC8104GR	RF Up-Converter + IF Quad. Mod	28/@ 3.0 V	100 to 400		900 to 1 900	Doubler + F/F	20-pin SSOP (225 mil)	Digital Comm.
μ PC8105GR	400 MHz Quad. Mod	16/@ 3.0 V	100 to 400		External		16-pin SSOP (225 mil)	
μ PC8110GR	1GHz Direct Quad. Mod	24/@ 3.0 V	800 to 1 000		Direct	Doubler + F/F	20-pin SSOP (225 mil)	PDC800 MHz, etc.
μ PC8125GR	RF Up-Converter + IF Quad. Mod + AGC	36/@ 3.0 V	220 to 270		1 800 to 2 000		PHS	
μ PC8126GR	900 MHz Direct Quad. Mod with Offset-Mixer	35/@ 3.0 V	915 to 960	915 to 960	(LO pre-mixer)		PDC800 MHz	
μ PC8126K			889 to 960				28-pin QFN	
μ PC8129GR	$\times 2$ LO IF Quad. Mod + RF Up-Converter	28/@ 3.0 V	200 to 800	100 to 400	800 to 1 900	F/F	20-pin SSOP (225 mil)	GSM, DCS1800, etc.
μ PC8139GR-7JH	Transceiver IC (1.9 GHz Indirect Quad. Mod + RX-IF + IF VCO)	TX: 32.5 RX: 4.8 /@ 3.0 V	220 to 270		1 800 to 2 000	CR	30-pin TSSOP (225 mil)	PHS
μ PC8158K	RF Up-Converter + IF Quad. Mod + AGC	28/@ 3.0 V	100 to 300		800 to 1 500		28-pin QFN	PDC800 M/ 1.5 G

For outline of the quadrature modulator series, please refer to the application note 'Usage of μ PC8101, 8104, 8105, 8125, 8129' (Document No. P13251E) and so on.

SYSTEM APPLICATION EXAMPLE

[PDC800 MHz/1.5 GHz]

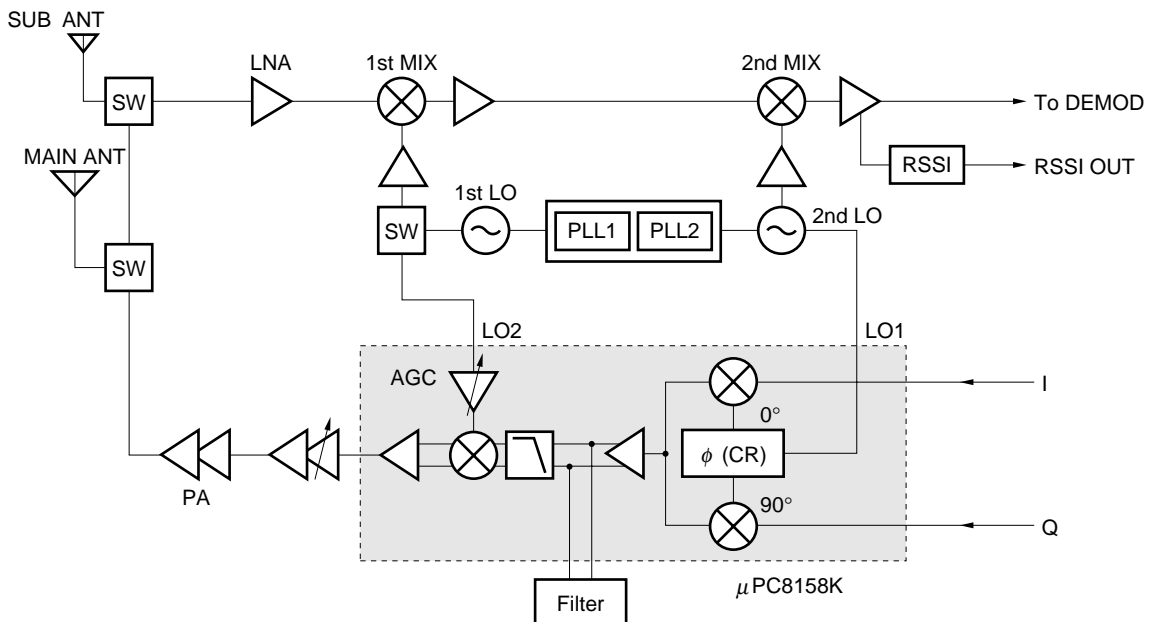

ABSOLUTE MAXIMUM RATINGS

Parameter	Symbol	Conditions	Rating	Unit
Supply Voltage	V _{CC}	Pin11, 20 and 25, T _A = +25°C	5.0	V
Power Save and AGC Control Pin Applied Voltage	V _{PS} /V _{AGC}	Pin17, T _A = +25°C	5.0	V
Power Dissipation	P _D	T _A = +85°C ^{Note}	430	mW
Operating Ambient Temperature	T _A		-40 to +85	°C
Storage Temperature	T _{stg}		-55 to +150	°C

Note Mounted on double sided copper clad 50 × 50 × 1.6 mm epoxy glass PWB.

RECOMMENDED OPERATING CONDITIONS

Parameter	Symbol	Test Conditions	MIN.	TYP.	MAX.	Unit
Supply Voltage	V _{CC}	Pin11, 20 and 25	2.7	3.0	4.0	V
Power Save Voltage	V _{PS}	Pin17	0	–	0.3	V
AGC Control Voltage	V _{AGCPS}	Pin17	1.0	–	2.5	V
Operating Ambient Temperature	T _A		-30	+25	+80	°C
Up-converter RF Output Frequency	f _{RFout}		800	–	1500	MHz
LO2 Input Frequency	f _{LO2in}	P _{LO2in} = -15 dBm	600	–	1750	MHz
I/Q Input Frequency	f _{I/Qin}	V _{I/Qin} = 500 mV _{P-P} MAX. (Differential input)	DC	–	10	MHz
LO1 Input Level	P _{LO1in}		-18	-15	-12	dBm
LO2 Input Level	P _{LO2in}		-18	-15	-12	dBm
I/Q Input Amplitude	V _{I/Qin}	I, Ib, Q, Qb each	–	420	500	mV _{P-P}
Up-converter Input Frequency	f _{UPCONin}		100	–	300	MHz
Modulator Output Frequency	f _{MODout}					
LO1 Input Frequency	f _{LO1in}	P _{LO1in} = -15 dBm				

ELECTRICAL CHARACTERISTICS

Conditions (Unless otherwise specified):

$T_A = +25\text{ }^\circ\text{C}$, $V_{CC1} = V_{CC2} = V_{CC3} = 3.0\text{ V}$, $V_{PS}/V_{AGC} = 2.5\text{ V}$,
 $I/Q\text{ (DC)} = I_b/Q_b\text{ (DC)} = V_{CC}/2 = 1.5\text{ V}$, $V_{I/bin} = V_{Q/Qbin} = 500\text{ mV}_{P-P}$ (each), $f_{I/Qin} = 2.625\text{ kHz}$,
 $\pi/4\text{DQPSK}$ wave input, transmission rate 42 kbps, filter roll-off $\alpha = 0.5$,
 Modulation Pattern: <0000>
 $f_{LO1in} = 178.05\text{ MHz}$, $P_{LO1in} = -15\text{ dBm}$
 $f_{LO2in} = 1619.05\text{ MHz}$, $P_{LO2in} = -15\text{ dBm}$
 $f_{RFout} = 1441\text{ MHz} - f_{I/Qin}$

Parameter	Symbol	Test Conditions	MIN.	TYP.	MAX.	Unit
UP-CONVERTER + QUADRATURE MODULATOR TOTAL						
Total Circuit Current	$I_{CC(TOTAL)}$	No input signal	23.7	28	37.6	mA
Total Circuit Current at Power Save Mode	$I_{CC(PS)TOTAL}$	$V_{PS} \leq 0.5\text{ V}$ (Low), No input signal	–	0.3	10	μA
Total Output Power 1	P_{RFout1}	$V_{AGC} = 2.5\text{ V}$	–15	–11.5	–8	dBm
Total Output Power 2	P_{RFout2}	$V_{AGC} = 1.0\text{ V}$	–56.5	–52	–46.5	dBm
LO Carrier Leak	LOL	$f_{LOL} = f_{LO1} + f_{LO2}$	–	–40	–30	dBc
Image Rejection (Side Band Leak)	ImR		–	–40	–30	dBc
I/Q 3rd order distortion	$IM_3(I/Q)$		–	–50	–30	dBc
AGC Gain Control Range	GCR	$V_{AGC} = 2\text{ V} \rightarrow 1\text{ V}$	35	40	–	dB
Error Vector Magnitude	EVM	MOD Pattern: PN9	–	1.2	3.0	%rms
Adjacent channel interference	P_{adj}	$\Delta f = \pm 50\text{ kHz}$, MOD Pattern: PN9	–	–65	–60	dBc
Spurious suppression	$P_{out(8fLO1)}$	$f_{LO1} \times 8$, $f_{LO1} \times 8$ (image) ^{Note}	–	–70	–65	dBc
Power Save Rise Time	$T_{PS(Rise)}$	$V_{PS(Low)} \rightarrow V_{PS(High)}$	–	2	5	μs
Power Save Fall Time	$T_{PS(Fall)}$	$V_{PS(High)} \rightarrow V_{PS(Low)}$	–	2	5	μs
I/Q input impedance	$Z_{I/Q}$	Between pin I/Ib, Q/Qb	80	200	–	kΩ
I/Q input bias current	$I_{I/Q}$	Between pin I/Ib, Q/Qb	–	5	13	μA
LO1 input VSWR	Z_{LO1}	$f_{LO1} = 100\text{ M to }300\text{ MHz}$	–	1.5:1	–	–







Note Without external LC between Fil1 and Fil2 pin on this frequency conditions.
 Spectrum analyzer conditions: VBW = 300 Hz, RBW = 300 Hz.

Remark Electrical characteristics in this document is described for 1.5 GHz system.

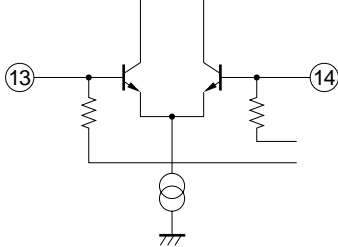
PIN EXPLANATIONS

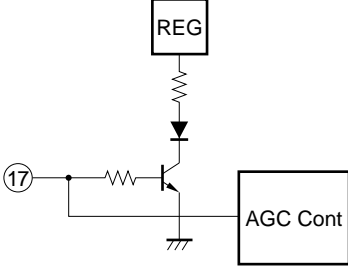
Pin No.	Symbol	Supply Voltage (V)	Pin Voltage (V) <small>Note</small>	Function and Application	Internal Equivalent Circuit
1	lin	V _{cc} /2	–	Input for I signal. This input impedance is 200 kΩ. In the case of that I/Q input signals are single ended, amplitude of the signal is 500 m V _{P-P} max.	
2	linb	V _{cc} /2	–	Input for I signal. This input impedance is 200 kΩ. In the case of that I/Q input signals are single ended, V _{cc} /2 biased DC signal should be input. In the case of the I/Q input signals are differential, amplitude of the signal is 500 m V _{P-P} max.	
3	N.C.	–	–	This pin is not connected to internal circuit. This pin should be opened or grounded.	_____
4	Qinb	V _{cc} /2	–	Input for Q signal. This input impedance is 200 kΩ. In the case of that I/Q input signals are single ended, amplitude of the signal is 500 m V _{P-P} max.	
5	Qin	V _{cc} /2	–	Input for I signal. This input impedance is 200 kΩ. In the case of that I/Q input signals are single ended, V _{cc} /2 biased DC signal should be input. In case of the I/Q input signals are differential, amplitude of the signal is 500 m V _{P-P} max.	
6	N.C.	–	–	These pins are not connected to internal circuit. These pins should be opened or grounded.	_____
7	N.C.				
8	N.C.				
9	LO1inb	–	2.98	Bypass pin of modulator's local input. This pin should be decoupled with 330 pF capacitor.	
10	LO1in	–	2.98	Local signal input for modulator. This pin must be coupled with DC cut capacitor 330 pF and should be terminated with 51 Ω resistor.	
11	V _{cc}	2.7 to 4.0	–	Supply voltage pin for modulator, up-converter and AGC circuits.	_____

Note Pin Voltages are measured on V_{cc} = 3.0 V.

Pin No.	Symbol	Supply Voltage (V)	Pin Voltage (V) ^{Note}	Function and Application	Internal Equivalent Circuit						
12	GND	0	–	Ground pin for modulator, up-converter and AGC circuits. This pin should be grounded with minimum inductance. Form the ground pattern as widely as possible to minimize ground impedance.							
13	LO2in	–	1.8	Local signal input for modulator. This pin must be coupled with DC cut capacitor 33 pF and should be terminated with 51 Ω resistor.							
14	LO2inb	–	1.8	Bypass pin of up-converter's local signal input. This pin should be decoupled with 33 pF capacitor.							
15	N.C.	–	–	This pin is not connected to internal circuit. This pin should be opened or grounded.							
16	GND	0	–	Ground pin for modulator, up-converter and AGC circuits. This pin should be grounded with minimum inductance.							
17	V _{PS} /V _{AGC}	V _{PS} /V _{AGC}	–	Power save control pin for modulator, up-converter and AGC circuits. This pin also assigned as gain control pin for AGC circuits. Operation status with applied voltages are as follows. <table border="1" data-bbox="639 1182 972 1314"> <thead> <tr> <th>V_{PS}/V_{AGC} (V)</th> <th>STATE</th> </tr> </thead> <tbody> <tr> <td>0 to 0.4</td> <td>OFF (Sleep Mode)</td> </tr> <tr> <td>1 to 2.5</td> <td>On (AGC Mode)</td> </tr> </tbody> </table>	V _{PS} /V _{AGC} (V)	STATE	0 to 0.4	OFF (Sleep Mode)	1 to 2.5	On (AGC Mode)	
V _{PS} /V _{AGC} (V)	STATE										
0 to 0.4	OFF (Sleep Mode)										
1 to 2.5	On (AGC Mode)										
18	N.C.	–	–	This pin is not connected to internal circuit. This pin should be opened or grounded.							
19	GND	0	–	Ground pin for modulator, up-converter and AGC circuits. This pin should be grounded with minimum inductance.							
20	V _{CC}	2.7 to 4.0	–	Supply voltage pin for modulator, up-converter and AGC circuits.							
21	GND	0	–	Ground pin for RF output buffer. This pin should be grounded with minimum inductance.							

Note Pin Voltages are measured on V_{CC} = 3.0 V.

Pin No.	Symbol	Supply Voltage (V)	Pin Voltage (V) <small>Note</small>	Function and Application	Internal Equivalent Circuit
22	N.C.	–	–	This pin is not connected to internal circuit. This pin should be opened or grounded.	_____
23	RFout	–	1.75	RF output pin. This pin is emitter follower which is low impedance output port. This pin can be easily matched to 50 Ω impedance using external coupling and decoupling capacitors.	<p>The diagram shows an emitter follower circuit. The base of a transistor is connected to a biasing network consisting of a resistor to Vcc and a capacitor to ground. The emitter is connected to ground through a resistor. The collector is connected to Vcc through a resistor. The output of the emitter is connected to pin 23. An external matching network, enclosed in a dashed box labeled 'External', is connected between pin 23 and ground, consisting of a series capacitor and a shunt capacitor to ground.</p>
24	N.C.	–	–	These pins are not connected to internal circuit. These pins should be opened or grounded.	_____
25	Vcc	2.7 to 4.0	–	Supply voltage pin for RF output buffer.	_____
26	Fil1	–	2.76	External inductor and capacitor can suppress harmonics spurious of LO1 frequency. LC value should be determined according to LO1 input frequency and suppression level.	<p>The diagram shows an LC filter network. It consists of a series inductor connected between pins 26 and 27. This inductor is connected to a shunt capacitor to ground. The other end of the shunt capacitor is connected to a series resistor to ground. The circuit is enclosed in a dashed box labeled 'External'.</p>
27	Fil2	–	2.76		
28	GND	0	–	Ground pin for modulator, up-converter and AGC circuits. This pin should be grounded with minimum inductance. Form the ground pattern as widely as possible to minimize ground impedance.	_____

Note Pin Voltages are measured on Vcc = 3.0 V.

RECOMMENDED SOLDERING CONDITIONS

This product should be soldered under the following recommended conditions. For soldering methods and conditions other than those recommended below, contact your NEC sales representative.

μPC8158K

Soldering Method	Soldering Conditions	Recommended Condition Symbol
Infrared Reflow	Package peak temperature: 235°C or below Time: 30 seconds or less (at 210°C) Count: 2, Exposure limit ^{Note} : None	IR35-00-2
Partial Heating	Pin temperature: 300°C Time: 3 seconds or less (per side of device) Exposure limit ^{Note} : None	—

Note After opening the dry pack, keep it in a place below 25°C and 65% RH for the allowable storage period.

Caution Do not use different soldering methods together (except for partial heating).

For details of recommended soldering conditions for surface mounting, refer to information document SEMICONDUCTOR DEVICE MOUNTING TECHNOLOGY MANUAL (C10535E).

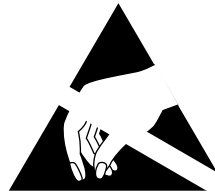

ATTENTION

OBSERVE PRECAUTIONS
FOR HANDLING
ELECTROSTATIC
SENSITIVE
DEVICES

NESAT (NEC Silicon Advanced Technology) is a trademark of NEC Corporation.

No part of this document may be copied or reproduced in any form or by any means without the prior written consent of NEC Corporation. NEC Corporation assumes no responsibility for any errors which may appear in this document.

NEC Corporation does not assume any liability for infringement of patents, copyrights or other intellectual property rights of third parties by or arising from use of a device described herein or any other liability arising from use of such device. No license, either express, implied or otherwise, is granted under any patents, copyrights or other intellectual property rights of NEC Corporation or others.

While NEC Corporation has been making continuous effort to enhance the reliability of its semiconductor devices, the possibility of defects cannot be eliminated entirely. To minimize risks of damage or injury to persons or property arising from a defect in an NEC semiconductor device, customers must incorporate sufficient safety measures in its design, such as redundancy, fire-containment, and anti-failure features.

NEC devices are classified into the following three quality grades:

"Standard", "Special", and "Specific". The Specific quality grade applies only to devices developed based on a customer designated "quality assurance program" for a specific application. The recommended applications of a device depend on its quality grade, as indicated below. Customers must check the quality grade of each device before using it in a particular application.

Standard: Computers, office equipment, communications equipment, test and measurement equipment, audio and visual equipment, home electronic appliances, machine tools, personal electronic equipment and industrial robots

Special: Transportation equipment (automobiles, trains, ships, etc.), traffic control systems, anti-disaster systems, anti-crime systems, safety equipment and medical equipment (not specifically designed for life support)

Specific: Aircrafts, aerospace equipment, submersible repeaters, nuclear reactor control systems, life support systems or medical equipment for life support, etc.

The quality grade of NEC devices is "Standard" unless otherwise specified in NEC's Data Sheets or Data Books. If customers intend to use NEC devices for applications other than those specified for Standard quality grade, they should contact an NEC sales representative in advance.

Anti-radioactive design is not implemented in this product.