

VERTICAL DRIVER FOR CCD SENSORS

The μ PD16520 is a vertical driver for CCD image sensors that has a level conversion circuit and a 3-level output function. Since it incorporates a CCD vertical register driver equivalent to the μ PD16510 (10 channels, consisting of six 3-level channels and four 2-level channels) and a VOD shutter driver (1 channel), it is ideal as a vertical driver for multiple-electrode high-pixel CCD transfer type area image sensors employed in digital still cameras.

The μ PD16520 uses a CMOS process to achieve optimum transmission delay characteristics for vertical driving of CCD image sensors, as well as output on-state resistance characteristics. The μ PD16520 also supports low-voltage logic (logic supply voltage: 2.0 to 5.5 V).

FEATURES

- CCD vertical register driver: 10 channels (3-level: 6 channels, 2-level: 4 channels)
- VOD shutter driver: 1 channel
- High withstand voltage: 33 V Max.
- Low-output on-state resistance: 30 Ω TYP.
- Low-voltage input supported (Logic supply voltage: 2.0 to 5.5 V)
- Latch-up free
- Same drive capacity as μ PD16510
- Small package: 38-pin plastic shrink SOP (300 mil)

APPLICATIONS

Digital still cameras, digital video cameras, etc.

ORDERING INFORMATION

Part Number	Package
μ PD16520GS-BGG	38-pin plastic shrink SOP (300 mil)

The information in this document is subject to change without notice. Before using this document, please confirm that this is the latest version.
Not all devices/types available in every country. Please check with local NEC representative for availability and additional information.

PIN CONFIGURATION (TOP VIEW)

- 38-pin plastic shrink SOP (300 mil)
μPD16520GS-BGG

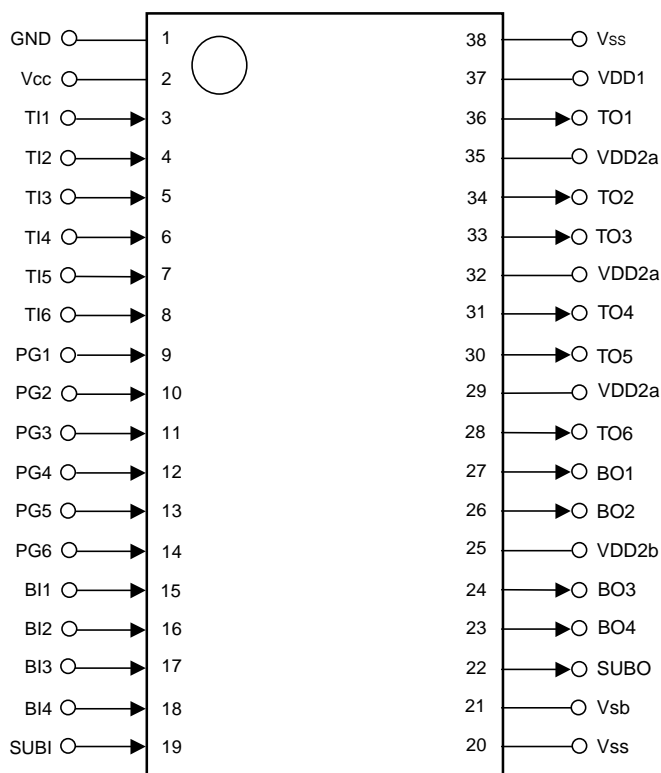

PIN NAMES

BI1 to BI4:	2 Level Driver Input	TO1 to TO6:	3 Level Pulse Output
BO1 to BO4:	2 Level Pulse Output	VDD1:	Power Supply (V _H)
GND:	Ground	VDD2a:	Power Supply (V _{Ma})
PG1 to PG6:	3 Level Driver Input	VDD2b:	Power Supply (V _{Mb})
SUBI:	VOD Shutter Drive Pulse Input	Vcc:	Power Supply (Logic)
SUBO:	VOD Shutter Drive Pulse Output	Vsb:	Power Supply (V _{HH})
TI1 to TI6:	3 Level Driver Input	Vss:	Power Supply (V _L)

BLOCK DIAGRAM

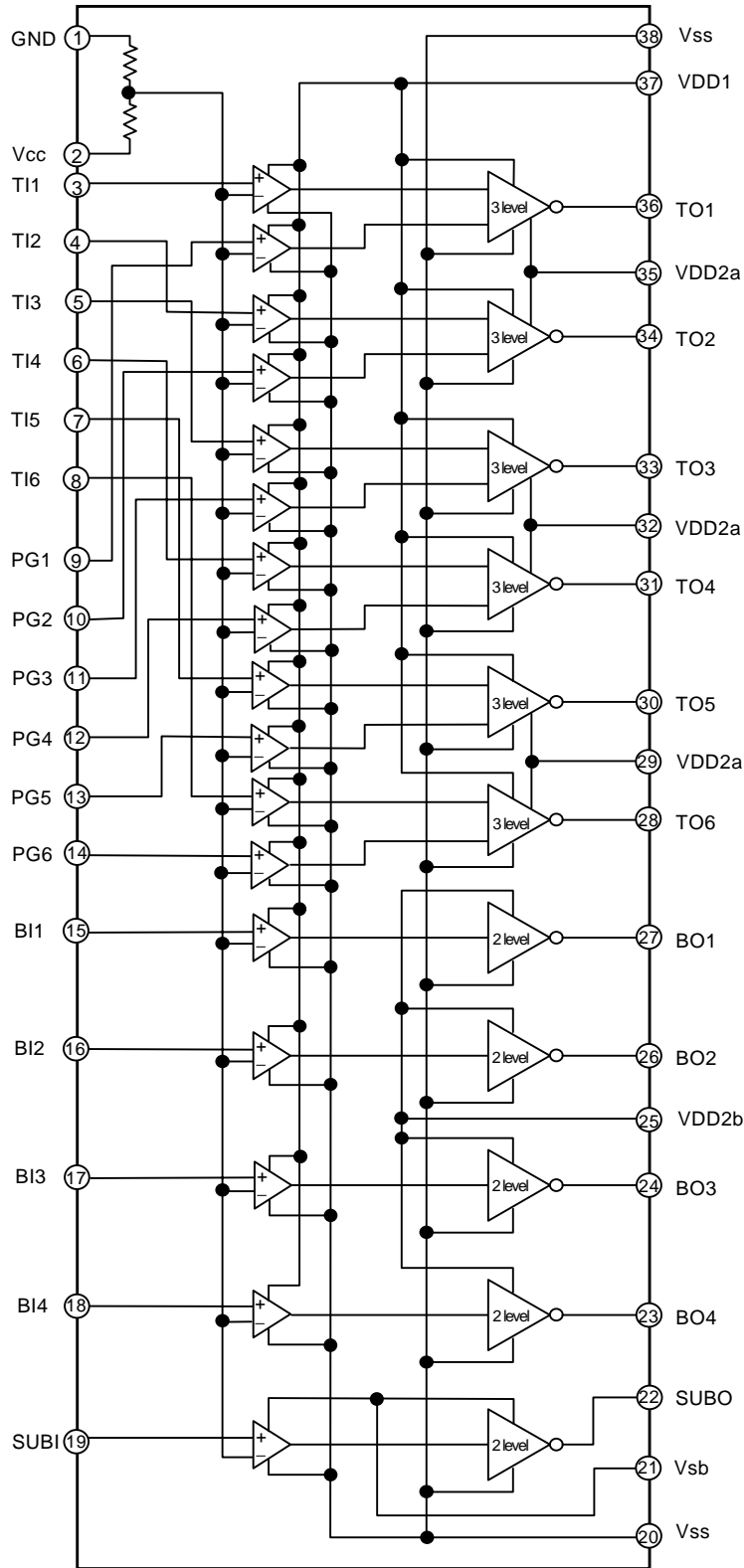

1. PIN FUNCTIONS

Pin No.	Pin Name	I/O	Function
1	GND	–	Ground
2	V _{CC}	–	Logic power supply
3	TI1	I	3-level driver input (for charge transfer) (See Function Tables.)
4	TI2	I	
5	TI3	I	
6	TI4	I	
7	TI5	I	
8	TI6	I	
9	PG1	I	3-level driver input (for charge read) (See Function Tables.)
10	PG2	I	
11	PG3	I	
12	PG4	I	
13	PG5	I	
14	PG6	I	
15	BI1	I	2-level driver input (for charge transfer) (See Function Tables.)
16	BI2	I	
17	BI3	I	
18	BI4	I	
19	SUBI	I	VOD shutter drive pulse input
20	V _{SS}	–	V _L power supply
21	V _{SB}	–	V _{HH} power supply (for SUB drive)
22	SUBO	O	VOD shutter drive pulse output
23	BO4	O	2-level pulse output
24	BO3	O	
25	VDD2b	–	V _{Mb} power supply (for 2-level driver)
26	BO2	O	2-level pulse output
27	BO1	O	
28	TO6	O	3-level pulse output
29	VDD2a	–	V _{Ma} power supply (for 3-level driver)
30	TO5	O	3-level pulse output
31	TO4	O	
32	VDD2a	–	V _{Ma} power supply (for 3-level driver)
33	TO3	O	3-level pulse output
34	TO2	O	
35	VDD2a	–	V _{Ma} power supply (for 3-level driver)
36	TO1	O	3-level pulse output
37	VDD1	–	V _H power supply
38	V _{SS}	–	V _L power supply

Function Tables

$V_L = V_{SS}$, $V_{Ma} = VDD2a$, $V_{Mb} = VDD2b$, $V_H = VDD1$, $V_{HH} = V_{sb}$

Pins TO1 to TO6

	Input												Output					
Pin Name	TI1	TI2	TI3	TI4	TI5	TI6	PG1	PG2	PG3	PG4	PG5	PG6	TO1	TO2	TO3	TO4	TO5	TO6
Pin No.	3	4	5	6	7	8	9	10	11	12	13	14	36	34	33	31	30	28
	L						L						V_H					
	L						H						V_{Ma}					
	H						L						V_L					
	H						H						V_L					

Pins BO1 to BO4

	Input				Output			
Pin Name	BI1	BI2	BI3	BI4	BO1	BO2	BO3	BO4
Pin No.	15	16	17	18	27	26	24	23
	L				V_{Mb}			
	H				V_L			

Pin SUBO

	Input	Output
Pin Name	SUBI	SUBO
Pin No.	19	22
	L	V_{HH}
	H	V_L

2. ELECTRICAL SPECIFICATIONS

Absolute Maximum Ratings (T_A = 25°C, GND = 0 V)

Parameter	Symbol	Conditions	Ratings	Unit
Supply voltage	V _{SS}		0.0 to -10	V
	V _{CC}		V _{SS} - 0.3 to V _{SS} + 20.0	V
	VDD1		V _{SS} - 0.3 to V _{SS} + 33.0	V
	VDD2		V _{SS} - 0.3 to V _{SS} + 33.0	V
	V _{sb}		V _{SS} - 0.3 to V _{SS} + 33.0	V
Input pin voltage	V _I		V _{SS} - 0.3 to V _{CC} + 0.3	V
Operating ambient temperature	T _A		-25 to +85	°C
Storage temperature	T _{stg}		-40 to +125	°C
Allowable dissipation	P _d		500	mW

Caution Product quality may suffer if the absolute maximum rating is exceeded even momentarily for any parameter. That is, the absolute maximum ratings are rated values at which the product is on the verge of suffering physical damage, and therefore the product must be used under conditions that ensure that the absolute maximum ratings are not exceeded.

Recommended Operating Range (T_A = 25°C, GND = 0 V)

Parameter	Symbol	Conditions	MIN.	TYP.	MAX.	Unit
Supply voltage	V _{CC}		2.0		5.5	V
	VDD1	Note	10.5	15.0	21.0	V
	VDD1-V _{SS}	Note	16.5		31.0	V
	VDD2a		-1.0		+4.0	V
	VDD2b		-1.0		+4.0	V
	V _{SS}		-10.0		-6.0	V
	V _{sb} -V _{SS}	Note			31.0	V
Input voltage, high	V _{IH}		0.8V _{CC}		V _{CC}	V
Input voltage, low	V _{IL}		0		0.3V _{CC}	V
Operating ambient temperature	T _A		-20		+70	°C

Note Set VDD1 and V_{SS} to values that satisfy VDD1-V_{SS} rating.

Electrical Specifications

(Unless otherwise specified, VDD1 = +15 V, VDD2a = 0 V, VDD2b = +1.0 V, Vsb = +21.5 V, Vcc = +2.5 V, Vss = -7.0 V, TA = 25°C, GND = 0 V)

Parameter	Symbol	Conditions	MIN.	TYP.	MAX.	Unit
Output voltage, high	V _H	I _o = -20 μA	VDD1 - 0.1		VDD1	V
Output voltage, middle	V _{Ma}	I _o = -20 μA	VDD2a - 0.1		VDD2a	V
	V _{Mb}	I _o = 20 μA	VDD2b		VDD2b + 0.1	V
Output voltage, low	V _L	I _o = 20 μA	V _{ss}		V _{ss} + 0.1	V
Output voltage, sub-high	V _{subH}	I _o = -20 μA	Vsb - 0.1		Vsb	V
Output voltage, sub-low	V _{subL}	I _o = 20 μA	V _{ss}		V _{ss} + 0.1	V
Output on-state resistance	R _L	I _o = 10 mA		20	30	Ω
	R _M	I _o = ±10 mA		30	45	Ω
	R _H	I _o = -10 mA		30	40	Ω
	R _{sub}			30	40	Ω
Transmission delay time 1	TD1	No load			200	ns
Transmission delay time 2	TD2	See Figure 2-2 Timing Charts.			200	ns
Transmission delay time 3	TD3				200	ns
Rise/fall time 1	TP1		See Figure 2-1 Output Load Equivalence Circuit.			500
Rise/fall time 2	TP2				500	ns
Rise/fall time 3	TP3	See Figure 2-2 Timing Charts.			200	ns

Figure 2-1. Output Load Equivalence Circuit

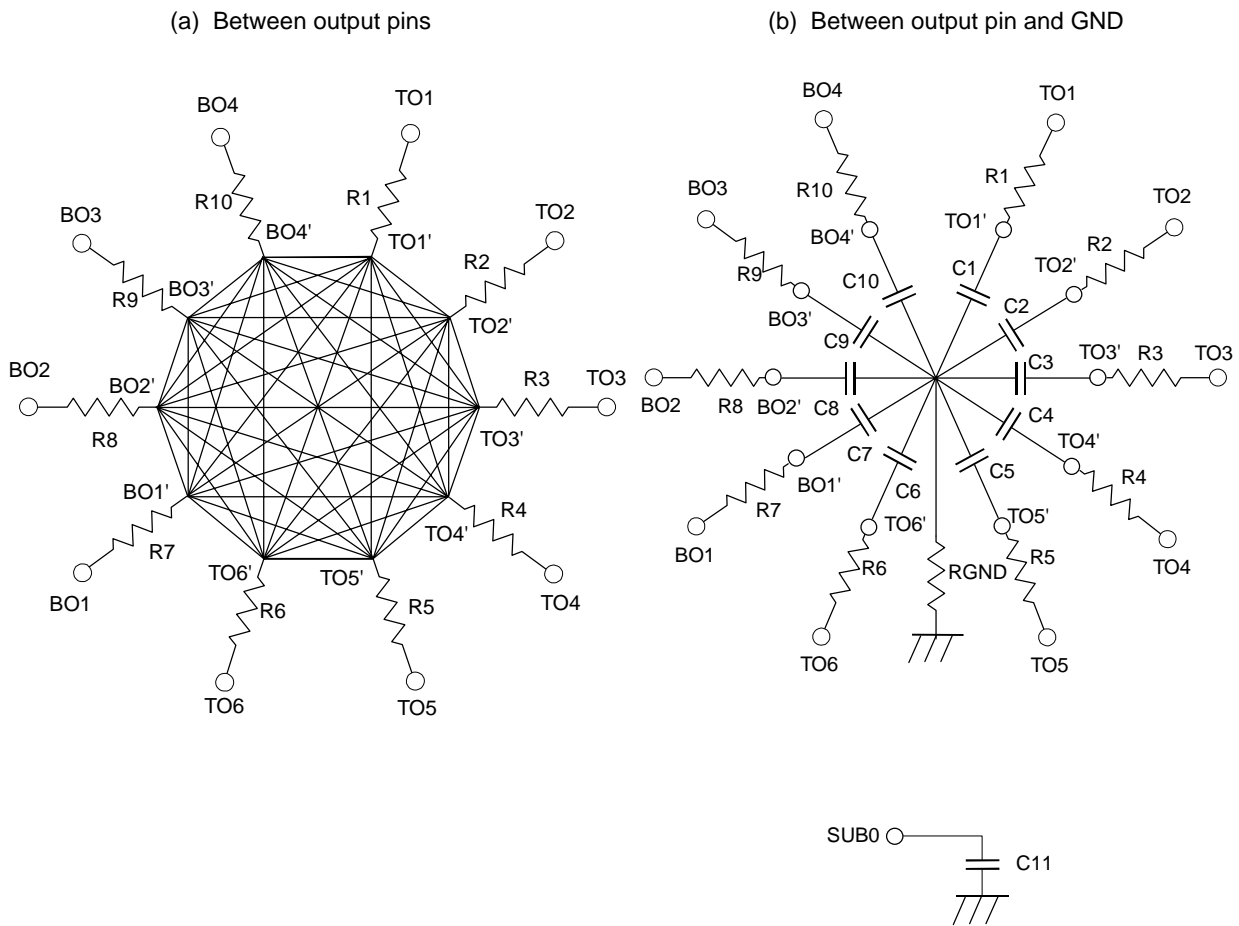

Output Load Capacitance Symbol

	TO1'	TO2'	TO3'	TO4'	TO5'	TO6'	BO1'	BO2'	BO3'	BO4'	GND
TO1'	–	C_33	C_33	C_33	C_33	C_33	C_32	C_23	C_32	C_23	C1
TO2'	C_33	–	C_33	C_33	C_33	C_33	C_23	C_32	C_23	C_32	C2
TO3'	C_33	C_33	–	C_33	C_33	C_33	C_32	C_23	C_32	C_23	C3
TO4'	C_33	C_33	C_33	–	C_33	C_33	C_23	C_32	C_23	C_32	C4
TO5'	C_33	C_33	C_33	C_33	–	C_33	C_32	C_23	C_32	C_23	C5
TO6'	C_33	C_33	C_33	C_33	C_33	–	C_23	C_32	C_23	C_32	C6
BO1'	C_32	C_23	C_32	C_23	C_32	C_23	–	C_22	C_22	C_22	C7
BO2'	C_23	C_32	C_23	C_32	C_23	C_32	C_22	–	C_22	C_22	C8
BO3'	C_32	C_23	C_32	C_23	C_32	C_23	C_22	C_22	–	C_22	C9
BO4'	C_23	C_32	C_23	C_32	C_23	C_32	C_22	C_22	C_22	–	C10
SUB0	–	–	–	–	–	–	–	–	–	–	C11

Output Load Equivalence Circuit Constants

Parameter	Symbol	Constant
Vertical register serial resistor	R1 to R10	0 Ω
Vertical register ground resistor	RGND	0 Ω
Capacitance 1 between vertical register clocks (3 level-3 level)	C_33	0 pF
Capacitance 2 between vertical register clocks (2 level-2 level)	C_22	0 pF
Capacitance 3 between vertical register clocks (3 level-2 level)	C_32	1000 pF
Capacitance 4 between vertical register clocks (2 level-3 level)	C_23	500 pF
Vertical register ground capacitance 1 (3 level)	C1 to C6	3000 pF
Vertical register ground capacitance 2 (2 level)	C7 to C10	1500 pF
Substrate ground capacitance	C11	1600 pF

Figure 2-2. Timing Charts

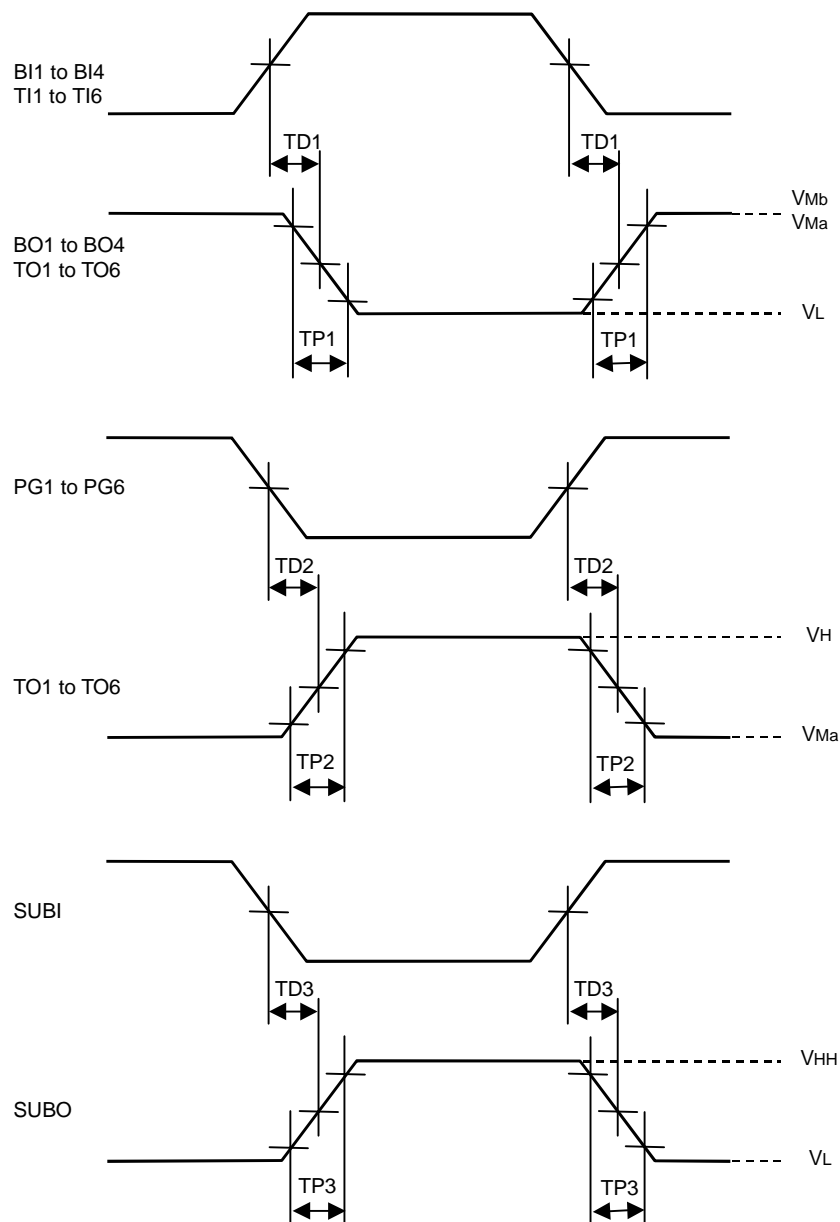

3. CAUTIONS

3.1 Power ON/OFF Sequence

In the μPD16520, a PN junction (diode) exists between VDD2 → VDD1, input pin (TI1 to TI6, PG1 to PG6, BI1 to BI4, SUBI) → Vcc, so that in the case of voltage conditions: VDD2 > VDD1, input pin voltage (TI1 to TI6, PG1 to PG6, BI1 to BI4, SUBI) > Vcc, an abnormal current flows. Therefore, when turning the power ON/OFF, make sure that the following voltage conditions are satisfied: VDD2 ≤ VDD1, input pin voltage (TI1 to TI6, PG1 to PG6, BI1 to BI4, SUBI) ≤ Vcc. Also, to minimize the negative potential applied to the SUB pin of the CCD image sensor, following the power ON/OFF sequence described below.

(1) Power ON

<1> Powering ON Vcc

Make sure that input pin voltage (TI1 to TI6, PG1 to PG6, BI1 to BI4, SUBI) ≤ Vcc. Also, when Vsb = 2 V, make sure that Vcc reaches the rated voltage.

<2> Powering ON Vsb, VDD1, VDD2a, VDD2b, Vss

At this time, make SUBI high level (0.8Vcc or higher).

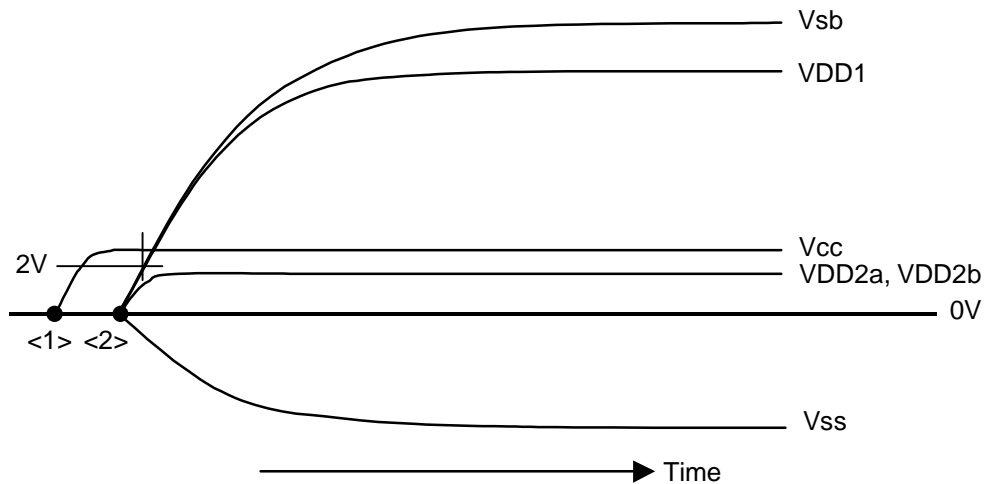

(2) Power OFF

<1> Powering OFF Vsb, VDD1, VDD2a, VDD2b, Vss

Until Vcc power OFF, keep SUBI high level (0.8Vcc or higher).

<2> Powering OFF Vcc

Power OFF Vcc when Vsb becomes 2 V or lower. At this time, make sure that the input pin voltage (TI1 to TI6, PG1 to PG6, BI1 to BI4, SUBI) ≤ Vcc.

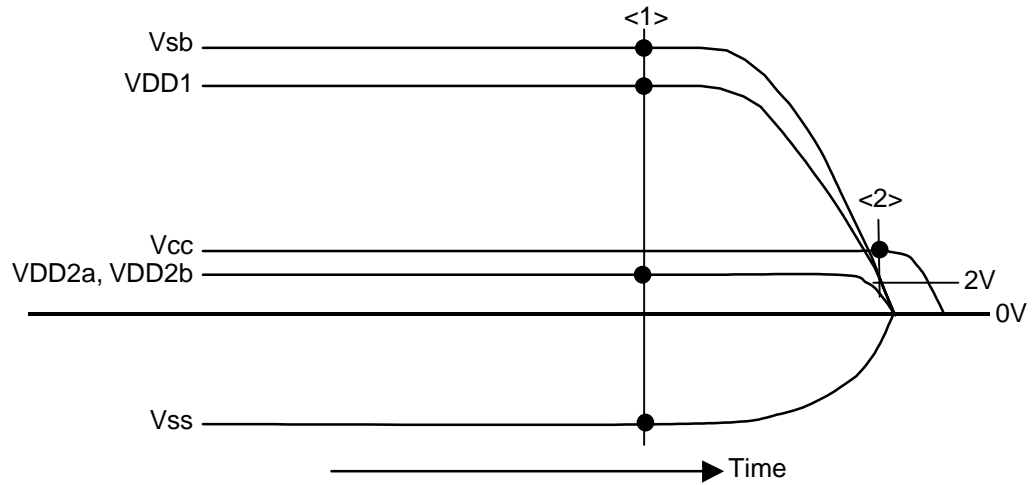

3.2. Recommended Connection of Unused Pins

Handle input pins and output pins that are not used as follows.

Input pin: High level (connect to Vcc)

Output pin: Leave open

4. APPLICATION CIRCUIT EXAMPLE

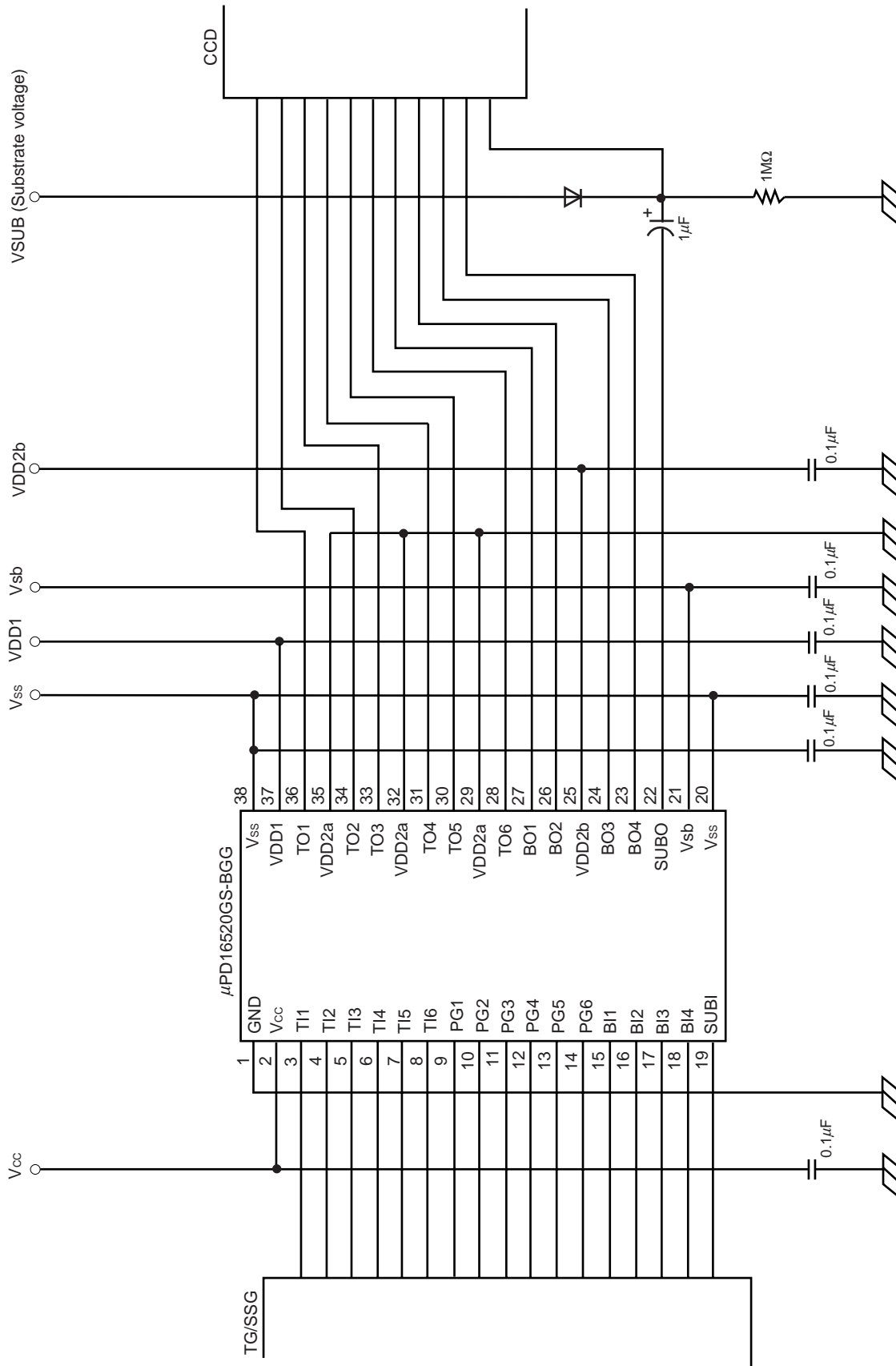

5. PACKAGE DRAWING

38-PIN PLASTIC SSOP (300 mil)

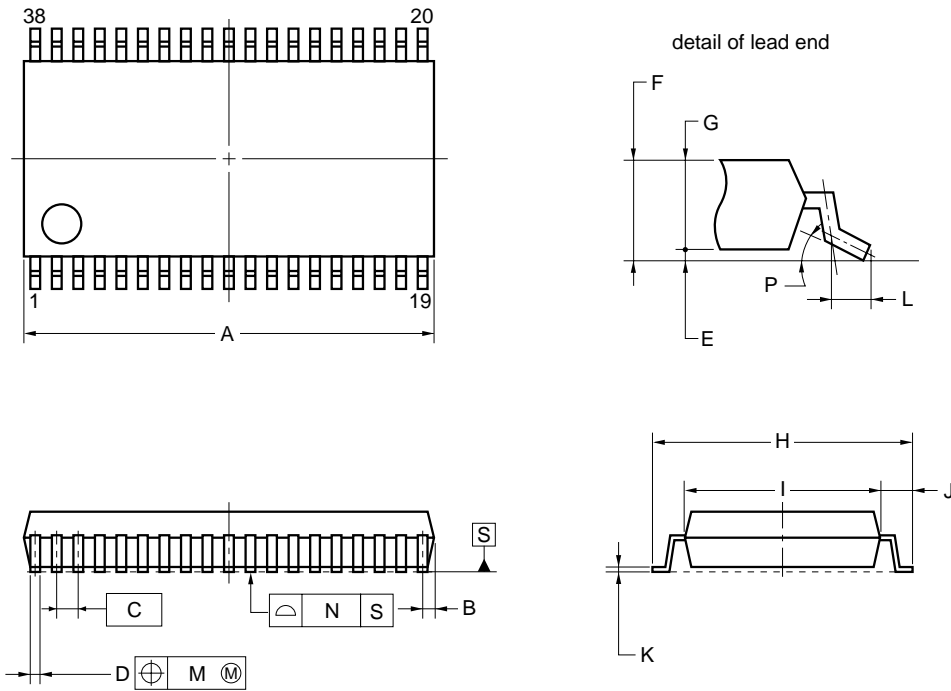

NOTE

Each lead centerline is located within 0.10 mm of its true position (T.P.) at maximum material condition.

ITEM	MILLIMETERS
A	12.7±0.3
B	0.65 MAX.
C	0.65 (T.P.)
D	0.37 ^{+0.05} _{-0.1}
E	0.125±0.075
F	1.675±0.125
G	1.55
H	7.7±0.2
I	5.6±0.2
J	1.05±0.2
K	0.2 ^{+0.1} _{-0.05}
L	0.6±0.2
M	0.10
N	0.10
P	3° ^{+7°} _{-3°}

P38GS-65-BGG

6. RECOMMENDED SOLDERING CONDITIONS

The μPD16520 should be soldered and mounted under the following recommended conditions.

For the details of the recommended soldering conditions, refer to the document **Semiconductor Device Mounting Manual (C10535E)**.

For soldering methods and conditions other than those recommended below, contact your NEC sales representative.

Table 6-1. Surface Mounting Type Soldering Conditions

- μPD16520GS-BGG: 38-pin plastic shrink SOP (300 mil)

Soldering Method	Soldering Conditions	Recommended Condition Symbol
Infrared reflow	Package peak temperature: 235°C, Time: 30 sec. Max. (at 210°C or higher), Count: Three times or less	IR35-00-3
VPS	Package peak temperature: 215°C, Time: 40 sec. Max. (at 200°C or higher), Count: Three times or less	VP15-00-3
Wave soldering	Solder bath temperature: 260°C, Time: 10 sec. Max., Count: Once, Preheating temperature: 120°C Max. (package surface temperature)	WS60-00-1
Partial heating	Pin temperature: 300°C Max., Time: 3 sec. Max. (per pin row)	–

Caution Do not use different soldering methods together (except for partial heating).

NOTES FOR CMOS DEVICES**① PRECAUTION AGAINST ESD FOR SEMICONDUCTORS**

Note:

Strong electric field, when exposed to a MOS device, can cause destruction of the gate oxide and ultimately degrade the device operation. Steps must be taken to stop generation of static electricity as much as possible, and quickly dissipate it once, when it has occurred. Environmental control must be adequate. When it is dry, humidifier should be used. It is recommended to avoid using insulators that easily build static electricity. Semiconductor devices must be stored and transported in an anti-static container, static shielding bag or conductive material. All test and measurement tools including work bench and floor should be grounded. The operator should be grounded using wrist strap. Semiconductor devices must not be touched with bare hands. Similar precautions need to be taken for PW boards with semiconductor devices on it.

② HANDLING OF UNUSED INPUT PINS FOR CMOS

Note:

No connection for CMOS device inputs can be cause of malfunction. If no connection is provided to the input pins, it is possible that an internal input level may be generated due to noise, etc., hence causing malfunction. CMOS devices behave differently than Bipolar or NMOS devices. Input levels of CMOS devices must be fixed high or low by using a pull-up or pull-down circuitry. Each unused pin should be connected to V_{DD} or GND with a resistor, if it is considered to have a possibility of being an output pin. All handling related to the unused pins must be judged device by device and related specifications governing the devices.

③ STATUS BEFORE INITIALIZATION OF MOS DEVICES

Note:

Power-on does not necessarily define initial status of MOS device. Production process of MOS does not define the initial operation status of the device. Immediately after the power source is turned ON, the devices with reset function have not yet been initialized. Hence, power-on does not guarantee out-pin levels, I/O settings or contents of registers. Device is not initialized until the reset signal is received. Reset operation must be executed immediately after power-on for devices having reset function.

- **The information in this document is subject to change without notice. Before using this document, please confirm that this is the latest version.**
 - No part of this document may be copied or reproduced in any form or by any means without the prior written consent of NEC Corporation. NEC Corporation assumes no responsibility for any errors which may appear in this document.
 - NEC Corporation does not assume any liability for infringement of patents, copyrights or other intellectual property rights of third parties by or arising from use of a device described herein or any other liability arising from use of such device. No license, either express, implied or otherwise, is granted under any patents, copyrights or other intellectual property rights of NEC Corporation or others.
 - Descriptions of circuits, software, and other related information in this document are provided for illustrative purposes in semiconductor product operation and application examples. The incorporation of these circuits, software, and information in the design of the customer's equipment shall be done under the full responsibility of the customer. NEC Corporation assumes no responsibility for any losses incurred by the customer or third parties arising from the use of these circuits, software, and information.
 - While NEC Corporation has been making continuous effort to enhance the reliability of its semiconductor devices, the possibility of defects cannot be eliminated entirely. To minimize risks of damage or injury to persons or property arising from a defect in an NEC semiconductor device, customers must incorporate sufficient safety measures in its design, such as redundancy, fire-containment, and anti-failure features.
 - NEC devices are classified into the following three quality grades:
"Standard", "Special", and "Specific". The Specific quality grade applies only to devices developed based on a customer designated "quality assurance program" for a specific application. The recommended applications of a device depend on its quality grade, as indicated below. Customers must check the quality grade of each device before using it in a particular application.
 - Standard: Computers, office equipment, communications equipment, test and measurement equipment, audio and visual equipment, home electronic appliances, machine tools, personal electronic equipment and industrial robots
 - Special: Transportation equipment (automobiles, trains, ships, etc.), traffic control systems, anti-disaster systems, anti-crime systems, safety equipment and medical equipment (not specifically designed for life support)
 - Specific: Aircraft, aerospace equipment, submersible repeaters, nuclear reactor control systems, life support systems or medical equipment for life support, etc.
- The quality grade of NEC devices is "Standard" unless otherwise specified in NEC's Data Sheets or Data Books. If customers intend to use NEC devices for applications other than those specified for Standard quality grade, they should contact an NEC sales representative in advance.