

Description

The μPD42273 is a dual-port graphics buffer equipped with a 256K x 4-bit random access port and a 512 x 4-bit serial read port. The serial read port is connected to an internal 2048-bit data register through a 512 x 4-bit serial read output circuit. The random access port is used by the host CPU to read or write data addressed in any desired order. A write-per-bit capability allows each of the four data bits to be individually selected or masked for a write cycle.

The μPD42273 features fully asynchronous dual access, except when transferring stored graphics data from a selected row of the storage array to the data register. During a data transfer, the random access port requires a special timing cycle using a transfer clock; the serial read port continues to operate normally. Following the clock transition of a data transfer, serial output data changes from an old line to a new line and the starting location on the new line is addressable in the data transfer cycle.

An advanced CMOS silicon-gate process using polyicide technology and trench capacitors provides high storage cell density, high performance, and high reliability.

Refreshing is accomplished by means of $\overline{\text{RAS}}$ -only refresh cycles or by normal read or write cycles on the 512 address combinations of A_0 through A_8 during an 8-ms period. Automatic internal refreshing, by means of either hidden refreshing or the $\overline{\text{CAS}}$ before $\overline{\text{RAS}}$ timing and on-chip internal refresh circuitry, is also available. The transfer of a row of data from the storage array to the data register also refreshes that row automatically.

The μPD42273 is an alternative to the μPD42274 for applications that do not require the flash write function.

All inputs and outputs, including clocks, are TTL-compatible. All address and data-in signals are latched on-chip to simplify system design. Data-out is unlatched to allow greater system flexibility.

The μPD42273 is available in a 28-pin plastic ZIP or 28-pin plastic SOJ and is guaranteed for operation at 0 to +70°C.

Features

- Three functional blocks
 - 256K x 4-bit random access storage array
 - 2048-bit data register
 - 512 x 4-bit serial read output circuit
- Two data ports: random access and serial read
- Dual-port accessibility except during data transfer
- Addressable start of serial read operation
- Real-time data transfer
- Single +5-volt ±10% power supply
- On-chip substrate bias generator
- Random access port
 - Two main clocks: $\overline{\text{RAS}}$ and $\overline{\text{CAS}}$
 - Multiplexed address inputs
 - Direct connection of I/O and address lines allowed by $\overline{\text{OE}}$ to simplify system design
 - 512 refresh cycles every 8 ms
 - Read, early write, late write, read-write/read-modify-write, $\overline{\text{RAS}}$ -only refresh, and fast-page cycles
 - Automatic internal refreshing by means of the $\overline{\text{CAS}}$ before $\overline{\text{RAS}}$ on-chip address counter
 - $\overline{\text{CAS}}$ -controlled hidden refreshing
 - Write-per-bit option regarding four I/O bits
 - Write bit selection multiplexed on IO_0 - IO_3
- $\overline{\text{RAS}}$ -activated data transfer
 - Same cycle time as for random access
 - Row data transferred to data register as specified by row address inputs
 - Starting location of following serial read cycle specified by column address inputs
 - Transfer of 2048 bits of data on one row to the data register, and the starting location of the serial read circuit, activated by a low-to-high transition of $\overline{\text{DT}}$
 - Data transfer during real-time operation or standby of serial port
- Fast serial read operation by means of SC pins
- Serial data output on SO_0 - SO_3
- Direct connection of multiple serial outputs for extension of data length
- Fully TTL-compatible inputs, outputs, and clocks
- Three-state outputs for random and serial access
- CMOS silicon-gate process with trench capacitors

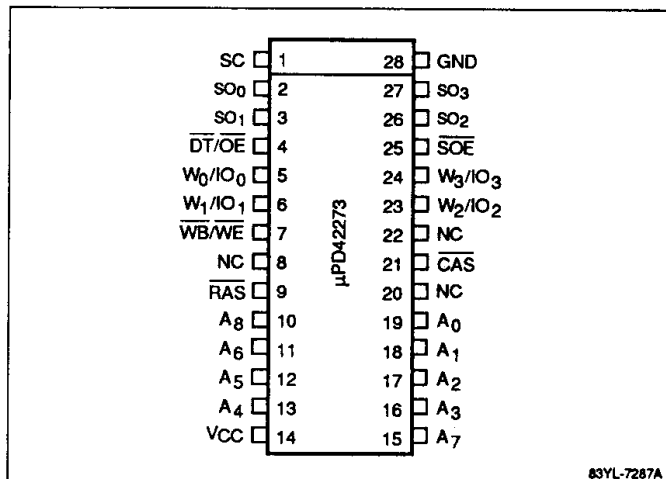
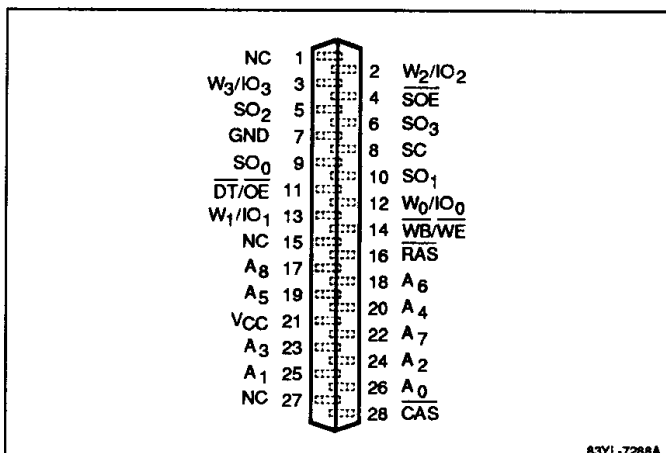
Pin Configurations**28-Pin Plastic SOJ****28-Pin Plastic ZIP****Pin Identification**

Symbol	Function
A ₀ - A ₈	Address inputs
W ₀ /IO ₀ - W ₃ /IO ₃	Write-per-bit selects/data inputs and outputs
RAS	Row address strobe
CAS	Column address strobe
WB/WE	Write-per-bit/write enable
DT/OE	Data transfer/output enable
SO ₀ - SO ₃	Serial read outputs
SC	Serial control
SOE	Serial output enable
GND	Ground
V _{CC}	+5-volt ±10% power supply
NC	No connection

Ordering Information

Part Number	Row Access Time (max)	Serial Access Time (max)	Package
μPD42273LE-10	100 ns	30 ns	28-pin plastic SOJ
LE-12	120 ns	40 ns	
μPD42273V-10	100 ns	30 ns	28-pin plastic ZIP
V-12	120 ns	40 ns	

Absolute Maximum Ratings

Voltage on any pin except V _{CC} relative to GND, V _{R1}	-1.0 to +7.0 V
Voltage on V _{CC} relative to GND, V _{R2}	-1.0 to +7.0 V
Operating temperature, T _{OPR}	0 to +70°C
Storage temperature, T _{STG}	-55 to +125°C
Short-circuit output current, I _{OS}	50 mA
Power dissipation, P _D	1.5 W

Exposure to Absolute Maximum Ratings for extended periods may affect device reliability; exceeding the ratings could cause permanent damage. The device should be operated within the limits specified under DC and AC Characteristics.

Recommended Operating Conditions

Parameter	Symbol	Min	Typ	Max	Unit
Supply voltage	V _{CC}	4.5	5.0	5.5	V
Input voltage, high	V _{IH}	2.4		5.5	V
Input voltage, low	V _{IL}	-1.0		0.8	V
Ambient temperature	T _A	0		70	°C

Capacitance

T_A = 0 to +70°C; V_{CC} = +5.0 V ±10%; f = 1 MHz; GND = 0 V

Parameter	Symbol	Limit (max)	Unit	Pins Under Test
Input capacitance	C _{I(A)}	5	pF	A ₀ through A ₈
	C _{I(DT/OE)}	8	pF	DT/OE
	C _{I(WB/WE)}	8	pF	WB/WE
	C _{I(RAS)}	8	pF	RAS
	C _{I(CAS)}	8	pF	CAS
	C _{I(SOE)}	8	pF	SOE
Input/output capacitance	C _{I(SC)}	8	pF	SC
	C _{IO(W/IO)}	7	pF	W ₀ /IO ₀ through W ₃ /IO ₃
Output capacitance	C _{O(SO)}	7	pF	SO ₀ through SO ₃

Block Diagram

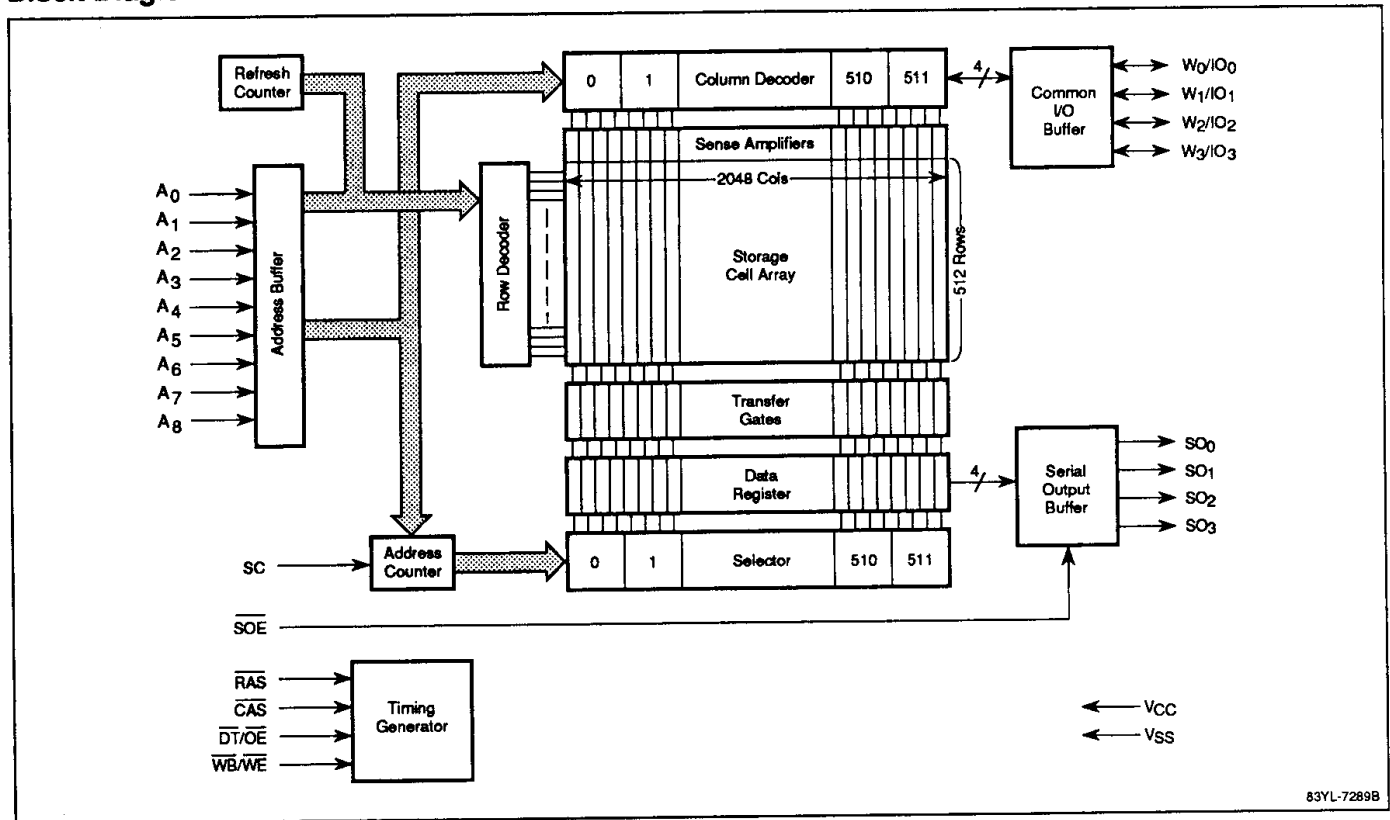

12c

Pin Functions

A₀-A₈ (Address Inputs). These pins are multiplexed as row and column address inputs. Each of four data bits in the random access port corresponds to 262,144 storage cells, which means that nine row addresses and nine column addresses are required to decode one cell location. Nine row addresses are first used to select one of the 512 possible rows for a read, write, data transfer, or refresh cycle. Nine column addresses are then used to select the one of 512 possible column decoders for a read or write cycle or the one of 512 possible starting locations for the next serial read cycle. (Column addresses are not required in RAS-only refresh or flash write cycles.)

W₀/IO₀-W₃/IO₃ (Write-Per-Bit Inputs/Common Data Inputs and Outputs). Each of the four data bits can be individually latched by these inputs at the falling edge of $\overline{\text{RAS}}$ in a write cycle, and then updated at the next falling edge of $\overline{\text{RAS}}$. In a read cycle, these pins serve as outputs for the selected storage cells. In a write cycle, data input on these pins is latched by the falling edge of $\overline{\text{CAS}}$ or $\overline{\text{WE}}$.

$\overline{\text{RAS}}$ (Row Address Strobe). This pin is functionally equivalent to a chip enable signal in that whenever it is

activated, the 2,048 storage cells of a selected row are sensed simultaneously and the sense amplifiers restore all data. The nine row address bits are latched by this signal and must be stable on or before its falling edge. $\overline{\text{CAS}}$, $\overline{\text{DT/OE}}$ and $\overline{\text{WB/WE}}$ are simultaneously latched to determine device operation.

$\overline{\text{CAS}}$ (Column Address Strobe). This pin serves as a chip selection signal to activate the column decoder and the input/output buffers. The nine column address bits are latched at the falling edge of $\overline{\text{CAS}}$.

$\overline{\text{WB/WE}}$ (Write-Per-Bit Control/Write Enable). At the falling edge of $\overline{\text{RAS}}$ the $\overline{\text{WB/WE}}$ input must be low and $\overline{\text{CAS}}$ and $\overline{\text{DT/OE}}$ high to enable the write-per-bit option. A high $\overline{\text{WB/WE}}$ can be used at the beginning of a standard write or read cycle.

$\overline{\text{DT/OE}}$ (Data Transfer/Output Enable). At the falling edge of $\overline{\text{RAS}}$, $\overline{\text{CAS}}$ high and $\overline{\text{FWE}}$ and $\overline{\text{DT/OE}}$ low initiate a data transfer, regardless of the level of $\overline{\text{WB/WE}}$. $\overline{\text{DT/OE}}$ high initiates conventional read or write cycles and controls the output buffer in the random access port.

SO₀-SO₃ (Serial Data Output). Four-bit data is read from these pins. Data remains valid until the next SC signal is activated.

12c-3

μPD42273

SC (Serial Control). Repeatedly activating this signal causes serial read cycles (starting from the location specified in the data transfer cycle) to be executed within the 2,048 bits in the data register. The rising edge of SC activates serial read operation, in which four of the 2,048 data bits are transferred to four serial data buses, respectively, and read out. Whenever SC is low, the serial port is in standby.

SOE (Serial Output Enable). This signal controls the serial data output buffer.

OPERATION

The μPD42273 consists of a random access port and a serial read port. The random access port executes standard read and write cycles as well as data transfer and flash write cycles, all of which are based on conventional $\overline{RAS}/\overline{CAS}$ timing.

In a data transfer, data in each storage cell on the selected row is transferred simultaneously through a transfer gate to its corresponding register location. The serial read port shows the contents of the data register in serial order. The random access and serial read ports can operate asynchronously, except when the transfer gate is turned on during the data transfer period.

Addressing

The storage array is arranged in a 512-row by 2048-column matrix, whereby each of 4 data bits in the random access port corresponds to 262,144 storage cells and 18 address bits are required to decode one cell location. Nine row address bits are set up on pins A_0 through A_8 and latched onto the chip by \overline{RAS} . Nine column address bits then are set up on pins A_9 through A_{17} and latched onto the chip by \overline{CAS} . All addresses must be stable, on or before the falling edges of \overline{RAS} and \overline{CAS} . Whenever \overline{RAS} is activated, 2048 cells on the selected row are sensed simultaneously and the sense amplifiers automatically restore the data. \overline{CAS} serves as a chip selection signal to activate the column decoder and the input and output buffers.

Through 1 of 512 column decoders, 4 storage cells on the row are connected to 4 data buses, respectively. In a data transfer cycle, 9 row address bits are used to select 1 of the 512 possible rows involved in the transfer of data to the data register. Nine column address bits are then used to select the 1 of 512 possible serial decoders that corresponds to the starting location of the next serial read cycle. In the serial read port, when SC is activated, 4 data bits in the 2048-bit data register are transferred to 4 serial data buses and read out. Activating SC repeatedly causes serial read cycles

(starting from the location specified in the data transfer cycle) to be executed within the 2048 bits in the data register.

Random Access Port

An operation in the random access port begins with a negative transition of \overline{RAS} . Both \overline{RAS} and \overline{CAS} have minimum pulse widths, as specified in the timing table, which must be maintained for proper device operation and data integrity. Once begun, a cycle must meet all specifications, including minimum cycle time. To reduce the number of pins, the following are multiplexed.

- $\overline{DT}/\overline{OE}$
- $\overline{WB}/\overline{WE}$
- W_i/IO_i ($i = 0, 1, 2, 3$)

\overline{OE} , \overline{WE} and IO_i represent standard operations, while \overline{DT} , \overline{WB} , and W_i are special inputs to be applied in the same way as row address inputs, with setup and hold times referenced to the negative transition of \overline{RAS} .

The level of \overline{DT} determines whether a cycle is a random access or data transfer operation. \overline{WB} affects only write cycles and determines whether or not the write-per-bit capability is used. W_i defines data bits to be written with the write-per-bit option. In the following discussions, these multiplexed pins are designated as $\overline{DT}/(\overline{OE})$, for example, depending on the function being described.

To use the μPD42273 for random access, $\overline{DT}/(\overline{OE})$ must be high as \overline{RAS} falls to disconnect the 2048-bit register from the corresponding 2048-digit lines of the storage array. Conversely, to execute a data transfer, $\overline{DT}/(\overline{OE})$ must be low as \overline{RAS} falls to open the 2048 transfer gates and transfer data from one of the rows to the register.

Truth Table for the Random Access Port

\overline{CAS}	$\overline{DT}/\overline{OE}$	$\overline{WB}/\overline{WE}$	Cycle
H	H	H	Read or write (Note 1)
H	H	L	Mask write (Note 2)
H	L	X	Read data transfer (Note 3)
L	X	X	\overline{CAS} before \overline{RAS} refresh (Note 4)

Notes:

- (1) Initiates a normal read or write cycle and disables the write-per-bit capability.
- (2) Enables individual bits to be selected or masked for a write cycle. Four-bit masked data is latched at the falling edge of \overline{RAS} and reset at the rising edge of \overline{RAS} .
- (3) Initiates a read data transfer cycle.
- (4) Initiates a \overline{CAS} before \overline{RAS} refresh cycle. As \overline{RAS} falls, $\overline{WB}/\overline{WE}$ and $\overline{DT}/\overline{OE}$ = don't care.
- (5) X = don't care.

Read Cycle. A read cycle is executed by activating \overline{RAS} , \overline{CAS} , and \overline{OE} and by maintaining $(\overline{WB}/\overline{WE})$ while \overline{CAS} is active. The (W_i/IO_i) pin ($i = 0, 1, 2, 3$) remains in high impedance until valid data appears at the output at access time. Device access time, t_{ACC} , will be the longest of the following four calculated intervals:

- t_{RAC}
- \overline{RAS} to $\pm CAS$ delay (t_{RCD}) + t_{CAC}
- \overline{RAS} to column address delay (t_{RAD}) + t_{AA}
- \overline{RAS} to \overline{OE} delay + t_{OEA}

Access times from \overline{RAS} (t_{RAC}), from \overline{CAS} (t_{CAC}), from the column addresses (t_{AA}), and from \overline{OE} (t_{OEA}) are device parameters. The \overline{RAS} -to- \overline{CAS} , \overline{RAS} -to-column address, and \overline{RAS} -to- \overline{OE} delays are system-dependent timing parameters. Output becomes valid after the access time has elapsed and it remains valid while both \overline{CAS} and \overline{OE} are low. Either \overline{CAS} or \overline{OE} high returns the output pins to high impedance.

Write Cycle. A write cycle is executed by bringing $(\overline{WB}/\overline{WE})$ low during the $\overline{RAS}/\overline{CAS}$ cycle. The falling edge of \overline{CAS} or $(\overline{WB}/\overline{WE})$ strobes the data on (W_i/IO_i) into the on-chip data latch. To make use of the write-per-bit option, $(\overline{WB}/\overline{WE})$ must be low as \overline{RAS} falls. In this case, write data bits can be specified by keeping W_i/IO_i high, with setup and hold times referenced to the negative transition of \overline{RAS} .

For those data bits of W_i/IO_i that are kept low as \overline{RAS} falls, write operation is inhibited on the chip. If $(\overline{WB}/\overline{WE})$ is high as \overline{RAS} falls, the write-per-bit option is not used and a write cycle is executed for all four data bits.

Early Write Cycle. An early write cycle is executed by bringing $(\overline{WB}/\overline{WE})$ low before \overline{CAS} falls. Data is strobed by \overline{CAS} , with setup and hold times referenced to this signal, and the output remains in high impedance for the entire cycle. As \overline{RAS} falls, $(\overline{DT})\overline{OE}$ must meet the setup and hold times of a high \overline{DT} , but otherwise $(\overline{DT})\overline{OE}$ does not affect anything while \overline{CAS} is active.

Read-Write/Read-Modify-Write Cycle. This cycle is executed by bringing $(\overline{WB}/\overline{WE})$ low with the \overline{RAS} and \overline{CAS} signals low. (W_i/IO_i) shows read data at access time. Afterward, in preparation for the upcoming write cycle, (W_i/IO_i) returns to high impedance when $(\overline{DT})\overline{OE}$ goes high. The data to be written is strobed by $(\overline{WB}/\overline{WE})$, with setup and hold times referenced to this signal.

Late Write Cycle. This cycle shows the timing flexibility of $(\overline{DT})\overline{OE}$, which can be activated just after $(\overline{WB}/\overline{WE})$ falls, even when $(\overline{WB}/\overline{WE})$ is brought low after \overline{CAS} .

Refresh Cycle. A cycle at each of the 512 row addresses (A_0 through A_8) will refresh all storage cells. Any read, write, refresh, or data transfer cycle executed in

the random access port refreshes the 2048 bits selected by the \overline{RAS} addresses or by the on-chip address counter.

\overline{RAS} -Only Refresh Cycle. A cycle having only \overline{RAS} active refreshes all cells in one row of the storage array. A high \overline{CAS} is maintained while \overline{RAS} is active to keep (W_i/IO_i) in high impedance. This method is preferred for refreshing, especially when the host system consists of multiple rows of random access devices. The data outputs may be OR-tied with no bus contention when \overline{RAS} -only refresh cycles are executed.

\overline{CAS} Before \overline{RAS} Refresh Cycle. This cycle executes internal refreshing using the on-chip circuitry. Whenever \overline{CAS} is low as \overline{RAS} falls, the row addresses specified by the internal counter are automatically refreshed and the circuit operation based on \overline{CAS} is maintained in a reset state. When internal refreshing is complete, the address counter automatically increments in preparation for the next \overline{CAS} before \overline{RAS} cycle.

Hidden Refresh Cycle. This cycle is executed after a read cycle, without disturbing the read data output. Once valid, the data output is controlled by \overline{CAS} and \overline{OE} . After the read cycle, \overline{CAS} is held low while \overline{RAS} goes high for precharge. A \overline{RAS} -only cycle is then executed (except that \overline{CAS} is held at a low level instead of a high level) and the data output remains valid. Since hidden refreshing is the same as \overline{CAS} before \overline{RAS} refreshing, the data output remains valid during either operation.

Fast-Page Cycle. This feature allows faster data access by keeping the same row address while successive column addresses are strobed onto the chip. Maintaining \overline{RAS} low while successive \overline{CAS} cycles are executed causes data to be transferred at a faster rate because row addresses are maintained internally and do not have to be reapplied. In fast-page operation, read, write and read-write/read-modify-write cycles may be executed. Additionally, the write-per-bit control specified in the entry write cycle is maintained throughout the next fast-page write cycle.

During a fast-page read cycle, (W_i/IO_i) remains in high impedance until valid data appears at the output pin at access time. Device access time in this cycle will be one of the following calculated intervals:

Fast-Page Access Time

Calculated Interval	Conditions
t_{ACP}	$t_{ASC} \geq t_{CP}$ and $t_{CP} \leq t_{CP}(\max)$
t_{AA}	$t_{ASC} \leq t_{ASC}(\max)$ and $t_{CP} \geq t_{CP}(\max)$
	$t_{ASC} \leq t_{CP}$ and $t_{CP} \leq t_{CP}(\max)$
t_{CAC}	$t_{ASC} \geq t_{ASC}(\max)$ and $t_{CP} \leq t_{CP}(\max)$

12c

μPD42273

Data Transfer Cycle. A data transfer is executed by bringing $\overline{DT}/\overline{OE}$ low as \overline{RAS} falls. $\overline{DT}/\overline{OE}$ must be low for a specified time, measured from \overline{RAS} and \overline{CAS} . The specified 1 of the possible 512 rows involved in the data transfer, as well as the starting location of the following serial read cycle, are defined by address inputs. The low-to-high transition of \overline{DT} causes column address buffer outputs to be transferred to the serial address counters, and storage cell data amplified on digit lines to be transferred to the data register. \overline{RAS} and \overline{CAS} must be low during these operations to keep the data in the random access port.

Serial Read Port

After the data transfer cycle, the serial read port is only used to serially read the contents of the data register starting from a specified location. The only condition

under which the serial read port must synchronize with the random access port is when the positive transition of $\overline{DT}/\overline{OE}$ must occur within a specified period in an SC cycle. Otherwise, the serial read port can operate asynchronously. Output data appears at SO_i after an access time of t_{SCA} , measured from SC high, only when \overline{SOE} is maintained low. The SC cycle which includes the positive transition of $\overline{DT}/\overline{OE}$ shows old data in the data register; subsequent SC cycles show new data transferred to the data register serially and in a looped manner. The serial output is maintained until the next SC signal is activated. \overline{SOE} controls the impedance of the serial output to allow multiplexing of more than one bank of μPD42273 graphics buffers into the same external circuitry. When \overline{SOE} is at a low logic level, SO_i is enabled and the proper data is read. When \overline{SOE} is high, SO_i is disabled and in a state of high impedance.

Power Supply Current

$T_A = 0$ to $+70^\circ\text{C}$; $V_{CC} = +5.0\text{ V} \pm 10\%$; $GND = 0\text{ V}$

Port Operation		Parameter	μPD42273-10	μPD42273-12	Unit	Test Conditions
Random Access	Serial Read		(max)	(max)		
Read/write cycle	Standby	I_{CC1}	95	85	mA	\overline{RAS} , \overline{CAS} cycling; $t_{RC} = t_{RC\ min}$; $\overline{SOE} = V_{IH}$; $SC = V_{IH}$ or V_{IL}
Standby	Standby	I_{CC2}	4	4	mA	$\overline{CAS} = \overline{RAS} = V_{IH}$; $\overline{SOE} = V_{IH}$; $SC = V_{IH}$ or V_{IL}
\overline{RAS} -only refresh cycle	Standby	I_{CC3}	95	85	mA	\overline{RAS} cycling; $\overline{CAS} = V_{IH}$; $t_{RC} = t_{RC\ min}$; $\overline{SOE} = V_{IH}$; $SC = V_{IH}$ or V_{IL} (Note 2)
Fast-page cycle	Standby	I_{CC4}	90	80	mA	$\overline{RAS} = V_{IL}$; \overline{CAS} cycling; $t_{PC} = t_{PC\ min}$; $\overline{SOE} = V_{IH}$; $SC = V_{IH}$ or V_{IL} (Note 3)
\overline{CAS} before \overline{RAS} refresh cycle	Standby	I_{CC5}	95	85	mA	\overline{CAS} low as \overline{RAS} falls; $t_{RC} = t_{RC\ min}$; $\overline{SOE} = V_{IH}$; $SC = V_{IH}$ or V_{IL}
Data transfer cycle	Standby	I_{CC6}	135	120	mA	\overline{DT} low as \overline{RAS} falls; $t_{RC} = t_{RC\ min}$; $\overline{SOE} = V_{IH}$; $SC = V_{IH}$ or V_{IL}
Read/write cycle	Active	I_{CC7}	120	105	mA	\overline{RAS} and \overline{CAS} cycling; $t_{RC} = t_{RC\ min}$; $\overline{SOE} = V_{IL}$; SC cycling; $t_{SCC} = t_{SCC\ min}$
Standby	Active	I_{CC8}	30	25	mA	$\overline{CAS} = \overline{RAS} = V_{IH}$; $\overline{SOE} = V_{IL}$; SC cycling; $t_{SCC} = t_{SCC\ min}$
\overline{RAS} -only refresh cycle	Active	I_{CC9}	120	105	mA	\overline{RAS} cycling; $\overline{CAS} = V_{IH}$; $t_{RC} = t_{RC\ min}$; $\overline{SOE} = V_{IL}$; SC cycling; $t_{SCC} = t_{SCC\ min}$
Fast-page cycle	Active	I_{CC10}	115	100	mA	$\overline{RAS} = V_{IL}$; \overline{CAS} cycling; $t_{PC} = t_{PC\ min}$; $\overline{SOE} = V_{IL}$; SC cycling; $t_{SCC} = t_{SCC\ min}$ (Note 3)
\overline{CAS} before \overline{RAS} refresh cycle	Active	I_{CC11}	120	105	mA	\overline{CAS} low as \overline{RAS} falls; $t_{RC} = t_{RC\ min}$; $\overline{SOE} = V_{IL}$; SC cycling; $t_{SCC} = t_{SCC\ min}$
Data transfer cycle	Active	I_{CC12}	160	140	mA	\overline{DT} low as \overline{RAS} falls; $t_{RC} = t_{RC\ min}$; $\overline{SOE} = V_{IL}$; SC cycling; $t_{SCC} = t_{SCC\ min}$

Notes:

- (1) No load on IO_i or SO_i . Except for I_{CC2} , I_{CC3} , I_{CC6} , and I_{CC14} , real values depend on output loading in addition to cycle rates.
- (2) \overline{CAS} is not clocked, but is kept at a stable high level. Column addresses are also assumed to be at a stable high or low level.

- (3) A change in column addresses must not occur more than once in a fast-page cycle.

DC Characteristics $T_A = 0 \text{ to } +70^\circ\text{C}; V_{CC} = +5.0 \text{ V} \pm 10\%; \text{GND} = 0 \text{ V}$

Parameter	Symbol	Min	Typ	Max	Unit	Test Conditions
Input leakage current	I_{IL}	-10		10	μA	$V_{IN} = 0 \text{ to } 5.5 \text{ V};$ all other pins not under test = 0 V
Output leakage current	I_{OL}	-10		10	μA	$D_{OUT} (IO_i, SO_i)$ disabled; $V_{OUT} = 0 \text{ to } 5.5 \text{ V}$
Random access port output voltage, high	$V_{OH(R)}$	2.4			V	$I_{OH(R)} = -2 \text{ mA}$
Random access port output voltage, low	$V_{OL(R)}$			0.4	V	$I_{OL(R)} = 4.2 \text{ mA}$
Serial read port output voltage, high	$V_{OH(S)}$	2.4			V	$I_{OH(S)} = -1 \text{ mA}$
Serial read port output voltage, low	$V_{OL(S)}$			0.4	V	$I_{OL(S)} = 2.1 \text{ mA}$

AC Characteristics $T_A = 0 \text{ to } +70^\circ\text{C}; V_{CC} = +5.0 \text{ V} \pm 10\%; \text{GND} = 0 \text{ V}$

Parameter	Symbol	μPD42273-10		μPD42273-12		Unit	Test Conditions
		Min	Max	Min	Max		
Switching Characteristics							
Access time from $\overline{\text{RAS}}$	t_{RAC}		100		120	ns	(Notes 3, 4 and 12)
Access time from falling edge of $\overline{\text{CAS}}$	t_{CAC}		25		30	ns	(Notes 3, 4, 13, 14 and 15)
Access time from column address	t_{AA}		55		65	ns	(Notes 3, 4, 14 and 15)
Access time from rising edge of $\overline{\text{CAS}}$	t_{ACP}		55		65	ns	(Notes 3 and 4)
Access time from $\overline{\text{OE}}$	t_{OEA}		25		30	ns	(Notes 3 and 4)
Serial output access time from SC	t_{SCA}		30		40	ns	(Notes 3 and 18)
Serial output access time from $\overline{\text{SOE}}$	t_{SOA}		25		30	ns	(Note 3)
Output disable time from $\overline{\text{CAS}}$ high	t_{OFF}	0	25	0	30	ns	(Note 5)
Output disable time from $\overline{\text{OE}}$ high	t_{OEZ}	0	25	0	30	ns	(Note 5)
Serial output disable time from $\overline{\text{SOE}}$ high	t_{SOZ}	0	15	0	20	ns	(Note 5)
$\overline{\text{SOE}}$ low to serial output setup delay	t_{SOO}	5		5		ns	
Serial output hold time after SC high	t_{SOH}	5		5		ns	
Timing Requirements							
Random read or write cycle time	t_{RC}	190		220		ns	(Note 11)
Read-write/read-modify-write cycle time	t_{RWC}	255		295		ns	(Note 11)
Fast-page cycle time	t_{PC}	60		70		ns	(Note 11)
Fast-page read-write/read-modify-write cycle time	t_{PRWC}	125		145		ns	(Note 11)
Rise and fall transition time	t_T	3	50	3	50	ns	(Notes 3, 10 and 18)
$\overline{\text{RAS}}$ precharge time	t_{RP}	80		90		ns	(Note 18)
$\overline{\text{RAS}}$ pulse width	t_{RAS}	100	10,000	120	10,000	ns	
Fast-page $\overline{\text{RAS}}$ pulse width	t_{RASp}	100	100,000	120	100,000	ns	
$\overline{\text{RAS}}$ hold time	t_{RSH}	25		30		ns	
$\overline{\text{CAS}}$ precharge time (nonpage cycle)	t_{CPN}	10		15		ns	
Fast-page $\overline{\text{CAS}}$ precharge time	t_{CP}	10	25	15	30	ns	
$\overline{\text{CAS}}$ pulse width	t_{CAS}	25	10,000	30	10,000	ns	
$\overline{\text{CAS}}$ hold time	t_{CSH}	100		120		ns	
$\overline{\text{RAS}}$ to $\overline{\text{CAS}}$ delay	t_{RCD}	25	75	25	90	ns	(Note 4)
$\overline{\text{CAS}}$ high to $\overline{\text{RAS}}$ low precharge time	t_{CRP}	10		10		ns	(Note 16)

μPD42273

AC Characteristics (cont)

Parameter	Symbol	μPD42273-10		μPD42273-12		Unit	Test Conditions
		Min	Max	Min	Max		
Timing Requirements (cont)							
Row address setup time	t _{ASR}	0		0		ns	
Row address hold time	t _{RAH}	12		15		ns	
Column address setup time	t _{ASC}	0	25	0	30	ns	(Note 15)
Column address hold time	t _{CAH}	15		20		ns	
RAS to column address delay time	t _{RAD}	17	45	20	55	ns	(Notes 9 and 14)
Column address to RAS lead time	t _{RAL}	55		65		ns	
Read command setup time	t _{RCS}	0		0		ns	
Read command hold time after RAS high	t _{RRH}	10		10		ns	(Note 6)
Read command hold time after CAS high	t _{RCH}	0		0		ns	(Note 6)
Write command setup time	t _{WCS}	0		0		ns	(Note 7)
Write command hold time	t _{WCH}	20		30		ns	
Write command pulse width	t _{WP}	20		25		ns	(Note 17)
Write command to RAS lead time	t _{RWL}	30		35		ns	
Write command to CAS lead time	t _{CWL}	30		35		ns	
Data-in setup time	t _{DS}	0		0		ns	(Note 8)
Data-in hold time	t _{DH}	20		25		ns	(Note 8)
Column address to WE delay	t _{AWD}	85		100		ns	(Note 7)
CAS to WE delay	t _{CWD}	55		65		ns	(Note 7)
RAS to WE delay	t _{RWD}	130		155		ns	(Note 7)
OE high to data-in setup delay	t _{OED}	30		35		ns	
OE high hold time after WE low	t _{OEH}	25		30		ns	
CAS before RAS refresh setup time	t _{CSR}	0		0		ns	
CAS before RAS refresh hold time	t _{CHR}	15		20		ns	
RAS high to CAS low precharge time	t _{RPC}	0		0		ns	
Refresh interval	t _{REF}		8		8	ms	Addresses A ₀ through A ₈
DT low setup time	t _{DLS}	0		0		ns	
DT low hold time after RAS low	t _{RDH}	80		90		ns	(Note 18)
DT low hold time after CAS low	t _{CDH}	30		35		ns	
SC high to DT high delay	t _{SDD}	10		15		ns	
SC low hold time after DT high	t _{SDH}	10		15		ns	
Serial clock cycle time	t _{SCC}	30		40		ns	(Note 11)
SC pulse width	t _{SCH}	10		15		ns	
SC precharge time	t _{SCL}	10		15		ns	
DT high setup time	t _{DHS}	0		0		ns	
DT high hold time	t _{DHH}	15		20		ns	
DT high to RAS high delay	t _{DTR}	10		10		ns	
DT high to CAS high delay	t _{DTC}	5		5		ns	

AC Characteristics (cont)

Parameter	Symbol	μPD42273-10		μPD42273-12		Unit	Test Conditions
		Min	Max	Min	Max		
Timing Requirements (cont)							
OE to RAS inactive setup time	t _{OES}	10		10		ns	
Write-per-bit setup time	t _{WBS}	0		0		ns	
Write-per-bit hold time	t _{WBH}	15		20		ns	
Write bit selection setup time	t _{WS}	0		0		ns	
Write bit selection hold time	t _{WH}	15		20		ns	
SOE pulse width	t _{SOE}	10		15		ns	
SOE precharge time	t _{SOP}	10		15		ns	
DT high hold time after RAS high	t _{DT H}	15		20		ns	

Notes:

- (1) All voltages are referenced to GND.
- (2) An initial pause of 100 μs is required after power-up, followed by any eight RAS cycles and four data transfer (DT) cycles, before proper device operation is achieved.
- (3) See input/output timing waveforms for timing reference voltages. See figures 3 and 4 for output loads.
- (4) Operation within the t_{RCD} (max) limit ensures that t_{RAC} (max) can be met. The t_{RCD} (max) limit is specified as a reference point only. If t_{RCD} is greater than the specified t_{RCD} (max) limit, access time is controlled exclusively by t_{CAC}, t_{OEA}, or t_{AA}.
- (5) An output disable time defines the time at which the output achieves the open-circuit condition and is not referenced to output voltage levels.
- (6) Either t_{RRH} or t_{RCH} must be satisfied for a read cycle.
- (7) t_{WCS}, t_{AWD}, t_{CWD}, and t_{RWD} are restrictive operating parameters in read-write and read-modify-write cycles only. If t_{WCS} ≥ t_{WCS} (min), the cycle is an early write cycle and the data output will remain open-circuit throughout the entire cycle. If t_{AWD} ≥ t_{AWD} (min), t_{CWD} ≥ t_{CWD} (min), and t_{RWD} ≥ t_{RWD} (min), the cycle is a read-write cycle and the data output will contain data read from the selected cell. If neither of the above conditions is met, the condition of the data out (at access time and until CAS returns to V_{IH}) is indeterminate.
- (8) These parameters are referenced to the falling edge of CAS in early write cycles and to the falling edge of (WB)/WE in delayed write or read-modify-write cycles.
- (9) Assumes that t_{RAD} (min) = t_{RAH} (min) + typical t_T of 5 ns.
- (10) V_{IH} (min) and V_{IL} (max) are reference levels for measuring the timing of input signals. Additionally, transition times are measured between V_{IH} and V_{IL}.
- (11) The minimum specifications are used only to indicate the cycle time at which proper operation over the full temperature range (T_A = 0 to +70°C) is assured.
- (12) Assumes that t_{RCD} ≤ t_{RCD} (max) and t_{RAD} ≤ t_{RAD} (max). If t_{RCD} or t_{RAD} is greater than the maximum recommended value in this table, t_{RAC} increases by the amount that t_{RCD} or t_{RAD} exceeds the value shown.
- (13) Assumes that t_{RCD} ≥ t_{RCD} (max) and t_{RAD} ≤ t_{RAD} (max).
- (14) If t_{RAD} ≥ t_{RAD} (max), then the access time is defined by t_{AA}.
- (15) For fast-page read operation, the definition of access time is as follows.

CAS and Column Address Input Conditions	Access Time Definition
t _{CP} ≤ t _{CP} (max), t _{ASC} ≥ t _{CP}	t _{ACP}
t _{CP} ≤ t _{CP} (max), t _{ASC} ≤ t _{CP}	t _{AA}
t _{CP} ≥ t _{CP} (max), t _{ASC} ≤ t _{ASC} (max)	t _{AA}
t _{CP} ≥ t _{CP} (max), t _{ASC} ≥ t _{ASC} (max)	t _{CAC}

- (16) The t_{CRP} requirement is applicable for RAS/CAS cycles preceded by any cycle.
- (17) Parameter t_{WP} is applicable for a delayed write cycle such as a read-write/read-modify-write cycle. For early write operation, both t_{WCS} and t_{WCH} must be met.
- (18) Improvement in parameters t_{RDH}, t_{RP} and t_{SCA} are planned for process versions "x" and "m". Please contact your NEC sales office for details.
- (19) Ac measurements assume t_T = 5 ns.

12c

12c-9

μPD42273

Figure 1. Input Timing

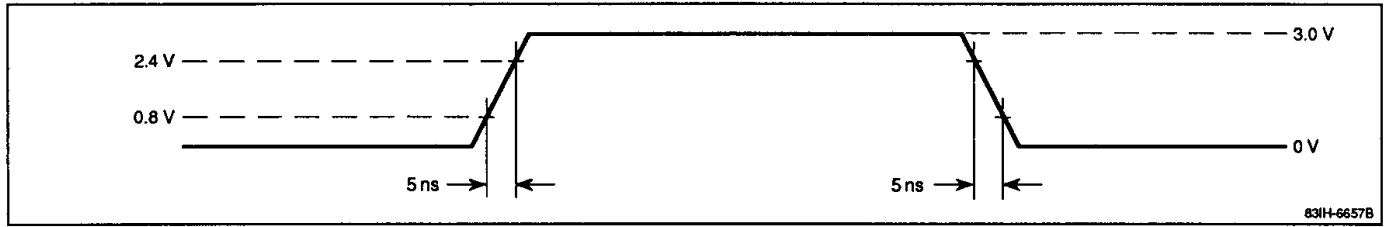

Figure 2. Output Timing

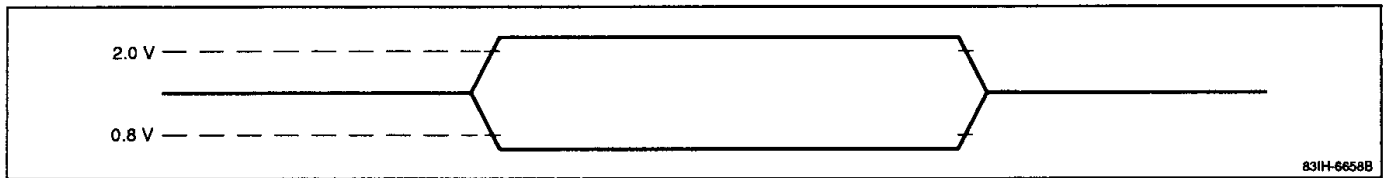

Figure 3. Output Load in Random Access Port

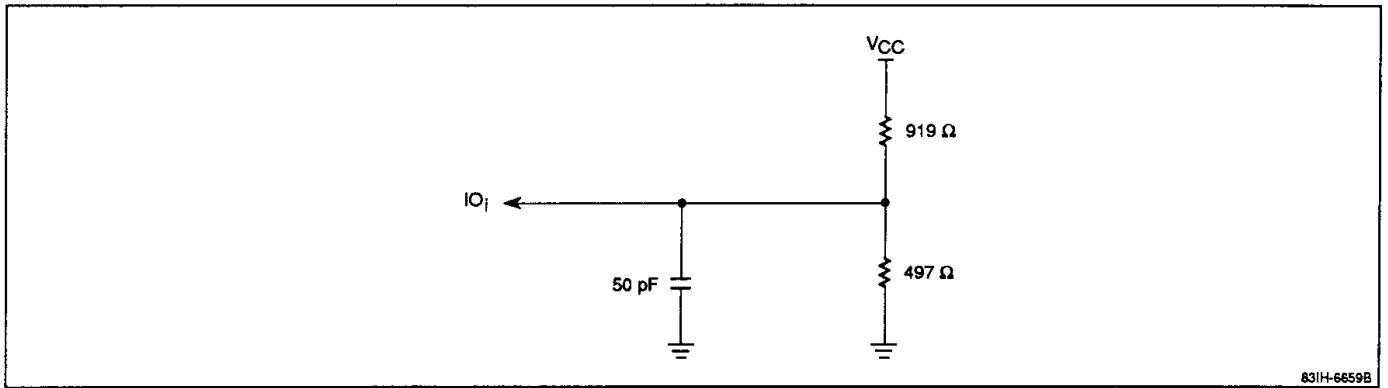
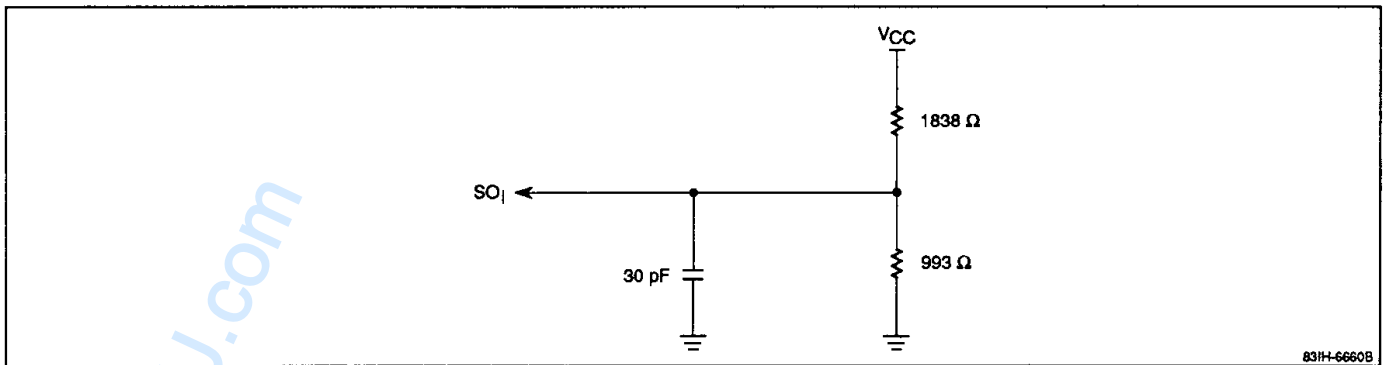
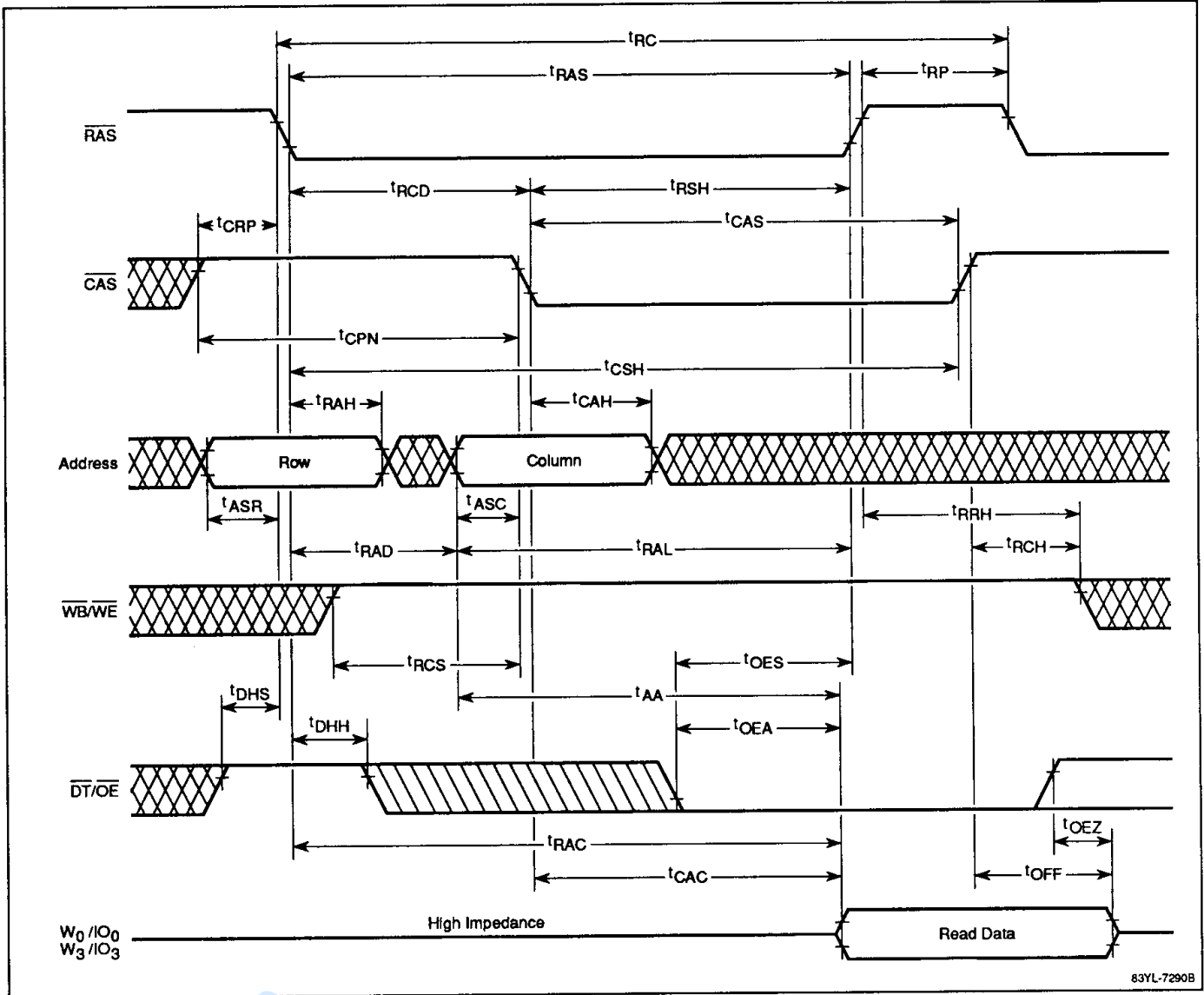

Figure 4. Output Load in Serial Read Port



Timing Waveforms

Read Cycle



12c

83YL-7290B

www.DataSheet4U.com

μPD42273

Timing Waveforms (cont)

Early Write Cycle

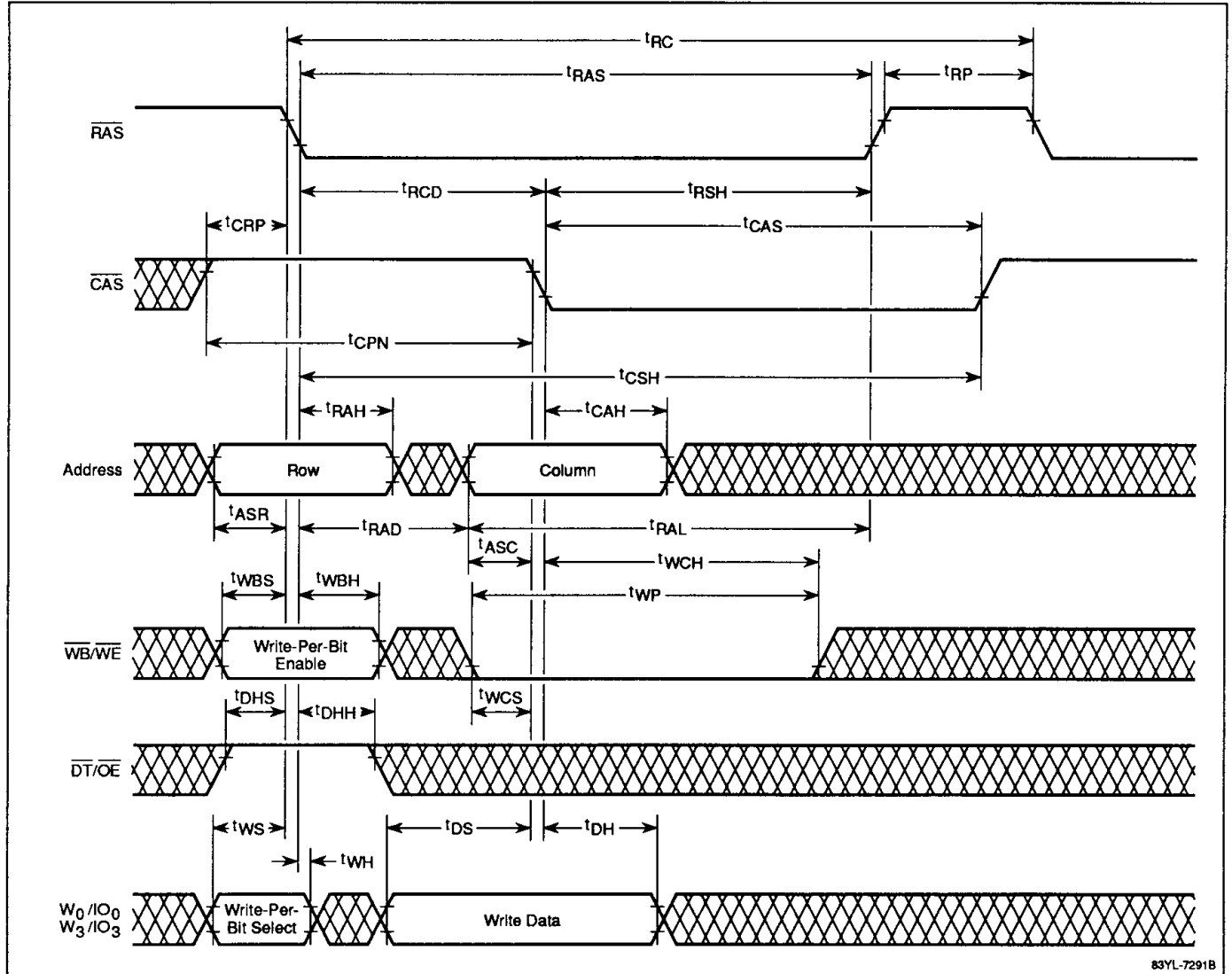

Timing Waveforms (cont)

Late Write Cycle

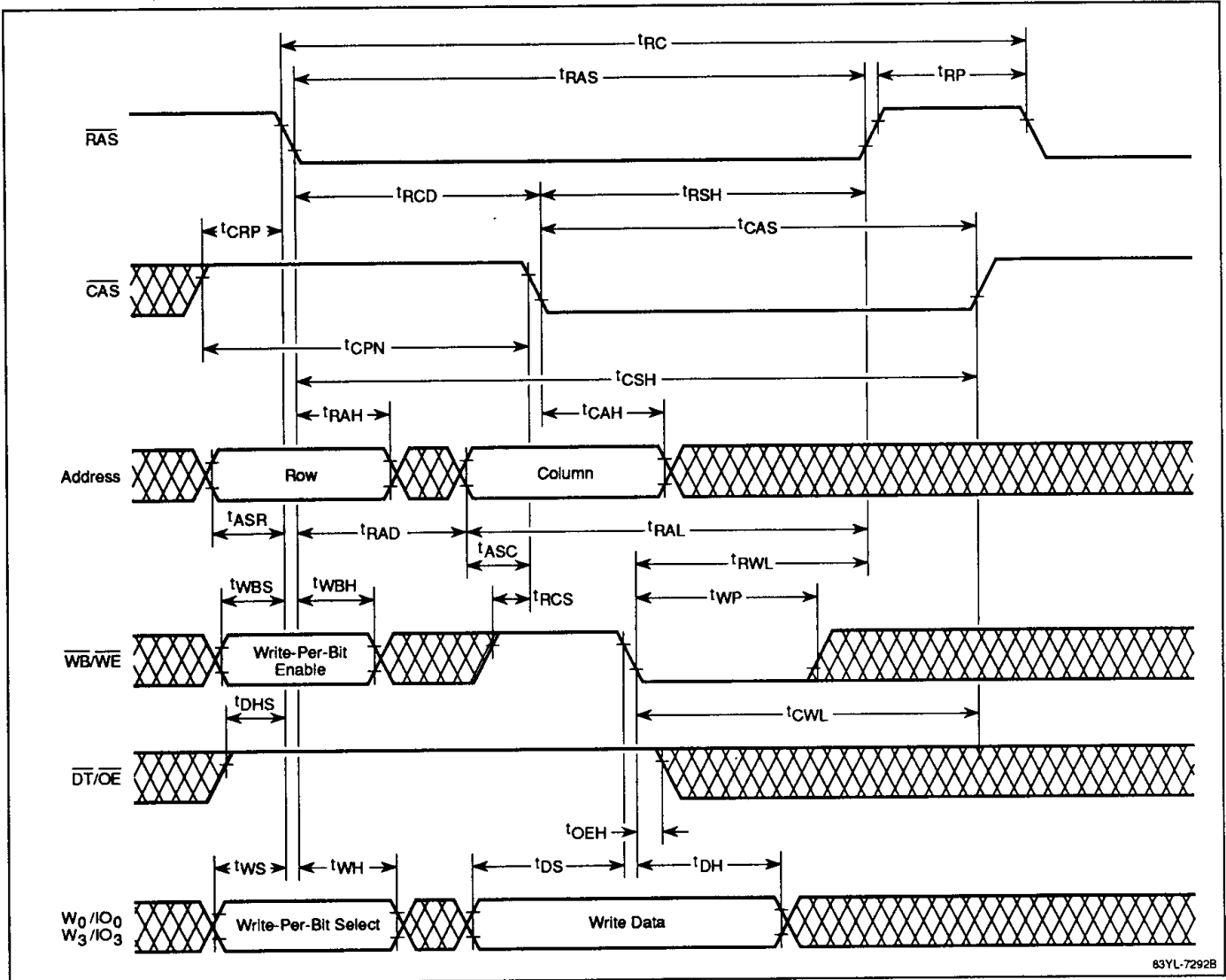

12c

www.DataSheet4U.com

μPD42273

Timing Waveforms (cont)

Read-Write/Read-Modify-Write Cycle

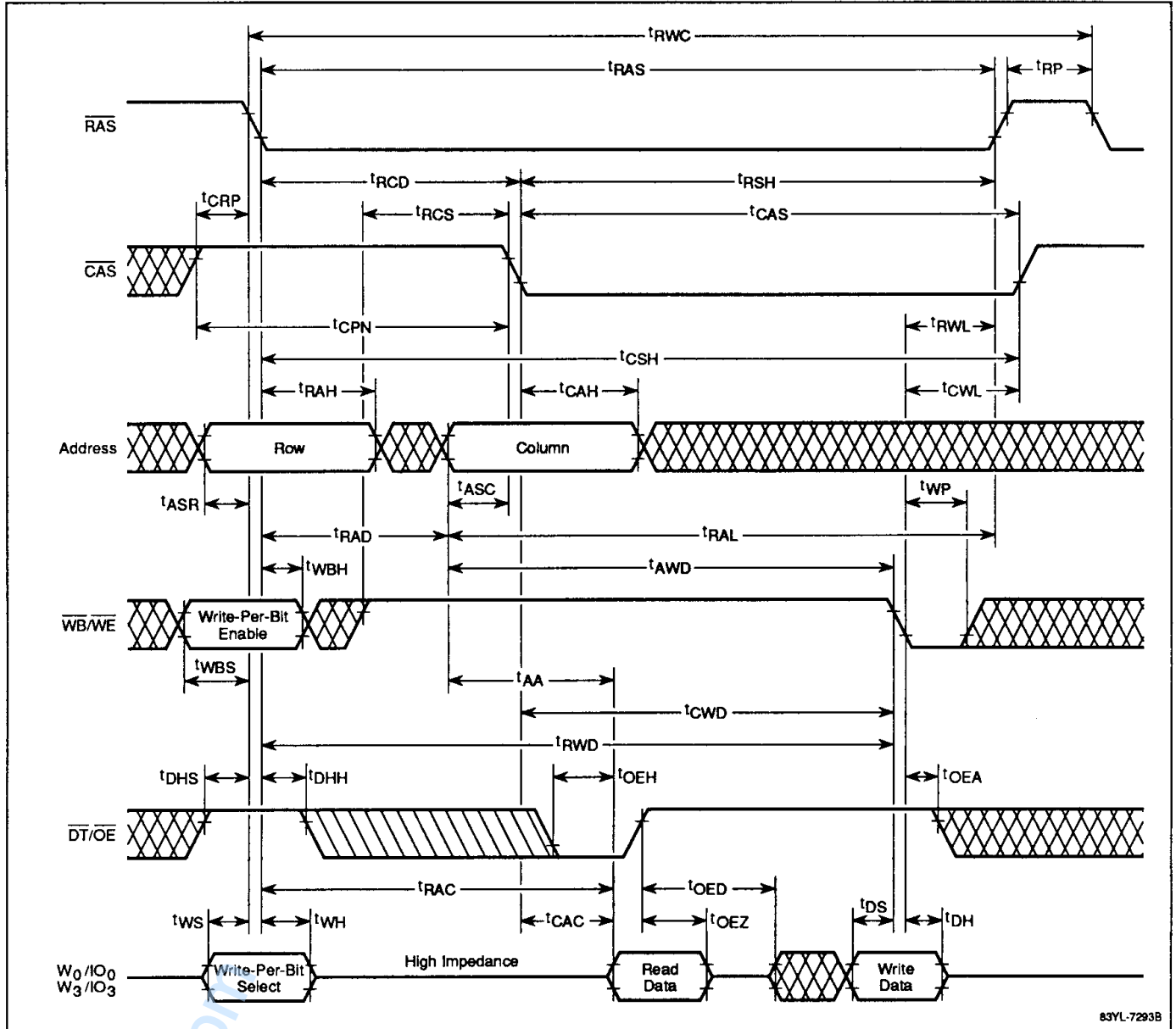

83YL-7293B

www.DataSheet4U.com

Timing Waveforms (cont)

RAS-Only Refresh Cycle

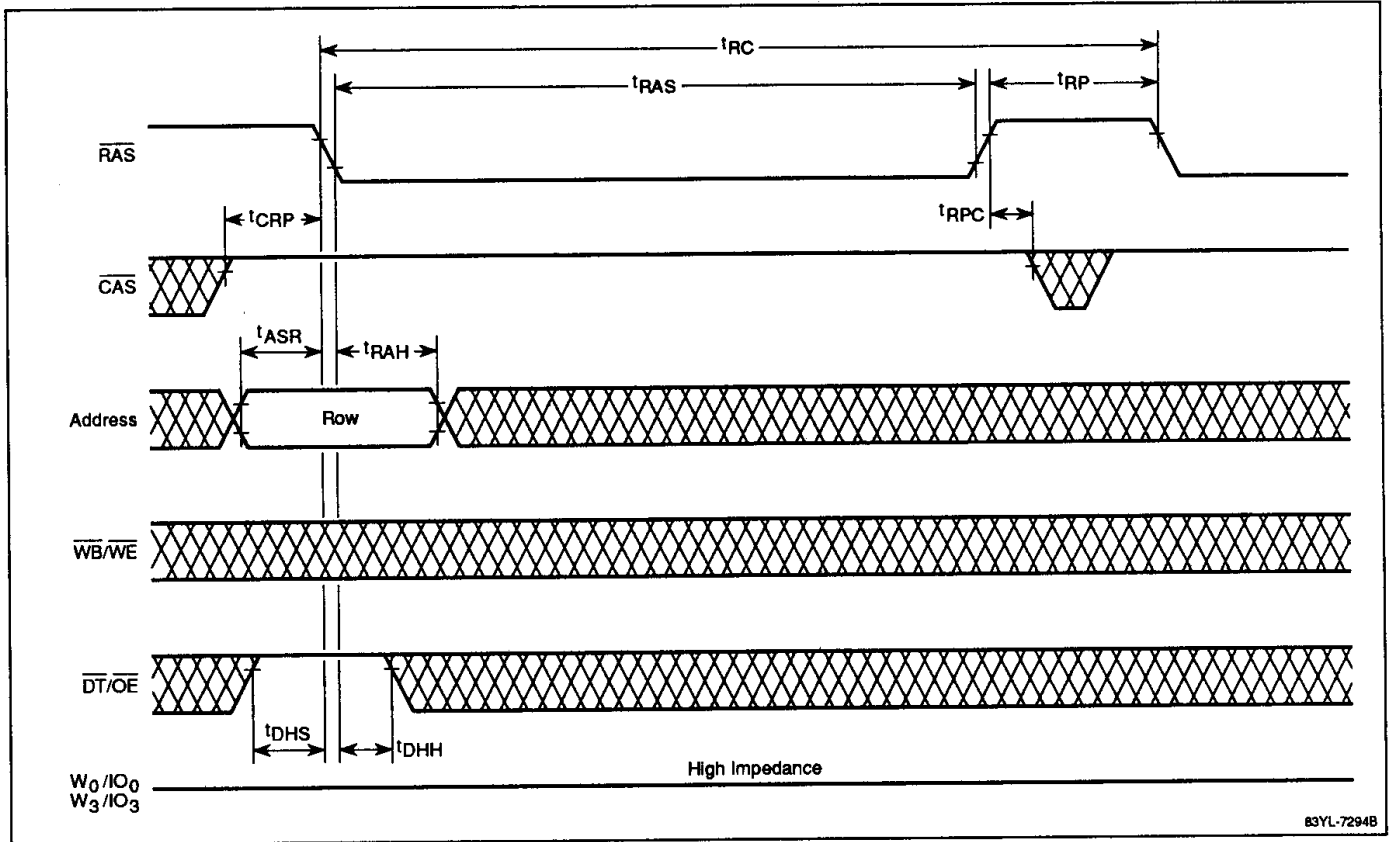

12c

www.DataSheet4U.com

μ PD42273

Timing Waveforms (cont)

$\overline{\text{CAS}}$ Before $\overline{\text{RAS}}$ Refresh Cycle

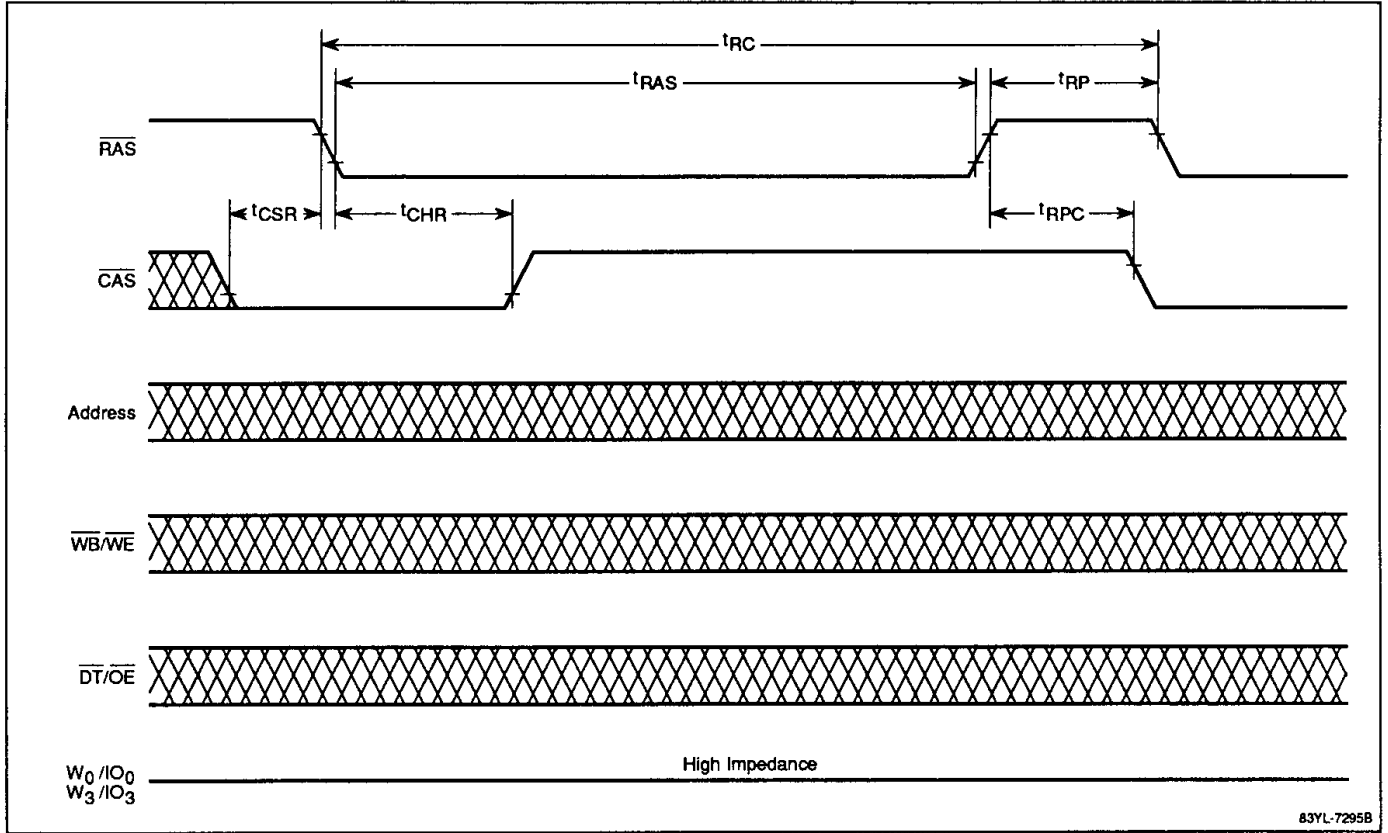

83YL-7295B

Timing Waveforms (cont)

Hidden Refresh Cycle

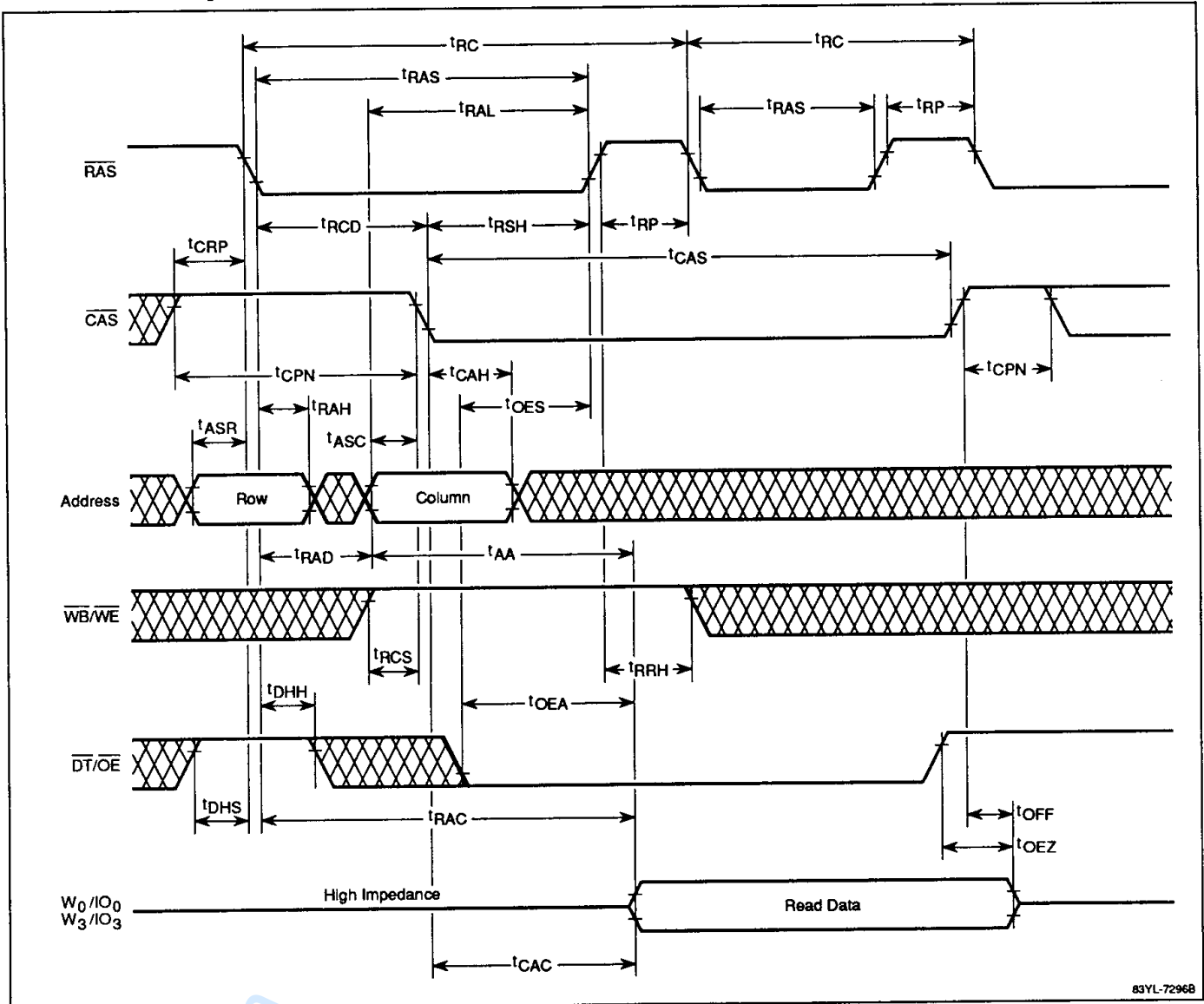

12c

83YL-7296B

www.DataSheet4U.com

μPD42273

Timing Waveforms (cont)

Fast-Page Read Cycle

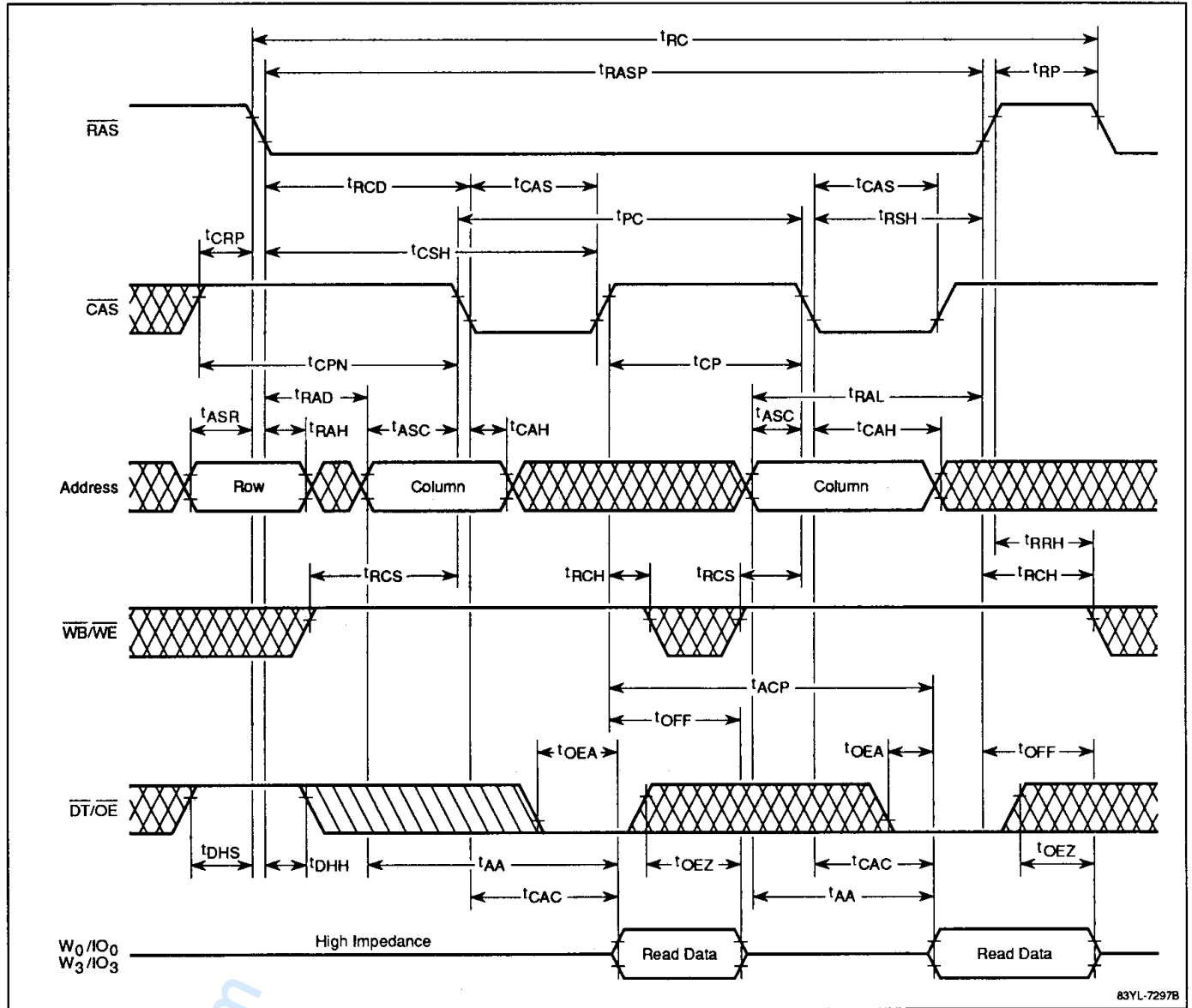

83YL-7297B

Timing Waveforms (cont)

Fast-Page Write Cycle

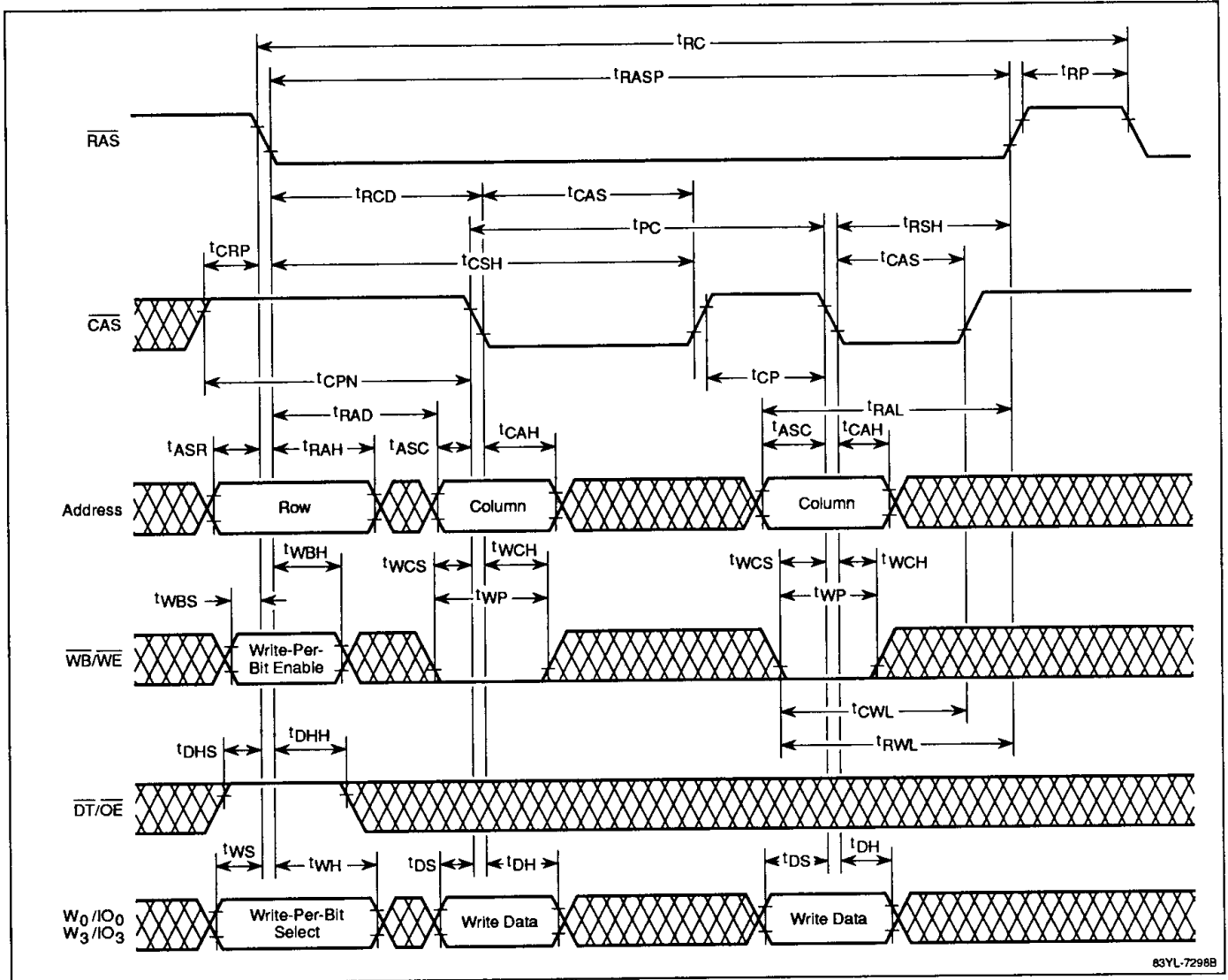

12c

83YL-7298B

www.DataSheet4U.com

μ PD42273

Timing Waveforms (cont)

Fast-Page Read-Modify-Write Cycle

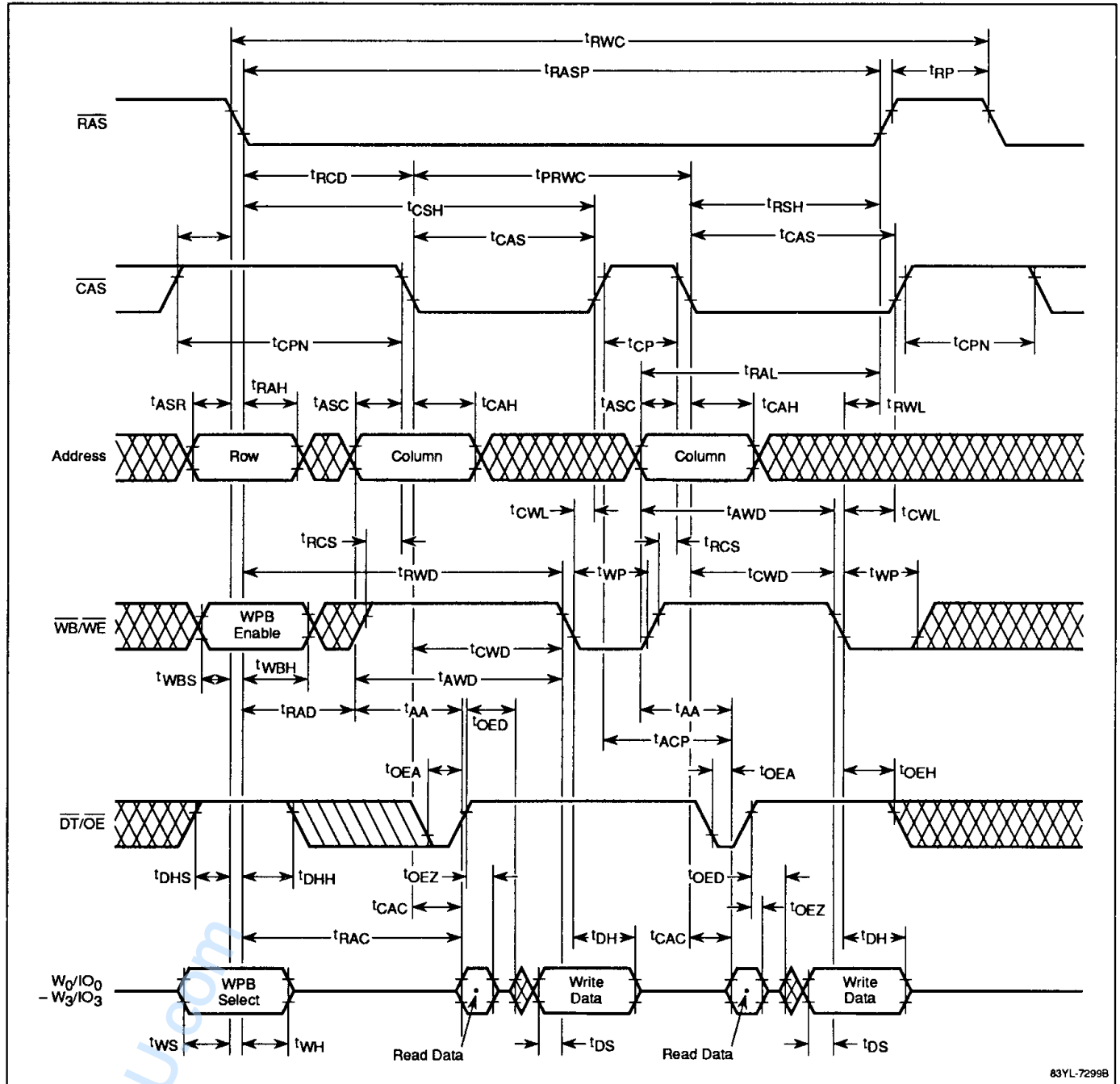

Timing Waveforms (cont)

Data Transfer Cycle with Serial Port Active

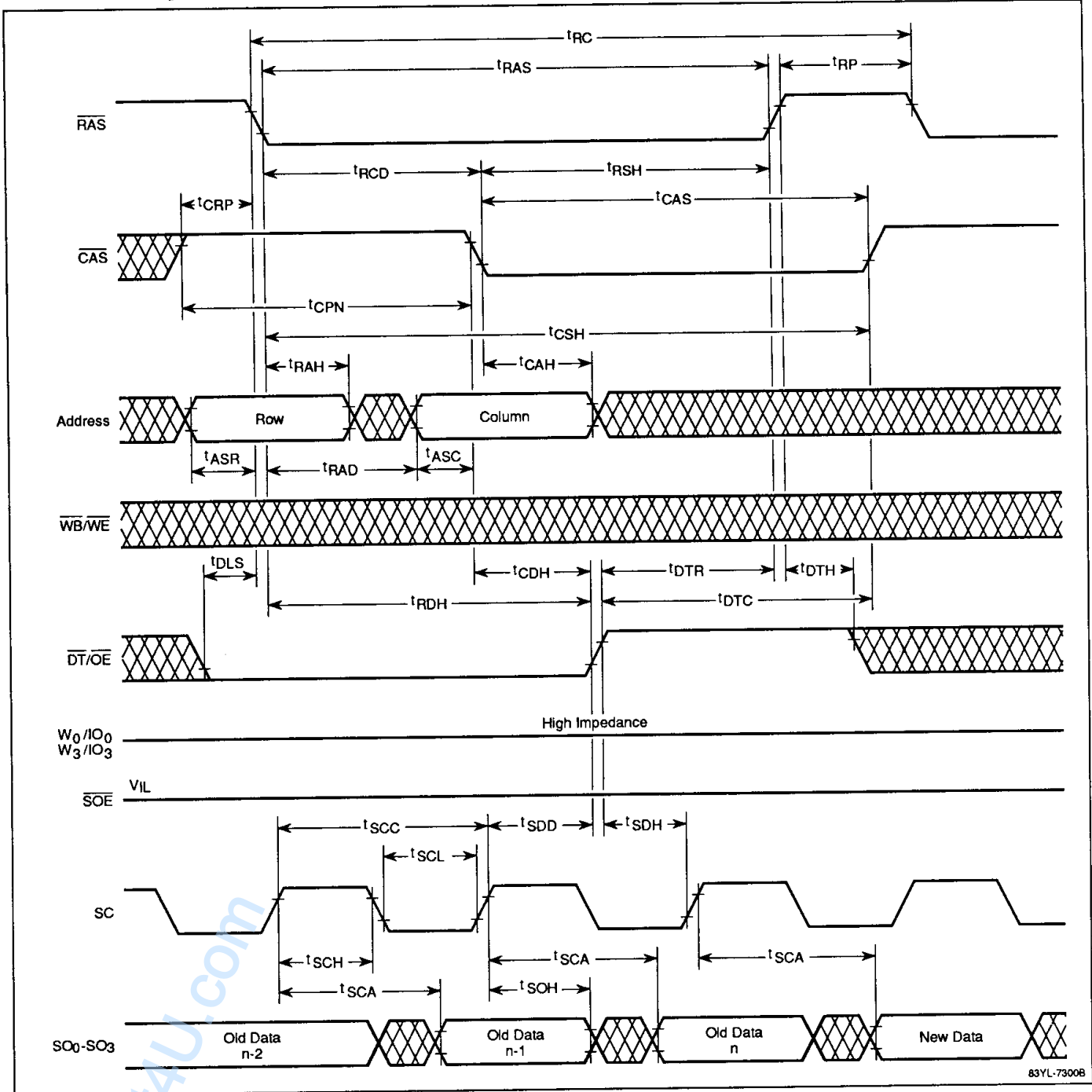

12c

83YL-73008

μ PD42273

Timing Waveforms (cont)

Data Transfer Cycle with Serial Port in Standby

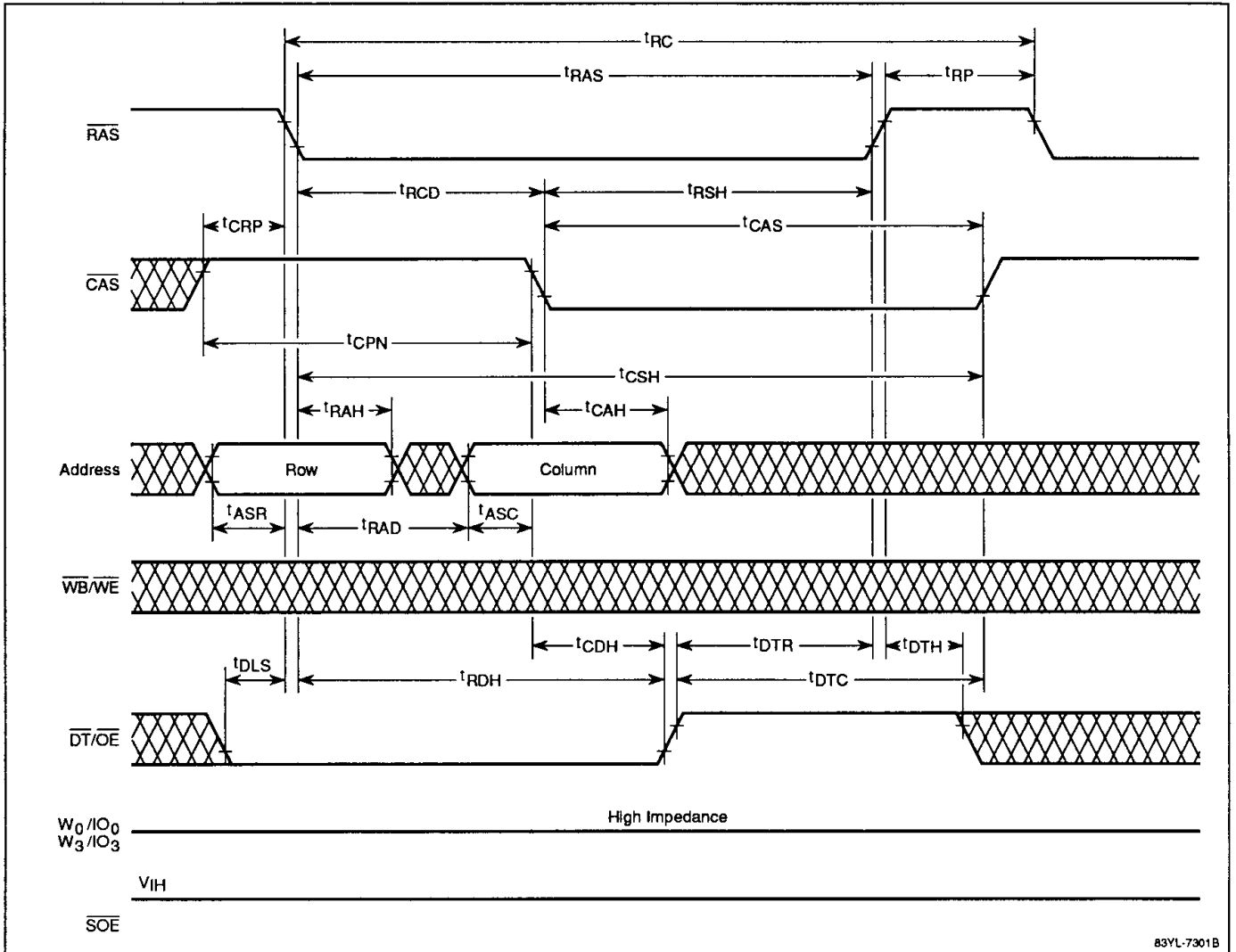

83YL-7301B

Timing Waveforms (cont)

Serial Read Cycle

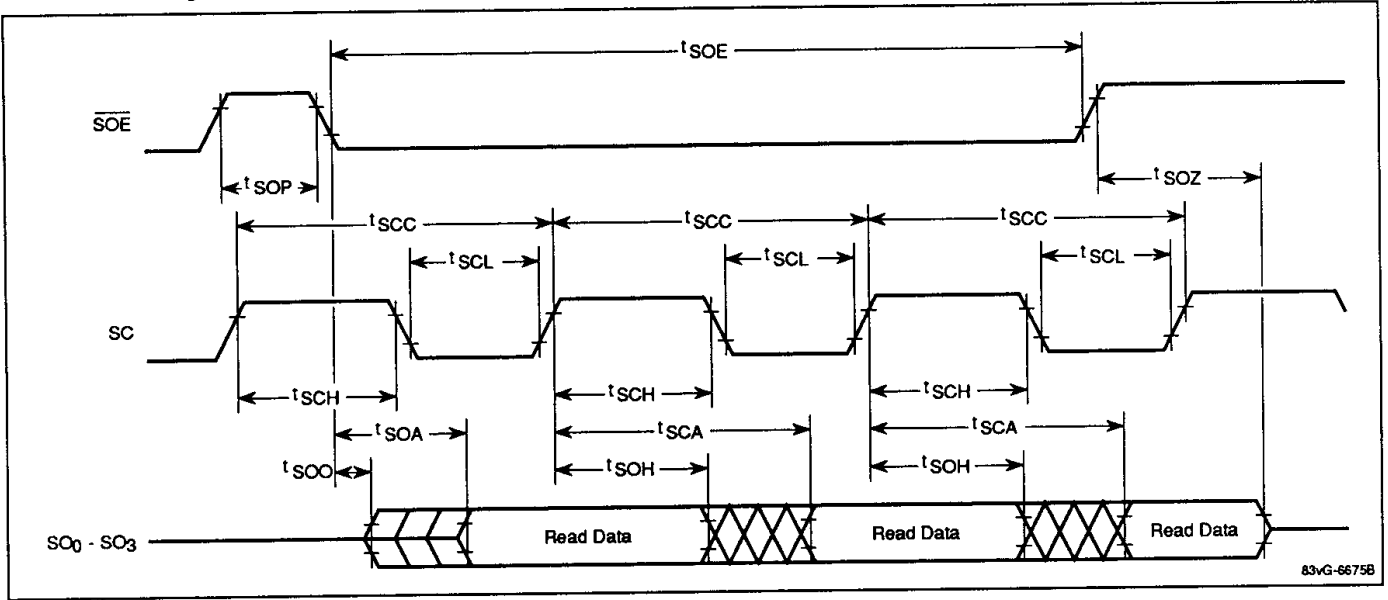

12c

www.DataSheet4U.com