

T-46-23-17

Description

The μ PD424280A/L and μ PD42S4280A/L are fast-page dynamic RAMs organized as 262,144 words by 18 bits and designed to operate from a single power supply.

Optional features are power supply voltage (+5 V or +3.3 V) and a new refresh mode called "self-refresh."

μ PD	Options
424280A	+5 V
424280L	+3.3 V
42S4280A	+5 V; self-refresh mode
42S4280L	+3.3 V; self-refresh mode

Advanced polycide technology using stacked capacitors minimizes silicon area and provides high storage cell capacity, high performance, and high reliability. A single-transistor dynamic storage cell and CMOS circuitry throughout ensure minimum power dissipation, while an on-chip circuit internally generates the negative-voltage substrate bias—automatically and transparently.

The three-state I/O pins are controlled by $\overline{\text{UCAS}}$ and $\overline{\text{LCAS}}$ independent of $\overline{\text{RAS}}$. After a valid read or read-modify-write cycle, upper or lower byte data is held on the outputs by maintaining $\overline{\text{UCAS}}$ or $\overline{\text{LCAS}}$ low. Data outputs return to high impedance when either $\overline{\text{UCAS}}$ or $\overline{\text{LCAS}}$ goes high. Fast-page read and write cycles can be executed by cycling $\overline{\text{UCAS}}$ or $\overline{\text{LCAS}}$.

Refreshing may be accomplished by a $\overline{\text{CAS}}$ before $\overline{\text{RAS}}$ refresh cycle (CBR) that internally generates the refresh address. $\overline{\text{RAS}}$ -only refresh cycles will also refresh all memory locations.

The self-refresh mode is entered by holding $\overline{\text{RAS}}$ low for longer than 100 μ s during a CBR cycle. Detection of this long $\overline{\text{RAS}}$ time starts an internal oscillator that maintains data integrity without external clocking. The slow refresh reduces the data hold current to less than 200 microamperes. Self-refresh mode is used with microprocessors that have a "sleep mode" for low-power applications such as notebook PCs.

Features

- 262,144 by 18-bit organization
- Single power supply (+5-volt or +3.3-volt)
- Self-refresh option (slow internal automatic refresh)
- Fast-page option
- Byte read/write control with $\overline{\text{UCAS}}$ and $\overline{\text{LCAS}}$

- Low power dissipation
- $\overline{\text{CAS}}$ before $\overline{\text{RAS}}$ refreshing
- On-chip substrate bias generator
- TTL-compatible inputs and outputs
- Nonlatched, three-state outputs
- Low input capacitance
- Multiplexed row and column addresses
- 512 refresh cycles every 8 ms
- 40-pin SOJ, 40-pin ZIP, and 44/40-pin TSOP plastic packaging

Pin Configurations

40-Pin Plastic SOJ

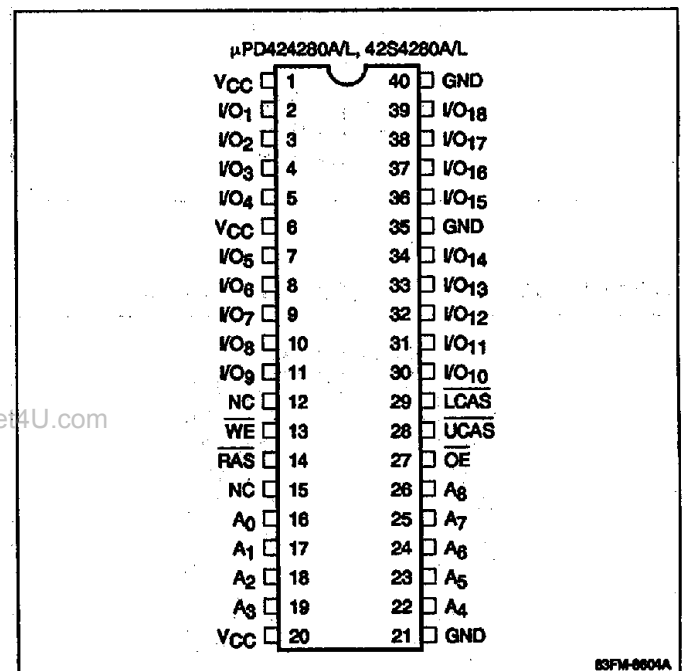

Pin Configurations (cont)

40-Pin Plastic ZIP

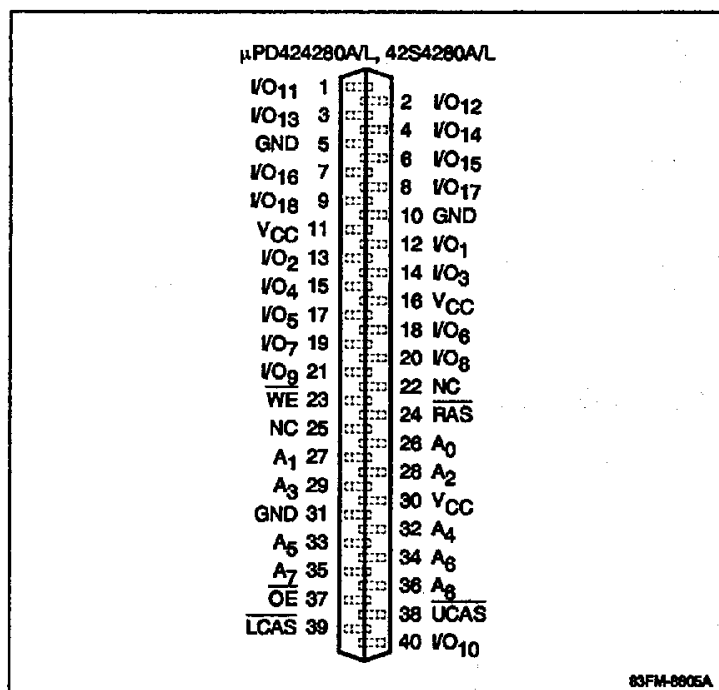

44/40-Pin Plastic TSOP (Reverse Pinouts)

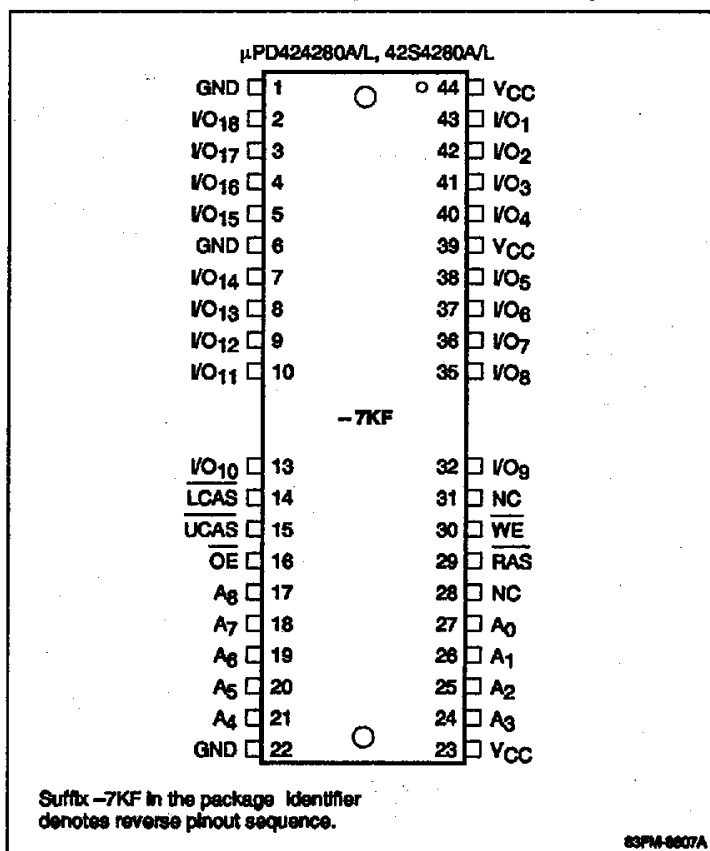

Suffix -7KF in the package identifier denotes reverse pinout sequence.

44/40-Pin Plastic TSOP (Normal Pinouts)

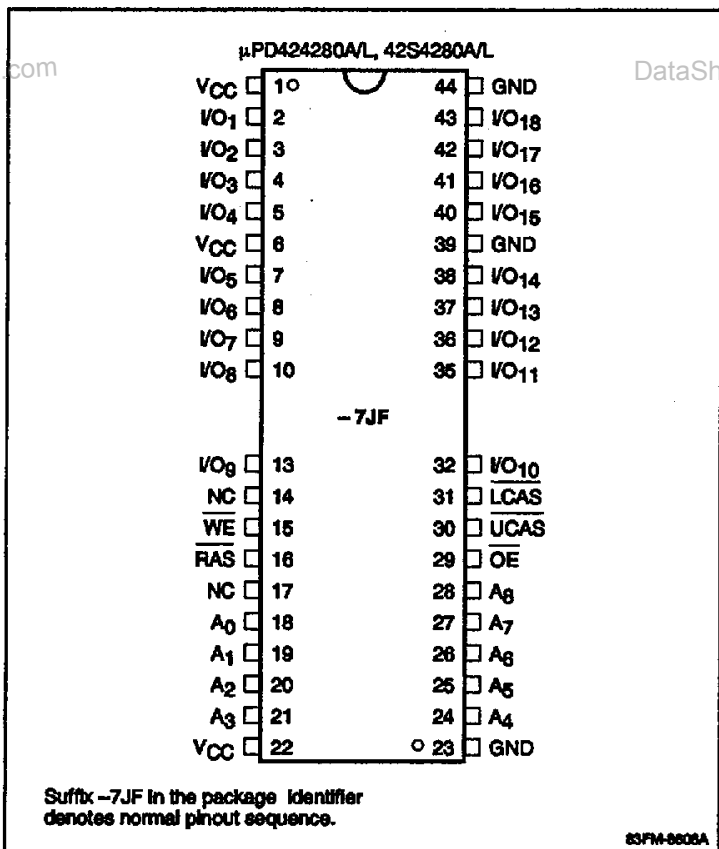

Suffix -7JF in the package identifier denotes normal pinout sequence.

Pin Identification

Name	Function
A ₀ - A ₈	Address inputs
IO ₁ - IO ₁₈	Data inputs and outputs
LCAS, UCAS	Column address strobes
OE	Output enable
RAS	Row address strobe
WE	Write enable
GND	Ground
VCC	+5-volt or +3.3-volt power supply
NC	No connection

Ordering Information, μ PD424280A (+ 5-volt power)

Part Number	RAS Access Time (max)	Fast-Page Cycle Time (max)	CAS Access Time (max)	Package
μ PD424280ALE-60	60 ns	40 ns	20 ns	40-pin plastic SOJ
LE-70	70 ns	45 ns		
LE-80	80 ns	50 ns		
μ PD424280AV-60	60 ns	40 ns	20 ns	40-pin plastic ZIP
V-70	70 ns	45 ns		
V-80	80 ns	50 ns		
μ PD424280AG5-60	60 ns	40 ns	20 ns	44/40-pin plastic TSOP (normal pinouts)
G5-70	70 ns	45 ns		
G5-80	80 ns	50 ns		
μ PD424280AG5M-60	60 ns	40 ns	20 ns	44/40-pin plastic TSOP (reverse pinouts)
G5M-70	70 ns	45 ns		
G5M-80	80 ns	50 ns		

Ordering Information, μ PD424280L (+ 3.3-volt power)

Part Number	RAS Access Time (max)	Fast-Page Cycle Time (max)	CAS Access Time (max)	Package
μ PD424280LLE-A60	60 ns	40 ns	20 ns	40-pin plastic SOJ
LE-A70	70 ns	45 ns		
LE-A80	80 ns	50 ns		
μ PD424280LV-A60	60 ns	40 ns	20 ns	40-pin plastic ZIP
V-A70	70 ns	45 ns		
V-A80	80 ns	50 ns		
μ PD424280LG5-A60	60 ns	40 ns	20 ns	44/40-pin plastic TSOP (normal pinouts)
G5-A70	70 ns	45 ns		
G5-A80	80 ns	50 ns		
μ PD424280LG5M-A60	60 ns	40 ns	20 ns	44/40-pin plastic TSOP (reverse pinouts)
G5M-A70	70 ns	45 ns		
G5M-A80	80 ns	50 ns		

Ordering Information, μPD42S4280A (+ 5-volt power; self-refresh mode)

Part Number	RAS Access Time (max)	Fast-Page Cycle Time (max)	CAS Access Time (max)	Self-Refresh Current (max)	Package
μPD42S4280ALE-60	60 ns	40 ns	20 ns	300 μA	40-pin plastic SOJ
LE-70	70 ns	45 ns			
LE-80	80 ns	50 ns			
μPD42S4280AV-60	60 ns	40 ns	20 ns	300 μA	40-pin plastic ZIP
V-70	70 ns	45 ns			
V-80	80 ns	50 ns			
μPD42S4280AG5-60	60 ns	40 ns	20 ns	300 μA	44/40-pin plastic TSOP (normal pinouts)
G5-70	70 ns	45 ns			
G5-80	80 ns	50 ns			
μPD42S4280AG5M-60	60 ns	40 ns	20 ns	300 μA	44/40-pin plastic TSOP (reverse pinouts)
G5M-70	70 ns	45 ns			
G5M-80	80 ns	50 ns			

Ordering Information, μPD42S4280L (+ 3.3-volt power; self-refresh mode)

Part Number	RAS Access Time (max)	Fast-Page Cycle Time (max)	CAS Access Time (max)	Self-Refresh Current (max)	Package
μPD42S4280LLE-A60	60 ns	40 ns	20 ns	100 μA	40-pin plastic SOJ
LE-A70	70 ns	45 ns			
LE-A80	80 ns	50 ns			
μPD42S4280LV-A60	60 ns	40 ns	20 ns	100 μA	40-pin plastic ZIP
V-A70	70 ns	45 ns			
V-A80	80 ns	50 ns			
μPD42S4280LG5-A60	60 ns	40 ns	20 ns	100 μA	44/40-pin plastic TSOP (normal pinouts)
G5-A70	70 ns	45 ns			
G5-A80	80 ns	50 ns			
μPD42S4280LG5M-A60	60 ns	40 ns	20 ns	100 μA	44/40-pin plastic TSOP (reverse pinouts)
G5M-A70	70 ns	45 ns			
G5M-A80	80 ns	50 ns			

Block Diagram

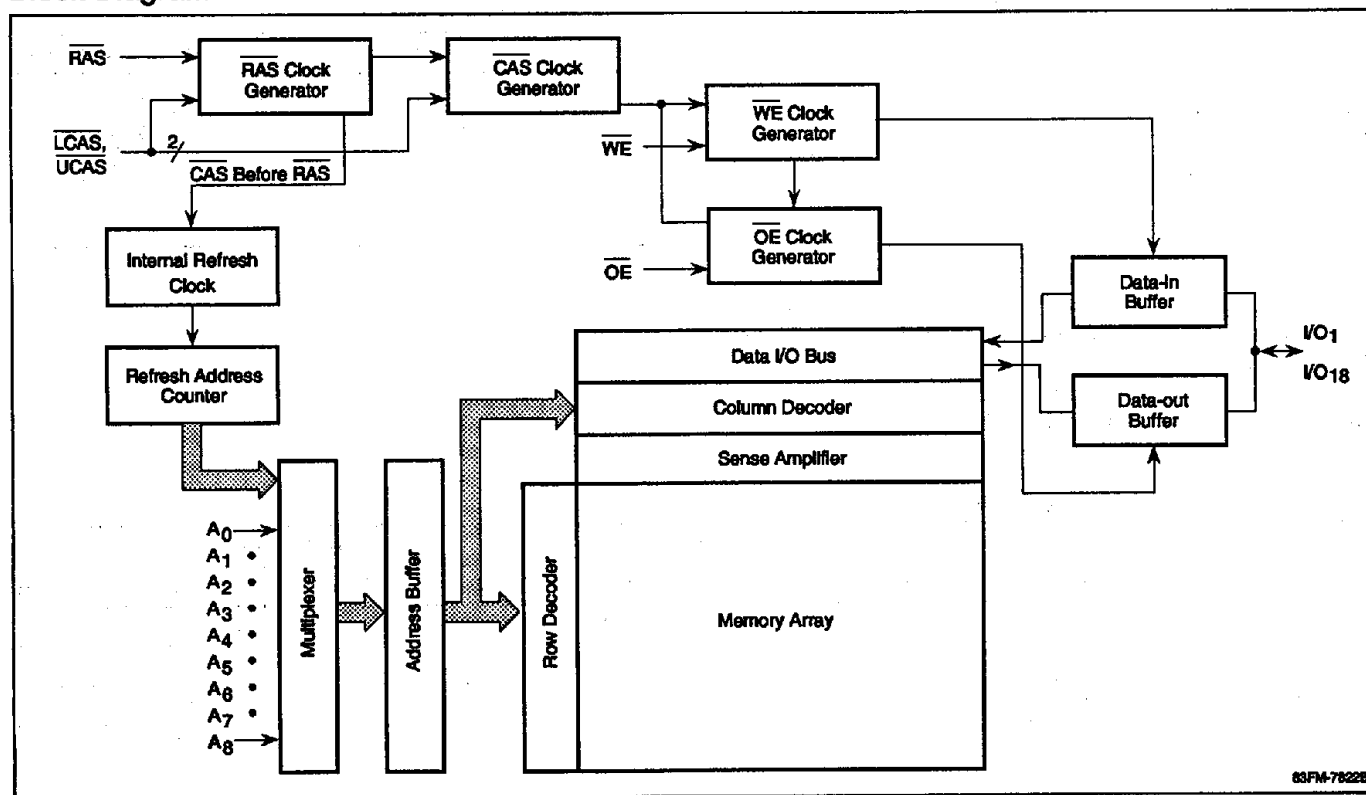

Truth Table

Function	RAS	LCAS	UCAS	\overline{WE}	\overline{OE}	I/O ₁ - I/O ₉	I/O ₁₀ - I/O ₁₈
Standby	H	X	X	X	X	High-Z	High-Z
Refresh cycle	L	H	H	X	X	High-Z	High-Z
Byte read cycle	L	L	H	H	L	Data output	High-Z
	L	H	L	H	L	High-Z	Data output
Word read cycle	L	L	L	H	L	Data output	Data output
Byte write cycle	L	L	H	L	H	Data input	—
	L	H	L	L	H	—	Data input
Word write cycle	L	L	L	L	H	Data input	Data input
—	L	L	L	H	H	High-Z	High-Z

X = don't care.

7e

Absolute Maximum Ratings

Voltage on any pin relative to GND	
5-volt devices	-1.0 to +7.0 V
3.3-volt devices	-0.5 to +4.6 V
Operating temperature, T_{OPR}	0 to +70°C
Storage temperature, T_{STG}	-55 to +125°C
Short-circuit output current, I_{OS}	
5-volt devices	50 mA
3.3-volt devices	20 mA
Power dissipation, P_D	1.0 W

Exposure to Absolute Maximum Ratings for extended periods may affect device reliability; exceeding the ratings could cause permanent damage. The device should be operated within the limits specified under DC and AC Characteristics.

Capacitance $T_A = 25^\circ\text{C}; f = 1\text{ MHz}$

Parameter	Symbol	Max	Unit	Pins Under Test
Input capacitance	C_{I1}	5	pF	Addresses
	C_{I2}	7	pF	LCAS, UCAS, WE, OE, RAS
Input/output capacitance	C_O	7	pF	I/O ₁ - I/O ₁₆

Recommended Operating Conditions

Parameter	Symbol	5-Volt Devices			3.3-Volt Devices			Unit
		Min	Typ	Max	Min	Typ	Max	
Input voltage, high	V_{IH}	2.4		$V_{CC} + 1.0$	2.0		$V_{CC} + 0.3$	V
Input voltage, low	V_{IL}	-1.0		0.8	-0.5		0.8	V
Supply voltage	V_{CC}	4.5	5.0	5.5	3.0	3.3	3.6	V
Ambient temperature	T_A	0		+70	0		+70	°C

Self-Refresh Current $T_A = 0\text{ to }+70^\circ\text{C}; V_{CC} = +5\text{ V} \pm 10\% (42S4280A) \text{ or } +3.3\text{ V} \pm 0.3\text{ V} (42S4280L)$

Symbol	42S4280A	42S4280L	Conditions
I_{CC7}	300 μA max	100 μA max	I/O pins: $V_{IH} \geq V_{CC} - 0.2\text{ V}; V_{IL} \leq 0.2\text{ V}$ or open. Other input pins: $V_{IH} \geq V_{CC} - 0.2\text{ V}; V_{IL} \leq 0.2\text{ V}$ or open. $t_{RAS} \geq 100\ \mu\text{s}$

DC Characteristics; 5-Volt Devices $T_A = 0\text{ to }+70^\circ\text{C}; V_{CC} = +5.0\text{ V} \pm 10\%$

Parameter	Symbol	Min	Typ	Max	Unit	Test Conditions
Standby current	I_{CC2}			2.0	mA	$\overline{\text{RAS}} = \overline{\text{CAS}} \geq V_{IH}(\text{min}); I_O = 0\text{ mA}$
				300	μA	$\text{RAS} = \text{CAS} \geq V_{CC} - 0.2\text{ V}; I_O = 0\text{ mA}$
Input leakage current	$I_{I(L)}$	-10		10	μA	$V_{IN} = 0\text{ V to }V_{CC}$; all other pins not under test = 0 V
Output leakage current	$I_{O(L)}$	-10		10	μA	D_{OUT} disabled; $V_{OUT} = 0\text{ V to }V_{CC}$
Output voltage, low	V_{OL}			0.4	V	$I_{OL} = 4.2\text{ mA}$
Output voltage, high	V_{OH}	2.4			V	$I_{OH} = -5\text{ mA}$

DC Characteristics; 3.3-Volt Devices $T_A = 0$ to $+70^\circ\text{C}$; $V_{CC} = +3.3\text{ V} \pm 0.3\text{ V}$

Parameter	Symbol	Min	Typ	Max	Unit	Test Conditions
Standby current	I_{CC2}			500	μA	$\overline{\text{RAS}} = \overline{\text{CAS}} \geq V_{IH}(\text{min}); I_O = 0\text{ mA}$
				100	μA	$\overline{\text{RAS}} = \overline{\text{CAS}} \geq V_{CC} - 0.2\text{ V}; I_O = 0\text{ mA}$
Input leakage current	$I_{I(L)}$	-5		5	μA	$V_{IN} = 0\text{ V to } V_{CC}$; all other pins not under test = 0 V
Output leakage current	$I_{O(L)}$	-5		5	μA	D_{OUT} disabled; $V_{OUT} = 0\text{ V to } V_{CC}$
Output voltage, low	V_{OL}			0.4	V	$I_{OL} = 2.0\text{ mA}$
Output voltage, high	V_{OH}	2.4			V	$I_{OH} = -2.0\text{ mA}$

AC Characteristics $T_A = 0$ to $+70^\circ\text{C}$ μ PD424280A, 42S4280A: $V_{CC} = +5.0\text{ V} \pm 10\%$ μ PD424280L, 42S4280L: $V_{CC} = +3.3\text{ V} \pm 0.3\text{ V}$

Parameter	Symbol	-60		-70		-80		Unit	Test Conditions
		Min	Max	Min	Max	Min	Max		
Operating current, average	$I_{CC1} (+5)$		160		150		140	mA	$\overline{\text{RAS}}, \overline{\text{CAS}}$ cycling; $t_{RC} = t_{RC} \text{ min}$ (Note 5)
	$I_{CC1} (+3.3)$		150		140		130		
Operating current, $\overline{\text{RAS}}$ -only refresh cycle, average	$I_{CC3} (+5)$		160		150		140	mA	$\overline{\text{RAS}}$ cycling; $\overline{\text{CAS}} \geq V_{IH} \text{ min}$; $t_{RC} = t_{RC} \text{ min}$ (Note 5)
	$I_{CC3} (+3.3)$		150		140		130		
Operating current, fast-page cycle, average	$I_{CC4} (+5)$		110		100		90	mA	$\overline{\text{RAS}} \leq V_{IL}$; $\overline{\text{CAS}}$ cycling; $t_{PC} = t_{PC} \text{ min}$ (Note 5)
	$I_{CC4} (+3.3)$		110		100		90		
Operating current, $\overline{\text{CAS}}$ before $\overline{\text{RAS}}$ refresh cycle, average	$I_{CC5} (+5)$		160		150		140	mA	$\overline{\text{RAS}}$ cycling; $\overline{\text{CAS}} \leq V_{IL} \text{ max}$; $t_{RC} = t_{RC} \text{ min}$ (Note 5)
	$I_{CC5} (+3.3)$		160		150		140		
Access time from column address	t_{AA}		30		35		40	ns	(Notes 3, 4, 7, 8)
Access time from $\overline{\text{CAS}}$ precharge (rising edge)	t_{ACP}		35		40		45	ns	(Notes 3, 4, 7, 8, 16)
Column address setup time	t_{ASC}	0		0		0		ns	
Row address setup time	t_{ASR}	0		0		0		ns	
Column address to $\overline{\text{WE}}$ delay time	t_{AWD}	50		55		70		ns	(Note 14)
Access time from $\overline{\text{CAS}}$ (falling edge)	t_{CAC}		20		20		20	ns	(Notes 3, 4, 7, 8)
Column address hold time	t_{CAH}	15		15		15		ns	
$\overline{\text{CAS}}$ pulse width	t_{CAS}	20	10,000	20	10,000	20	10,000	ns	
$\overline{\text{CAS}}$ hold time for $\overline{\text{CAS}}$ before $\overline{\text{RAS}}$ refreshing	t_{CHR}	15		15		15		ns	(Note 15)
$\overline{\text{CAS}}$ hold time (CBR self-refresh mode)	t_{CHS}	-35		-40		-50		ns	For 42S4280A/L only

AC Characteristics (cont)

Parameter	Symbol	-60		-70		-80		Unit	Test Conditions
		Min	Max	Min	Max	Min	Max		
CAS to output in low-Z	t _{CLZ}	0		0		0		ns	(Notes 4, 7)
Fast-page $\overline{\text{CAS}}$ precharge time	t _{CP}	10		10		10		ns	
$\overline{\text{CAS}}$ precharge time	t _{CPN}	10		10		10		ns	
Fast-page $\overline{\text{CAS}}$ precharge to $\overline{\text{WE}}$ delay time	t _{CPWD}	55		60		75		ns	(Note 14)
CAS to $\overline{\text{RAS}}$ precharge time	t _{CRP}	10		10		10		ns	(Note 10)
$\overline{\text{CAS}}$ hold time	t _{CSH}	60		70		80		ns	
CAS setup time for CAS before RAS refresh cycle	t _{CSR}	5		5		5		ns	(Note 15)
CAS to $\overline{\text{WE}}$ delay	t _{CWD}	40		40		50		ns	(Note 14)
Write command referenced to $\overline{\text{CAS}}$ lead time	t _{CWL}	15		15		15		ns	
Data-in hold time	t _{DH}	15		15		15		ns	(Note 13)
Data-in setup time	t _{DS}	0		0		0		ns	(Note 13)
Masked write hold time referenced to $\overline{\text{RAS}}$	t _{MRH}	0		0		0		ns	
Access time from OE	t _{OEa}		20		20		20	ns	(Notes 3, 4, 7, 8)
OE data delay time	t _{OEaD}	15		15		15		ns	
OE command hold time	t _{OEh}	0		0		0		ns	
OE to RAS inactive setup time	t _{OEiS}	0		0		0		ns	
Output turnoff delay from OE	t _{OEZ}	0	15	0	15	0	15	ns	(Note 9)
Output disable from CAS high	t _{OFF}	0	15	0	15	0	20	ns	(Note 9)
OE to output in low-Z	t _{OLZ}	0		0		0		ns	(Notes 5, 7)
Fast-page read or write cycle time	t _{PC}	40		45		50		ns	(Note 6)
Fast-page read-modify-write cycle time with extended data output	t _{PRWC}	85		90		100		ns	(Note 6)
Access time from RAS	t _{RAC}		60		70		80	ns	(Notes 3, 4, 7, 8)

AC Characteristics (cont)

Parameter	Symbol	-60		-70		-80		Unit	Test Conditions
		Min	Max	Min	Max	Min	Max		
RAS to column address delay time	t _{RAD}	15	30	15	35	15	40	ns	(Note 8)
Row address hold time	t _{RAH}	10		10		10		ns	
Column address lead time referenced to RAS (rising edge)	t _{RAL}	30		35		40		ns	
RAS pulse width	t _{RAS}	60	10,000	70	10,000	80	10,000	ns	
Fast-page RAS pulse width	t _{RASP}	60	125,000	70	125,000	80	125,000	ns	
RAS pulse width (CBR self-refresh mode)	t _{RASS}	100		100		100		μs	For 42S4280A/L
Random read or write cycle time	t _{RC}	120		130		150		ns	(Note 6)
RAS to CAS delay time	t _{RCD}	20	40	20	50	20	60	ns	(Note 8)
Read command hold time referenced to CAS	t _{RCH}	0		0		0		ns	(Note 11)
Read command setup time	t _{RCS}	0		0		0		ns	
Refresh period	t _{REF}		8		8		8	ms	Addresses A ₀ - A ₈
RAS hold time referenced to CAS precharge	t _{RHCP}	35		40		45		ns	
RAS precharge time	t _{RP}	50		50		60		ns	
RAS precharge CAS hold time	t _{RPC}	0		0		0		ns	
RAS precharge time (CBR self-refresh mode)	t _{RPS}	120		130		150		ns	For 42S4280A/L
Read command hold time referenced to RAS	t _{RRH}	0		0		0		ns	(Note 11)
RAS hold time	t _{RSH}	20		20		25		ns	
Read-modify-write cycle time	t _{RWC}	165		175		200		ns	(Note 6)
RAS to WE delay	t _{RWD}	80		90		105		ns	(Note 14)
Write command referenced to RAS lead time	t _{RWL}	20		20		20		ns	
Rise and fall times	t _T	3	50	3	50	3	50	ns	(Note 4)
Write command hold time	t _{WCH}	15		15		15		ns	(Note 12)
Write command setup time	t _{WCS}	0		0		0		ns	(Note 14)

7e

AC Characteristics (cont)

Parameter	Symbol	-60		-70		-80		Unit	Test Conditions
		Min	Max	Min	Max	Min	Max		
Write command pulse width	t_{WP}	15		15		15		ns	(Note 12)

Notes:

- (1) All voltages are referenced to GND.
- (2) An initial pause of 100 μ s is required after power-up, followed by any eight RAS cycles, before proper device operation is achieved.
- (3) Ac measurements assume $t_T = 5$ ns.
- (4) V_{IH} (min) and V_{IL} (max) are reference levels for measuring the timing of input signals. Transition times are measured between V_{IH} and V_{IL} .
- (5) I_{CC1} , I_{CC3} , I_{CC4} , and I_{CC5} depend on output loading and cycle rates. Specified values are obtained with the output open. I_{CC3} is measured assuming that all column address inputs are held at either a high level or a low level during RAS-only refresh cycles. I_{CC4} is measured assuming that all column address inputs are switched only once during each fast-page cycle.
- (6) The minimum specifications are used only to indicate the cycle time at which proper operation over the full temperature range ($T_A = 0$ to $+70^\circ\text{C}$) is assured.
- (7) Load = 2 TTL (-1 mA, $+4$ mA) loads and 100 pF. For 3.3-volt devices, $V_{OH} = 2.0$ V and $V_{OL} = 0.8$ V (ac reference levels).
- (8) If $t_{RCD} \leq t_{RCD}(\text{max})$ and $t_{RAD} \leq t_{RAD}(\text{max})$, access time is defined by $t_{RAC}(\text{max})$.
If $t_{RCD} \geq t_{RCD}(\text{max})$, access time is defined by $t_{CAC}(\text{max})$.
If $t_{RAD} \geq t_{RAD}(\text{max})$, access time is defined by $t_{AA}(\text{max})$.
- (9) $t_{OFF}(\text{max})$ and $t_{OEZ}(\text{max})$ define the time at which the outputs become open-circuit and are not referenced to V_{OH} or V_{OL} .
- (10) The t_{CRP} requirement should be applicable for $\overline{\text{RAS}}$ / $\overline{\text{CAS}}$ cycles preceded by any cycle.
- (11) Either t_{RRH} or t_{RCH} must be satisfied for a read cycle.
- (12) Parameter t_{WP} is applicable for a delayed write cycle such as a read-write/read-modify-write cycle. For early write cycles, both t_{WCS} and t_{WCH} must be met.
- (13) These parameters are referenced to the falling edge of one of the $\overline{\text{CAS}}$ signals for early write cycles and to the falling edge of $\overline{\text{WE}}$ for delayed write or read-modify-write cycles.
- (14) t_{WCS} , t_{RWD} , t_{CWD} , t_{CPWD} and t_{AWD} are restrictive operating parameters in read-write/read-modify-write cycles only. If $t_{WCS} \geq t_{WCS}(\text{min})$, the cycle is an early write cycle and the data I/O pins will remain open-circuit throughout the entire cycle. If $t_{CWD} \geq t_{CWD}(\text{min})$, $t_{RWD} \geq t_{RWD}(\text{min})$, and $t_{AWD} \geq t_{AWD}(\text{min})$, then the cycle is a read-write cycle and the data I/O pins will contain data read from the selected cells. If neither of the above conditions is met, the condition of the data I/O pins (at access time and until $\overline{\text{CAS}}$ returns to V_{IH}) is indeterminate.
- (15) Holding $\overline{\text{LCAS}}$ or $\overline{\text{UCAS}}$ low prior to $\overline{\text{RAS}}$ going negative will initiate a CAS before RAS refresh cycle (t_{CSR} and t_{CHR} must be satisfied).
- (16) The first $\overline{\text{CAS}}$ falling edge is used as a reference for the start of t_{ACP} (CAS precharge access time).

Timing Waveforms

Word Read Cycle

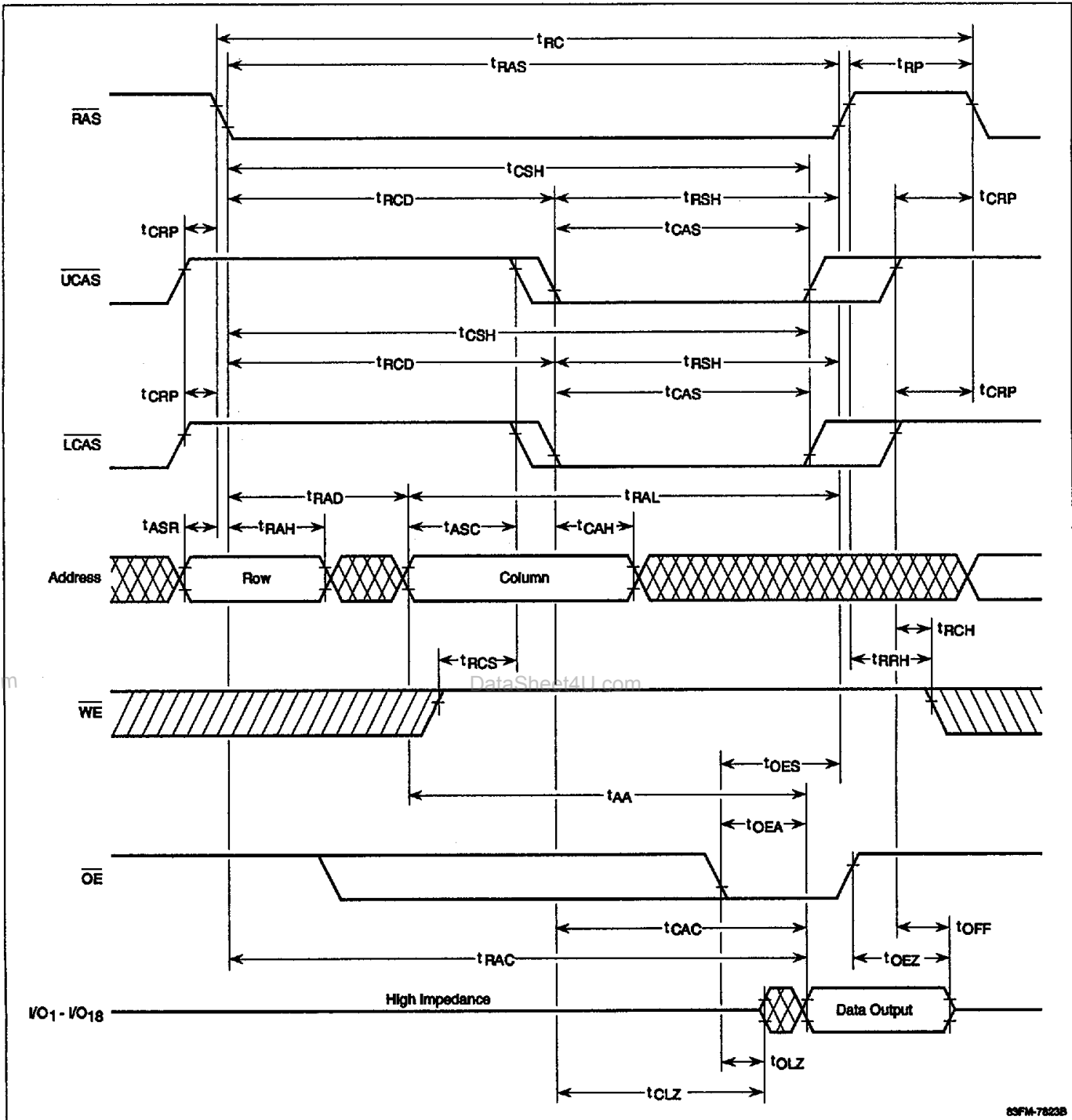

7e

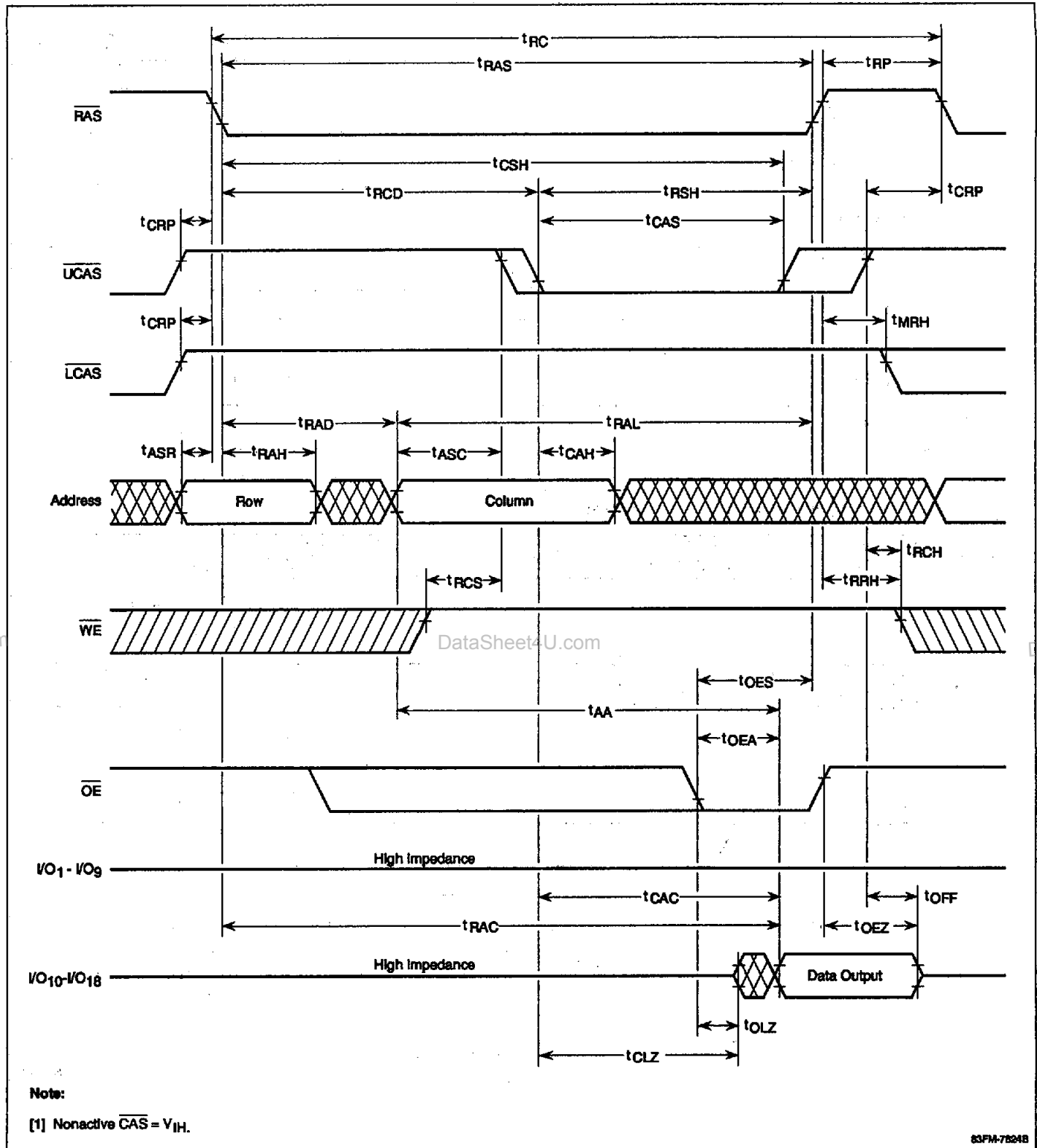
Timing Waveforms (cont)**Byte Read Cycle**

Timing Waveforms (cont)

Word Early-Write Cycle

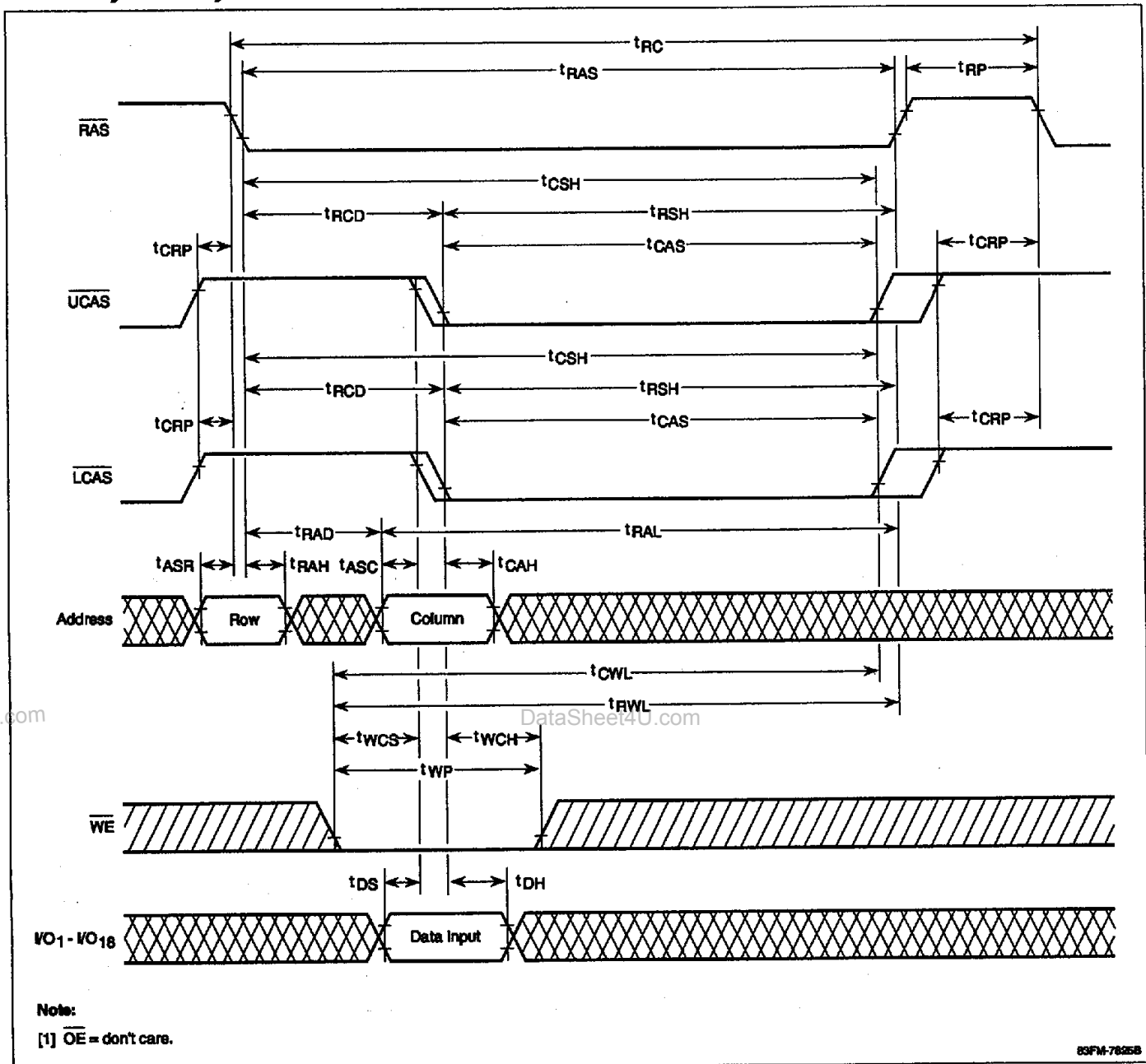

DataSheet4U.com

7e

Timing Waveforms (cont)

Byte Early-Write Cycle

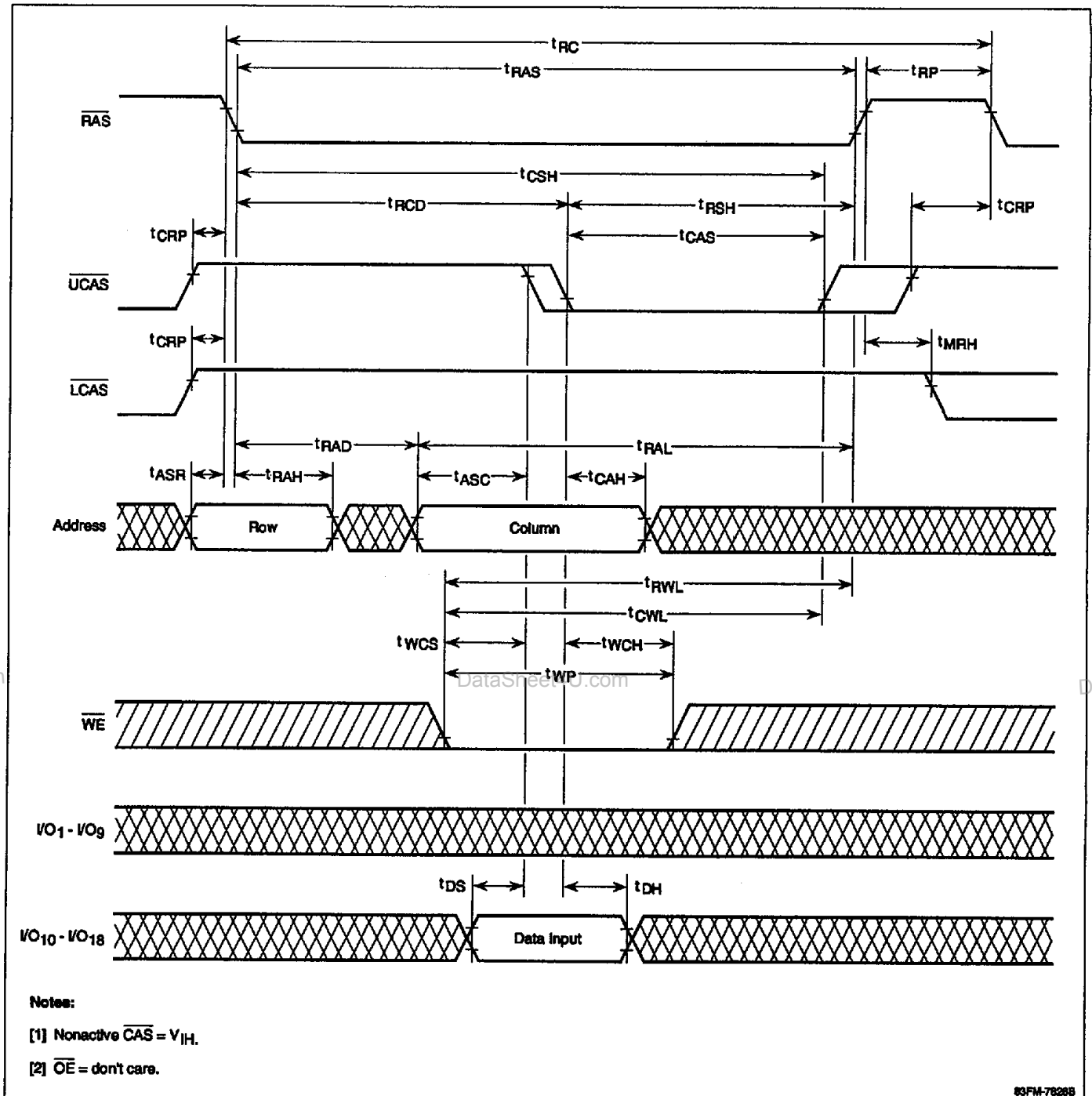

Timing Waveforms (cont)

Word Late-Write Cycle

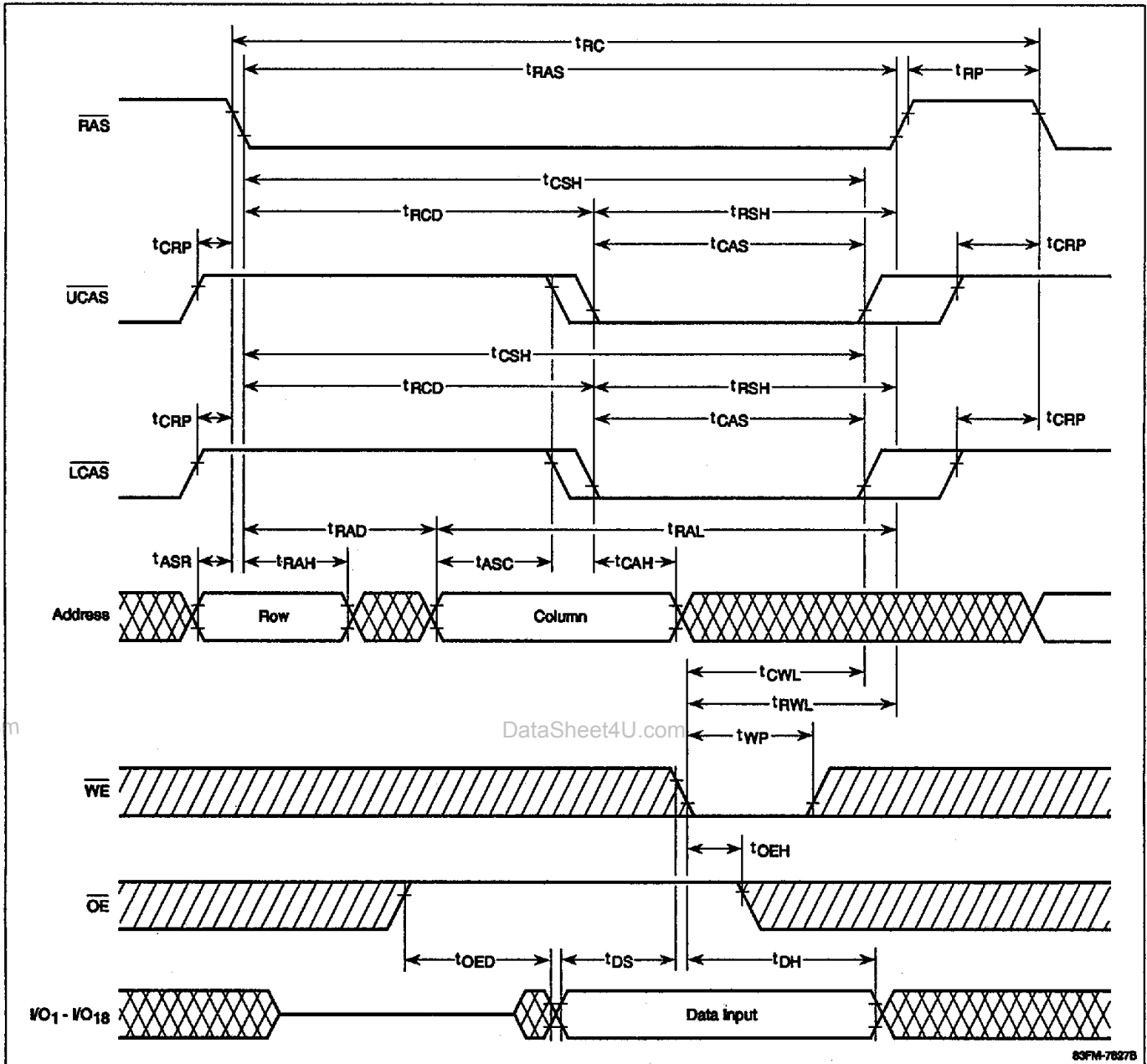

7e

Timing Waveforms (cont)

Byte Late-Write Cycle

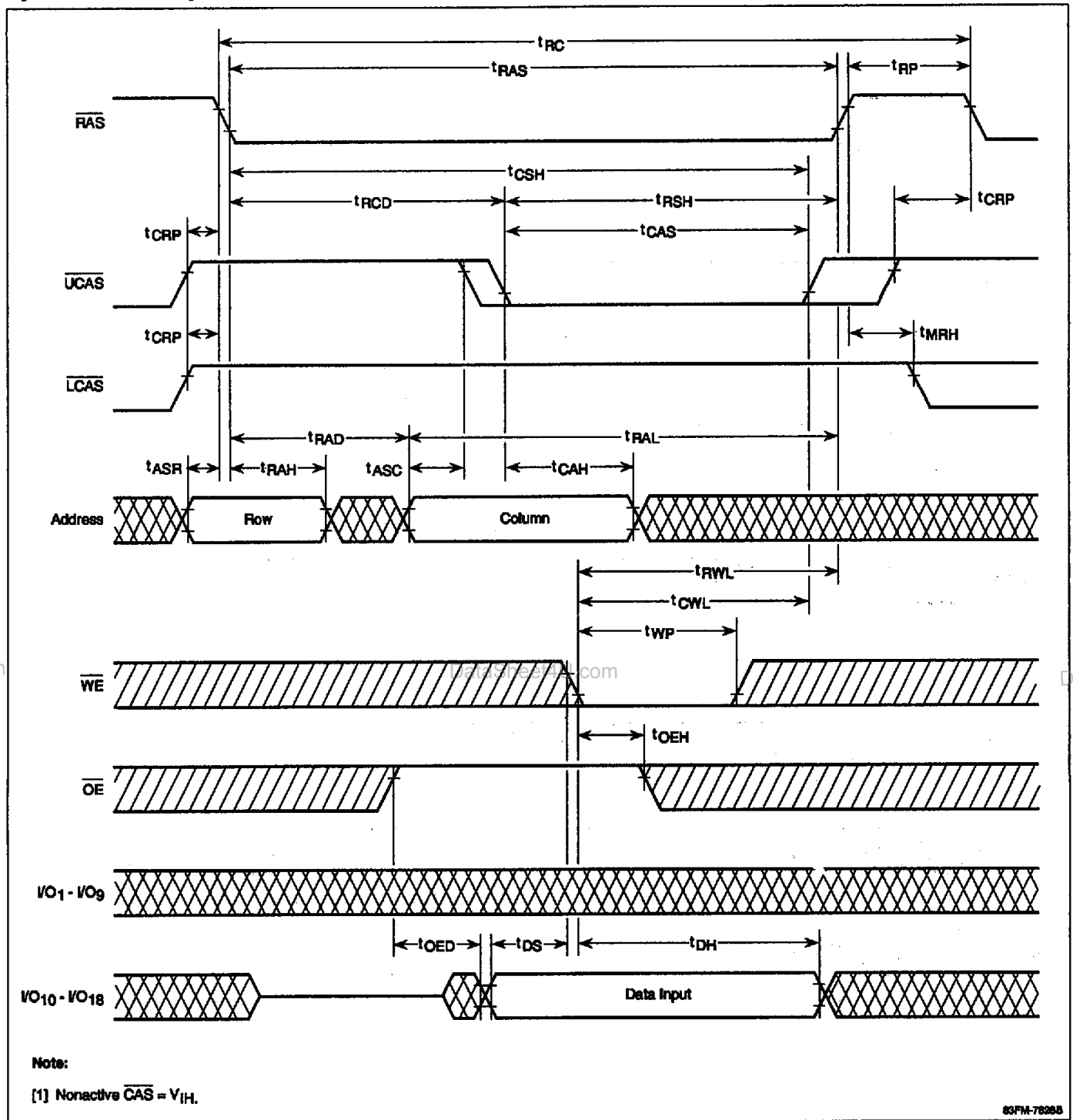

Timing Waveforms (cont)

Word Read-Modify-Write Cycle

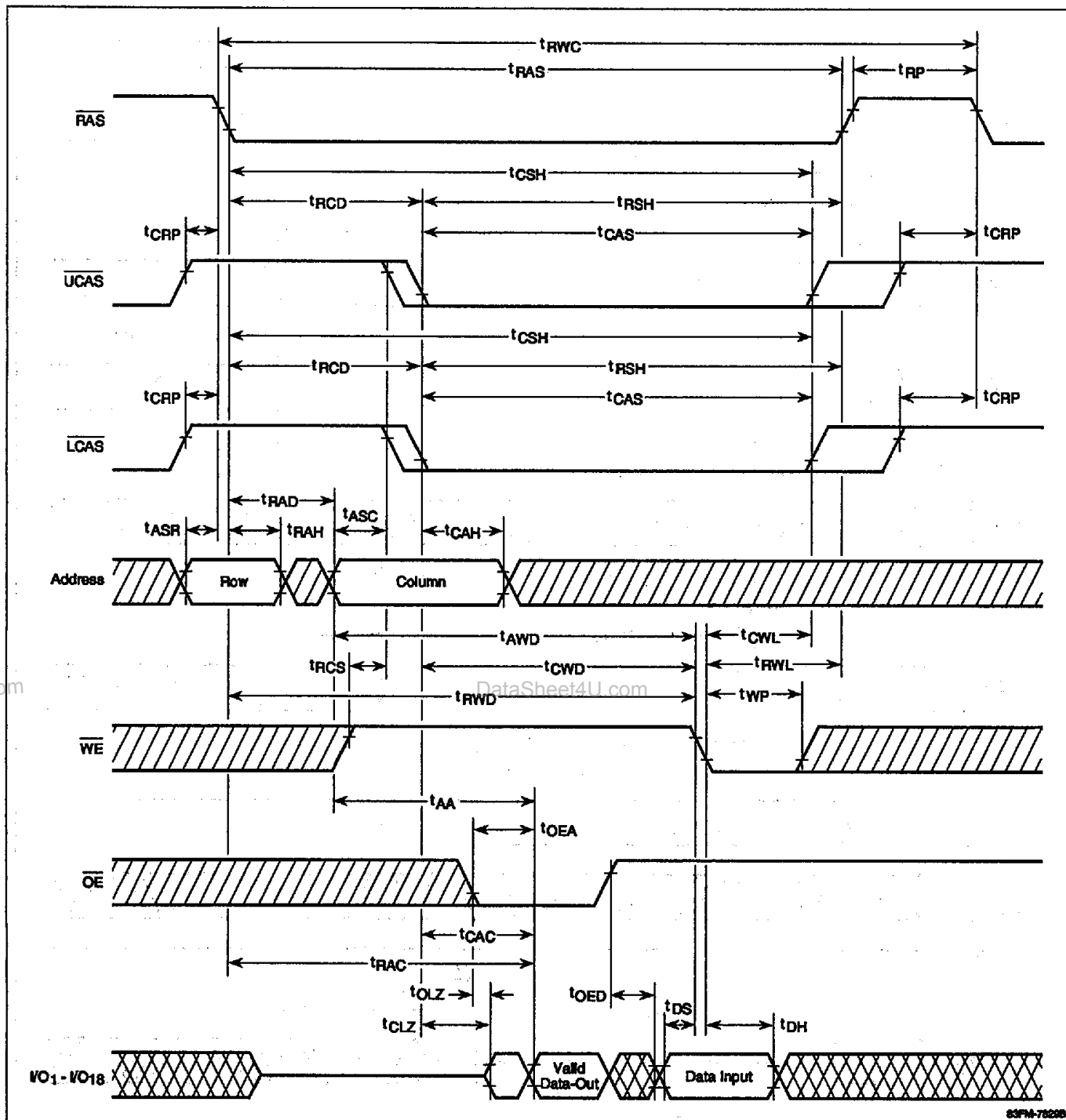

DataSheet4U.com

7e

Timing Waveforms (cont)

Byte Read-Modify-Write Cycle

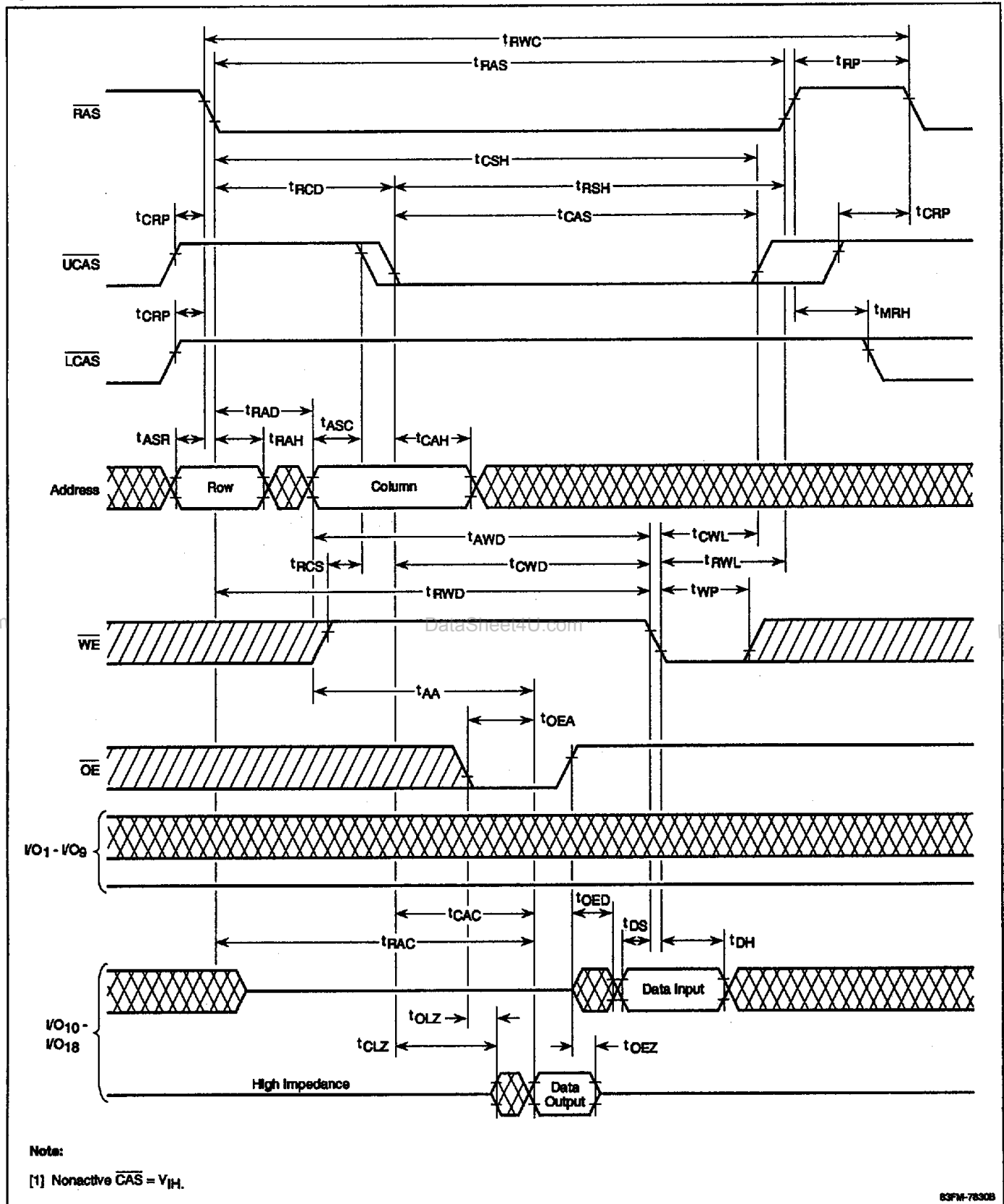

Timing Waveforms (cont)

Word Fast-Page Read Cycle

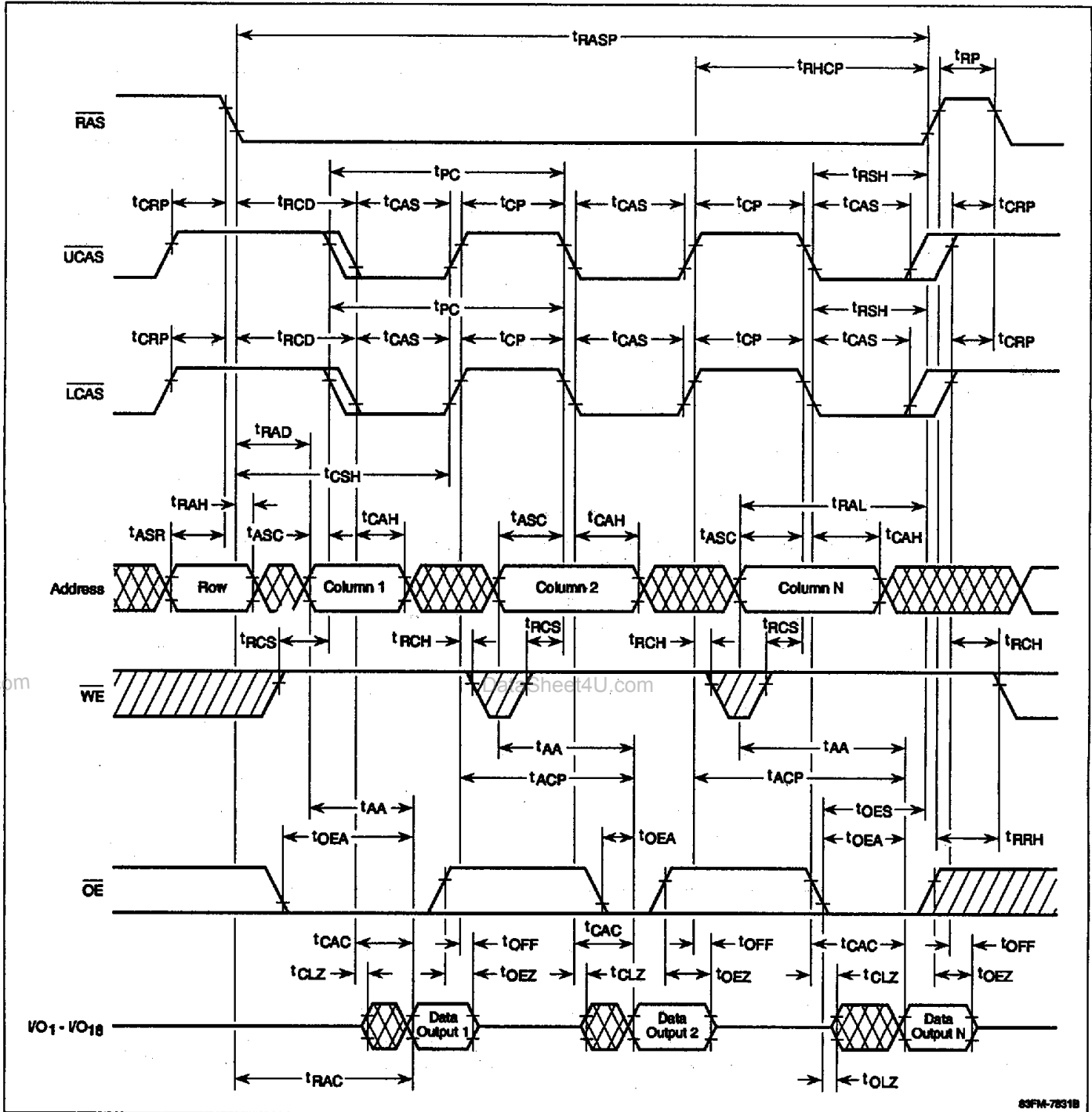

7e

Timing Waveforms (cont)

Byte Fast-Page Read Cycle

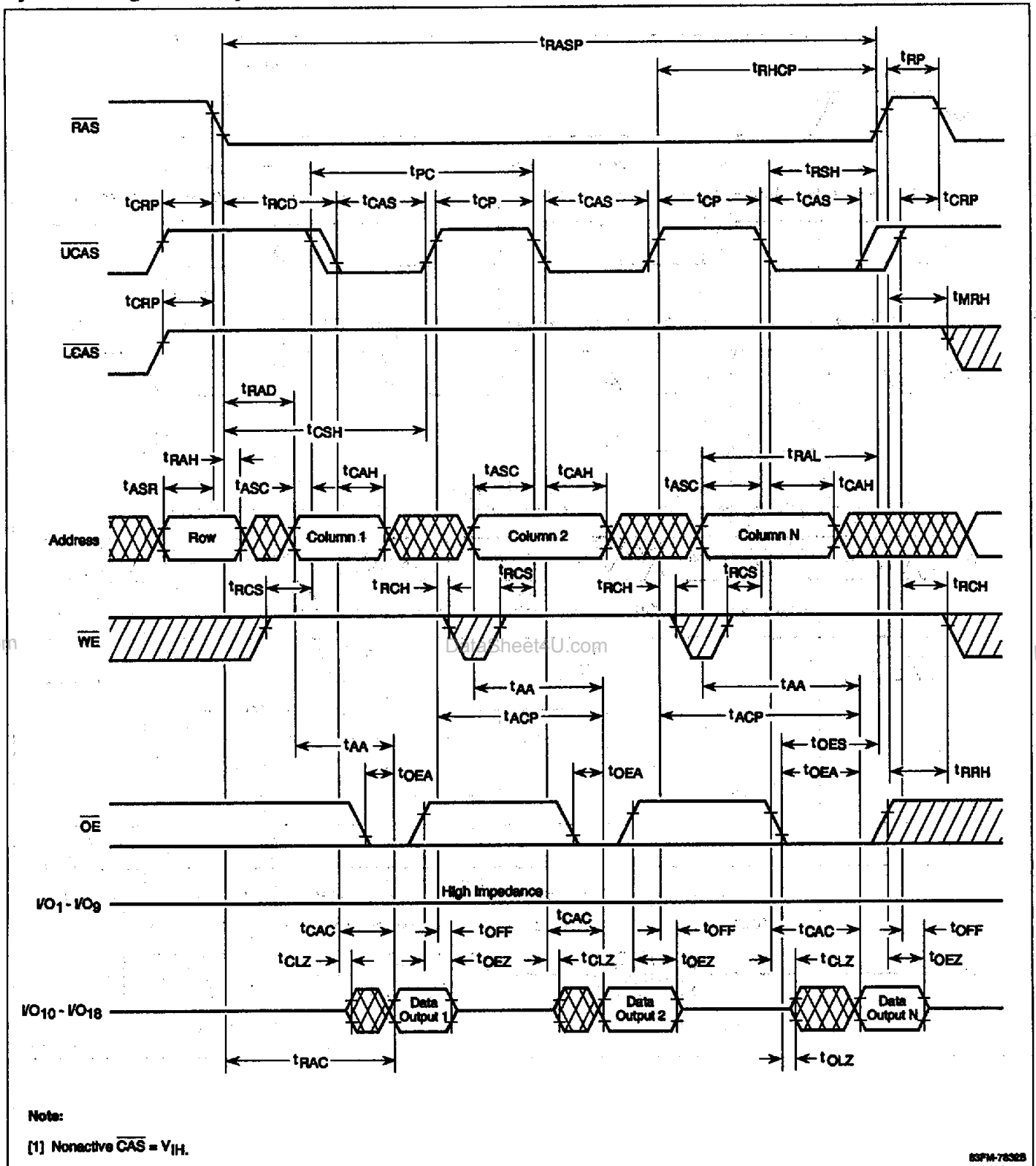

Timing Waveforms (cont)

Word Fast-Page Early-Write Cycle

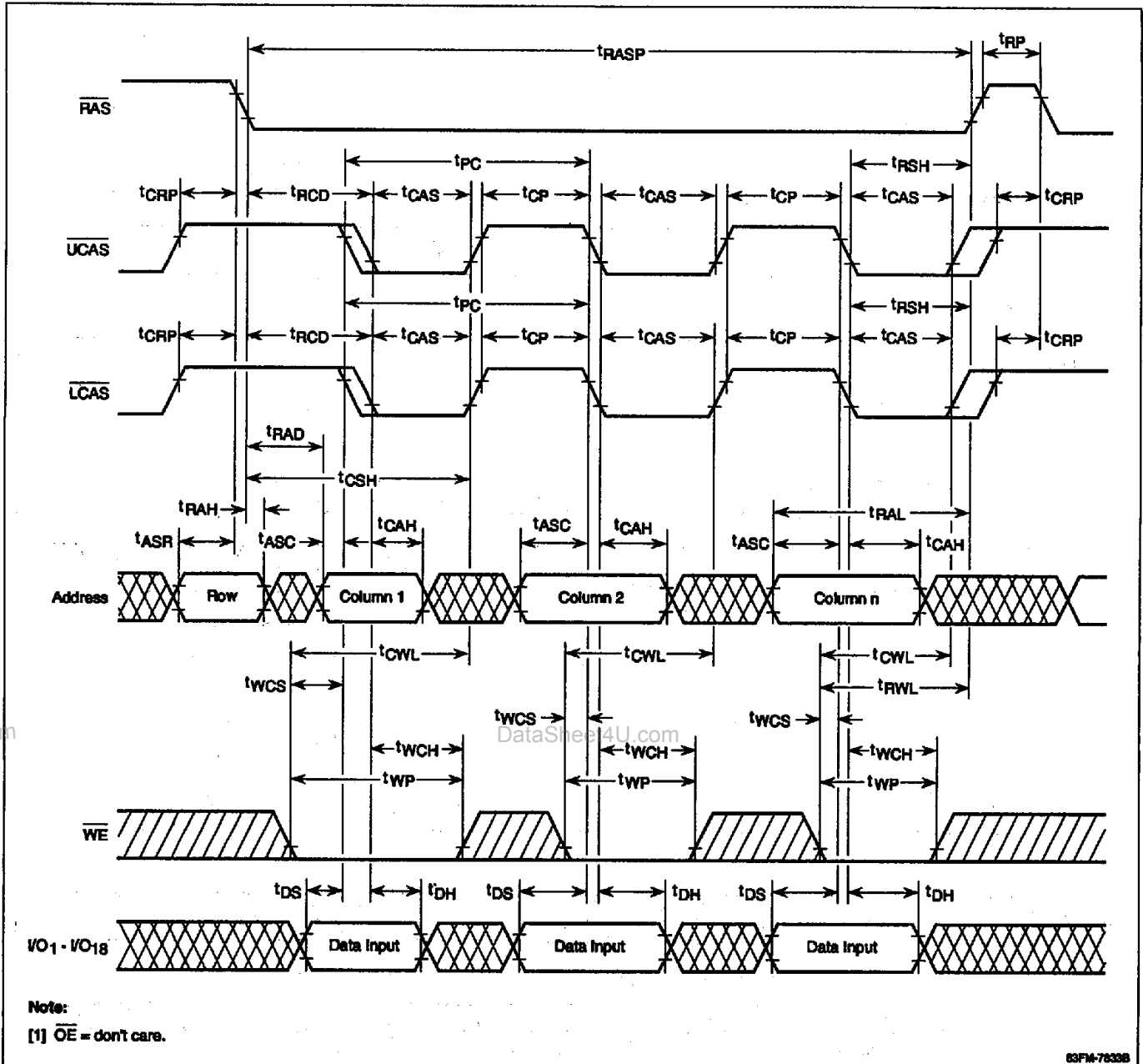

Timing Waveforms (cont)

Byte Fast-Page Early-Write Cycle

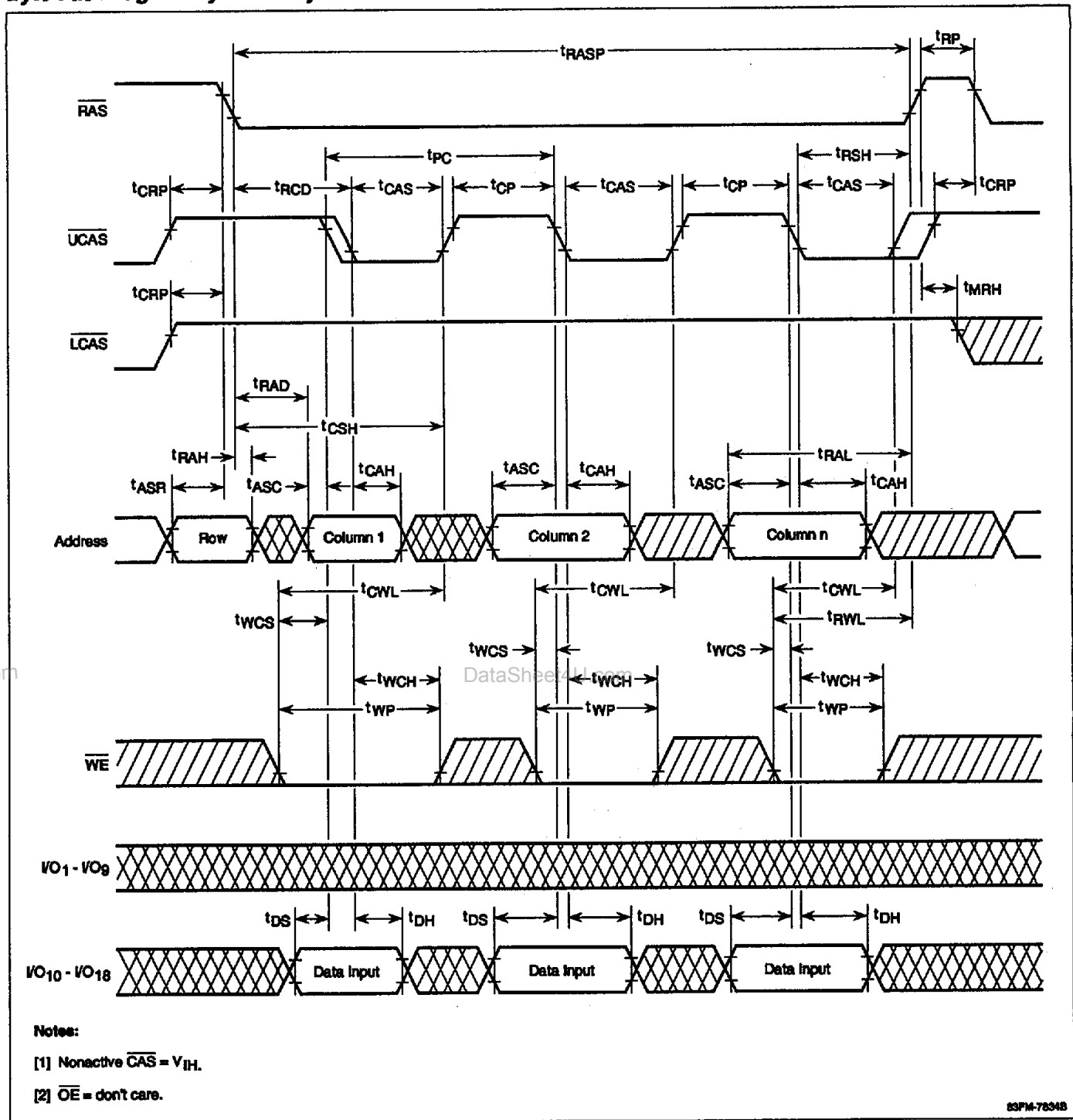

Timing Waveforms (cont)

Byte Fast-Page Late-Write Cycle

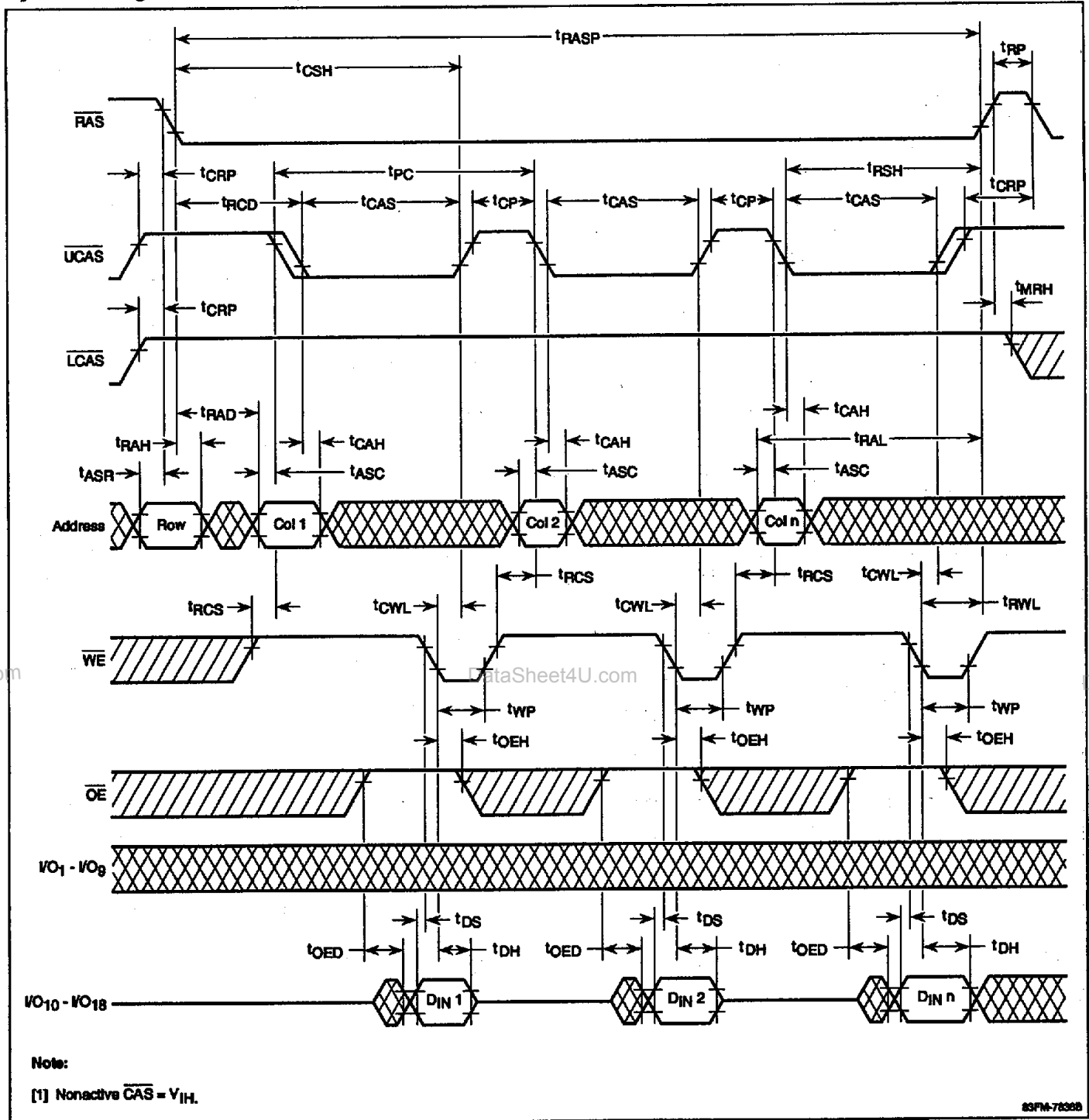

Timing Waveforms (cont)

Word Fast-Page Read-Modify-Write Cycle

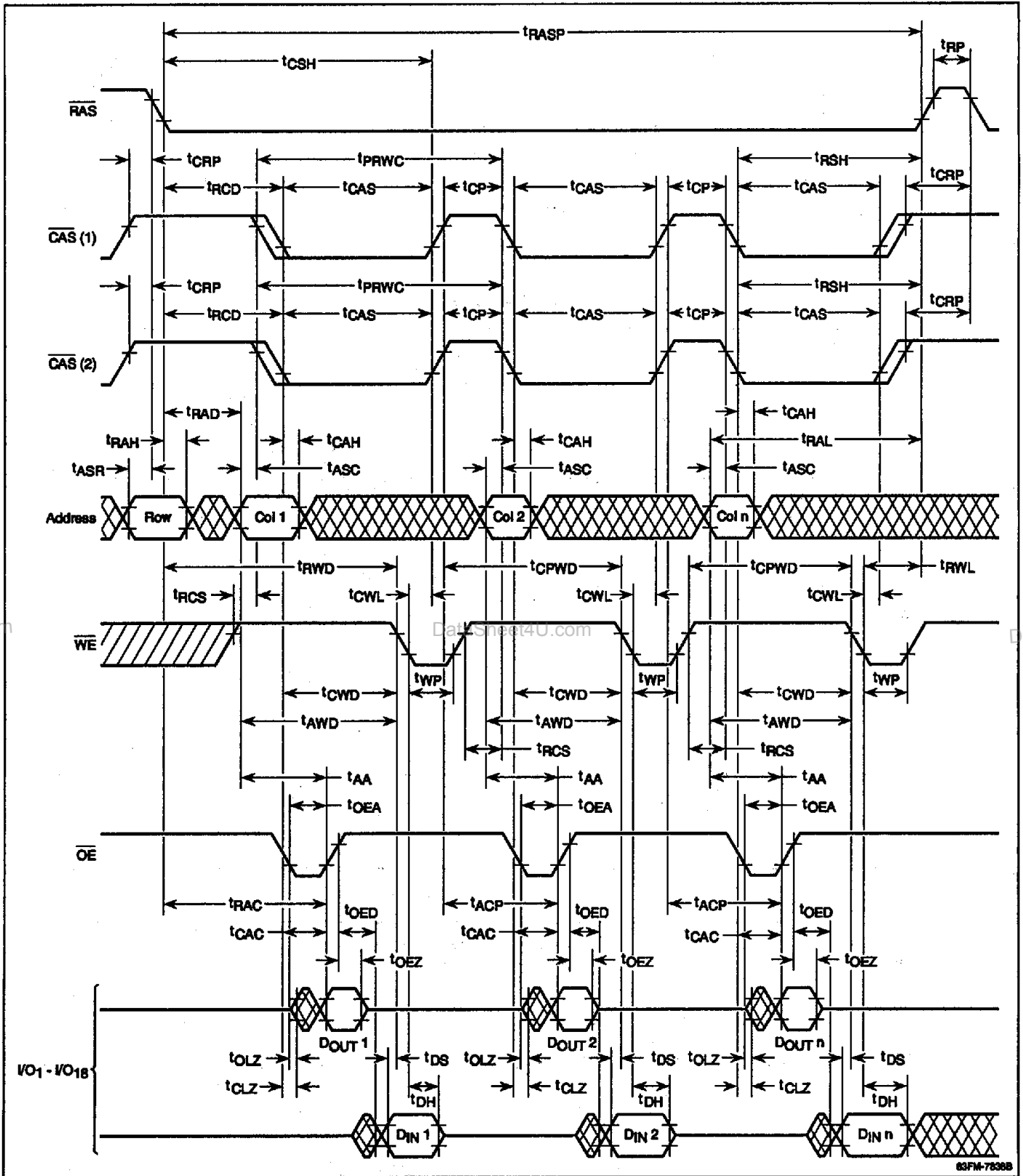

Timing Waveforms (cont)

Hidden-Refresh Cycle (Word Read Cycle)

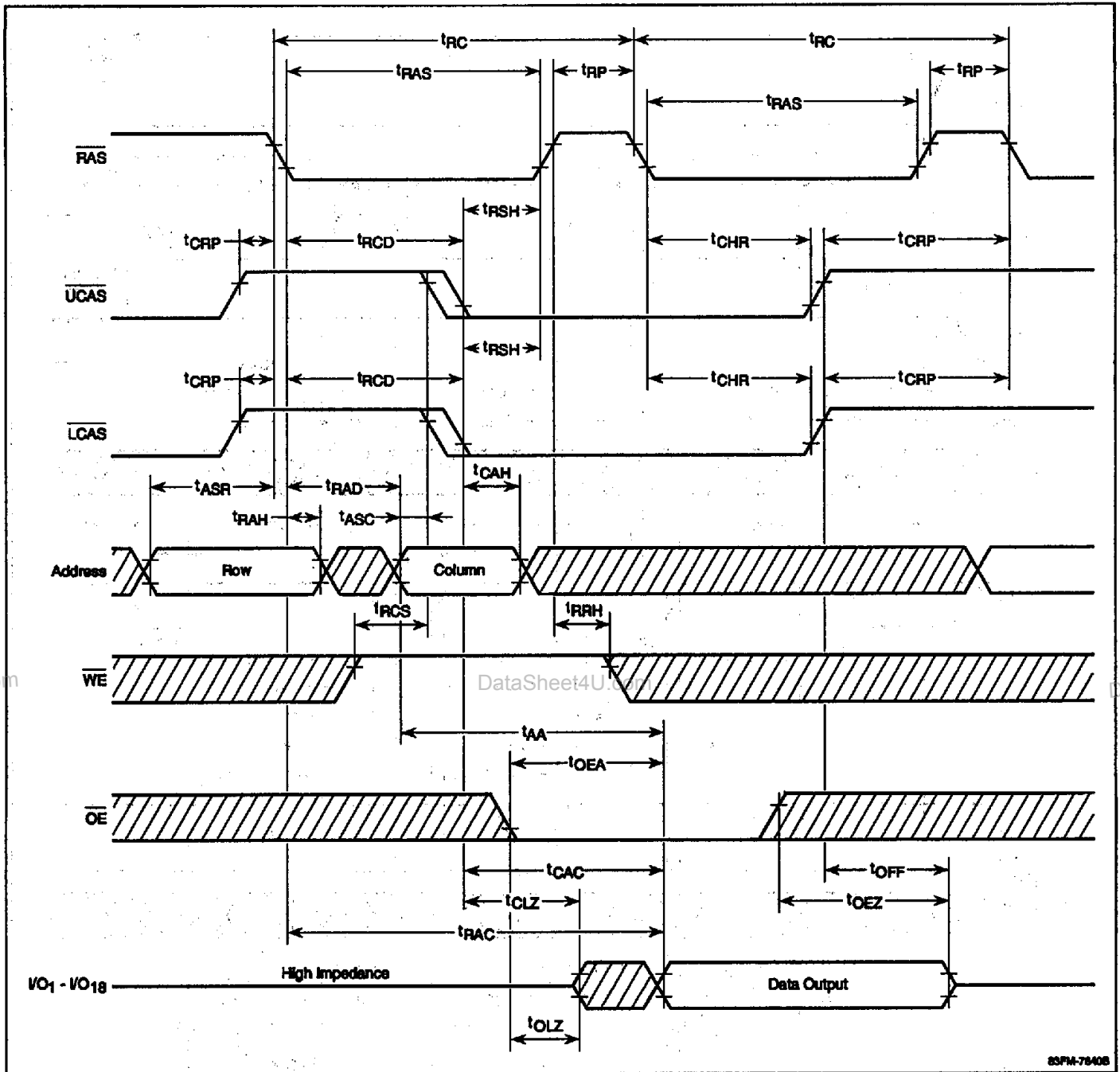

83F14-7840B

Timing Waveforms (cont)

Hidden-Refresh Cycle (Word Write Cycle)

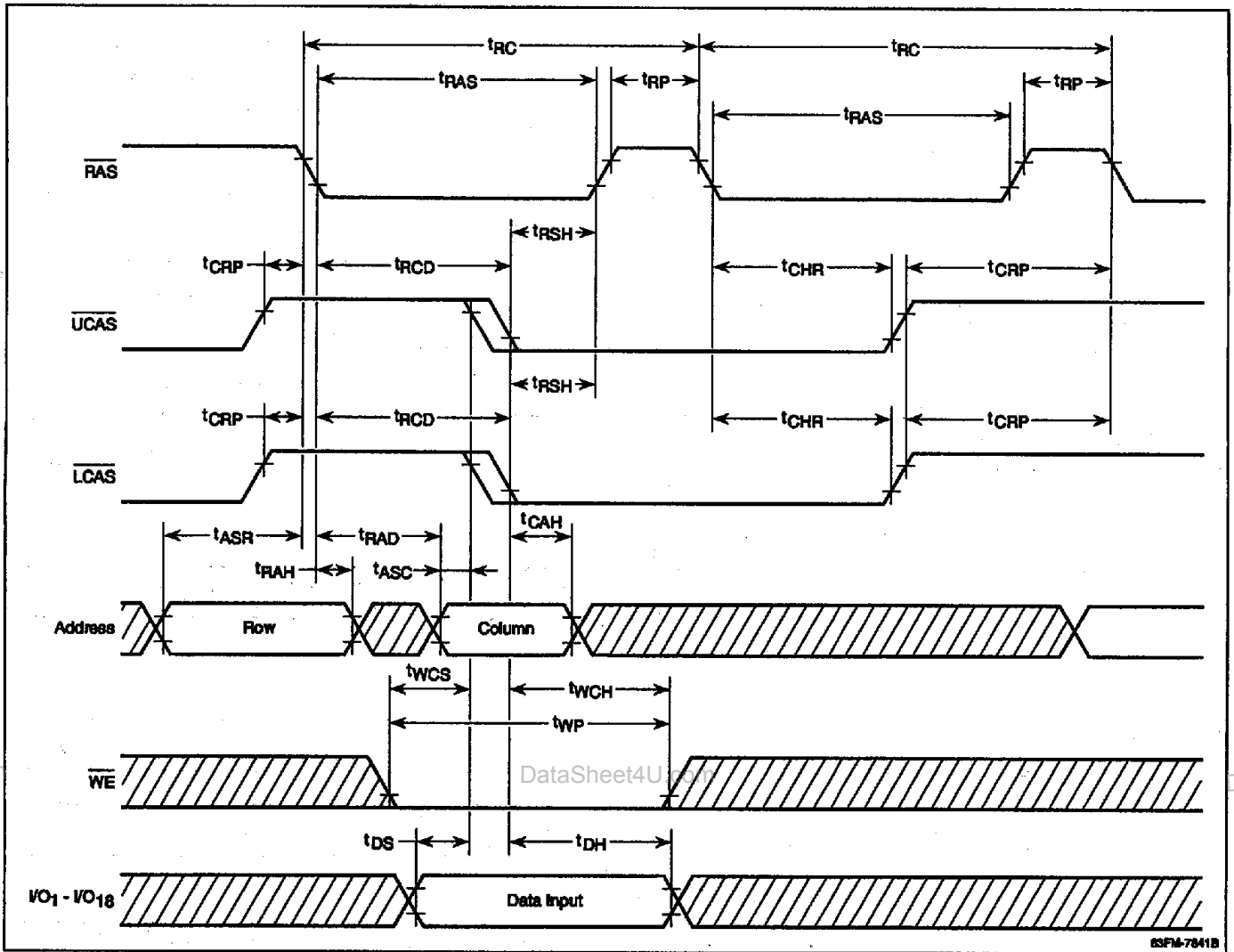

63FM-7841B

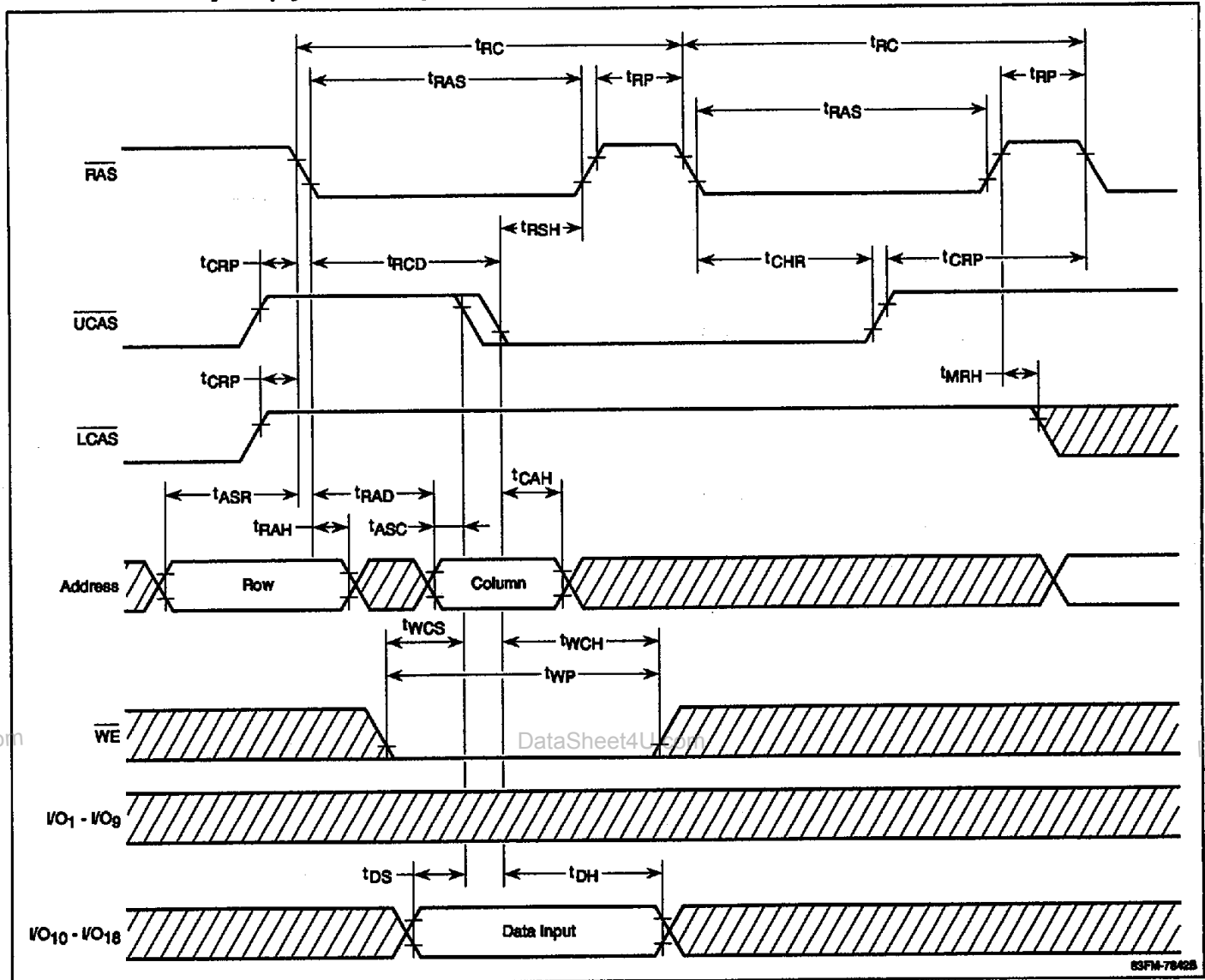
Timing Waveforms (cont)**Hidden-Refresh Cycle (Byte Write Cycle)**

Timing Waveforms (cont)

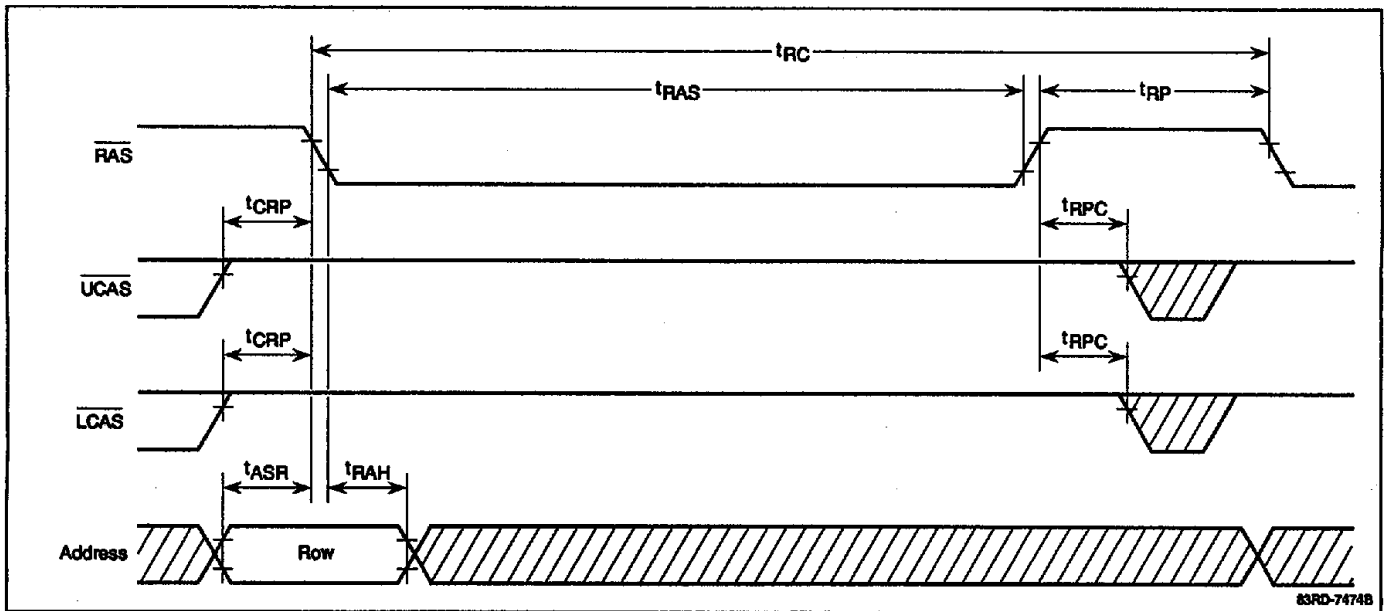
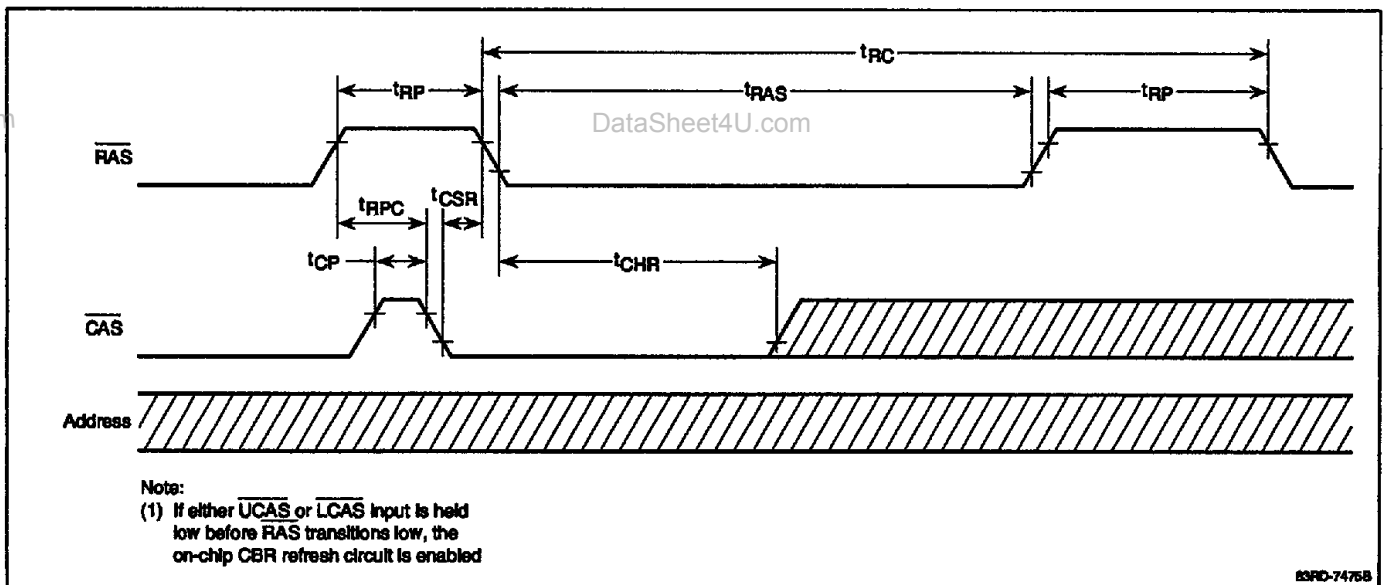
RAS-Only Refresh Cycle**CAS Before RAS Refresh Cycle**

Timing Waveforms (cont)

CBR Self-Refresh Cycle

