

RS-232 LINE DRIVER/RECEIVER

The μ PD4711B is a high-voltage silicon gate CMOS line driver/reciever conforming to the EIA/TIA-232-E standard. It can operate with a single +5 V power source because it is provided with a DC-DC converter. In addition, this line driver/receiver has many ancillary functions, including output control, threshold select, and standby functions. Because the μ PD4711B is provided with two output driver circuits and two receiver circuits, it can constitute an RS-232 interface circuit with a single chip.

FEATURES

- Conforms to EIA/TIA-232-E (RS-232C) standard
- +5 V single power source
- Threshold select pin selecting two types of threshold voltages
- Standby mode can be set by making standby pin high to reduce circuit current.
- Three-state output configuration. Both driver and receiver outputs go into high-impedance state in standby mode.

ORDERING INFORMATION

Part Number	Package
μ PD4711BCX	20-pin plastic DIP (300 mil)
μ PD4711BGS	20-pin plastic SOP (300 mil)

The information in this document is subject to change without notice.

BLOCK DIAGRAM/PIN CONFIGURATION (Top View)

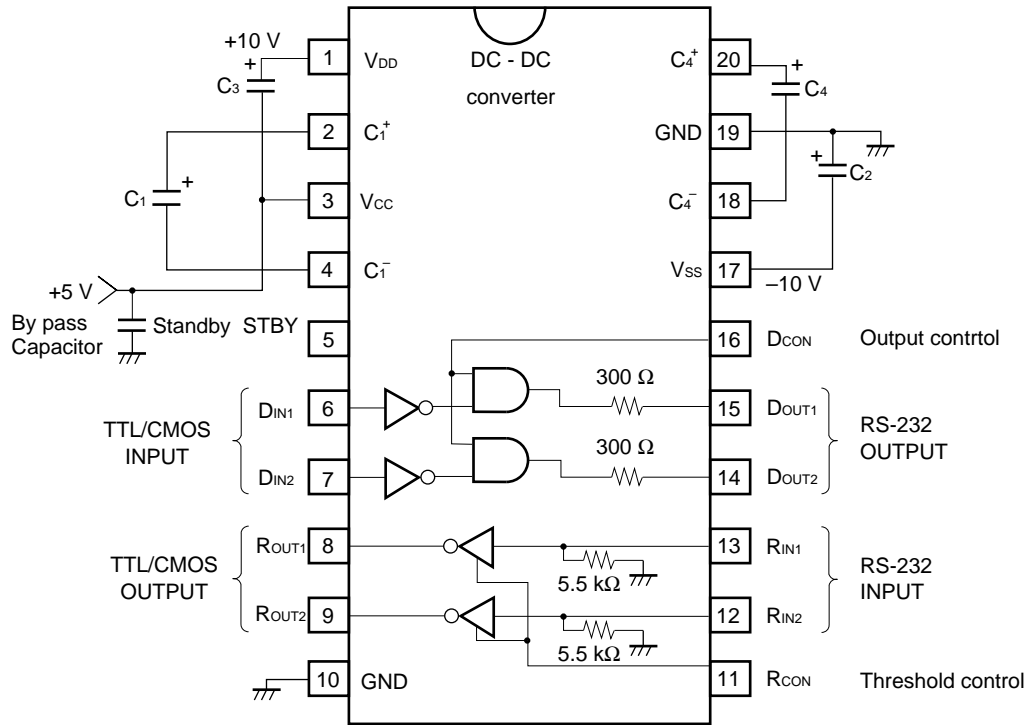

- * V_{DD} and V_{SS} are output pins of voltages internally boosted. Connecting a load directly to these pins is not recommended.
- ** The standby pin is internally pulled down.
- *** Use capacitors with a working voltage of 16 V or higher as C₁ through C₄. Insert a bypass capacitor about 0.1 to 1 μF between V_{CC} pin to GND pin.

TRUTH TABLE

Drivers

STBY	D _{CON}	D _{IN}	D _{OUT}	Remark
H	X	X	Z	Standby mode (DC-DC converter stops)
L	L	X	L	Mark level output
L	H	L	H	Space level output
L	H	H	L	Mark level output

Receivers

STBY	R _{IN}	R _{OUT}	Remark
H	X	Z	Stanby mode (DC-DC converter stops)
L	L	H	Mark level input
L	H	L	Space level input

Receiver input threshold voltage

R _{CON}	R _{IN1} to R _{IN2}
L	A mode
H	B mode

H: high level, L: low level, Z: high impedance, X: H or L

ABSOLUTE MAXIMUM RATINGS (T_A = 25 °C)

Parameter	Symbol	Ratings	Unit
Supply voltage	V _{CC}	-0.5 to +6.0	V
Driver input voltage	D _{IN}	-0.5 to V _{CC} +0.5	V
Receiver input voltage	R _{IN}	-30.0 to +30.0	V
Driver output voltage	D _{OUT}	-25.0 to +25.0 ^{Note 1}	V
Receiver output voltage	R _{OUT}	-0.5 to V _{CC} + 0.5	V
Receiver input current	I _{IN}	±60.0	mA
Operating temperature range	T _A	-40 to +85	°C
Storage temperature range	T _{stg}	-55 to +150	°C
Power dissipation	P _T	0.5	W

Note 1. Pulse width: 1 ms, duty factor: 10 % MAX.

RECOMMENDED OPERATING RANGE

Parameter	Symbol	MIN.	TYP.	MAX.	Unit
Supply voltage	V _{CC}	4.5	5.0	5.5	V
Receiver input voltage	R _{IN}	-30		+30	V
Operating temperature range	T _A	-20		80	°C
External capacitance	Note 2	1.0	22	47	μF

Note 2. The capacitance of an electrolytic capacitor decreases at a low temperature (0 °C or lower). Determine the capacitance of the capacitor to be used taking this into consideration when the μPD4711B is used at a low temperature. Keep the wiring length between the capacitor and IC as short as possible.

ELECTRICAL CHARACTERISTICS (OVERALL)

(Unless otherwise specified, V_{CC} = +5 V ±10 %, T_A = -20 °C to +80 °C, C₁ to C₄ = 22 μF)

Parameter	Symbol	Conditions	MIN.	TYP.	MAX.	Unit
Circuit current	I _{CC1}	V _{CC} = +5 V, no load, R _{IN} pin open (Standby pin open)		4.5	9.0	mA
Circuit current	I _{CC2}	V _{CC} = +5 V, R _L = 3 kΩ (D _{OUT}), D _{IN} = GND, R _{IN} and R _{OUT} pins open (Standby pin open)		15.0	25.0	mA
Standby circuit current	I _{CC} (Standby)	V _{CC} = +5 V, no load, R _{IN} pin open (Standby pin high)		50	120	μA
Standby low-level input voltage	V _{IL} (Standby)	Note 3			0.8	V
Standby high-level input voltage	V _{IH} (Standby)		2.0			V
Input capacitance	C _{IN}	Driver input and receiver input V _{CC} = +5 V, vs. GND, f = 1 MHz			10	pF

* TYP.: Typical (reference) value at T_A = 25 °C.

Note 3. Because the standby pin is internally pulled down, if the standby pin is left open, operating mode is in effect.

ELECTRICAL CHARACTERISTICS (DRIVER)

(Unless otherwise specified, $V_{CC} = +5\text{ V} \pm 10\%$, $T_A = -20\text{ }^\circ\text{C}$ to $+80\text{ }^\circ\text{C}$, C_1 to $C_4 = 22\text{ }\mu\text{F}$)

Parameter	Symbol	Conditions	MIN.	TYP.	MAX.	Unit
Low-level input voltage	V_{IL}				0.8	V
High-level input voltage	V_{IH}		2.0			V
Low-level input current	I_{IL}		0		-1.0	μA
High-level input current	I_{IH}		0		1.0	μA
Output voltage	V_{DO}	$V_{CC} = +5.0\text{ V}$, $R_L = \infty$, $T_A = 25\text{ }^\circ\text{C}$		± 9.7		V
		$V_{CC} = +5.0\text{ V}$, $R_L = 3\text{ k}\Omega$	± 5.5			V
		$V_{CC} = +4.5\text{ V}$, $R_L = 3\text{ k}\Omega$	± 5.0			V
Output short current	I_{SC}	$V_{CC} = +5.0\text{ V}$, vs. GND		± 15	± 40	mA
Slew rate	SR	$C_L = 10\text{ pF}$, $R_L = 3\text{ to }7\text{ k}\Omega$	1.5	11	30	V/ μs
		$C_L = 2500\text{ pF}$, $R_L = 3\text{ to }7\text{ k}\Omega$	1.5	6	30	V/ μs
Propagation delay time ^{Note 4}	t_{PHL}	$R_L = 3.5\text{ k}\Omega$, $C_L = 2500\text{ pF}$		0.8		μs
	t_{PLH}					
Output resistance	R_O	$V_{CC} = V_{DD} = V_{SS} = 0\text{ V}$ $V_{OUT} = \pm 2\text{ V}$	300			Ω
Standby output transition time	t_{DAZ}	Note 5		4	10	μs
Standby output transition time	t_{DZA}	Note 5		25	50	ms

* TYP.: Typical (reference) value at $T_A = 25\text{ }^\circ\text{C}$.

Note 4. Test point

If the output control pin is made low, the driver output goes low regardless of the driver input state.

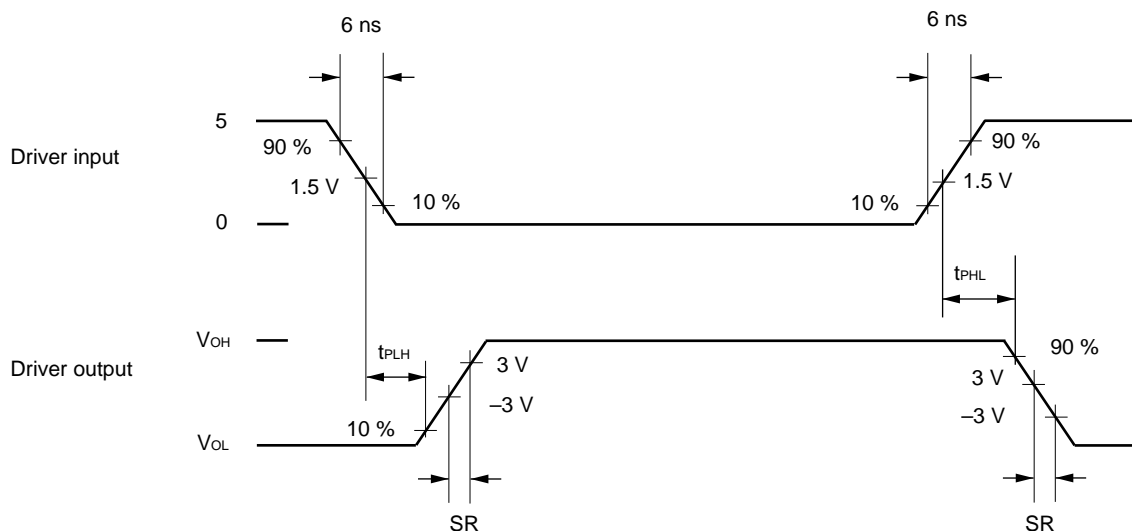

Note 5. Test Point

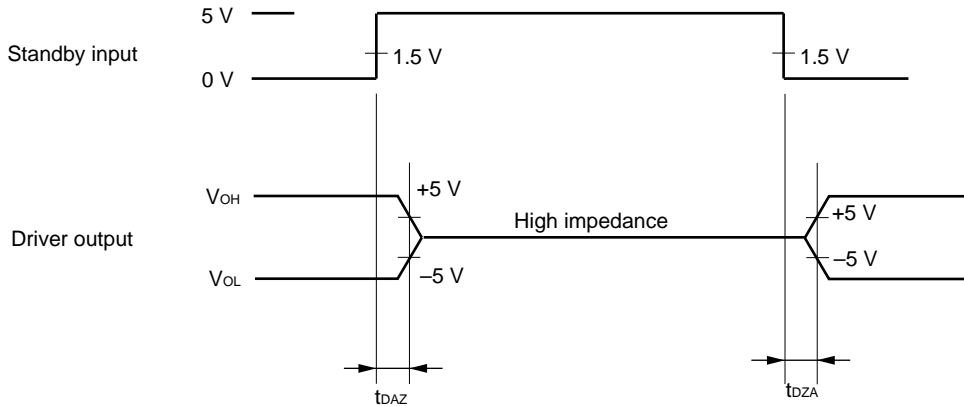

Do not perform communication within the standby output transition time t_{DZA} on power application or on releasing the standby mode.

ELECTRICAL CHARACTERISTICS (RECEIVER)

(Unless otherwise specified, V_{CC} = +5 V ± 10 %, T_A = -20 °C to +80 °C, C₁ to C₄ = 22 μF)

Parameter	Symbol	Conditions	MIN.	TYP.	MAX.	Unit
Low-level output voltage	V _{OL}	I _{OUT} = 4 mA			0.4	V
High-level output voltage	V _{OH}	I _{OUT} = -4 mA	V _{CC} -0.8			V
Low-level input voltage	V _{IL}	R _{CON} pin			0.8	V
High-level input voltage	V _{IH}	R _{CON} pin	2.0			V
Propagation delay time ^{Note 6}	t _{PHL} t _{PLH}	R _L = 1 kΩ, C _L = 150 pF		0.13		μs
Input current	I _{IN}	V _{IN} = ±5 V		1		mA
Input resistance	R _i	V _{IN} = ±3 to ±25	3	5	7	kΩ
Input pin release voltage	V _{IO}	Input threshold A mode only			0.5	V
Input threshold A mode (R _{CON} pin low)	V _{IH}	V _{CC} = +5 V	1.6	2.2	2.6	V
	V _{IL}	V _{CC} = +5 V	0.6	1	1.6	V
	V _H	V _{CC} = +5 V (hysteresis width)	0.5	1.2	1.8	V
Input threshold B mode (R _{CON} pin high)	V _{IH}	V _{CC} = +5 V	1.6	2.2	2.6	V
	V _{IL}	V _{CC} = +5 V	-0.4	-1.8	-3.0	V
	V _H	V _{CC} = +5 V (hysteresis width)	2.6	4.0	5.4	V
Standby output transition time	t _{DAZ}	Note 7		0.4	1	μs
Standby output transition time	t _{DZA}	Note 7		0.03	10	ms

* TYP.: Typical (reference) value at T_A = 25 °C.

Note 6. Test Point

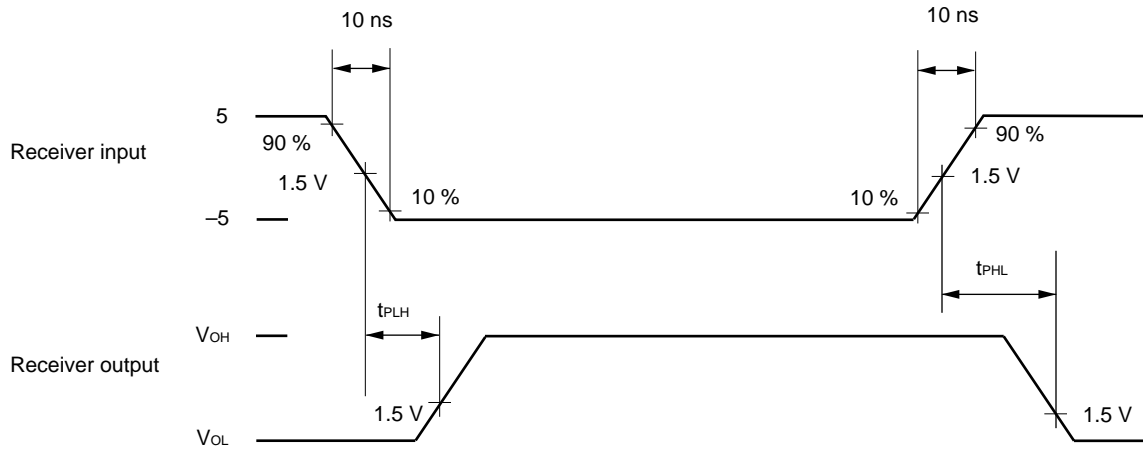

Note 7. Test Point

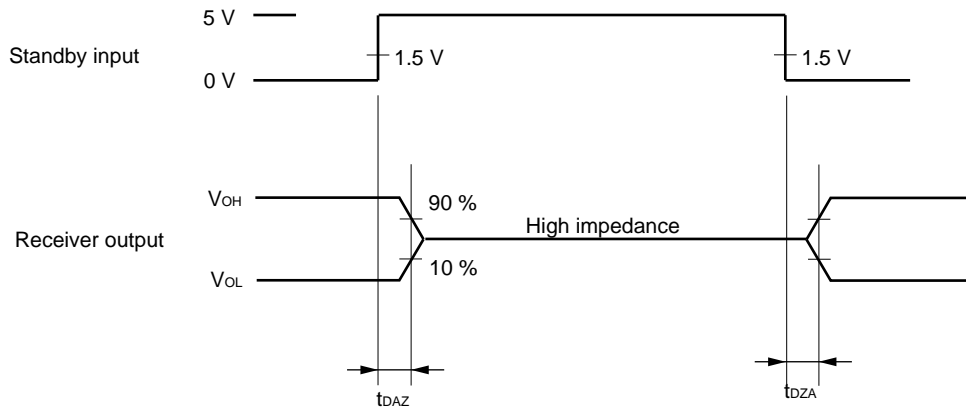

The receiver output is undefined during the standby output transition time t_{DZA}. Do not perform communication in the standby output transition time t_{DZA} on power application or on releasing the standby mode.

TEST CIRCUIT

Driver output voltage/Output current (+ side)

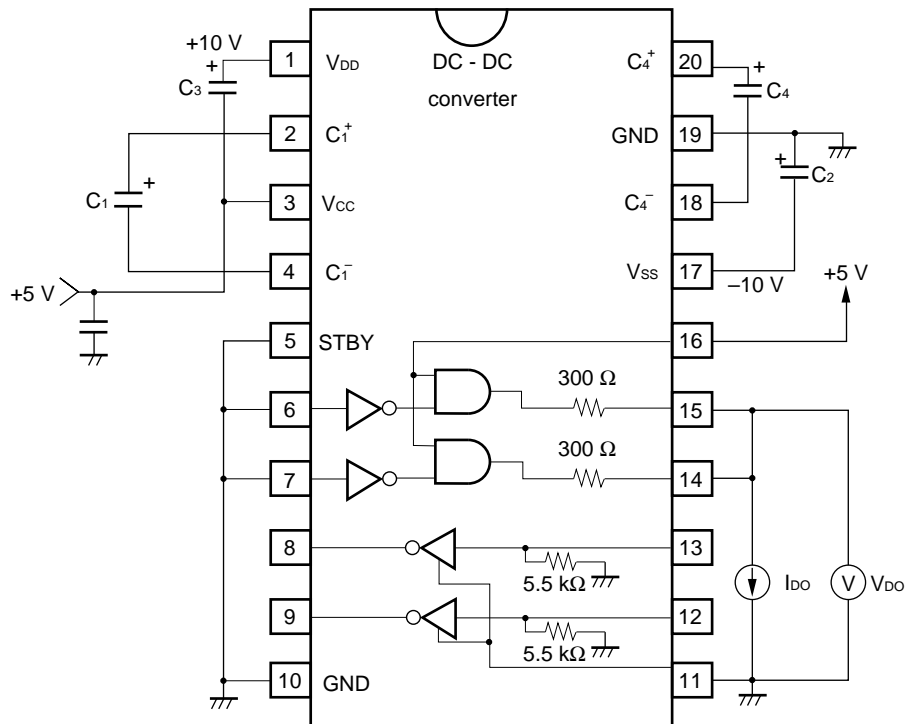

Driver output voltage/Output current (- side)

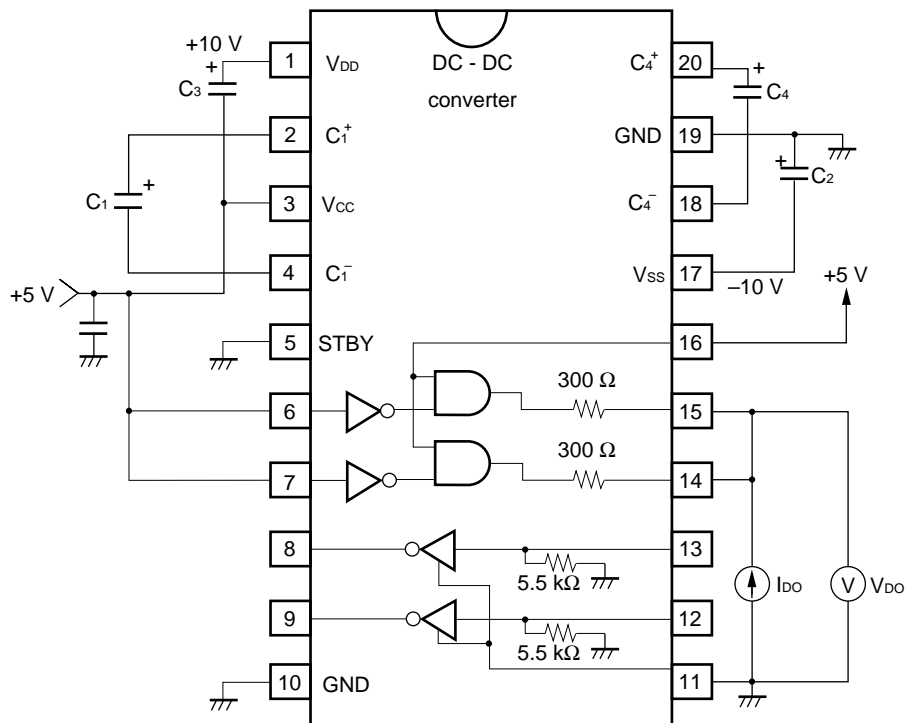

PACKAGE DRAWINGS

20PIN PLASTIC DIP (300 mil)

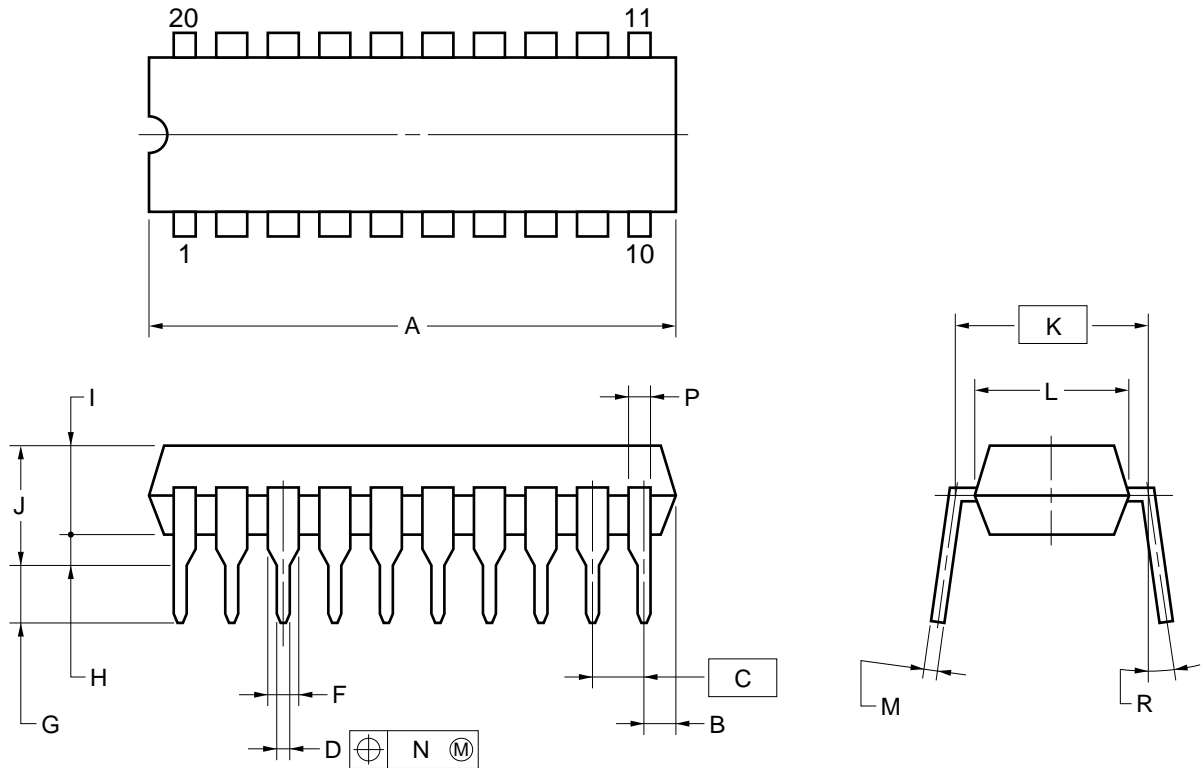

NOTES

- 1) Each lead centerline is located within 0.25 mm (0.01 inch) of its true position (T.P.) at maximum material condition.
- 2) Item "K" to center of leads when formed parallel.

ITEM	MILLIMETERS	INCHES
A	25.40 MAX.	1.000 MAX.
B	1.27 MAX.	0.050 MAX.
C	2.54 (T.P.)	0.100 (T.P.)
D	0.50±0.10	0.020 ^{+0.004} _{-0.005}
F	1.1 MIN.	0.043 MIN.
G	3.5±0.3	0.138±0.012
H	0.51 MIN.	0.020 MIN.
I	4.31 MAX.	0.170 MAX.
J	5.08 MAX.	0.200 MAX.
K	7.62 (T.P.)	0.300 (T.P.)
L	6.4	0.252
M	0.25 ^{+0.10} _{-0.05}	0.010 ^{+0.004} _{-0.003}
N	0.25	0.01
P	0.9 MIN.	0.035 MIN.
R	0~15°	0~15°

P20C-100-300A,C-1

20 PIN PLASTIC SOP (300 mil)

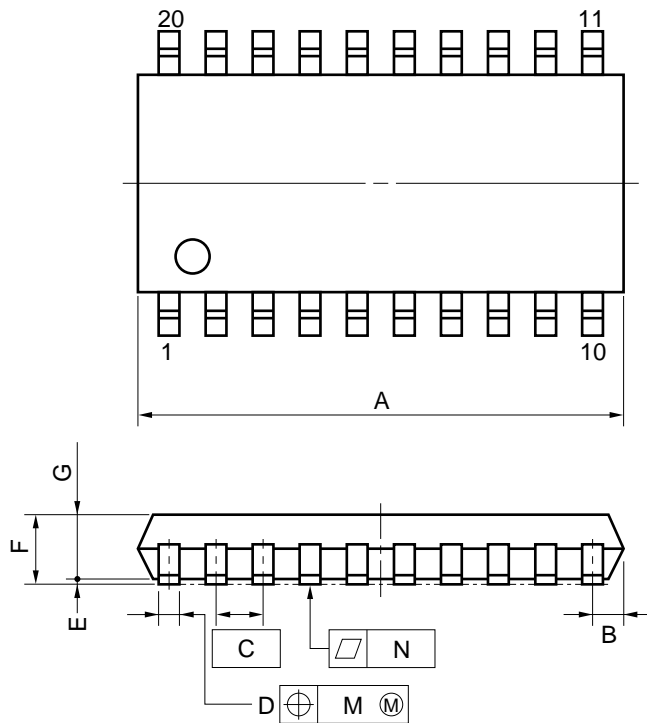

detail of lead end

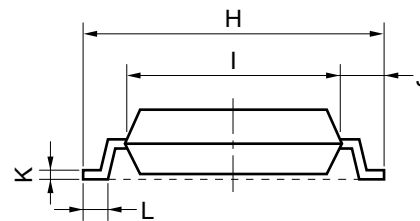
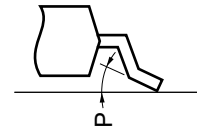

NOTE

Each lead centerline is located within 0.12 mm (0.005 inch) of its true position (T.P.) at maximum material condition.

ITEM	MILLIMETERS	INCHES
A	13.00 MAX.	0.512 MAX.
B	0.78 MAX.	0.031 MAX.
C	1.27 (T.P.)	0.050 (T.P.)
D	0.40 ^{+0.10} _{-0.05}	0.016 ^{+0.004} _{-0.003}
E	0.1±0.1	0.004±0.004
F	1.8 MAX.	0.071 MAX.
G	1.55	0.061
H	7.7±0.3	0.303±0.012
I	5.6	0.220
J	1.1	0.043
K	0.20 ^{+0.10} _{-0.05}	0.008 ^{+0.004} _{-0.002}
L	0.6±0.2	0.024 ^{+0.008} _{-0.009}
M	0.12	0.005
N	0.10	0.004
P	3° ^{+7°} _{-3°}	3° ^{+7°} _{-3°}

P20GM-50-300B, C-4

RECOMMENDED SOLDERING CONDITIONS

Soldering the μPD4711B under the conditions listed in the table below is recommended.

For soldering methods and conditions other than those recommended, consult NEC.

Surface mount type

For the details of the recommended soldering conditions of the surface mount type, refer to Information document “Semiconductor Device Mounting Technology Manual” C10535EJ7V0IF00.

μPD4711BGS

Soldering Method	Soldering Condition	Recommended Condition Symbol
Infrared reflow	Package peak temperature: 235 °C, Time: 30 seconds MAX. (210 °C MIN.), Number of times: 2, Number of days: not limited*	IR35-00-2
VPS	Package peak temperature: 215 °C, Time: 40 seconds MAX. (200 °C MIN.), Number of times: 2, Number of days: not limited*	VP15-00-2
Wave soldering	Soldering bath temperature: 260 °C MAX., Time: 10 seconds MAX., Number of times: 1, Number of days: not limited*	WS60-00-1
Pin partial heating	Pin temperature: 300 °C MAX (lead temperature), Time: 3 seconds MAX. (per lead pin), Number of days: not limited*	

* The number of days the device can be stored at 25 °C, 65 % RH MAX. after the dry pack has been opened.

Caution Do not use two or more soldering methods in combination (except the pin partial heating method).

Through-hole type

μPD4711BCX

Soldering Method	Soldering Conditions
Wave soldering	Soldering bath temperature: 260 °C MAX., Time: 10 seconds MAX.

Reference documents

“NEC Semiconductor Device Reliability/Quality Control System” (IEI-1212)

“Quality Grade on NEC Semiconductor Devices” (IEI-1209)

“Semiconductor Device Mounting Technology Manual” C10535EJ7V0IF00

[MEMO]

No part of this document may be copied or reproduced in any form or by any means without the prior written consent of NEC Corporation. NEC Corporation assumes no responsibility for any errors which may appear in this document.

NEC Corporation does not assume any liability for infringement of patents, copyrights or other intellectual property rights of third parties by or arising from use of a device described herein or any other liability arising from use of such device. No license, either express, implied or otherwise, is granted under any patents, copyrights or other intellectual property rights of NEC Corporation or others.

While NEC Corporation has been making continuous effort to enhance the reliability of its semiconductor devices, the possibility of defects cannot be eliminated entirely. To minimize risks of damage or injury to persons or property arising from a defect in an NEC semiconductor device, customers must incorporate sufficient safety measures in its design, such as redundancy, fire-containment, and anti-failure features.

NEC devices are classified into the following three quality grades:

"Standard", "Special", and "Specific". The Specific quality grade applies only to devices developed based on a customer designated "quality assurance program" for a specific application. The recommended applications of a device depend on its quality grade, as indicated below. Customers must check the quality grade of each device before using it in a particular application.

Standard: Computers, office equipment, communications equipment, test and measurement equipment, audio and visual equipment, home electronic appliances, machine tools, personal electronic equipment and industrial robots

Special: Transportation equipment (automobiles, trains, ships, etc.), traffic control systems, anti-disaster systems, anti-crime systems, safety equipment and medical equipment (not specifically designed for life support)

Specific: Aircrafts, aerospace equipment, submersible repeaters, nuclear reactor control systems, life support systems or medical equipment for life support, etc.

The quality grade of NEC devices is "Standard" unless otherwise specified in NEC's Data Sheets or Data Books. If customers intend to use NEC devices for applications other than those specified for Standard quality grade, they should contact an NEC sales representative in advance.

Anti-radioactive design is not implemented in this product.