

RS-232 LINE DRIVER/RECEIVER AT 3.3 V/5 V

The μ PD4722 is a high-breakdown voltage silicon gate CMOS line driver/receiver based on the EIA/TIA-232-E standard. The internal DC/DC converter can switch between multiple voltages, allowing it to operate with a single +3.3 V or +5 V power supply. It also provides standby function.

This IC incorporates 4 driver circuits and 4 receiver circuits. An RS-232 interface circuit can be easily configured by connecting 5 capacitors externally.

FEATURES

- Conforms to EIA/TIA-232-E (former name, RS-232C) standards
- Selectable +3.3 V/+5 V single power supply (selected by V_{CHA} pin)
- By setting the standby pin to a low level (standby mode), circuit current can be reduced. At such times, the driver output is in a high-impedance state.
- Even in the standby mode, 2 receiver circuits can operate as inverters without hysteresis width. The other 2 circuits are fixed at a high level.

ORDERING INFORMATION

Part number	Package
μ PD4722GS-GJG	30-pin plastic SSOP (300 mil)

BLOCK DIAGRAM/PIN CONFIGURATION (TOP VIEW)

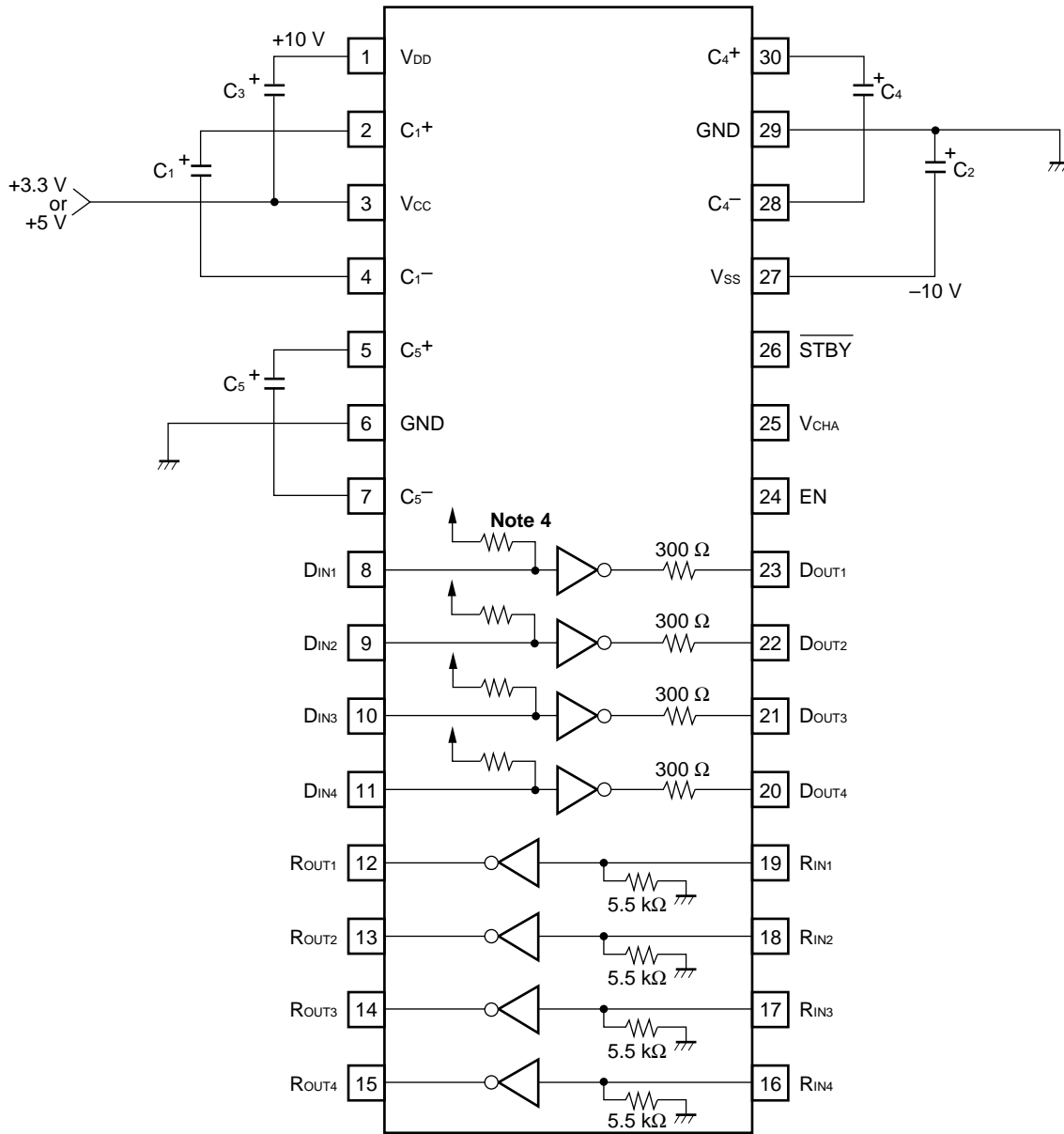

- Note**
1. V_{DD} and V_{SS} are output pins stepped up internally. These pins should not be loaded directly.
 2. Capacitors C₁ to C₅ with a breakdown voltage of 20 V or higher are recommended. And it is recommended to insert the capacitor that is 0.1 μF to 1 μF between V_{CC} and GND.
 3. If V_{CHA} is kept low level (in 5 V mode), capacitor C₅ is not necessary.
 4. The pull-up resistors at driver input are active resistors.

Truth Table

Driver

$\overline{\text{STBY}}$	D _{IN}	D _{OUT}	Remarks
L	×	Z	Standby mode (DC/DC converter is stopped)
H	L	H	Space level output
H	H	L	Mark level output

Receiver

$\overline{\text{STBY}}$	EN	R _{IN}		R _{OUT}		Remarks
		R ₃ to R ₄	R ₁ to R ₂	R ₃ to R ₄	R ₁ to R ₂	
L	L	×	×	H	H	Standby mode 1 (DC/DC converter is stopped)
L	H	L	×	H	H	Standby mode 2 (DC/DC converter is stopped, R ₃ and R ₄ are operated)
L	H	H	×	L	H	Standby mode 2 (DC/DC converter is stopped, R ₃ and R ₄ are operated)
H	×	L		H		Mark level input
H	×	H		L		Space level input

3 V ↔ 5 V switching^{Note 5}

V _{CHA}	Operating mode
L	5 V mode (double step-up)
H	3 V mode (3 times step-up)

H: high-level, L: low-level, Z: high-impedance, ×: H or L

Note 5. When switching V_{CHA}, standby mode must be selected ($\overline{\text{STBY}} = \text{L}$).

ABSOLUTE MAXIMUM RATINGS (T_A = 25 °C)

Parameter	Symbol	Ratings	Unit
Supply Voltage (V _{CHA} = L)	V _{CC}	-0.5 to +7.0	V
Supply Voltage (V _{CHA} = H)	V _{CC}	-0.5 to +4.5	V
Driver Input Voltage	D _{IN}	-0.5 to V _{CC} +0.5	V
Receiver Input Voltage	R _{IN}	-30.0 to +30.0	V
Control Input Voltage ($\overline{\text{STBY}}$, V _{CHA} , EN)	V _{IN}	-0.5 to V _{CC} +0.5	V
Driver Output Voltage	D _{OUT}	-25.0 to +25.0 ^{Note 6}	V
Receiver Output Voltage	R _{OUT}	-0.5 to V _{CC} +0.5	V
Input Current (D _{IN} , $\overline{\text{STBY}}$, V _{CHA} , EN)	I _{IN}	±20.0	mA
Operating Ambient Temperature	T _A	-40 to +85	°C
Storage Temperature	T _{stg}	-55 to + 150	°C
Total Power Dissipation	P _T	0.5	W

Note 6. Pulse width = 1 ms, duty = 10 % MAX.

RECOMMENDED OPERATING CONDITIONS

Parameter	Symbol	MIN.	TYP.	MAX.	Unit
Supply Voltage (V _{CHA} = L, 5 V mode)	V _{CC}	4.5	5.0	5.5	V
Supply Voltage (V _{CHA} = H, 3 V mode)	V _{CC}	3.0	3.3	3.6	V
High-Level Input Voltage (D _{IN})	V _{IH}	2.0		V _{CC}	V
Low-Level Input Voltage (D _{IN})	V _{IL}	0		0.8	V
High-Level Input Voltage ($\overline{\text{STBY}}$, V _{CHA} , EN)	V _{IH}	2.4		V _{CC}	V
Low-Level Input Voltage ($\overline{\text{STBY}}$, V _{CHA} , EN)	V _{IL}	0		0.6	V
Receiver Input Voltage	R _{IN}	-30		+30	V
Operating Ambient Temperature	T _A	-40		+85	°C
Capacitance of External Capacitor	Note 7	0.47		4.7	μF

Note 7. In low temperature (below 0 °C), the capacitance of electrolytic capacitor becomes lower. Therefore, set higher values when using in low temperature.

Concerning the wiring length between the capacitor and the IC, the shorter the better.

Capacitors with good frequency characteristics such as tantalum capacitors, laminated ceramic capacitors, and aluminum electrolytic capacitors for switching power supply are recommended for the external capacitors.

ELECTRICAL SPECIFICATIONS (TOTAL)

(UNLESS OTHERWISE SPECIFIED, $T_A = -40$ to $+85$ °C, C_1 to $C_5 = 1$ μF)

Parameter	Symbol	Conditions	MIN.	TYP.	MAX.	Unit
Circuit Current	I _{CC1}	V _{CC} = +3.3 V, No load, R _{IN} pin OPEN, $\overline{STBY} = H$			16	mA
		V _{CC} = +5.0 V, No load, R _{IN} pin OPEN, $\overline{STBY} = H$			12	mA
Circuit Current	I _{CC2}	V _{CC} = +3.3 V, R _L = 3 kΩ (D _{OUT}), D _{IN} = GND, R _{IN} , R _{OUT} pin OPEN, $\overline{STBY} = H$			47	mA
		V _{CC} = +5.0 V, R _L = 3 kΩ (D _{OUT}), D _{IN} = GND, R _{IN} , R _{OUT} pin OPEN, $\overline{STBY} = H$			38	mA
Circuit Current at Standby (Standby Mode 1)	I _{CC3}	V _{CC} = +3.3 V, No load, D _{IN} and R _{IN} pins are OPEN, $\overline{STBY} = L$, EN = L, T _A = 25 °C		1	3	μA
		V _{CC} = +3.3 V, No load, D _{IN} and R _{IN} pins are OPEN, $\overline{STBY} = L$, EN = L		5		μA
		V _{CC} = +5.0 V, No load, D _{IN} and R _{IN} pins are OPEN, $\overline{STBY} = L$, EN = L, T _A = 25 °C		2	5	μA
		V _{CC} = +5.0 V, No load, D _{IN} and R _{IN} pins are OPEN, $\overline{STBY} = L$, EN = L		10		μA
Circuit Current at Standby (Standby Mode 2)	I _{CC4}	V _{CC} = +3.3 V, No load, D _{IN} and R _{IN} pins are OPEN, $\overline{STBY} = L$, EN = H, T _A = 25 °C		1	3	μA
		V _{CC} = +3.3 V, No load, D _{IN} and R _{IN} pins are OPEN, $\overline{STBY} = L$, EN = H		5		μA
		V _{CC} = +5.0 V, No load, D _{IN} and R _{IN} pins are OPEN, $\overline{STBY} = L$, EN = H, T _A = 25 °C		2	5	μA
		V _{CC} = +5.0 V, No load, D _{IN} and R _{IN} pins are OPEN, $\overline{STBY} = L$, EN = H		10		μA
High-Level Input Voltage	V _{IH}	V _{CC} = +3.0 to +5.5 V, \overline{STBY} , V _{CHA} , EN pin	2.4			V
Low-Level Input Voltage	V _{IL}	V _{CC} = +3.0 to +5.5 V, \overline{STBY} , V _{CHA} , EN pin			0.6	V
High-Level Input Current	I _{IH}	V _{CC} = +5.5 V, V _I = 5.5 V, \overline{STBY} , V _{CHA} , EN pin			1	μA
Low-Level Input Current	I _{IL}	V _{CC} = +5.5 V, V _I = 0 V, \overline{STBY} , V _{CHA} , EN pin			-1	μA
Input Capacitance	C _{IN}	Driver input and receiver input V _{CC} = +3.3 V, for GND, f = 1 MHz			10	pF
		Driver input and receiver input V _{CC} = +5.0 V, for GND, f = 1 MHz			10	pF
$\overline{STBY} - V_{CHA}$ Time	t _{SCH}	V _{CC} = +3.0 to 5.5 V, $\overline{STBY} \downarrow \rightarrow V_{CHA}$, Note 8	1			μs
V _{CHA} - \overline{STBY} Time	t _{CHS}	V _{CC} = +3.0 to 5.5 V, V _{CHA} → $\overline{STBY} \uparrow$, Note 8	1			μs
$\overline{STBY} - V_{CC}$ Time	t _{SC}	V _{CC} = +3.0 to 5.5 V, $\overline{STBY} \downarrow \rightarrow V_{CC}$, Note 8	1			μs
V _{CC} - \overline{STBY} Time	t _{CS}	V _{CC} = +3.0 to 5.5 V, V _{CC} → $\overline{STBY} \uparrow$, Note 8	1			μs

* The TYP. values are for reference at T_A = 25 °C.

Note 8. Measuring point

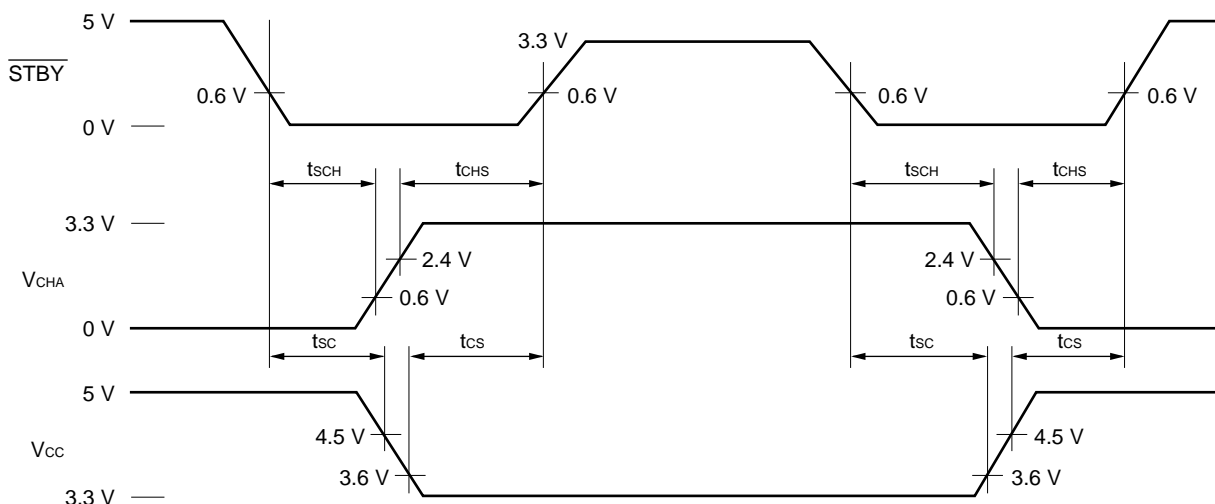

ELECTRICAL SPECIFICATIONS (DRIVER)

(UNLESS OTHERWISE SPECIFIED, $T_A = -40$ to $+85$ °C, C_1 to $C_5 = 1$ μF)

3 V mode (unless otherwise specified, $V_{CHA} = H$, $V_{CC} = 3.0$ to 3.6 V)

Parameter	Symbol	Conditions	MIN.	TYP.	MAX.	Unit
Low-Level Input Voltage	V_{IL}				0.8	V
High-Level Input Voltage	V_{IH}		2.0			V
Low-Level Input Current	I_{IL}	$V_{CC} = +3.6$ V, $V_I = 0$ V			-25	μA
High-Level Input Current	I_{IH}	$V_{CC} = +3.6$ V, $V_I = 3.6$ V			1.0	μA
Output Voltage	V_{DO}	$V_{CC} = +3.3$ V, $R_L = \infty$, $T_A = 25$ °C		±9.5		V
		$V_{CC} = +3.3$ V, $R_L = 3$ kΩ, $T_A = T_{opt}$	±5.0	±6.0		V
		$V_{CC} = +3.0$ V, $R_L = 3$ kΩ, $T_A = +25$ °C	±5.0			V
Output Short-Circuit Current	I_{sc}	$V_{CC} = +3.3$ V, for GND			±40	mA
Slew-Rate ^{Note 9}	SR	$C_L = 10$ pF, $R_L = 3$ to 7 kΩ	3.0		30	V/μs
		$C_L = 2\ 500$ pF, $R_L = 3$ to 7 kΩ	3.0		30	V/μs
Propagation Delay Time ^{Note 9}	t_{PHL} t_{PLH}	$R_L = 3$ kΩ, $C_L = 2\ 500$ pF		2.5		μs
Output Resistor	R_O	$V_{CC} = V_{DD} = V_{SS} = 0$ V $V_{OUT} = \pm 2$ V	300			Ω
Standby Output Transfer Time	t_{DAZ}	$R_L = 3$ kΩ, $C_L = 2\ 500$ pF, ^{Note 10}		4	10	μs
Standby Output Transfer Time	t_{DZA}	$R_L = 3$ kΩ, $C_L = 2\ 500$ pF, ^{Note 10}		1	3	ms
Power-On Output Transfer Time	t_{PRA}	$R_L = 3$ kΩ, $C_L = 2\ 500$ pF, ^{Note 11}		1	3	ms

* The TYP. values are for reference at $T_A = 25$ °C.

5 V mode (unless otherwise specified, $V_{CHA} = L$, $V_{CC} = +5.0 \text{ V} \pm 10 \%$)

Parameter	Symbol	Conditions	MIN.	TYP.	MAX.	Unit
Low-Level Input Voltage	V_{IL}				0.8	V
High-Level Input Voltage	V_{IH}		2.0			V
Low-Level Input Current	I_{IL}	$V_{CC} = +5.5 \text{ V}$, $V_i = 0 \text{ V}$			-40	μA
High-Level Input Current	I_{IH}	$V_{CC} = +5.5 \text{ V}$, $V_i = 5.5 \text{ V}$			1.0	μA
Output Voltage	V_{DO}	$V_{CC} = +5.0 \text{ V}$, $R_L = \infty$, $T_A = 25 \text{ }^\circ\text{C}$		±9.7		V
		$V_{CC} = +5.0 \text{ V}$, $R_L = 3 \text{ k}\Omega$, $T_A = T_{opt}$	±6.0			V
		$V_{CC} = +4.5 \text{ V}$, $R_L = 3 \text{ k}\Omega$, $T_A = T_{opt}$	±5.0			V
Output Short-Circuit Current	I_{SC}	$V_{CC} = +5.0 \text{ V}$, for GND			±40	mA
Slew-Rate ^{Note 9}	SR	$C_L = 10 \text{ pF}$, $R_L = 3 \text{ to } 7 \text{ k}\Omega$	4.0		30	V/μs
		$C_L = 2\,500 \text{ pF}$, $R_L = 3 \text{ to } 7 \text{ k}\Omega$	4.0		30	V/μs
Propagation Delay Time ^{Note 9}	t_{PHL} t_{PLH}	$R_L = 3 \text{ k}\Omega$, $C_L = 2\,500 \text{ pF}$		2		μs
Output Resistor	R_O	$V_{CC} = V_{DD} = V_{SS} = 0 \text{ V}$ $V_{OUT} = \pm 2 \text{ V}$	300			Ω
Standby Output Transfer Time	t_{DAZ}	$R_L = 3 \text{ k}\Omega$, $C_L = 2\,500 \text{ pF}$, ^{Note 10}		4	10	μs
Standby Output Transfer Time	t_{DZA}	$R_L = 3 \text{ k}\Omega$, $C_L = 2\,500 \text{ pF}$, ^{Note 10}		0.5	1	ms
Power-On Output Transfer Time	t_{PRA}	$R_L = 3 \text{ k}\Omega$, $C_L = 2\,500 \text{ pF}$, ^{Note 12}		0.5	1	ms

* The TYP. values are for reference at $T_A = 25 \text{ }^\circ\text{C}$.

Note 9. Measuring point

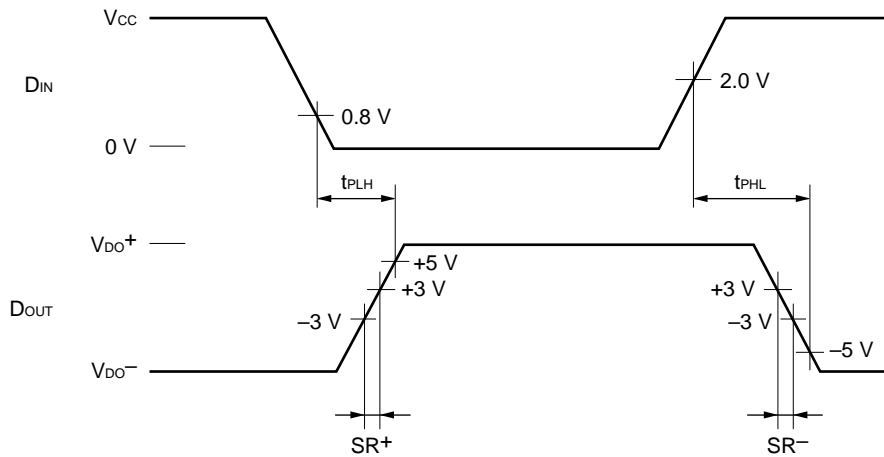

Note 10. Measuring point

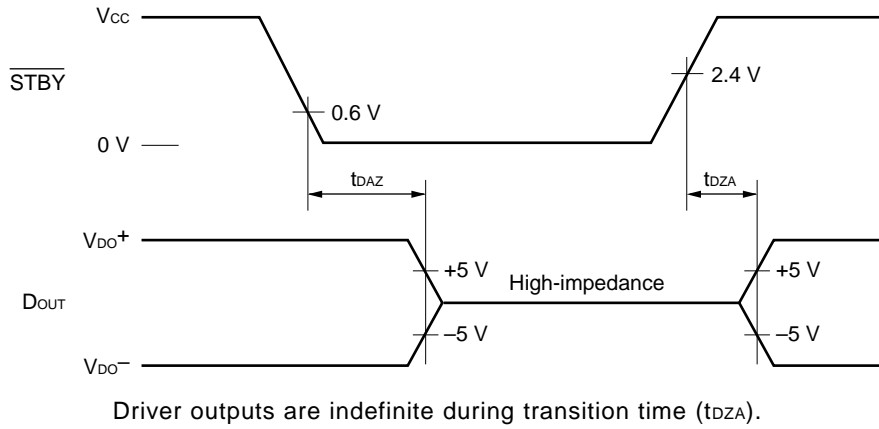

Note 11. Measuring point

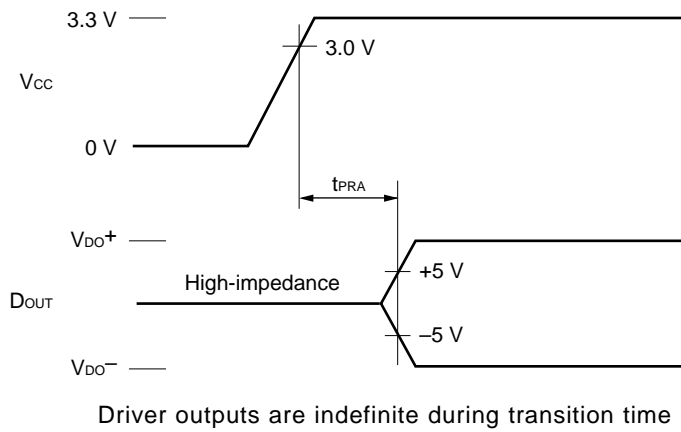

Note 12. Measuring point

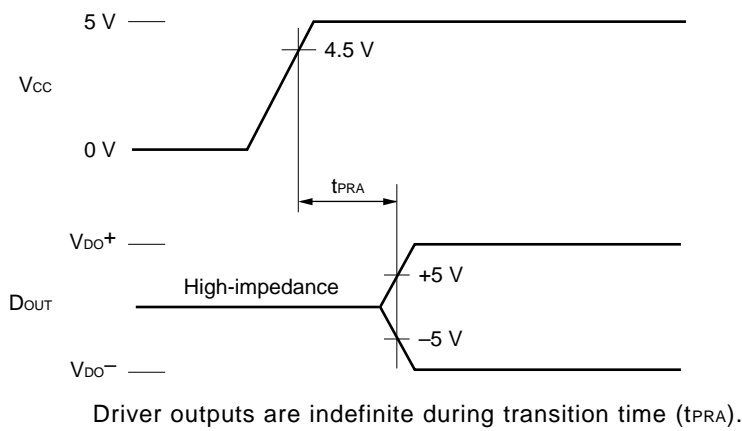

ELECTRICAL SPECIFICATIONS (RECEIVER)

(UNLESS OTHERWISE SPECIFIED, $V_{CC} = 3.0$ to 5.5 V, $T_A = -40$ to $+85$ °C, C_1 to $C_5 = 1$ μF)

Parameter	Symbol	Conditions	MIN.	TYP.	MAX.	Unit
Low-Level Output Voltage	V_{OL1}	$I_{OUT} = 4$ mA, $\overline{STBY} = H$			0.4	V
High-Level Output Voltage	V_{OH1}	$I_{OUT} = -4$ mA, $\overline{STBY} = H$	$V_{CC} - 0.4$			V
Low-Level Output Voltage	V_{OL2}	$I_{OUT} = 4$ mA, $\overline{STBY} = L$			0.5	V
High-Level Output Voltage	V_{OH2}	$I_{OUT} = -4$ mA, $\overline{STBY} = L$	$V_{CC} - 0.5$			V
Propagation Delay Time ($\overline{STBY} = H$)	t_{PHL} t_{PLH}	$R_{IN} \rightarrow R_{OUT}$, $C_L = 150$ pF $V_{CC} = +3.0$ V, Note 13		0.2		μs
Propagation Delay Time ($\overline{STBY} = L$)	t_{PHL} t_{PLH}	$R_{IN} \rightarrow R_{OUT}$, $C_L = 150$ pF $V_{CC} = +3.0$ V, Note 14		0.1		μs
Propagation Delay Time ($\overline{STBY} = L$)	t_{PHA} t_{PAH}	$EN \rightarrow R_{OUT}$, $C_L = 150$ pF $V_{CC} = +3.0$ V, Note 15		100	300	ns
Input Resistor	R_I		3	5.5	7	kΩ
Input Pin Open Voltage	V_{IO}				0.5	V
Input Threshold ($\overline{STBY} = H$)	V_{IH}	$V_{CC} = +3.0$ to $+5.5$ V	1.7	2.3	2.7	V
	V_{IL}	$V_{CC} = +3.0$ to $+5.5$ V	0.7	1.1	1.7	V
	V_H	$V_{CC} = +3.0$ to $+5.5$ V (Hysteresis width)	0.5	1.2	1.8	V
Input Threshold ($\overline{STBY} = L$, $EN = H$)	V_{IH}	$V_{CC} = +3.0$ to $+5.5$ V, R_{IN3} , R_{IN4}	2.7	1.5		V
	V_{IL}	$V_{CC} = +3.0$ to $+5.5$ V, R_{IN3} , R_{IN4}		1.5	0.7	V
Standby Output Transfer Time	t_{DAH}	Note 16		0.2	3	μs
Standby Output Transfer Time	t_{DHA}	$V_{CHA} = H$ (3 V mode) Note 16		0.6	3	ms
		$V_{CHA} = L$ (5 V mode) Note 16		0.3	1	ms
Power-On Reset Release Time	t_{PRA}	$V_{CHA} = H$ (3 V mode) Note 17		1	3	ms
		$V_{CHA} = L$ (5 V mode) Note 18		0.5	1	ms

* The TYP. values are for reference at $T_A = 25$ °C.

Note 13. Measuring point

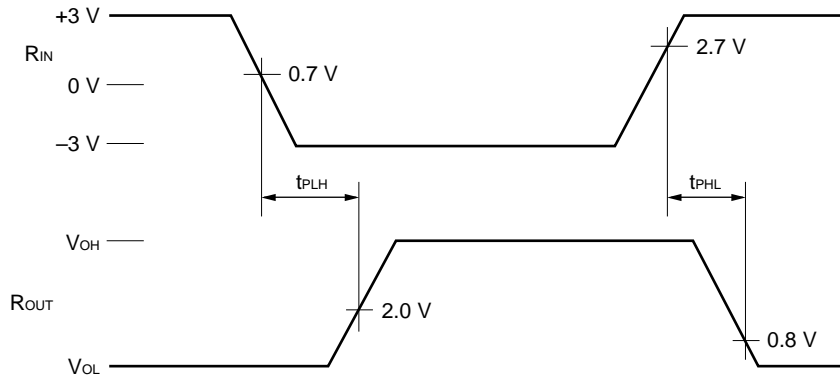

Note 14. Measuring point

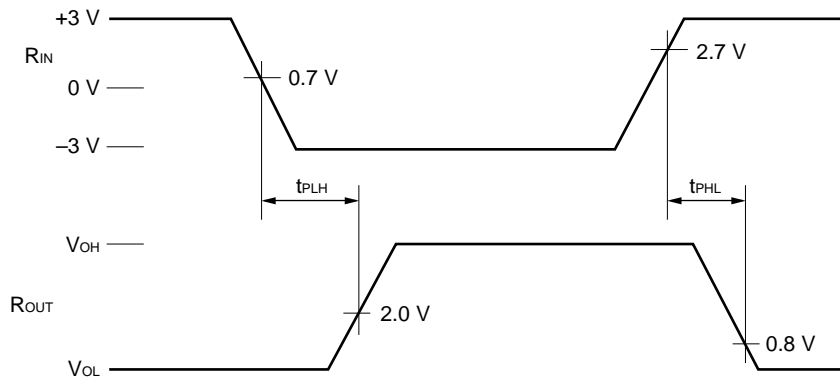

Note 15. Measuring point

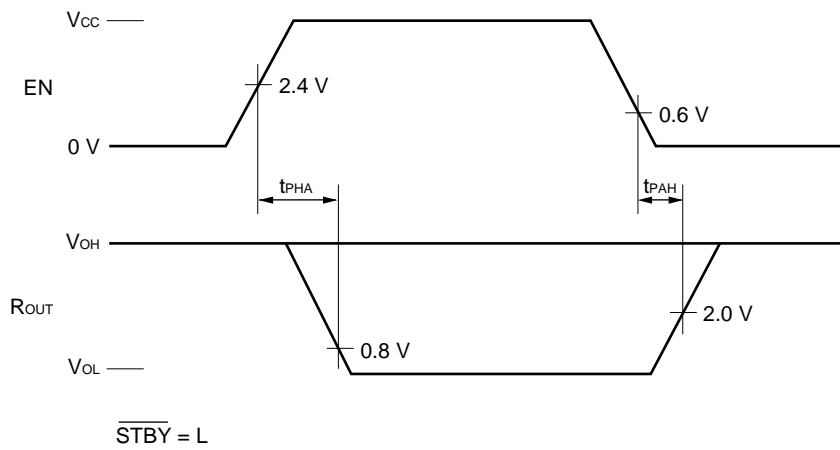

Note 16. Measuring point

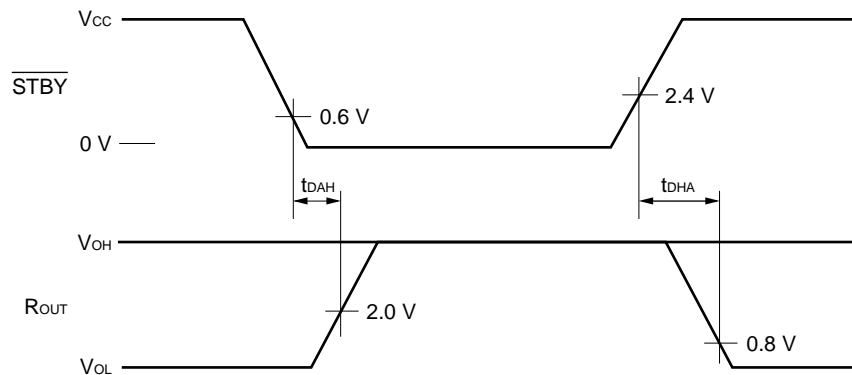

Receiver outputs are indefinite during transition time (t_{DHA}).

Note 17. Measuring point

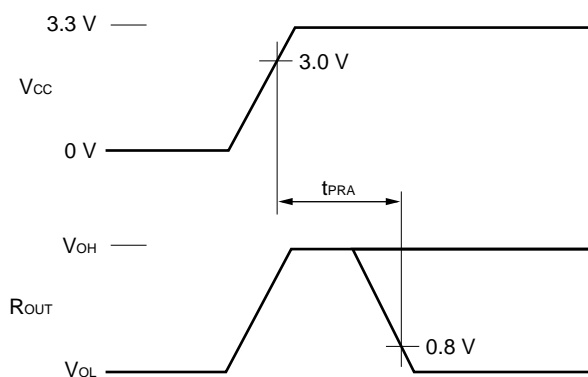

Receiver outputs are indefinite during reset release time (t_{PRA}).

Note 18. Measuring point

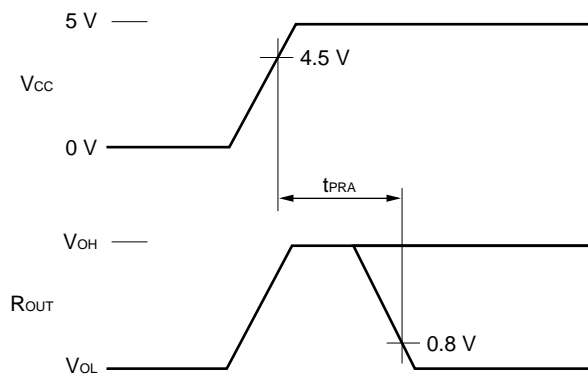

Receiver outputs are indefinite during reset release time (t_{PRA}).

REFERENCE MATERIAL

- IC PACKAGE MANUAL (C10943X)
- NEC SEMICONDUCTOR DEVICE RELIABILITY/QUALITY (IEI-1212)

RECOMMENDED SOLDERING CONDITIONS

The following conditions (See table below) must be met when soldering this product.

Please consult with our sales offices in case other soldering process is used, or in case soldering is done under different conditions.

TYPES OF SURFACE MOUNT DEVICE

For more details, refer to our document “SMT MANUAL” (C10535E).

μPD4722 GS-GJG

Soldering process	Soldering conditions	Symbol
Infrared ray reflow	Peak package's surface temperature: 230 °C or below, Reflow time: 30 seconds or below (210 °C or higher), Number of reflow process: 2, Exposure limit*: None	IR30-00-2
VPS	Peak package's surface temperature: 215 °C or below, Reflow time: 40 seconds or below (200 °C or higher), Number of reflow process: 2, Exposure limit*: None	VP15-00-2
Wave soldering	Solder temperature: 260 °C or below, Flow time: 10 seconds or below, Number of flow process: 1, Exposure limit*: None	WS60-00-1
Partial heating method	Terminal temperature: 300 °C or below, Flow time: 10 seconds or below, Exposure limit*: None	○

* Exposure limit before soldering after dry-pack package is opened.
Storage conditions: 25 °C and relative humidity at 65 % or less.

Note Do not apply more than a single process at once, except for “Partial heating method”

PACKAGE DRAWINGS

30 PIN PLASTIC SHRINK SOP (300 mil)

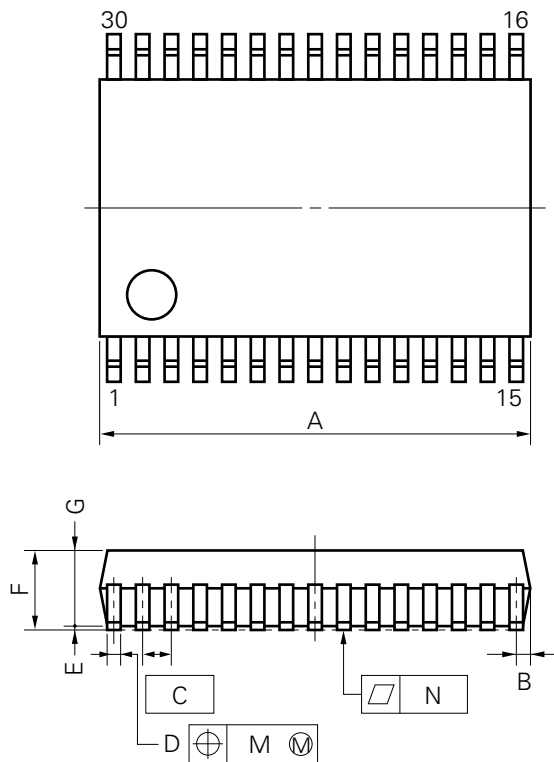

detail of lead end

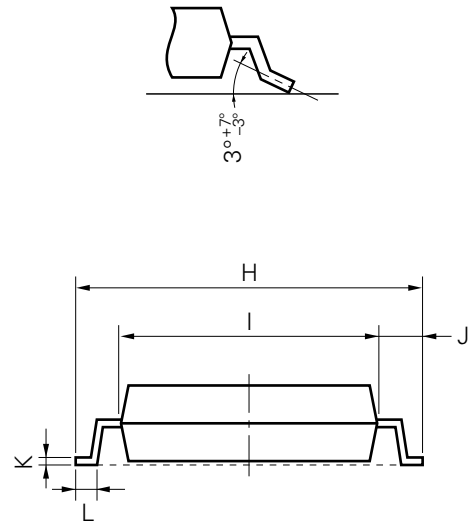

NOTE

Each lead centerline is located within 0.10 mm (0.004 inch) of its true position (T.P.) at maximum material condition.

P30GS-65-300B-1

ITEM	MILLIMETERS	INCHES
A	10.11 MAX.	0.398 MAX.
B	0.51 MAX.	0.020 MAX.
C	0.65 (T.P.)	0.026 (T.P.)
D	0.30 ^{+0.10} _{-0.05}	0.012 ^{+0.004} _{-0.003}
E	0.125±0.075	0.005±0.003
F	2.0 MAX.	0.079 MAX.
G	1.7±0.1	0.067±0.004
H	8.1±0.2	0.319±0.008
I	6.1±0.2	0.240±0.008
J	1.0±0.2	0.039 ^{+0.008} _{-0.008}
K	0.15 ^{+0.10} _{-0.05}	0.006 ^{+0.004} _{-0.002}
L	0.5±0.2	0.020 ^{+0.008} _{-0.009}
M	0.10	0.004
N	0.10	0.004

[MEMO]

[MEMO]

No part of this document may be copied or reproduced in any form or by any means without the prior written consent of NEC Corporation. NEC Corporation assumes no responsibility for any errors which may appear in this document.

NEC Corporation does not assume any liability for infringement of patents, copyrights or other intellectual property rights of third parties by or arising from use of a device described herein or any other liability arising from use of such device. No license, either express, implied or otherwise, is granted under any patents, copyrights or other intellectual property rights of NEC Corporation or others.

While NEC Corporation has been making continuous effort to enhance the reliability of its semiconductor devices, the possibility of defects cannot be eliminated entirely. To minimize risks of damage or injury to persons or property arising from a defect in an NEC semiconductor device, customers must incorporate sufficient safety measures in its design, such as redundancy, fire-containment, and anti-failure features.

NEC devices are classified into the following three quality grades:

"Standard", "Special", and "Specific". The Specific quality grade applies only to devices developed based on a customer designated "quality assurance program" for a specific application. The recommended applications of a device depend on its quality grade, as indicated below. Customers must check the quality grade of each device before using it in a particular application.

Standard: Computers, office equipment, communications equipment, test and measurement equipment, audio and visual equipment, home electronic appliances, machine tools, personal electronic equipment and industrial robots

Special: Transportation equipment (automobiles, trains, ships, etc.), traffic control systems, anti-disaster systems, anti-crime systems, safety equipment and medical equipment (not specifically designed for life support)

Specific: Aircrafts, aerospace equipment, submersible repeaters, nuclear reactor control systems, life support systems or medical equipment for life support, etc.

The quality grade of NEC devices is "Standard" unless otherwise specified in NEC's Data Sheets or Data Books. If customers intend to use NEC devices for applications other than those specified for Standard quality grade, they should contact an NEC sales representative in advance.

Anti-radioactive design is not implemented in this product.