

SECOND GENERATION ENHANCED MULTIMEDIA ARCHITECTURE PROCESSOR FOR DVD RECORDER/PERSONAL VIDEO RECORDERS

DESCRIPTION

The μ PD61171 is a fully-integrated system processor for DVD recorders or personal video recorders (PVR). Based on NEC Electronics' second-generation Enhanced Multi Media Architecture (EMMArchitecture), the μ PD61171 provides the functionality required to realize a high-performance and cost-effective DVD recorder or PVR.

FEATURES

- DVD-Video, DVD-Video Recording compliant
- DVB, MPEG2-TS/PS and MPEG1 compliant codec
- Dolby™ digital audio codec, DTS™ audio decoder
- High performance, dual MIPS32™ CPU core: 225 MIPS at 187 MHz
- High-bandwidth unified memory controller to support external DDR SDRAM
- Flexible multi-standard, multi-stream processor
- Integrated CSS and CPPM decryption
- Integrated CPRM and DES encryption/decryption
- Integrated Multi-2 and DVB descrambler
- Dual storage interfaces for ATA UDMA100-compliant HDD and ATAPI DVD drive
- Real time VBR/CBR encoding
- 3D noise reduction filter and motion-adaptive de-interlacer
- 7 graphics planes with dual video scalars
- Simultaneous progressive and interlace video outputs: 6 DACs for YPbPr (or YCbCr or RGB), S-Video (Y/C) and CVBS output with support for NTSC, PAL and SECAM
- Multi-channel audio outputs: IEC60958 and PCM with support for up to 8 channels
- Selectable host bus interface: Generic 16-bit host bus or PCI bus

APPLICATIONS

DVD recorders, personal video recorders, home servers

ORDERING INFORMATION

Part number	Package	Remark
μ PD61171F1-XYZ-MN2-A	449-pin plastic BGA (27 × 27)	XYZ: Audio option

**“Dolby” and “Dolby Digital” are trademarks of Dolby Laboratories.
To use the μ PD61171, a license from Dolby Laboratories Licensing Corporation is necessary.**

The information contained in this document is being issued in advance of the production cycle for the product. The parameters for the product may change before final production or NEC Electronics Corporation, at its own discretion, may withdraw the product prior to its production. Not all products and/or types are available in every country. Please check with an NEC Electronics sales representative for availability and additional information.

TYPICAL APPLICATION

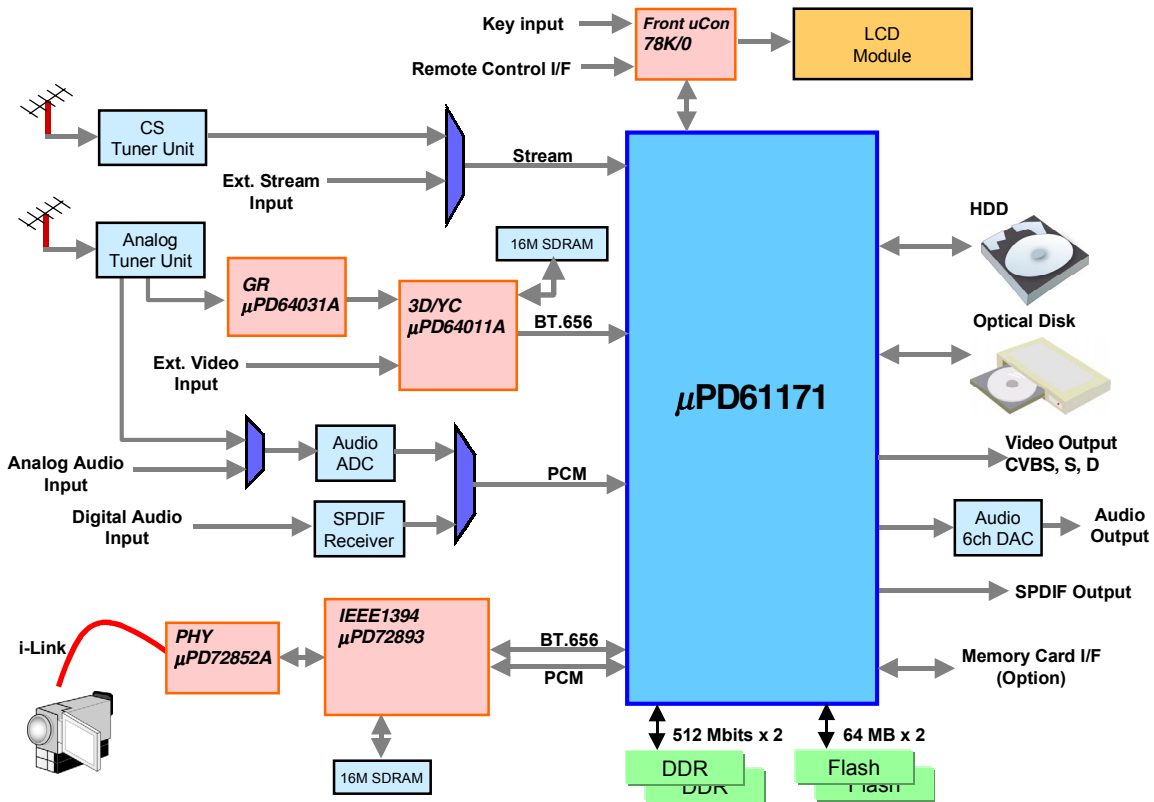

FEATURE LIST

High-performance main processor:

- High-performance MIPS32 CPU core: 225 Dhrystone MIPS @ 187 MHz frequency
- 32-bit RISC MIPS architecture
- Supports MIPS32 instruction set
- 8 KB instruction cache, 8 KB data cache configuration
- EJTAG debugging interface

High-performance sub CPU:

- High-performance MIPS32 CPU core with DSP features for media processing
- 8 KB instruction cache, 8 KB data cache configuration
- 48 KB scratch-pad memory support

Unified memory controller:

- Supports 32-bit bus width DDR SDRAM
- Supports data rate up to PC266
- Unified CPU / MPEG Codec / Graphics memory
- Supports 128 M bits, 256 M bits, 512 M bits DDR SDRAM device
- Total memory size up to 1 G bits

External memory interface (EMI):

- ROM interface
 - Total address area 64 MB/CS for ROM
 - Supports normal, page and flash ROM
 - Supports NOR, NAND and strata flash ROM
 - 2 chip select signals for ROM
- General input/output (GIO) interface
 - Total address area 16 MB for GIO
 - 4 chip select signals for GIO
 - Supports Intel, Motorola, and 16-bit PC card (PCMCIA) interfaces

MPEG video encode engine:

- MPEG2 video MP@ML, SP@ML standard and MPEG1 standard
- Single-pass VBR, CBR encode control
- Supports various picture sizes
 - Horizontal: 720, 704, 640, 544, 480, 352, 320 pixels/line
 - Vertical: 480, 240, 576, 288 lines/frame
- Pre-analysis: Film detection, scene change detection and motion estimation assist
- Supports video
 - 8-bit Y/Cb/Cr 4:2:2 (ITU-R BT.656)
- Time base corrector
- Embedded 32-bit RISC encode control processor

Audio encode engine:

- MPEG1 audio layer 2 standard
- LPCM for DVD/D-VHS
- Supports sample rate conversion
- Dolby Digital consumer encode (family option)

MPEG stream processor:

- MPEG2-PS, MPEG2-TS and MPEG1-System demultiplexing
- Supports DVD-Video, DVD-Video recording and VCD
- Integrated CSS and CPPM decryption
- Integrated CPRM and DES for encryption / decryption
- Integrated Multi-2 and DVB descrambler
- Multiplex support for format conversion
- Demultiplex support
- Partial TS generation
- Stream interfaces
 - Two 8-bit parallel ports
 - Two serial ports

MPEG video decode engine:

- MPEG2 video MP@ML, SP@ML standard and MPEG1 standard
- Supports double decode capability for trick play
- JPEG decode accelerator

Audio decode engine:

- MPEG1 audio layer 1/2 standard
- LPCM for DVD/D-VHS
- Dolby Digital 5.1 channel decode (family option)
- DTS (family option)
- MP3 (family option)
- WMA (family option)
- Supports virtual surround
- Supports mixing of test tone, attenuation

Display/graphics BitBlit engine:

- 7 graphics planes
- 256-level alpha blending between all planes
- Simultaneous interlace and progressive video output
- Motion adaptive 3D-NR and motion adaptive De-interlacer
- Clipping functions for OSD
- Color space and color depth conversion function
- Two independent real-time scalars plus offline scalars for both OSD planes
- Sub-picture decoding and scaling functions

Video encoder:

- Six 54 MHz 10-bit DACs for analog YPbPr (or YCbCr or RGB), S-Video (Y/C) and CVBS video output.
- NTSC, PAL and SECAM standards
- Support for L21 data, Teletext, WSS, VBID, and VPS

External audio/video port:

- 1 video/stereo audio input port for MPEG2 audio/video encode engine
- 1 video/stereo audio I/O port for external DV codec device
- 1 video output port for external video encoder device
- Multi-channel output port for audio DAC device
- IEC60958 output port
- Supported video formats:
 - ITU-R BT.656
 - ITU-R BT.1358

PCI interface:

- 3.3 V 33 MHz 32-bit PCI 2.2
- Initiator/Target
- 2 target windows
- Boot across PCI

IDE interface:

- Supports two IDE interfaces for up to four IDE drives
- UATA100/66/33, bus master IDE and PIO modes
- 2 IDE I/F Supports

Peripherals:

- Supports one MultiMediaCard™/Secure Digital Memory Card interface
- Supports one Memory Stick™ interface
- Two 16550 UARTs with 16-byte FIFOs
- Two asynchronous UARTs
- Supports one clocked serial interface (CSI)
- Two ISO-7816-compliant SmartCard interfaces
- Two I²C-compatible multi-master interfaces
- General purpose I/O
- Four timers supporting input capture/output compare
- Two system timers, an elapse timer, a (volatile) real-time clock and a watch-dog timer

Physical:

- Power : 2.5 W (TYP)
- Power supply voltage : 3.3 V I/O
 - 2.5 V I/O for DDR SDRAM interface
 - 1.5 V for core logic

Package:

- 449-pin Plastic BGA (27 × 27 mm)

1. FUNCTIONAL DESCRIPTION

1.1 Overview

The functionality of the device can be divided into the following areas:

- CPU core
- MPEG AV encoder
- MPEG stream processor
- MPEG video decoder
- MPEG audio decoder/processor
- External A/V input/output
- Graphics processor
- Video encoder
- Miscellaneous interfaces

1.2 Block Diagram

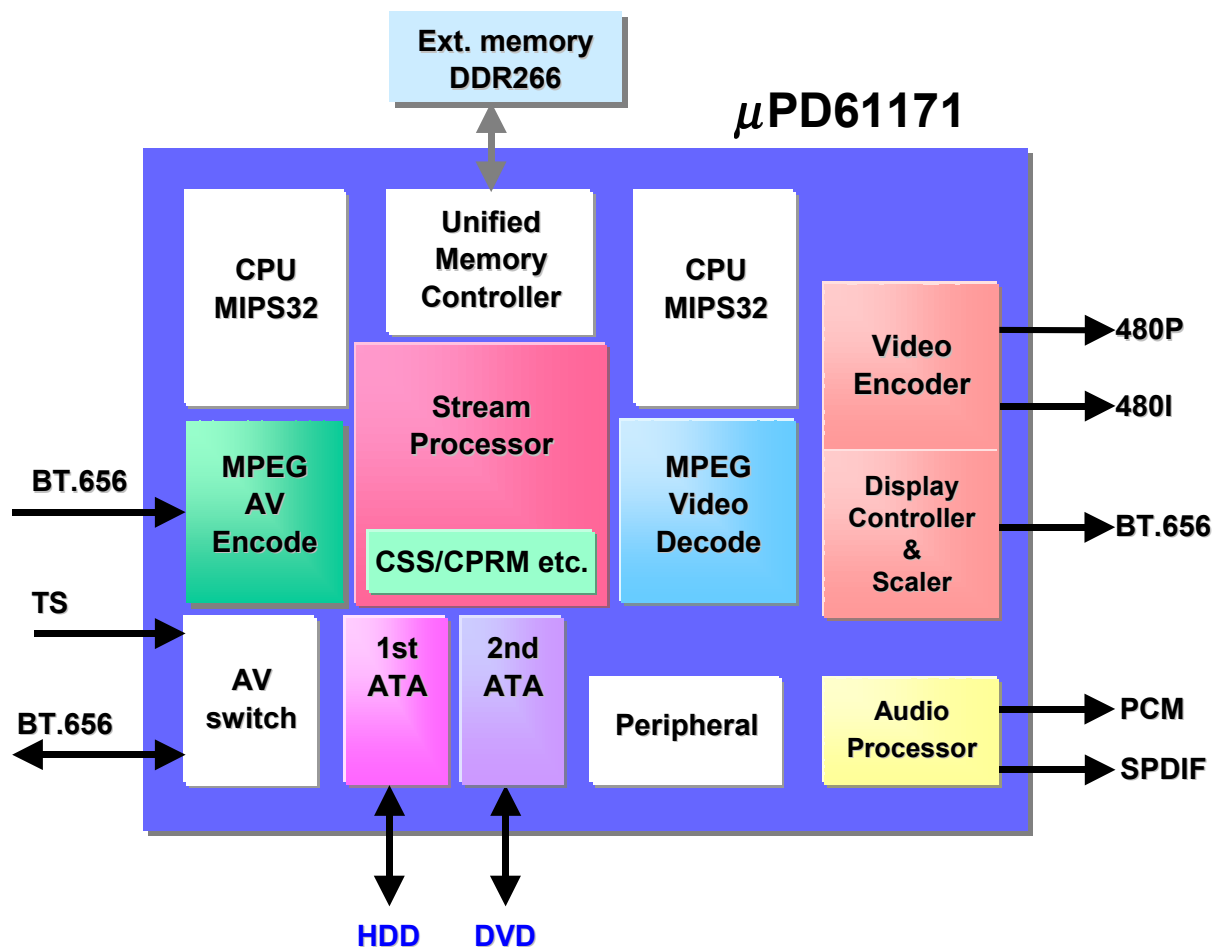

2. PACKAGE DRAWING

449-PIN PLASTIC BGA (27x27)

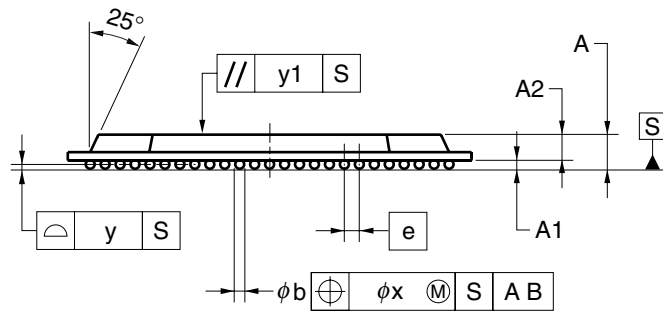
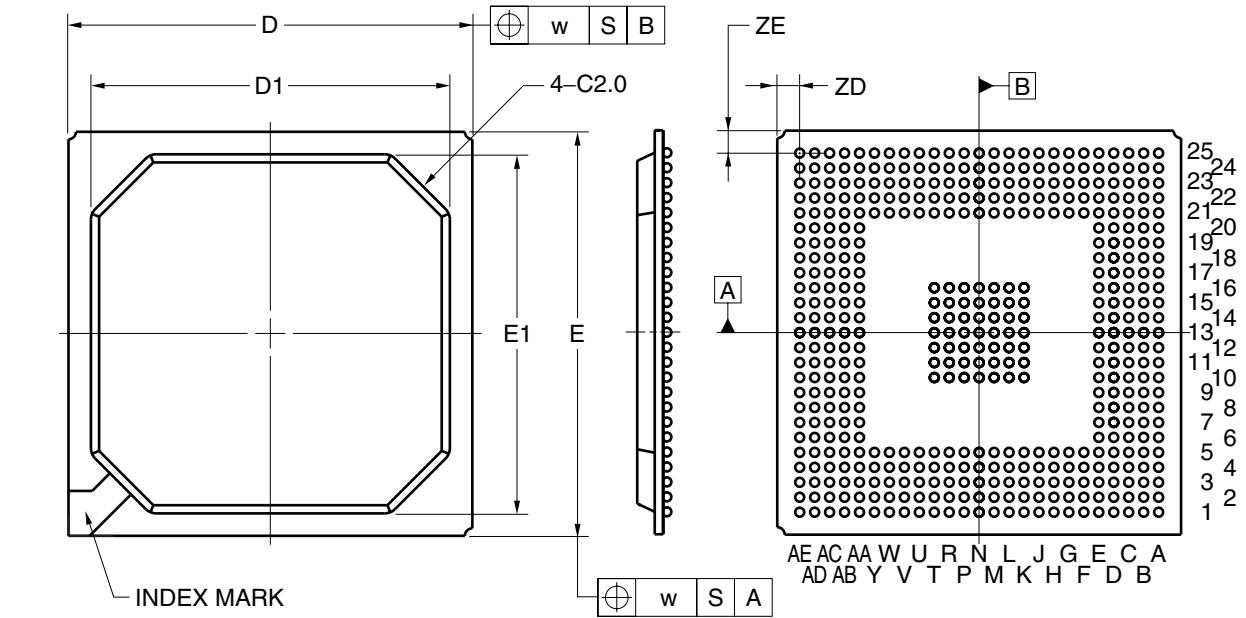

ITEM	MILLIMETERS
D	27.00±0.20
D1	24.00
E	27.00±0.20
E1	24.00
w	0.30
Ⓜ	1.00
A	2.23±0.30
A1	0.50±0.10
A2	1.73
b	0.60±0.10
x	0.15
y	0.15
y1	0.35
ZD	1.50
ZE	1.50

P449F1-100-MN2-1

Dolby and Dolby Digital are trademarks of Dolby Laboratories Corporation.

MIPS32 and MIPS are trademarks of MIPS Technologies Corporation.

DTS is a trademark of Digital Theater Systems, Inc.

MultiMediaCard is a trademark of Infineon Technologies AG of Germany.

Memory Stick is a trademark of Sony corporation.

The names of other companies and products are trademarks or registered trademarks of each company.

- **The information contained in this document is being issued in advance of the production cycle for the product. The parameters for the product may change before final production or NEC Electronics Corporation, at its own discretion, may withdraw the product prior to its production.**
- No part of this document may be copied or reproduced in any form or by any means without the prior written consent of NEC Electronics. NEC Electronics assumes no responsibility for any errors that may appear in this document.
- NEC Electronics does not assume any liability for infringement of patents, copyrights or other intellectual property rights of third parties by or arising from the use of NEC Electronics products listed in this document or any other liability arising from the use of such products. No license, express, implied or otherwise, is granted under any patents, copyrights or other intellectual property rights of NEC Electronics or others.
- Descriptions of circuits, software and other related information in this document are provided for illustrative purposes in semiconductor product operation and application examples. The incorporation of these circuits, software and information in the design of a customer's equipment shall be done under the full responsibility of the customer. NEC Electronics assumes no responsibility for any losses incurred by customers or third parties arising from the use of these circuits, software and information.
- While NEC Electronics endeavors to enhance the quality, reliability and safety of NEC Electronics products, customers agree and acknowledge that the possibility of defects thereof cannot be eliminated entirely. To minimize risks of damage to property or injury (including death) to persons arising from defects in NEC Electronics products, customers must incorporate sufficient safety measures in their design, such as redundancy, fire-containment and anti-failure features.
- NEC Electronics products are classified into the following three quality grades: "Standard", "Special", and "Specific". The "Specific" quality grade applies only to NEC Electronics products developed based on a customer-designated "quality assurance program" for a specific application. The recommended applications of an NEC Electronics product depend on its quality grade, as indicated below. Customers must check the quality grade of each NEC Electronics products before using it in a particular application.
 - "Standard": Computers, office equipment, communications equipment, test and measurement equipment, audio and visual equipment, home electronic appliances, machine tools, personal electronic equipment and industrial robots.
 - "Special": Transportation equipment (automobiles, trains, ships, etc.), traffic control systems, anti-disaster systems, anti-crime systems, safety equipment and medical equipment (not specifically designed for life support).
 - "Specific": Aircraft, aerospace equipment, submersible repeaters, nuclear reactor control systems, life support systems and medical equipment for life support, etc.

The quality grade of NEC Electronics products is "Standard" unless otherwise expressly specified in NEC Electronics data sheets or data books, etc. If customers wish to use NEC Electronics products in applications not intended by NEC Electronics, they must contact an NEC Electronics sales representative in advance to determine NEC Electronics' willingness to support a given application.

(Note)

- (1) "NEC Electronics" as used in this statement means NEC Electronics Corporation and also includes its majority-owned subsidiaries.
- (2) "NEC Electronics products" means any product developed or manufactured by or for NEC Electronics (as defined above).