



Application Note

V850E/MA1, V850E/MA2, V850E/MA3, V850E/ME2

32-Bit Single-Chip Microcontrollers

PCI Host Bridge Macro

V850E/MA1:	V850E/MA2:	V850E/MA3:	V850E/ME2:
μPD703103A	μPD703108	μPD703131A	μPD703111A
μPD703105A		μPD703131AY	
μPD703106A		μPD703132A	
μPD703106A(A)		μPD703132AY	
μPD703107A		μPD703133A	
μPD703107A(A)		μPD703133AY	
μPD70F3107A		μPD703134A	
μPD70F3107A(A)		μPD703134AY	
		μPD70F3134A	
		μPD70F3134AY	

[MEMO]

www.DataSheet4U.com

NOTES FOR CMOS DEVICES**① VOLTAGE APPLICATION WAVEFORM AT INPUT PIN**

Waveform distortion due to input noise or a reflected wave may cause malfunction. If the input of the CMOS device stays in the area between V_{IL} (MAX) and V_{IH} (MIN) due to noise, etc., the device may malfunction. Take care to prevent chattering noise from entering the device when the input level is fixed, and also in the transition period when the input level passes through the area between V_{IL} (MAX) and V_{IH} (MIN).

② HANDLING OF UNUSED INPUT PINS

Unconnected CMOS device inputs can be cause of malfunction. If an input pin is unconnected, it is possible that an internal input level may be generated due to noise, etc., causing malfunction. CMOS devices behave differently than Bipolar or NMOS devices. Input levels of CMOS devices must be fixed high or low by using pull-up or pull-down circuitry. Each unused pin should be connected to V_{DD} or GND via a resistor if there is a possibility that it will be an output pin. All handling related to unused pins must be judged separately for each device and according to related specifications governing the device.

③ PRECAUTION AGAINST ESD

A strong electric field, when exposed to a MOS device, can cause destruction of the gate oxide and ultimately degrade the device operation. Steps must be taken to stop generation of static electricity as much as possible, and quickly dissipate it when it has occurred. Environmental control must be adequate. When it is dry, a humidifier should be used. It is recommended to avoid using insulators that easily build up static electricity. Semiconductor devices must be stored and transported in an anti-static container, static shielding bag or conductive material. All test and measurement tools including work benches and floors should be grounded. The operator should be grounded using a wrist strap. Semiconductor devices must not be touched with bare hands. Similar precautions need to be taken for PW boards with mounted semiconductor devices.

④ STATUS BEFORE INITIALIZATION

Power-on does not necessarily define the initial status of a MOS device. Immediately after the power source is turned ON, devices with reset functions have not yet been initialized. Hence, power-on does not guarantee output pin levels, I/O settings or contents of registers. A device is not initialized until the reset signal is received. A reset operation must be executed immediately after power-on for devices with reset functions.

⑤ POWER ON/OFF SEQUENCE

In the case of a device that uses different power supplies for the internal operation and external interface, as a rule, switch on the external power supply after switching on the internal power supply. When switching the power supply off, as a rule, switch off the external power supply and then the internal power supply. Use of the reverse power on/off sequences may result in the application of an overvoltage to the internal elements of the device, causing malfunction and degradation of internal elements due to the passage of an abnormal current.

The correct power on/off sequence must be judged separately for each device and according to related specifications governing the device.

⑥ INPUT OF SIGNAL DURING POWER OFF STATE

Do not input signals or an I/O pull-up power supply while the device is not powered. The current injection that results from input of such a signal or I/O pull-up power supply may cause malfunction and the abnormal current that passes in the device at this time may cause degradation of internal elements. Input of signals during the power off state must be judged separately for each device and according to related specifications governing the device.

The copyright of the PCI host bridge macro described in this document is held by the System Interface Module Development Department, Device Solutions Division, NEC Engineering, Ltd.
Green Hills Software and MULTI are trademarks of Green Hills Software, Inc.

These commodities, technology or software, must be exported in accordance with the export administration regulations of the exporting country.
Diversion contrary to the law of that country is prohibited.

- **The information in this document is current as of March, 2004. The information is subject to change without notice. For actual design-in, refer to the latest publications of NEC Electronics data sheets or data books, etc., for the most up-to-date specifications of NEC Electronics products. Not all products and/or types are available in every country. Please check with an NEC Electronics sales representative for availability and additional information.**

- No part of this document may be copied or reproduced in any form or by any means without the prior written consent of NEC Electronics. NEC Electronics assumes no responsibility for any errors that may appear in this document.
- NEC Electronics does not assume any liability for infringement of patents, copyrights or other intellectual property rights of third parties by or arising from the use of NEC Electronics products listed in this document or any other liability arising from the use of such products. No license, express, implied or otherwise, is granted under any patents, copyrights or other intellectual property rights of NEC Electronics or others.
- Descriptions of circuits, software and other related information in this document are provided for illustrative purposes in semiconductor product operation and application examples. The incorporation of these circuits, software and information in the design of a customer's equipment shall be done under the full responsibility of the customer. NEC Electronics assumes no responsibility for any losses incurred by customers or third parties arising from the use of these circuits, software and information.
- While NEC Electronics endeavors to enhance the quality, reliability and safety of NEC Electronics products, customers agree and acknowledge that the possibility of defects thereof cannot be eliminated entirely. To minimize risks of damage to property or injury (including death) to persons arising from defects in NEC Electronics products, customers must incorporate sufficient safety measures in their design, such as redundancy, fire-containment and anti-failure features.
- NEC Electronics products are classified into the following three quality grades: "Standard", "Special" and "Specific".

The "Specific" quality grade applies only to NEC Electronics products developed based on a customer-designated "quality assurance program" for a specific application. The recommended applications of an NEC Electronics product depend on its quality grade, as indicated below. Customers must check the quality grade of each NEC Electronics product before using it in a particular application.

"Standard": Computers, office equipment, communications equipment, test and measurement equipment, audio and visual equipment, home electronic appliances, machine tools, personal electronic equipment and industrial robots.

"Special": Transportation equipment (automobiles, trains, ships, etc.), traffic control systems, anti-disaster systems, anti-crime systems, safety equipment and medical equipment (not specifically designed for life support).

"Specific": Aircraft, aerospace equipment, submersible repeaters, nuclear reactor control systems, life support systems and medical equipment for life support, etc.

The quality grade of NEC Electronics products is "Standard" unless otherwise expressly specified in NEC Electronics data sheets or data books, etc. If customers wish to use NEC Electronics products in applications not intended by NEC Electronics, they must contact an NEC Electronics sales representative in advance to determine NEC Electronics' willingness to support a given application.

(Note)

- (1) "NEC Electronics" as used in this statement means NEC Electronics Corporation and also includes its majority-owned subsidiaries.
- (2) "NEC Electronics products" means any product developed or manufactured by or for NEC Electronics (as defined above).

Regional Information

Some information contained in this document may vary from country to country. Before using any NEC Electronics product in your application, please contact the NEC Electronics office in your country to obtain a list of authorized representatives and distributors. They will verify:

- Device availability
- Ordering information
- Product release schedule
- Availability of related technical literature
- Development environment specifications (for example, specifications for third-party tools and components, host computers, power plugs, AC supply voltages, and so forth)
- Network requirements

In addition, trademarks, registered trademarks, export restrictions, and other legal issues may also vary from country to country.

[GLOBAL SUPPORT]

<http://www.necel.com/en/support/support.html>

NEC Electronics America, Inc. (U.S.)
Santa Clara, California
Tel: 408-588-6000
800-366-9782

NEC Electronics (Europe) GmbH
Duesseldorf, Germany
Tel: 0211-65030

NEC Electronics Hong Kong Ltd.
Hong Kong
Tel: 2886-9318

- **Sucursal en España**
Madrid, Spain
Tel: 091-504 27 87

NEC Electronics Hong Kong Ltd.
Seoul Branch
Seoul, Korea
Tel: 02-558-3737

- **Succursale Française**
Vélizy-Villacoublay, France
Tel: 01-30-67 58 00

NEC Electronics Shanghai Ltd.
Shanghai, P.R. China
Tel: 021-5888-5400

- **Filiale Italiana**
Milano, Italy
Tel: 02-66 75 41

NEC Electronics Taiwan Ltd.
Taipei, Taiwan
Tel: 02-2719-2377

- **Branch The Netherlands**
Eindhoven, The Netherlands
Tel: 040-244 58 45

NEC Electronics Singapore Pte. Ltd.
Novena Square, Singapore
Tel: 6253-8311

- **Tyskland Filial**
Taebby, Sweden
Tel: 08-63 80 820

- **United Kingdom Branch**
Milton Keynes, UK
Tel: 01908-691-133

INTRODUCTION

Readers This application note is intended for users who wish to understand the functions of the V850E/MA1, V850E/MA2, V850E/MA3, V850E/ME2, and PCI bus to design application systems using these products.

Purpose The purpose of this application note is to help the user understand the PCI host bridge macro and its composition using the V850E/MA1, V850E/MA2, V850E/MA3, V850E/ME2, and PCI host bridge macro as a system example.

Organization This application note is broadly divided into the following sections.

- Overview of each product
- Overview of PCI host bridge macro
- Specifications of PCI host bridge macro
- Configuration examples of FPGA integration
- Application examples

How to Read This Manual It is assumed that the readers of this application note have general knowledge in the fields of electrical engineering, logic circuits, and microcontrollers.

For details of the hardware functions and electrical specifications of the V850E/MA1, V850E/MA2, V850E/MA3, and V850E/ME2

→ Refer to the **Hardware User's Manual** of each product.

For details of the instruction functions of the V850E/MA1, V850E/MA2, V850E/MA3, and V850E/ME2

→ Refer to the **V850E1 Architecture User's Manual**.

Conventions

Data significance: Higher digits on the left and lower digits on the right

Active low representation: $\overline{\text{xxx}}$ (overscore over pin or signal name) or /xxx ("n" before signal name)

Memory map address: Higher addresses on the top and lower addresses on the bottom

Note: Footnote for item marked with **Note** in the text

Caution: Information requiring particular attention

Remark: Supplementary information

Numeric representation: Binary ... xxxx or xxxxB

Decimal ... xxxx

Hexadecimal ... xxxxH

Prefix indicating power of 2 (address space, memory capacity):

K (kilo) ... $2^{10} = 1,024$

M (mega) ... $2^{20} = 1,024^2$

G (giga) ... $2^{30} = 1,024^3$

Related Documents

The related documents indicated in this publication may include preliminary versions. However, preliminary versions are not marked as such.

Documents related to V850E/MA1, V850E/MA2, V850E/MA3, and V850E/ME2

Document Name	Document No.
V850E1 Architecture User's Manual	U14559E
V850E/MA1 Hardware User's Manual	U14359E
V850E/MA1 Hardware Application Note	U15179E
V850E/MA2 Hardware User's Manual	U14980E
V850E/MA3 Hardware User's Manual	U16397E
V850E/ME2 Hardware User's Manual	U16031E
V850E/ME2 Hardware Application Note	U16794E
V850E/ME2 USB Function Driver Application Note	U17069E
V850E/MA1, V850E/MA2, V850E/MA3, V850E/ME2 PCI Host Bridge Macro Application Note	This manual

Documents related to development tools (user's manuals)

Document Name	Document No.	
IE-V850E-MC, IE-V850E-MC-A In-Circuit Emulator	U14487E	
IE-703107-MC-EM1 In-Circuit Emulator Option Board	U14481E	
IE-V850E1-CD-NW PCMCIA Card Type On-Chip Debug Emulator	U16647E	
CA850 Ver.2.50 C Compiler Package	Operation	U16053E
	C Language	U16054E
	Assembly Language	U16042E
PM plus Ver.5.20	U16934E	
ID850 Ver.2.50 Integrated Debugger	Operation	U16217E
ID850NW Ver.2.51 Integrated Debugger	Operation	U16454E
SM850 Ver.2.40 System Simulator	Operation	U15182E
SM850 Ver.2.00 or Later System Simulator	External Part User Open Interface Specifications	U14873E
RX850 Ver.3.13 or Later Real-Time OS	Basics	U13430E
	Installation	U13410E
	Technical	U13431E
RX850 Pro Ver.3.15 Real-Time OS	Basics	U13773E
	Installation	U13774E
	Technical	U13772E
RD850 Ver.3.01 Task Debugger	U13737E	
RD850 Pro Ver.3.01 Task Debugger	U13916E	
AZ850 Ver.3.10 System Performance Analyzer	U14410E	
PG-FP4 Flash Memory Programmer	U15260E	

CONTENTS

CHAPTER 1 OVERVIEW OF EACH PRODUCT.....	10
1.1 Outline	10
1.2 Features.....	11
1.3 Ordering Information.....	12
1.4 Pin Configuration.....	14
1.5 Internal Block Diagram	25
CHAPTER 2 OVERVIEW OF PCI HOST BRIDGE MACRO.....	29
2.1 Outline	29
2.2 Features.....	30
CHAPTER 3 SPECIFICATIONS OF PCI HOST BRIDGE MACRO.....	31
3.1 Internal Blocks of PCI Host Bridge Macro	31
3.2 Relationship Between Internal Blocks and Signals.....	32
3.3 Pin Functions	33
3.3.1 External bus slave interface pins	33
3.3.2 SDRAM bus interface pins	33
3.3.3 PCI bus interface pins	34
3.4 Registers	35
3.4.1 PCI_CONFIG_DATA register.....	35
3.4.2 PCI_CONFIG_ADD register.....	36
3.4.3 PCI_CONTROL register.....	37
3.4.4 PCI_IO_BASE register.....	38
3.4.5 PCI_MEM_BASE register	38
3.4.6 PCI_INT_CTL register.....	39
3.4.7 PCI_ERR_ADD register	40
3.4.8 SYSTEM_MEM_BASE register	41
3.4.9 SYSTEM_MEM_RANGE register	41
3.4.10 SDRAM_CTL register	42
3.5 Address Map	44
3.6 Initializing PCI Host Bridge Macro	45
3.7 Bus Width of External Bus Interface	46
3.8 Timing.....	47
3.8.1 External bus interface timing.....	47
3.8.2 PCI bus interface timing.....	50
CHAPTER 4 CONFIGURATION EXAMPLES OF FPGA INTEGRATION.....	57
4.1 Conditions for Configuration Examples of FPGA Integration	57
4.2 Points to Remember When Creating Top Layer of FPGA	57
4.3 Reference Diagram for FPGA Top Connection	58
4.4 FPGA Top Pin Functions	59
4.4.1 CPU bus slave interface pins.....	59
4.4.2 SDRAM bus interface pins	59
4.4.3 PCI bus interface pins	60
4.5 FPGA Top Pin Configuration.....	61

4.5.1	Internal connection diagram of external bus interface	61
4.5.2	Internal connection diagram of PCI bus interface	62
4.5.3	External connection diagram of external bus interface (example of connection with V850E/ME2)....	63
4.5.4	External connection diagram of PCI bus interface	64
4.6	Cautions on Designing FPGA	65
4.6.1	FPGA fitting design	65
4.6.2	PCI bus interface timing parameters (as constraint of PCI CLK = 33 MHz).....	65
4.6.3	SDRAM interface timing	66
CHAPTER 5	APPLICATION EXAMPLES.....	67
5.1	Block Diagram of Evaluation Board	67
5.2	Specifications of Evaluation Board	68
5.3	Example of Evaluation Board Connection Circuit	69
5.4	Evaluation Board Memory Space	70
5.5	Sample Program Examples	72
5.5.1	Development tools	72
5.5.2	Program configuration	72
5.5.3	V850E/ME2 PCI host bridge macro initialization sample program list	73
5.5.4	PCI configuration space access sample program list	76
5.5.5	IDE HDD access sample program list.....	79

CHAPTER 1 OVERVIEW OF EACH PRODUCT

The V850E/MA1, V850E/MA2, V850E/MA3, and V850E/ME2 are products in NEC Electronics' V850 Series of single-chip microcontrollers. This chapter gives a simple outline of each product.

1.1 Outline

The V850E/MA1, V850E/MA2, V850E/MA3, and V850E/ME2 are 32-bit single-chip microcontrollers that integrate the V850E1 CPU, which is a 32-bit RISC-type CPU core for ASIC, newly developed as the CPU core central to system LSI in the current age of system-on-chip. These devices incorporate memory and various peripheral functions such as memory controllers, a DMA controller, timer/counters, serial interfaces, and an A/D converter for realizing high-capacity data processing and sophisticated real-time control.

1.2 Features

Commercial Name		V850E/MA1				V850E/MA2				V850E/MA3				V850E/ME2	
Maximum operating frequency		50 MHz				40 MHz				80 MHz				150 MHz	
Internal memory (KB)	Mask ROM	–	128	256	–	–				256	512	–	–		
	Flash memory	–			256	–				–			512	–	
	RAM	4	10			4				16	32	16	32	Instruction RAM: 128 Data RAM: 16	
Cache (KB)		–				–				–				Instruction cache: 8	
External bus	Bus type	Separate				Separate				Separate/multiplexed				Separate	
	Address bus	26 bits				25 bits				26 bits				26 bits	
	Data bus	8/16 bits				8/16 bits				8/16 bits				16/32 bits	
	Chip select signals	8				4				8				8	
Memory controller		SDRAM, EDO DRAM, SRAM, etc.				SDRAM, SRAM, etc.									
Interrupts	External ^{Note 1}	17 (17)				4 (4)				26 (26)				40 (31)	
	Internal	41				27				49				59	
DSP function	32 × 32 → 64	20 to 40 ns (50 MHz)				25 to 50 ns (40 MHz)				12.5 to 25 ns (80 MHz)				6.7 to 13.3 ns (150 MHz)	
	32 × 32 + 32 → 32	60 ns (50 MHz)				75 ns (40 MHz)				37.5 ns (80 MHz)				20 ns (150 MHz)	
16-bit timer	TMC	4 ch				2 ch				–				6 ch	
	TMP	–				–				3 ch				–	
	TMQ	–				–				1 ch				–	
	Interval timer	4 ch				4 ch				4 ch				4 ch	
	Up/down counter	–				–				1 ch				2 ch	
Watchdog timer		–				–				1 ch				–	
Serial interface	CSI	1 ch				–				–				1 ch	
	UART	1 ch				–				–				1 ch	
	CSI/UART	2 ch				2 ch				3 ch				1 ch	
	UART/I ² C	–				–				1 ch ^{Note 2}				–	
10-bit A/D converter		8 ch				4 ch				8 ch				8 ch	
8-bit D/A converter		–				–				2 ch				–	
DMA controller		4 ch				4 ch				4 ch				4 ch	
Ports	CMOS input	9				5				11				7	
	CMOS I/O	106				74				101				77	
Debug functions		–				–				Provided (RUN, break)				Provided (RUN, break, trace)	
Other peripheral functions		PWM × 2 ch				–				ROM correction function				USB function, SSCG, PWM × 2 ch	
Power supply voltage		3.0 to 3.6 V								2.3 to 2.7 V (internal) 3.0 to 3.6 V (external)				1.5 V (internal) 3.3 V (external)	
Power consumption (mask version TYP.)		528 mW				416 mW				575 mW				200 mW	
Package		144-pin LQFP (20 × 20) 161-pin FBGA (13 × 13)				100-pin LQFP (14 × 14)				144-pin LQFP (20 × 20) 161-pin FBGA (13 × 13)				176-pin LQFP (20 × 20) 240-pin FBGA (16 × 16)	
Operating ambient temperature		T _A = –40 to +85°C										T _A = –40 to +85°C (@133 MHz) T _A = –40 to +70°C (@150 MHz)			

Notes 1. The figure in parentheses indicates the number of external interrupts that can release STOP mode.

2. Available only in on-chip I²C products (Y products).

1.3 Ordering Information

(1) V850E/MA1

Part Number	Package	Internal ROM
μ PD703103AGJ-UEN	144-pin plastic LQFP (fine pitch) (20 × 20)	ROMless
μ PD703105AGJ-xxx-UEN	144-pin plastic LQFP (fine pitch) (20 × 20)	Mask ROM (128 KB)
μ PD703106AGJ-xxx-UEN	144-pin plastic LQFP (fine pitch) (20 × 20)	Mask ROM (128 KB)
μ PD703106AGJ(A)-xxx-UEN	144-pin plastic LQFP (fine pitch) (20 × 20)	Mask ROM (128 KB)
μ PD703106AF1-xxx-EN4	161-pin plastic FBGA (13 × 13)	Mask ROM (128 KB)
μ PD703107AGJ-xxx-UEN	144-pin plastic LQFP (fine pitch) (20 × 20)	Mask ROM (256 KB)
μ PD703107AGJ(A)-xxx-UEN	144-pin plastic LQFP (fine pitch) (20 × 20)	Mask ROM (256 KB)
μ PD703107AF1-xxx-EN4	161-pin plastic FBGA (13 × 13)	Mask ROM (256 KB)
μ PD70F3107AGJ-UEN	144-pin plastic LQFP (fine pitch) (20 × 20)	Flash memory (512 KB)
μ PD70F3107AGJ(A)-UEN	144-pin plastic LQFP (fine pitch) (20 × 20)	Flash memory (512 KB)
μ PD70F3107AF1-EN4	161-pin plastic FBGA (13 × 13)	Flash memory (512 KB)

(2) V850E/MA2

Part Number	Package	Internal ROM
μ PD703108GC-8EU	100-pin plastic LQFP (fine pitch) (14 × 14)	ROMless

(3) V850E/MA3

Part Number	Package	Internal ROM
μ PD703131AGJ-xxx-UEN	144-pin plastic LQFP (fine pitch) (20 × 20)	Mask ROM (256 KB)
μ PD703131AF1-xxx-EN4	161-pin plastic FBGA (13 × 13)	Mask ROM (256 KB)
μ PD703131AYGJ-xxx-UEN	144-pin plastic LQFP (fine pitch) (20 × 20)	Mask ROM (256 KB)
μ PD703131AYF1-xxx-EN4	161-pin plastic FBGA (13 × 13)	Mask ROM (256 KB)
μ PD703132AGJ-xxx-UEN	144-pin plastic LQFP (fine pitch) (20 × 20)	Mask ROM (256 KB)
μ PD703132AF1-xxx-EN4	161-pin plastic FBGA (13 × 13)	Mask ROM (256 KB)
μ PD703132AYGJ-xxx-UEN	144-pin plastic LQFP (fine pitch) (20 × 20)	Mask ROM (256 KB)
μ PD703132AYF1-xxx-EN4	161-pin plastic FBGA (13 × 13)	Mask ROM (256 KB)
μ PD703133AGJ-xxx-UEN	144-pin plastic LQFP (fine pitch) (20 × 20)	Mask ROM (512 KB)
μ PD703133AF1-xxx-EN4	161-pin plastic FBGA (13 × 13)	Mask ROM (512 KB)
μ PD703133AYGJ-xxx-UEN	144-pin plastic LQFP (fine pitch) (20 × 20)	Mask ROM (512 KB)
μ PD703133AYF1-xxx-EN4	161-pin plastic FBGA (13 × 13)	Mask ROM (512 KB)
μ PD703134AGJ-xxx-UEN	144-pin plastic LQFP (fine pitch) (20 × 20)	Mask ROM (512 KB)
μ PD703134AF1-xxx-EN4	161-pin plastic FBGA (13 × 13)	Mask ROM (512 KB)
μ PD703134AYGJ-xxx-UEN	144-pin plastic LQFP (fine pitch) (20 × 20)	Mask ROM (512 KB)
μ PD703134AYF1-xxx-EN4	161-pin plastic FBGA (13 × 13)	Mask ROM (512 KB)
μ PD70F3134AGJ-UEN	144-pin plastic LQFP (fine pitch) (20 × 20)	Flash memory (512 KB)
μ PD70F3134AF1-EN4	161-pin plastic FBGA (13 × 13)	Flash memory (512 KB)
μ PD70F3134AYGJ-UEN	144-pin plastic LQFP (fine pitch) (20 × 20)	Flash memory (512 KB)
μ PD70F3134AYF1-EN4	161-pin plastic FBGA (13 × 13)	Flash memory (512 KB)

(4) V850E/ME2

Part Number	Package	Maximum Operating Frequency
μ PD703111AGM-10-UEU	176-pin plastic LQFP (fine pitch) (24 × 24)	100 MHz
μ PD703111AGM-13-UEU	176-pin plastic LQFP (fine pitch) (24 × 24)	133 MHz
μ PD703111AGM-15-UEU	176-pin plastic LQFP (fine pitch) (24 × 24)	150 MHz
μ PD703111AF1-10-GA3	240-pin plastic FBGA (16 × 16)	100 MHz
μ PD703111AF1-13-GA3	240-pin plastic FBGA (16 × 16)	133 MHz
μ PD703111AF1-15-GA3	240-pin plastic FBGA (16 × 16)	150 MHz

1.4 Pin Configuration

(1) V850E/MA1

- 144-pin plastic LQFP (fine pitch) (20 × 20)

μ PD703103AGJ-UEN	μ PD703106AGJ(A)-xxx-UEN	μ PD70F3107AGJ-UEN
μ PD703105AGJ-xxx-UEN	μ PD703107AGJ-xxx-UEN	μ PD70F3107AGJ(A)-UEN
μ PD703106AGJ-xxx-UEN	μ PD703107AGJ(A)-xxx-UEN	

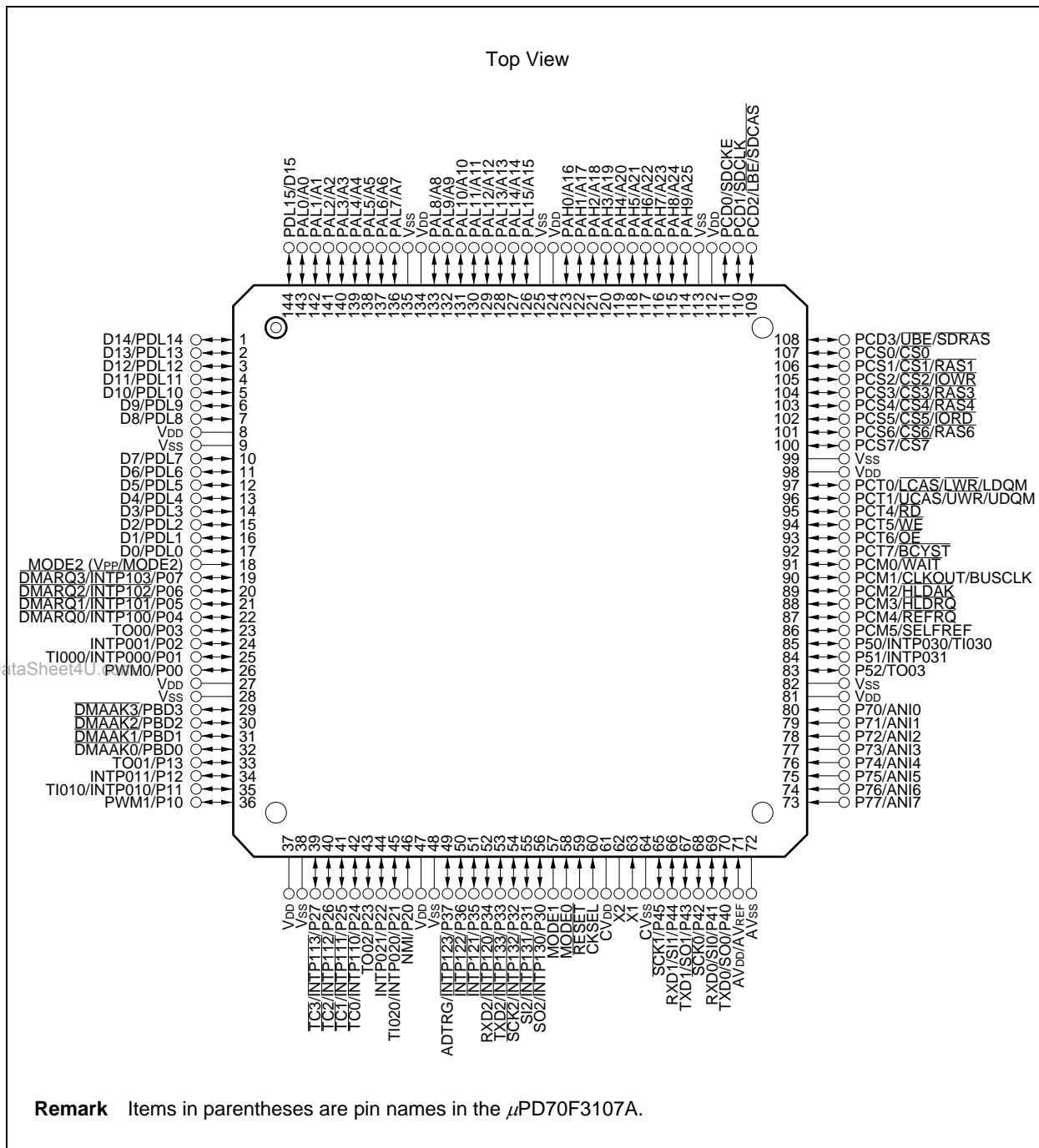

- 161-pin plastic FBGA (13 × 13)
 μ PD703106AF1-xxx-EN4
 μ PD703107AF1-xxx-EN4
 μ PD70F3107AF1-EN4

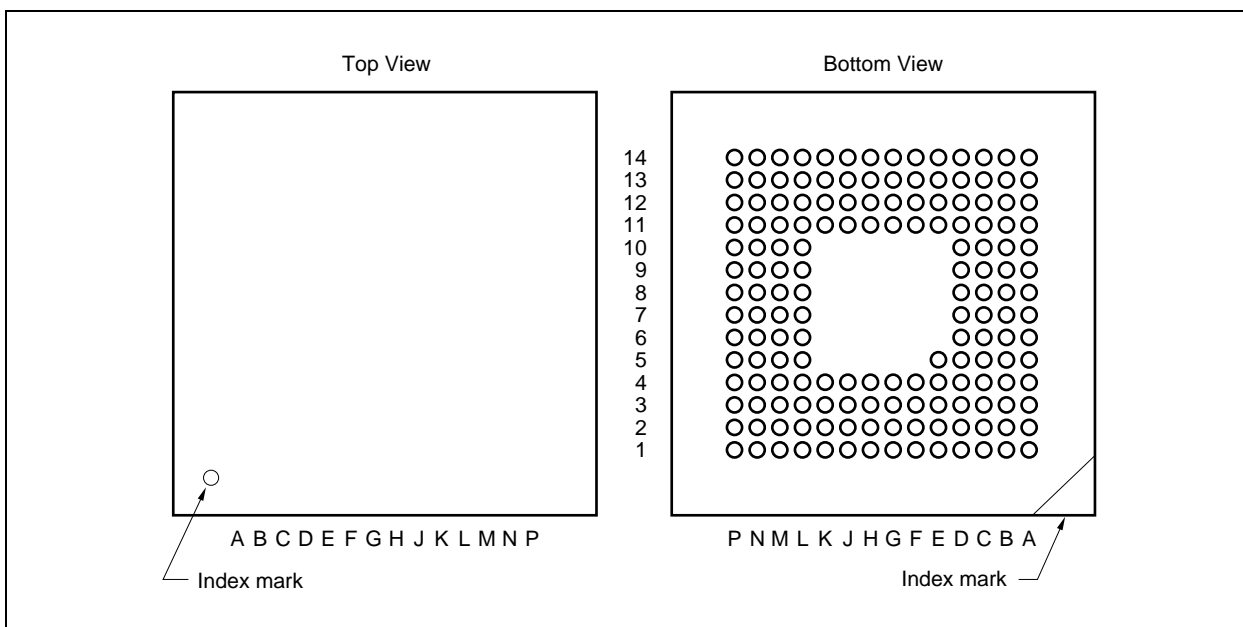

(1/2)

Pin No.	Name	Pin No.	Name	Pin No.	Name
A1	–	B9	A18/PAH2	D3	D14/PDL14
A2	D15/PDL15	B10	A21/PAH5	D4	A3/PAL3
A3	A2/PAL2	B11	A25/PAH9	D5	A6/PAL6
A4	A5/PAL5	B12	SDCLK/PCD1	D6	A10/PAL10
A5	–	B13	$\overline{\text{CS}}1/\text{RAS}1/\text{PCS}1$	D7	A14/PAL14
A6	A9/PAL9	B14	–	D8	A16/PAH0
A7	A12/PAL12	C1	–	D9	A20/PAH4
A8	A15/PAL15	C2	D9/PDL9	D10	A23/PAH7
A9	A17/PAH1	C3	D13/PDL13	D11	SDCKE/PCD0
A10	–	C4	A1/PAL1	D12	$\overline{\text{CS}}0/\text{PCS}0$
A11	A24/PAH8	C5	A7/PAL7	D13	$\overline{\text{CS}}5/\text{IORD}/\text{PCS}5$
A12	V _{DD}	C6	V _{DD}	D14	–
A13	$\overline{\text{LBE}}/\text{SDCAS}/\text{PCD}2$	C7	A11/PAL11	E1	D5/PDL5
A14	$\overline{\text{UBE}}/\text{SDRAS}/\text{PCD}3$	C8	V _{DD}	E2	D7/PDL7
B1	–	C9	A19/PAH3	E3	D8/PDL8
B2	D12/PDL12	C10	A22/PAH6	E4	D11/PDL11
B3	A0/PAL0	C11	V _{SS}	E5	–
B4	A4/PAL4	C12	$\overline{\text{CS}}3/\text{RAS}3/\text{PCS}3$	E11	$\overline{\text{CS}}6/\text{RAS}6/\text{PCS}6$
B5	V _{SS}	C13	$\overline{\text{CS}}2/\text{IOWR}/\text{PCS}2$	E12	$\overline{\text{CS}}4/\text{RAS}4/\text{PCS}4$
B6	A8/PAL8	C14	–	E13	$\overline{\text{CS}}7/\text{PCS}7$
B7	A13/PAL13	D1	V _{SS}	E14	V _{SS}
B8	V _{SS}	D2	D10/PDL10	F1	D2/PDL2

(2/2)

Pin No.	Name	Pin No.	Name	Pin No.	Name
F2	D3/PDL3	K2	V _{SS}	M12	ANI6/P76
F3	D4/PDL4	K3	$\overline{\text{DMAAK1/PBD1}}$	M13	ANI5/P75
F4	V _{DD}	K4	$\overline{\text{DMAAK3/PBD3}}$	M14	–
F11	$\overline{\text{RD/PCT4}}$	K11	ANI1/P71	N1	–
F12	V _{DD}	K12	ANI0/P70	N2	PWM1/P10
F13	$\overline{\text{LCAS/LWR/LDQM/PCT0}}$	K13	V _{SS}	N3	$\overline{\text{TC3/INTP113/P27}}$
F14	$\overline{\text{UCAS/UWR/UDQM/PCT1}}$	K14	V _{DD}	N4	$\overline{\text{TC0/INTP110/P24}}$
G1	MODE2 (MODE2/V _{PP})	L1	–	N5	NMI/P20
G2	$\overline{\text{DMARQ3/INTP103/P07}}$	L2	$\overline{\text{DMAAK2/PBD2}}$	N6	$\overline{\text{ADTRG/INTP123/P37}}$
G3	D0/PDL0	L3	TI010/INTP010/P11	N7	$\overline{\text{TXD2/INTP133/P33}}$
G4	D6/PDL6	L4	$\overline{\text{DMAAK0/PBD0}}$	N8	$\overline{\text{SO2/INTP130/P30}}$
G11	$\overline{\text{WAIT/PCM0}}$	L5	TO02/P23	N9	X2
G12	$\overline{\text{WE/PCT5}}$	L6	V _{DD}	N10	CV _{SS}
G13	$\overline{\text{BCYST/PCT7}}$	L7	$\overline{\text{INTP122/P36}}$	N11	$\overline{\text{SCK0/P42}}$
G14	$\overline{\text{OE/PCT6}}$	L8	SI2/INTP131/P31	N12	AV _{DD} /AV _{REF}
H1	$\overline{\text{DMARQ2/INTP102/P06}}$	L9	$\overline{\text{RESET}}$	N13	AV _{SS}
H2	$\overline{\text{DMARQ1/INTP101/P05}}$	L10	TXD1/SO1/P43	N14	–
H3	$\overline{\text{DMARQ0/INTP100/P04}}$	L11	ANI7/P77	P1	V _{DD}
H4	D1/PDL1	L12	ANI4/P74	P2	V _{SS}
H11	$\overline{\text{REFRQ/PCM4}}$	L13	ANI3/P73	P3	$\overline{\text{TC1/INTP111/P25}}$
H12	$\overline{\text{HLDRQ/PCM3}}$	L14	ANI2/P72	P4	INTP021/P22
H13	$\overline{\text{HLDAK/PCM2}}$	M1	–	P5	–
H14	CLKOUT/BUSCLK/PCM1	M2	INTP011/P12	P6	$\overline{\text{INTP121/P35}}$
J1	TO00/P03	M3	TO01/P13	P7	$\overline{\text{SCK2/INTP132/P32}}$
J2	TI000/INTP000/P01	M4	$\overline{\text{TC2/INTP112/P26}}$	P8	MODE1
J3	V _{DD}	M5	TI020/INTP020/P21	P9	CV _{DD}
J4	INTP001/P02	M6	V _{SS}	P10	X1
J11	TO03/P52	M7	$\overline{\text{RXD2/INTP120/P34}}$	P11	–
J12	TI030/INTP030/P50	M8	MODE0	P12	$\overline{\text{RXD1/SI1/P44}}$
J13	SELFREF/PCM5	M9	CKSEL	P13	$\overline{\text{RXD0/SI0/P41}}$
J14	INTP031/P51	M10	$\overline{\text{SCK1/P45}}$	P14	–
K1	PWM0/P00	M11	TXD0/SO0/P40		

Remarks 1. Leave the A1, A5, A10, B1, B14, C1, C14, D14, E5, L1, M1, M14, N1, N14, P5, P11, and P14 pins open.

2. Items in parentheses are pin names in the μ PD70F3107A.

(2) V850E/MA2

- 100-pin plastic LQFP (fine pitch) (14 × 14)
- μ PD703108GC-8EU

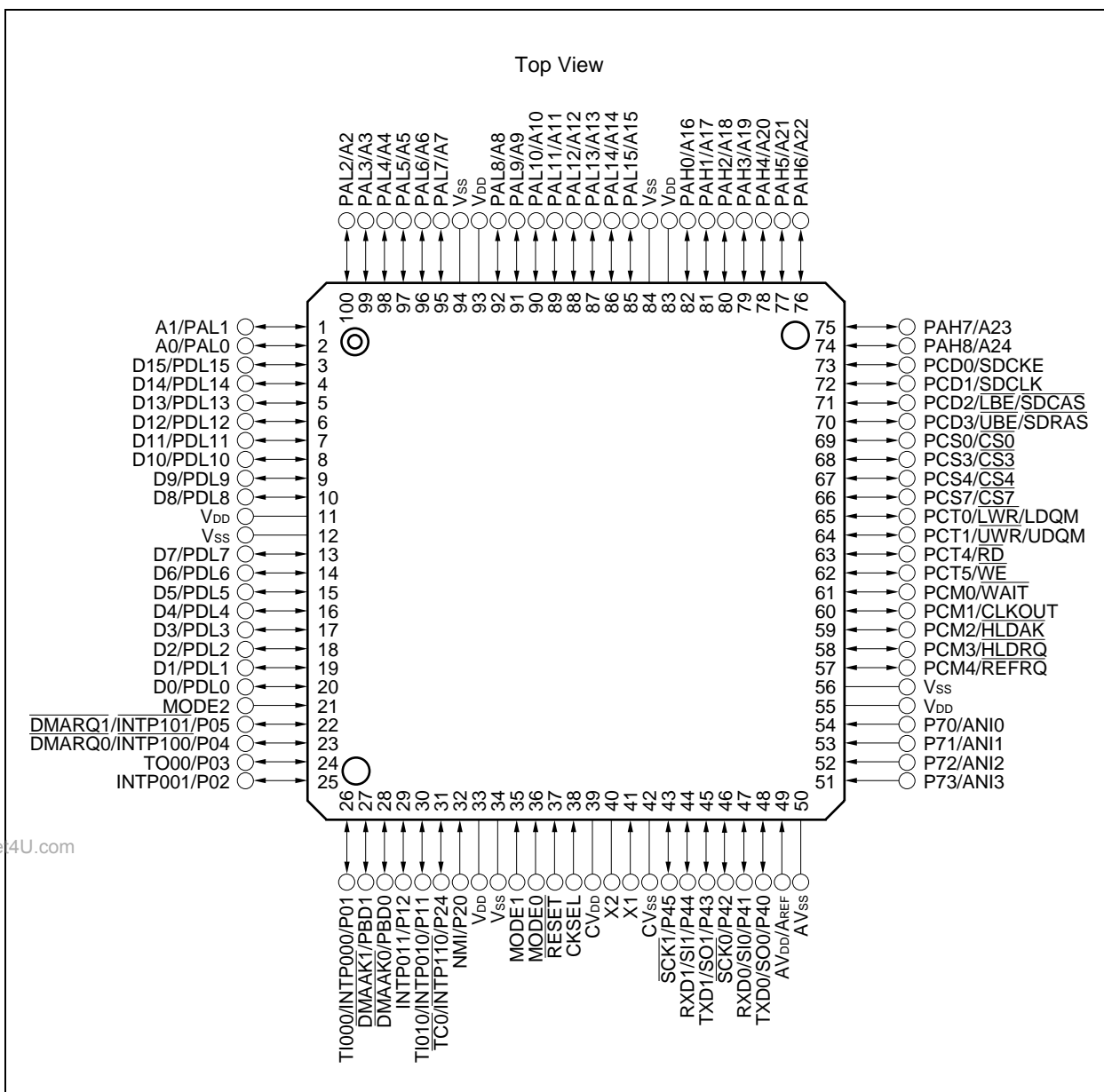

www.DataSheet4U.com

(3) V850E/MA3

- 144-pin plastic LQFP (fine pitch) (20 × 20)

μ PD703131AGJ-xxx-UEN	μ PD703133AGJ-xxx-UEN	μ PD70F3134AGJ-UEN
μ PD703131AYGJ-xxx-UEN	μ PD703133AYGJ-xxx-UEN	μ PD70F3134AYGJ-UEN
μ PD703132AGJ-xxx-UEN	μ PD703134AGJ-xxx-UEN	
μ PD703132AYGJ-xxx-UEN	μ PD703134AYGJ-xxx-UEN	

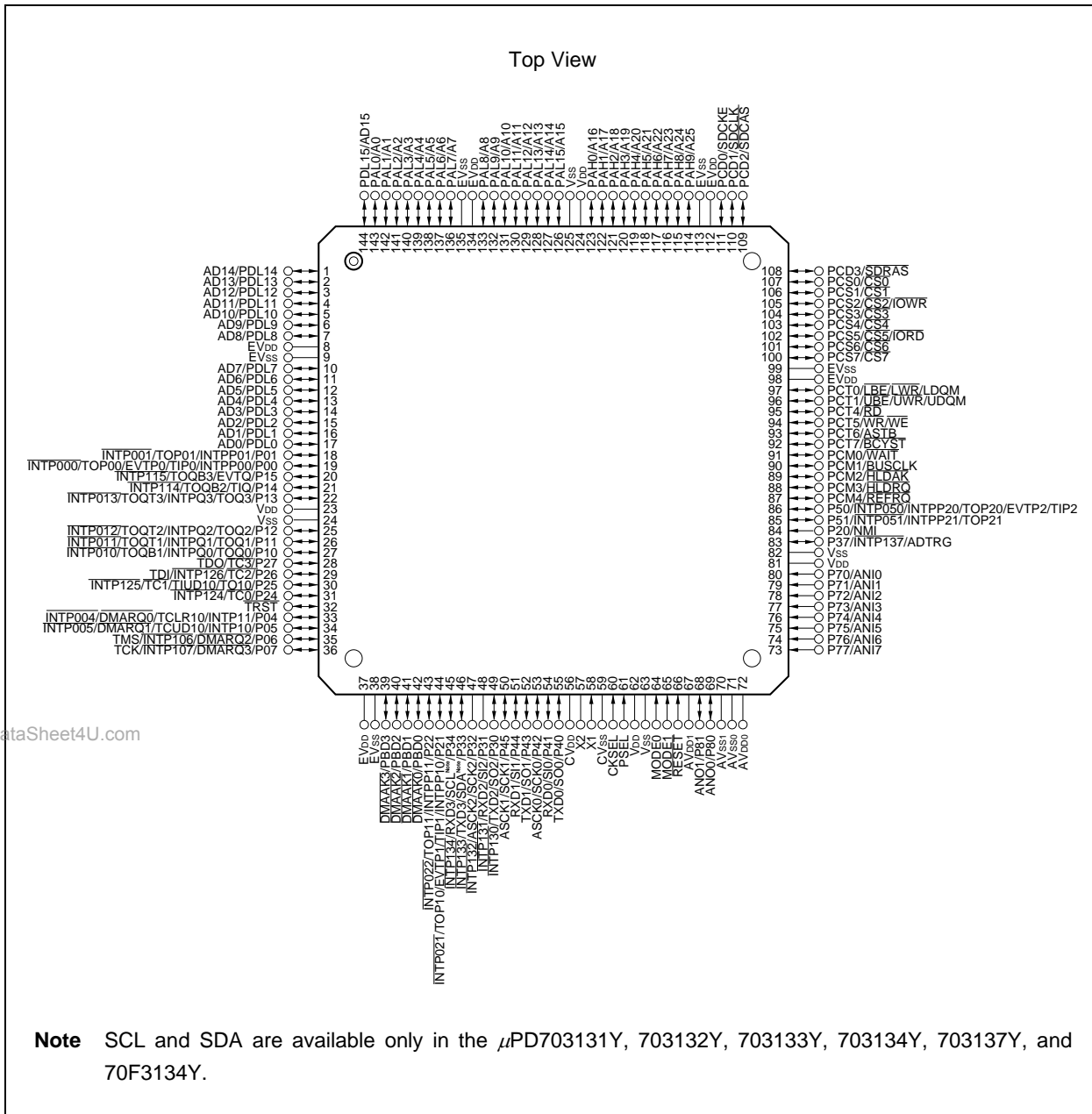

- 161-pin plastic FBGA (13 × 13)

μPD703131AF1-EN4

μPD703133AF1-xxx-EN4

μPD70F3134AF1-EN4

μPD703131AYF1-xxx-EN4

μPD703133AYF1-xxx-EN4

μPD70F3134AYF1-EN4

μPD703132AF1-xxx-EN4

μPD703134AF1-xxx-EN4

μPD703132AYF1-xxx-EN4

μPD703134AYF1-xxx-EN4

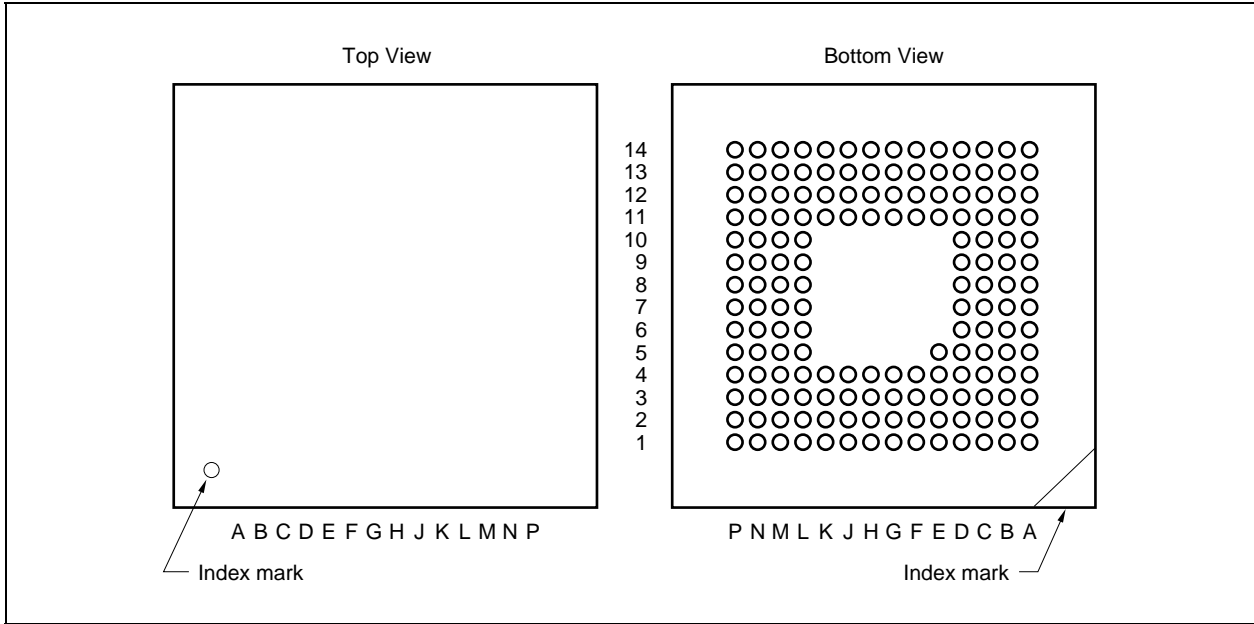

(1/2)

Pin No.	Name	Pin No.	Name	Pin No.	Name
A1	EV _{SS}	B8	V _{SS}	D1	EV _{SS}
A2	AD15/PDL15	B9	A18/PAH2	D2	AD10/PDL10
A3	A2/PAL2	B10	A21/PAH5	D3	AD14/PDL14
A4	A5/PAL5	B11	A25/PAH9	D4	A3/PAL3
A5	EV _{SS}	B12	SDCLK/PCD1	D5	A6/PAL6
A6	A9/PAL9	B13	$\overline{CS1}$ /PCS1	D6	A10/PAL10
A7	A12/PAL12	B14	EV _{SS}	D7	A14/PAL14
A8	A15/PAL15	C1	EV _{SS}	D8	A16/PAH0
A9	A17/PAH1	C2	AD9/PDL9	D9	A20/PAH4
A10	-	C3	AD13/PDL13	D10	A23/PAH7
A11	A24/PAH8	C4	A1/PAL1	D11	SDCKE/PCD0
A12	EV _{DD}	C5	A7/PAL7	D12	$\overline{CS0}$ /PCS0
A13	\overline{SDCAS} /PCD2	C6	EV _{DD}	D13	$\overline{CS5}$ / \overline{IORD} /PCS5
A14	\overline{SDRAS} /PCD3	C7	A11/PAL11	D14	EV _{SS}
B1	EV _{SS}	C8	V _{DD}	E1	AD5/PDL5
B2	AD12/PDL12	C9	A19/PAH3	E2	AD7/PDL7
B3	A0/PAL0	C10	A22/PAH6	E3	AD8/PDL8
B4	A4/PAL4	C11	EV _{SS}	E4	AD11/PDL11
B5	EV _{SS}	C12	$\overline{CS3}$ /PCS3	E5	-
B6	A8/PAL8	C13	$\overline{CS2}$ / \overline{IOWR} /PCS2	E11	$\overline{CS6}$ /PCS6
B7	A13/PAL13	C14	EV _{SS}	E12	$\overline{CS4}$ /PCS4

(2/2)

Pin No.	Name	Pin No.	Name	Pin No.	Name
E13	$\overline{CS7}/PCS7$	J14	NMI/P20	M11	AV _{SS0}
E14	EV _{SS}	K1	TOQT1/ $\overline{INTP011}/\overline{INTPQ1}/TOQ1/P11$	M12	ANI6/P76
F1	AD2/PDL2	K2	$\overline{TC3}/\overline{TDO}/P27$	M13	ANI5/P75
F2	AD3/PDL3	K3	$\overline{TC0}/\overline{INTP124}/P24$	M14	–
F3	AD4/PDL4	K4	$\overline{TC2}/\overline{TDI}/\overline{INTP126}/P26$	N1	EV _{SS}
F4	EV _{DD}	K11	ANI1/P71	N2	$\overline{DMARQ3}/\overline{TCK}/\overline{INTP107}/P07$
F11	$\overline{RD}/PCT4$	K12	ANI0/P70	N3	$\overline{DMAAK3}/PBD3$
F12	EV _{DD}	K13	V _{SS}	N4	$\overline{DMAAK0}/PBD0$
F13	$\overline{LBE}/\overline{LWR}/\overline{LDQM}/PCT0$	K14	V _{DD}	N5	TXD3/SDA ^{Note} / $\overline{INTP133}/P33$
F14	$\overline{UBE}/\overline{UWR}/\overline{UDQM}/PCT1$	L1	EV _{SS}	N6	TXD2/SO2/ $\overline{INTP130}/P30$
G1	TOP01/ $\overline{INTP001}/\overline{INTPP01}/P01$	L2	TC1/TIUD10/TO10/ $\overline{INTP125}/P25$	N7	ASCK0/SCK0/P42
G2	TOP00/ $\overline{INTP000}/\overline{EVTP0}/\overline{TIP0}/\overline{INTPP00}/P00$	L3	$\overline{DMARQ2}/\overline{TMS}/\overline{INTP106}/P06$	N8	V _{SS}
G3	AD0/PDL0	L4	\overline{TRST}	N9	X2
G4	AD6/PDL6	L5	TOP11/ $\overline{INTPP11}/\overline{INTP022}/P22$	N10	CV _{SS}
G11	$\overline{WAIT}/PCM0$	L6	ASCK2/SCK2/ $\overline{INTP132}/P32$	N11	ANO1/P81
G12	$\overline{WR}/\overline{WE}/PCT5$	L7	ASCK1/SCK1/P45	N12	AV _{SS1}
G13	$\overline{BCYST}/PCT7$	L8	TXD0/SO0/P40	N13	AV _{DD1}
G14	ASTB/PCT6	L9	MODE0	N14	–
H1	TOQB3/ $\overline{INTP115}/\overline{EVTQ}/P15$	L10	AV _{DD0}	P1	EV _{DD}
H2	TOQB2/ $\overline{INTP114}/\overline{TIQ}/P14$	L11	ANI7/P77	P2	EV _{SS}
H3	TOQT3/ $\overline{INTP013}/\overline{INTPQ3}/TOQ3/P13$	L12	ANI4/P74	P3	$\overline{DMAAK1}/PBD1$
H4	AD1/PDL1	L13	ANI3/P73	P4	TOP10/ $\overline{INTPP10}/\overline{EVTP1}/\overline{TIP1}/\overline{INTP021}/P21$
H11	$\overline{REFRQ}/PCM4$	L14	ANI2/P72	P5	EV _{SS}
H12	$\overline{HLDRQ}/PCM3$	M1	EV _{SS}	P6	RXD1/SI1/P44
H13	HLDAK/PCM2	M2	$\overline{DMARQ1}/\overline{TCUD10}/\overline{INTP10}/\overline{INTP005}/P05$	P7	RXD0/SI0/P41
H14	BUSCLK/PCM1	M3	$\overline{DMARQ0}/\overline{INTP11}/\overline{TCLR10}/\overline{INTP004}/P04$	P8	PSEL
J1	V _{DD}	M4	$\overline{DMAAK2}/PBD2$	P9	CV _{DD}
J2	TOQT2/ $\overline{INTP012}/\overline{INTPQ2}/TOQ2/P12$	M5	RXD3/SCL ^{Note} / $\overline{INTP134}/P34$	P10	X1
J3	TOQB1/ $\overline{INTP010}/\overline{INTPQ0}/TOQ0/P10$	M6	RXD2/SI2/ $\overline{INTP131}/P31$	P11	–
J4	V _{SS}	M7	TXD1/SO1/P43	P12	\overline{RESET}
J11	ADTRG/ $\overline{INTP137}/P37$	M8	V _{DD}	P13	ANO0/P80
J12	TOP21/ $\overline{INTPP21}/\overline{INTP051}/P51$	M9	CKSEL	P14	–
J13	TOP20/ $\overline{INTPP20}/\overline{EVTP2}/\overline{TIP2}/\overline{INTP050}/P50$	M10	MODE1		

Note SCL and SDA are available only in the μ PD703131AY, 703132AY, 703133AY, 703134AY, and 70F3134AY.

Remark Leave the A10, E5, M14, N14, P11, and P14 pins open.

(4) V850E/ME2

- 176-pin plastic LQFP (fine pitch) (24 × 24)
- μ PD703111AGM-10-UEU
- μ PD703111AGM-13-UEU
- μ PD703111AGM-15-UEU

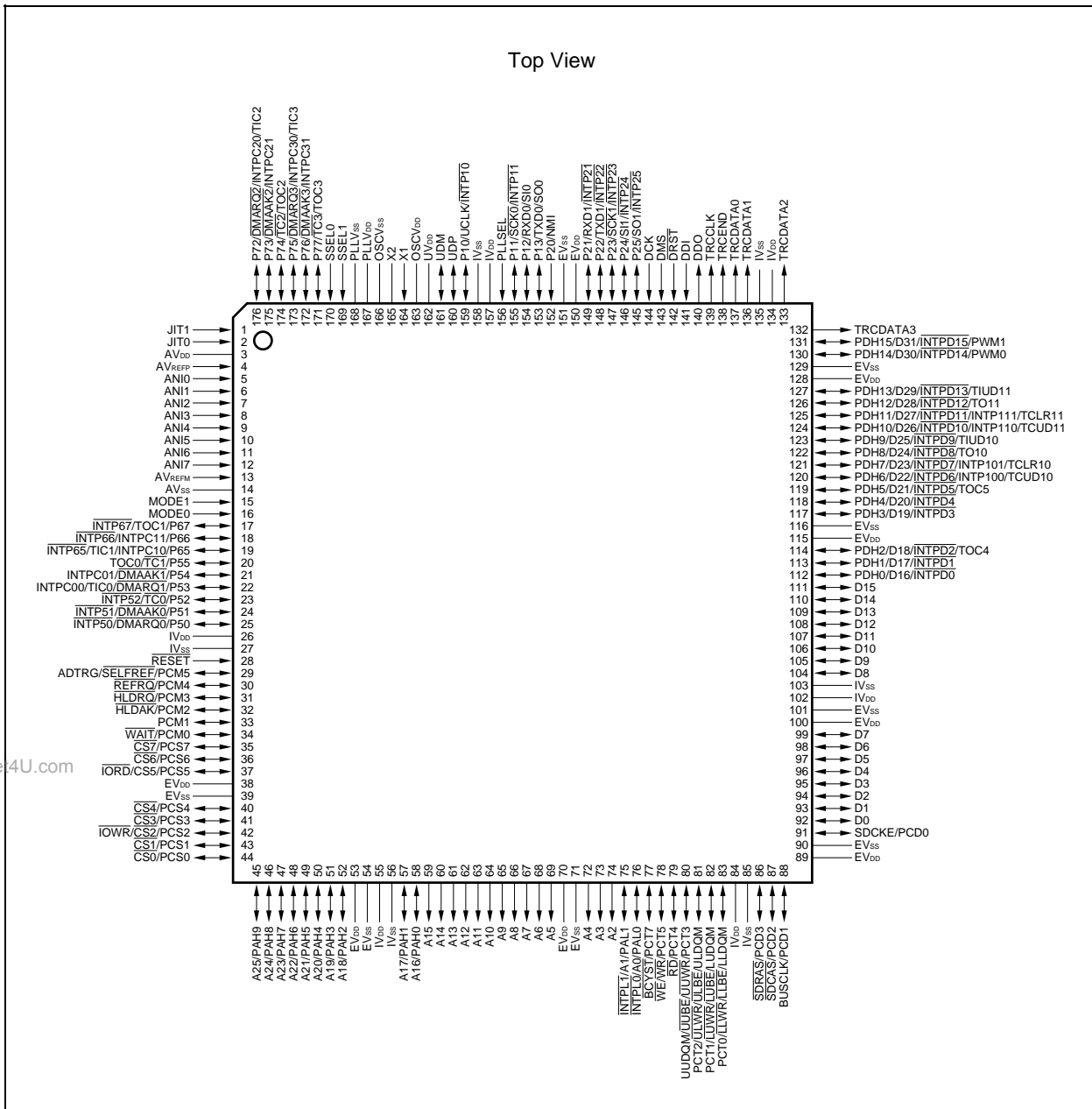

- 240-pin plastic FBGA (16 × 16)
 μ PD703111AF1-10-GA3
 μ PD703111AF1-13-GA3
 μ PD703111AF1-15-GA3

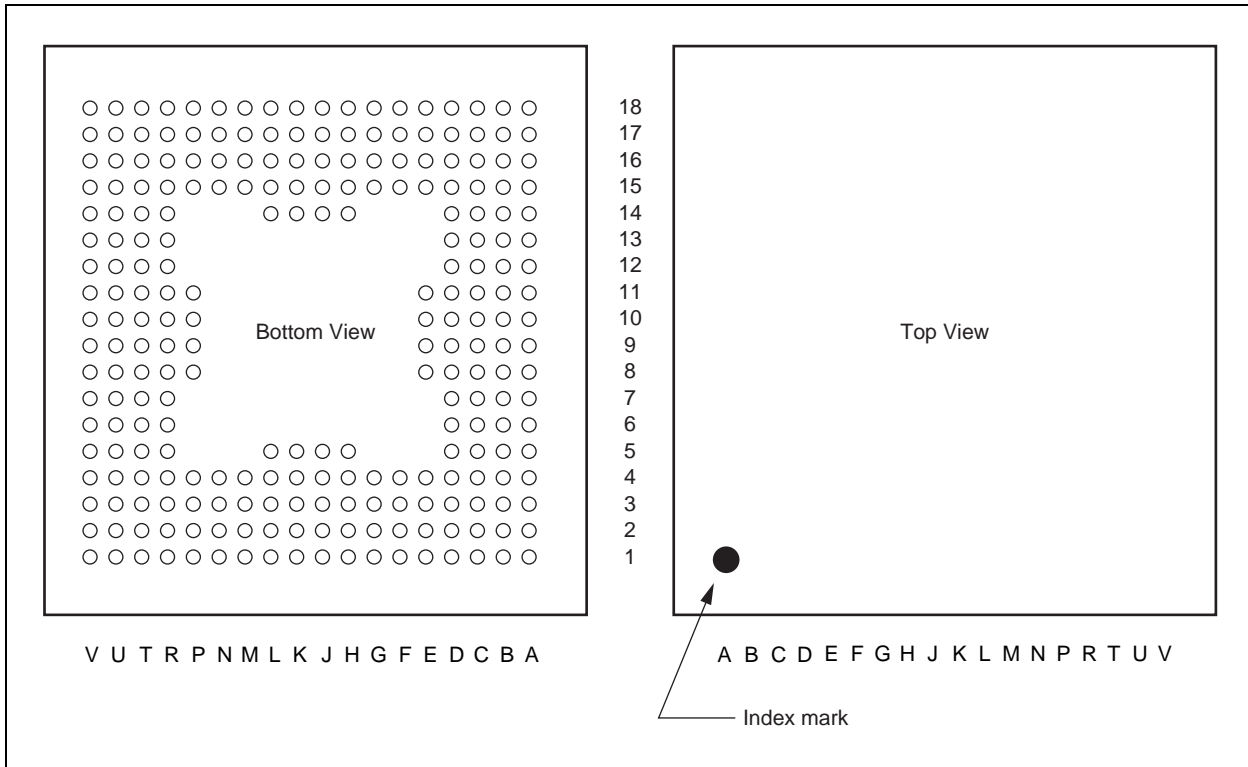

(1/2)

Pin No.	Name	Pin No.	Name	Pin No.	Name
A1	–	C12	IV _{DD}	G3	EV _{SS}
A2	IV _{SS}	C13	PAH2/A18	G4	D7
A3	PCT0/LLWR/LLBE/LLDQM	C14	PAH4/A20	G15	PCM1
A4	–	C15	PAH6/A22	G16	PCM3/HLDRQ
A5	PCT4/RD	C16	–	G17	PCM4/REFRQ
A6	–	C17	PCS0/CS0	G18	PCM5/ADTRG/SELFRF
A7	–	C18	–	H1	–
A8	EV _{DD}	D1	D0	H2	D8
A9	A9	D2	EV _{SS}	H3	D9
A10	–	D3	PCD0/SDCKE	H4	D10
A11	A14	D4	EV _{DD}	H5	IV _{SS}
A12	IV _{SS}	D5	PCT1/LUWR/LUBE/LUDQM	H14	–
A13	EV _{DD}	D6	–	H15	RESET
A14	–	D7	PAL0/INTPL0/A0	H16	IV _{SS}
A15	PAH5/A21	D8	A4	H17	–
A16	PAH7/A23	D9	A6	H18	IV _{DD}
A17	PAH9/A25	D10	–	J1	–
A18	–	D11	A13	J2	D11
B1	–	D12	EV _{SS}	J3	D12
B2	PCD1/BUSCLK	D13	PAH3/A19	J4	–
B3	PCD2/SDCAS	D14	–	J5	D13
B4	–	D15	–	J14	–
B5	PCT3/UUWR/UUBE/UUDQM	D16	PCS2/CS2/IOWR	J15	P50/INTP50/DMARQ0
B6	PCT7/BCYST	D17	PCS3/CS3	J16	P51/INTP51/DMAAK0
B7	A2	D18	EV _{DD}	J17	P52/INTP52/TC0
B8	–	E1	D3	J18	P53/INTPC00/TIC0/DMARQ1
B9	A8	E2	D2	K1	D14
B10	A12	E3	D1	K2	D15
B11	PAH0/A16	E4	–	K3	PDH0/D16/INTPD0
B12	–	E8	A3	K4	PDH1/D17/INTPD1
B13	–	E9	A5	K5	PDH2/D18/INTPD2/TOC4
B14	–	E10	A10	K14	P55/TOC0/TC1
B15	–	E11	PAH1/A17	K15	P54/INTPC01/DMAAK1
B16	PAH8/A24	E15	PCS4/CS4	K16	P65/INTP65/INTPC10/TIC1
B17	–	E16	EV _{SS}	K17	P66/INTP66/INTPC11
B18	PCS1/CS1	E17	PCS5/CS5/IORD	K18	–
C1	–	E18	PCS6/CS6	L1	EV _{DD}
C2	–	F1	D6	L2	–
C3	PCD3/SDRAS	F2	D5	L3	EV _{SS}
C4	IV _{DD}	F3	D4	L4	PDH3/D19/INTPD3
C5	PCT2/ULWR/ULBE/ULDQM	F4	–	L5	PDH4/D20/INTPD4
C6	PCT5/WE/WR	F15	–	L14	MODE1
C7	PAL1/INTPL1/A1	F16	PCS7/CS7	L15	–
C8	EV _{SS}	F17	PCM0/WAIT	L16	MODE0
C9	A7	F18	PCM2/HLDAK	L17	–
C10	A11	G1	IV _{DD}	L18	P67/INTP67/TOC1
C11	A15	G2	EV _{DD}	M1	–

(2/2)

Pin No.	Name	Pin No.	Name	Pin No.	Name
M2	PDH5/D21/ $\overline{\text{INTPD5}}$ /TOC5	R7	DCK	U4	–
M3	PDH6/D22/ $\overline{\text{INTPD6}}$ / $\overline{\text{INTP100}}$ /TCUD10	R8	EV _{DD}	U5	TRCCLK
M4	–	R9	P11/ $\overline{\text{INTP11}}$ / $\overline{\text{SCK0}}$	U6	$\overline{\text{DRST}}$
M15	ANI6	R10	IV _{SS}	U7	P25/ $\overline{\text{INTP25}}$ /SO1
M16	AV _{REFM}	R11	UDM	U8	P22/ $\overline{\text{INTP22}}$ /TXD1
M17	ANI7	R12	X2	U9	EV _{SS}
M18	AV _{SS}	R13	PLL _{VDD}	U10	IV _{DD}
N1	PDH7/D23/ $\overline{\text{INTPD7}}$ / $\overline{\text{INTP101}}$ /TCLR10	R14	SSEL0	U11	–
N2	PDH8/D24/ $\overline{\text{INTPD8}}$ /TO10	R15	–	U12	OSCV _{DD}
N3	PDH9/D25/ $\overline{\text{INTPD9}}$ /TIUD10	R16	AV _{REFP}	U13	–
N4	PDH10/D26/ $\overline{\text{INTPD10}}$ / $\overline{\text{INTP110}}$ /TCUD11	R17	AV _{DD}	U14	–
N15	ANI2	R18	–	U15	P76/ $\overline{\text{INTPC31}}$ / $\overline{\text{DMAAK3}}$
N16	ANI3	T1	EV _{DD}	U16	P73/ $\overline{\text{INTPC21}}$ / $\overline{\text{DMAAK2}}$
N17	ANI4	T2	TRCDATA3	U17	P72/ $\overline{\text{INTPC20}}$ /TIC2/ $\overline{\text{DMARQ2}}$
N18	ANI5	T3	–	U18	–
P1	–	T4	TRCDATA1	V1	–
P2	PDH11/D27/ $\overline{\text{INTPD11}}$ / $\overline{\text{INTP111}}$ /TCLR11	T5	TRCEND	V2	TRCDATA2
P3	PDH13/D29/ $\overline{\text{INTPD13}}$ /TIUD11	T6	DDI	V3	IV _{SS}
P4	–	T7	–	V4	TRCDATA0
P8	P23/ $\overline{\text{INTP23}}$ / $\overline{\text{SCK1}}$	T8	P21/ $\overline{\text{INTP21}}$ /RXD1	V5	–
P9	P12/SI0/RXD0	T9	P20/NMI	V6	DMS
P10	–	T10	–	V7	P24/ $\overline{\text{INTP24}}$ /SI1
P11	UV _{DD}	T11	UDP	V8	–
P15	–	T12	X1	V9	P13/SO0/TXD0
P16	ANI0	T13	OSCV _{SS}	V10	PLLSEL
P17	ANI1	T14	SSEL1	V11	P10/ $\overline{\text{INTP10}}$ /UCLK
P18	–	T15	P75/ $\overline{\text{INTPC30}}$ /TIC3/ $\overline{\text{DMARQ3}}$	V12	–
R1	PDH12/D28/ $\overline{\text{INTPD12}}$ /TO11	T16	–	V13	–
R2	EV _{SS}	T17	JIT1	V14	–
R3	PDH14/D30/ $\overline{\text{INTPD14}}$ /PWM0	T18	JIT0	V15	PLL _{VSS}
R4	IV _{DD}	U1	PDH15/D31/ $\overline{\text{INTPD15}}$ /PWM1	V16	P77/ $\overline{\text{TOC3}}$ / $\overline{\text{TC3}}$
R5	–	U2	–	V17	P74/ $\overline{\text{TOC2}}$ / $\overline{\text{TC2}}$
R6	DDO	U3	–	V18	–

Remark Leave the A1, A4, A6, A7, A10, A14, A18, B1, B4, B8, B12 to B15, B17, C1, C2, C16, C18, D6, D10, D14, D15, E4, F4, F15, H1, H14, H17, J1, J4, J14, K18, L2, L15, L17, M1, M4, P1, P4, P10, P15, P18, R5, R15, R18, T3, T7, T10, T16, U2 to U4, U11, U13, U14, U18, V1, V5, V8, V12 to V14, and V18 pins open.

1.5 Internal Block Diagram

(1) V850E/MA1

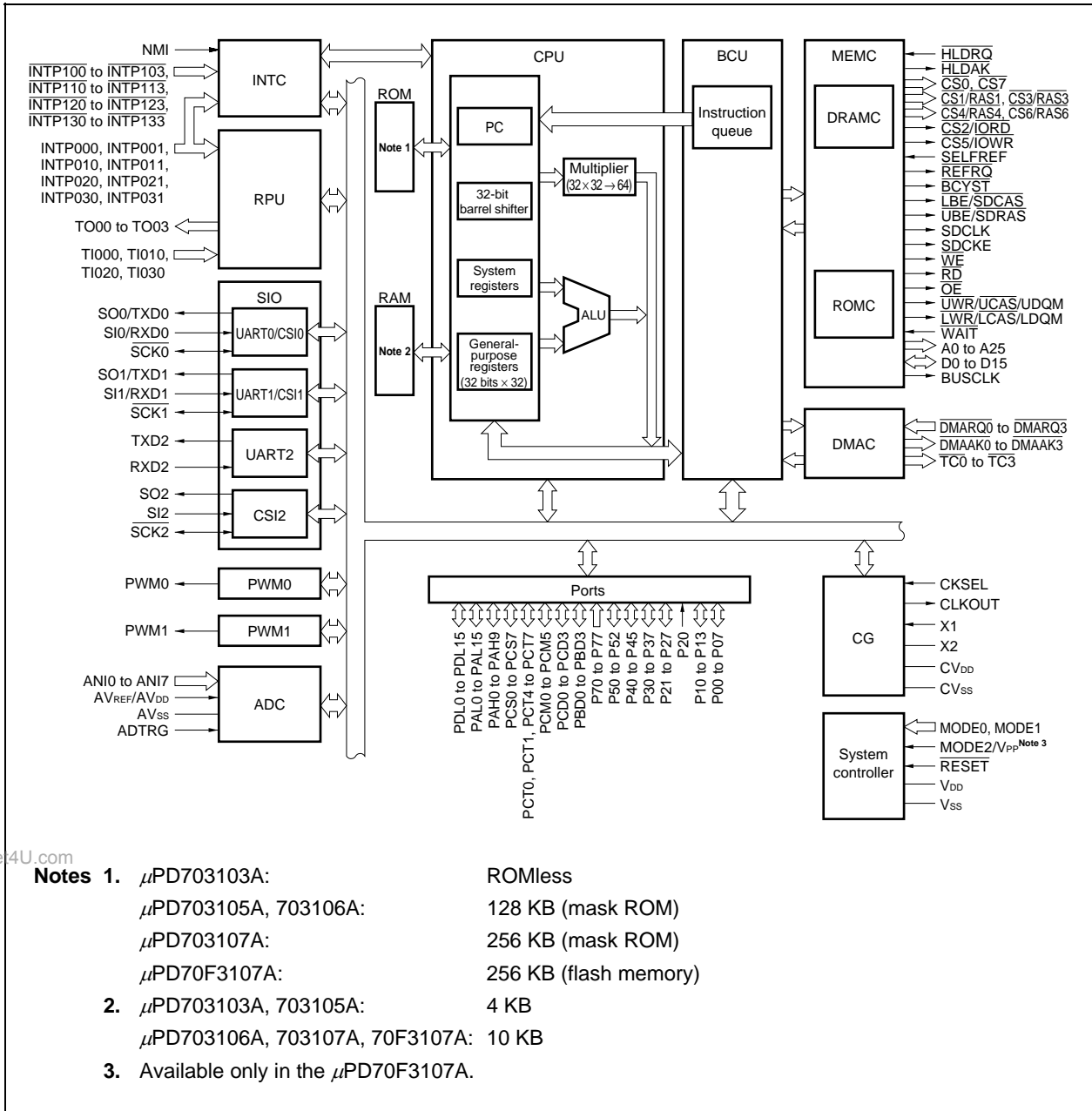

www.DataSheet4U.com

(2) V850E/MA2

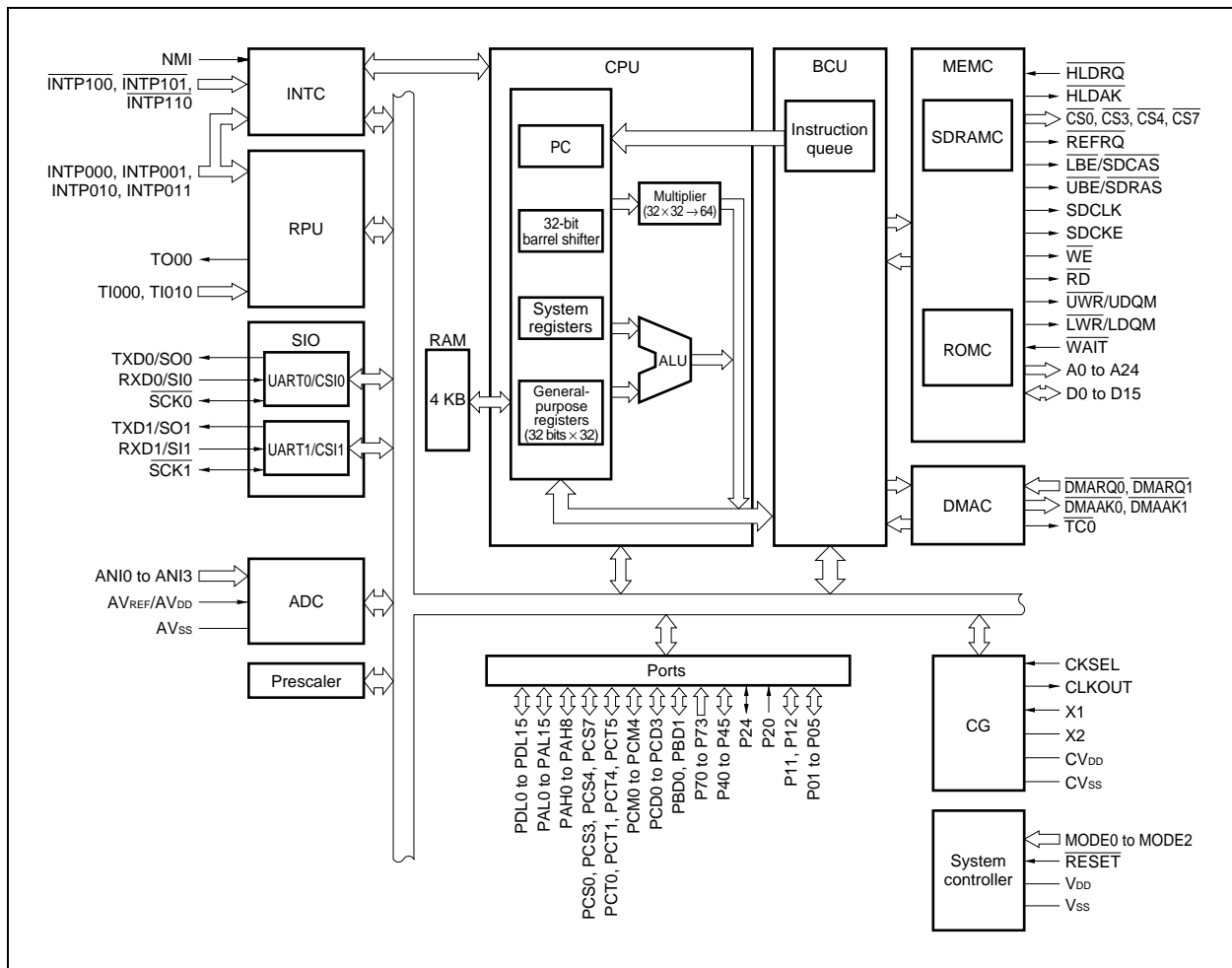

(3) V850E/MA3

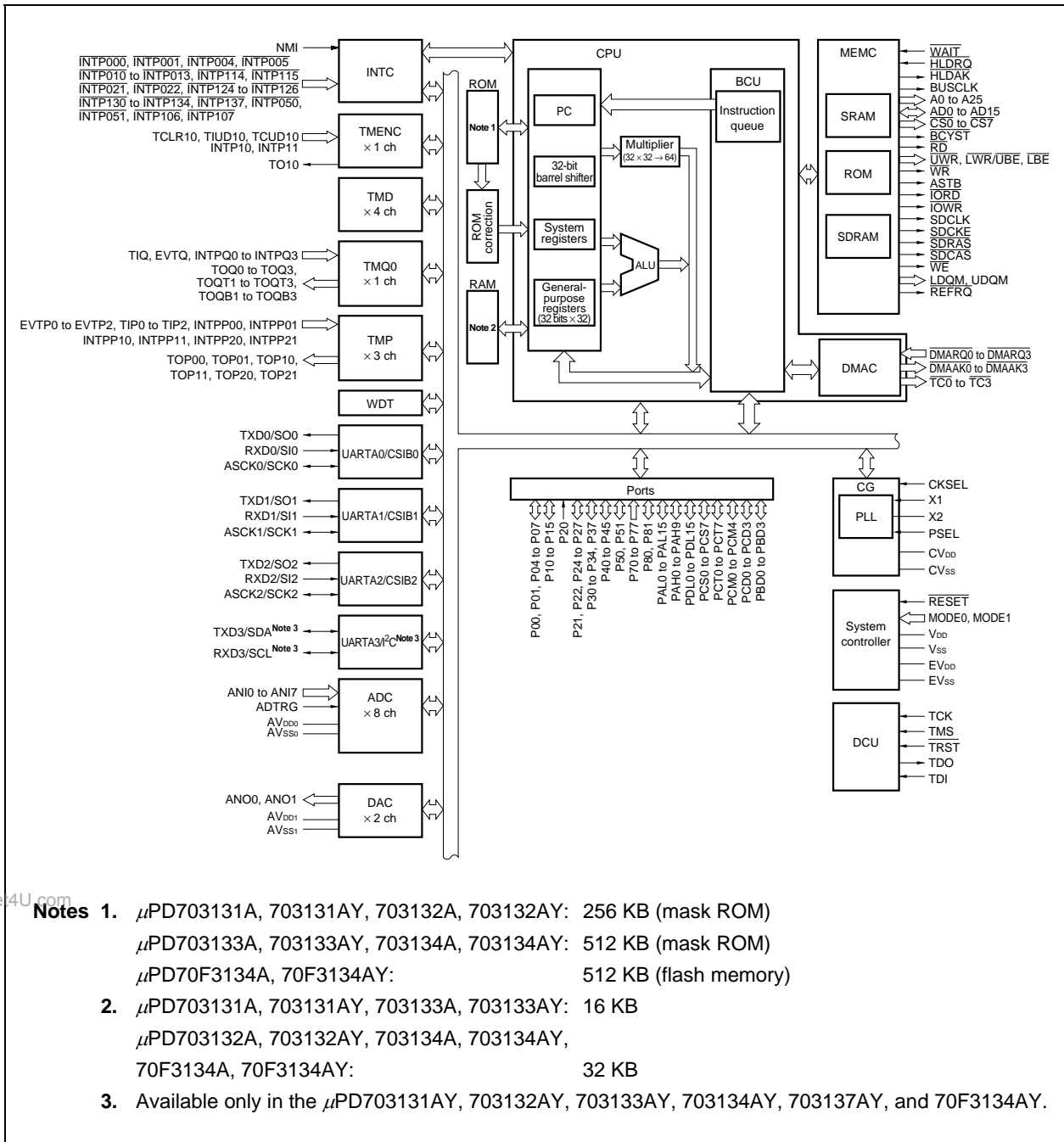

www.DataSheet4U.com

- Notes**
- μ PD703131A, 703131AY, 703132A, 703132AY: 256 KB (mask ROM)
 - μ PD703133A, 703133AY, 703134A, 703134AY: 512 KB (mask ROM)
 - μ PD70F3134A, 70F3134AY: 512 KB (flash memory)
 - μ PD703131A, 703131AY, 703133A, 703133AY: 16 KB
 - μ PD703132A, 703132AY, 703134A, 703134AY, 70F3134A, 70F3134AY: 32 KB
 - Available only in the μ PD703131AY, 703132AY, 703133AY, 703134AY, 703137AY, and 70F3134AY.

(4) V850E/ME2

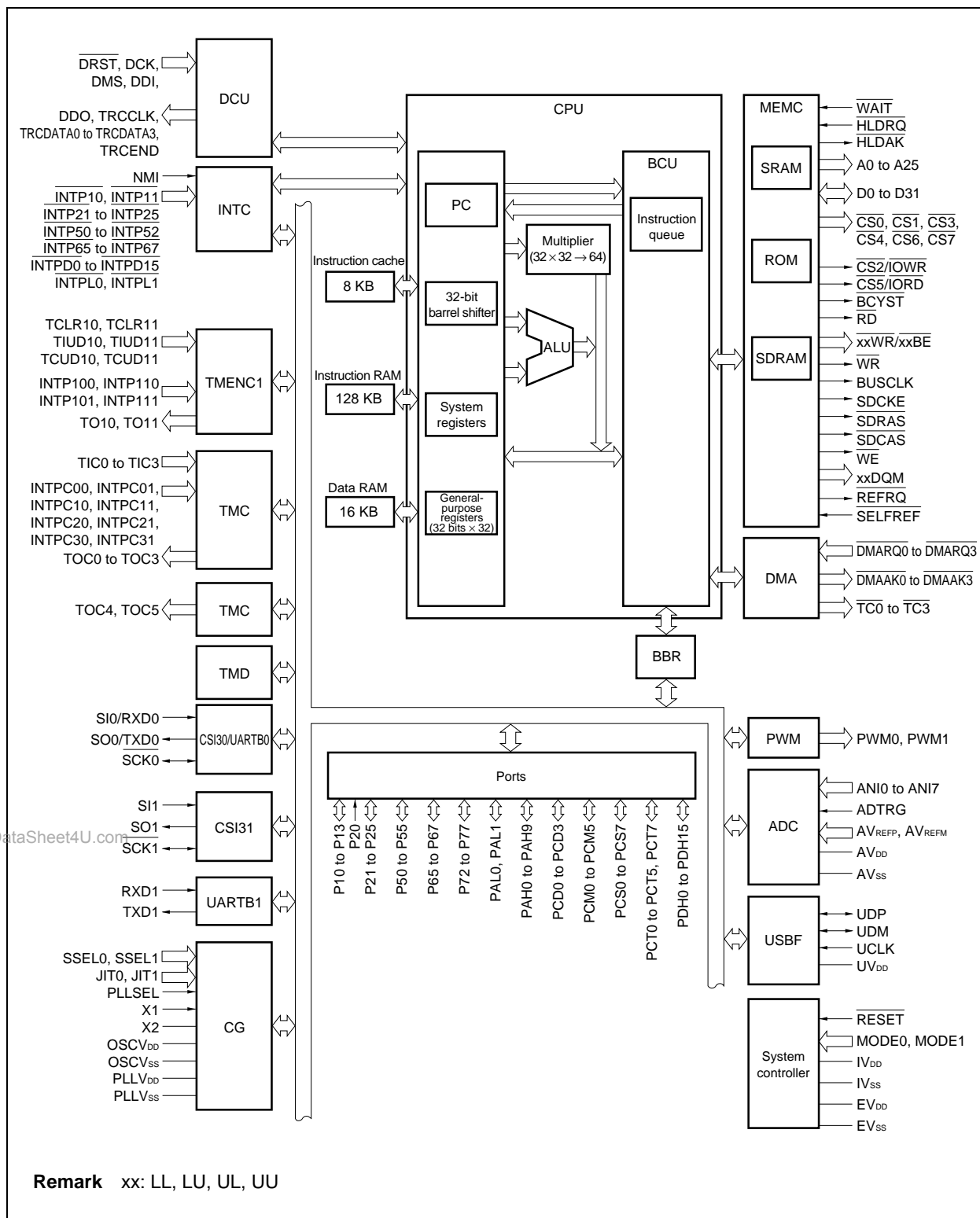

CHAPTER 2 OVERVIEW OF PCI HOST BRIDGE MACRO

The PCI host bridge macro enables connection of V850E/MA1, V850E/MA2, V850E/MA3, V850E/ME2 external bus interfaces to the PCI bus interface. This chapter gives an outline of the PCI host bridge macro.

2.1 Outline

The PCI host bridge macro is a bridge control macro that connects V850E/MA1, V850E/MA2, V850E/MA3, V850E/ME2 external bus interfaces (memory controller (MEMC)) to the PCI bus interface.

The main memory (SDRAM) can be directly controlled when SDRAM is accessed from a PCI device.

2.2 Features

The features of the PCI host bridge macro are as follows.

- PCI bus master cycle control
 - PCI configuration register read/write single cycle
 - PCI I/O register read/write single cycle
 - PCI memory read/write single cycle
- PCI bus slave cycle control
 - PCI memory read/write cycle (burst transfer up to 8 doublewords (32 bits × 8 bursts))
- PCI bus arbiter control
 - Up to 8 masters can be controlled (one of them is occupied by the PCI host bridge macro)
 - Bus parking master: Limited to PCI host bridge macro/selectable from the last accessed master
- PCI bus error processing
 - An error interrupt is generated for master abort/target abort/PERR# reception/SERR# reception
 - The address immediately before an error occurs is retained
- PCI bus address conversion control
 - PCI I/O address and PCI memory address registers are supported to convert the physical addresses from the CPU to addresses for the PCI bus
- CPU interface control
 - External bus interface (MEMC)
 - Data bus width: 32 bits/16 bits
 - Cycle control by hardware wait control
- SDRAM control
 - SDRAM is controlled in response to main memory (SDRAM) access from the PCI device
 - Data bus width: 16 bits/32 bits are supported
- PCI clock
 - 33 MHz supported
 - SDRAM control and PCI control clocks are designed to be asynchronous

CHAPTER 3 SPECIFICATIONS OF PCI HOST BRIDGE MACRO

This chapter describes the block diagram, signals, register specifications, and operation specifications of the PCI host bridge macro.

3.1 Internal Blocks of PCI Host Bridge Macro

The PCI host bridge macro consists of the four blocks shown in **Figure 3-1 General Block Diagram of PCI Host Bridge Macro**. The functions of each block are described below.

(1) LM_BRIDGE: External bus interface master controller

This controller is connected to the external bus interface, responds to accesses from the CPU, and issues an access request to the PH_FLIP_BRIDGE block of the PCI bus controller. A bus width of 16 bits or 32 bits can be accessed from the CPU.

(2) LS_BRIDGE: External bus interface slave controller

This controller responds to accesses from the PH_FLIP_BRIDGE block of the PCI bus controller in response to a memory data transfer request from the PCI device and issues an access request to SDRAMC.

(3) SDRAMC: External bus interface SDRAM controller

This controller is connected to the SDRAM bus. A memory request from the PCI device via the LS_BRIDGE block is transferred by activating the SDRAM bus.

When the bus width of SDRAM is 16 bits, memory cycles of up to 8 bursts are started. When the bus width is 32 bits, memory cycles of up to 4 bursts are started.

(4) PH_FLIP_BRIDGE: External bus interface host controller

This controller is connected to the PCI bus and operates as the PCI host device.

A PCI configuration register read/write cycle, PCI IO register read/write cycle, and PCI memory read/write cycle are started in response to a request from the LM_BRIDGE block.

Moreover, a request is issued to the LS_BRIDGE block in response to a memory data transfer request from the PCI device connected to the PCI bus.

Figure 3-1. General Block Diagram of PCI Host Bridge Macro

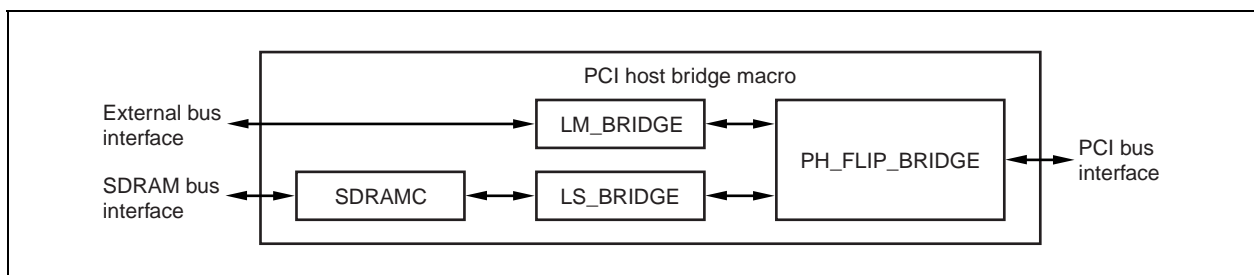

3.2 Relationship Between Internal Blocks and Signals

The I/O signals for each block of the PCI host bridge macro are as follows.

Figure 3-2. Blocks and Pin Signals of PCI Host Bridge Macro

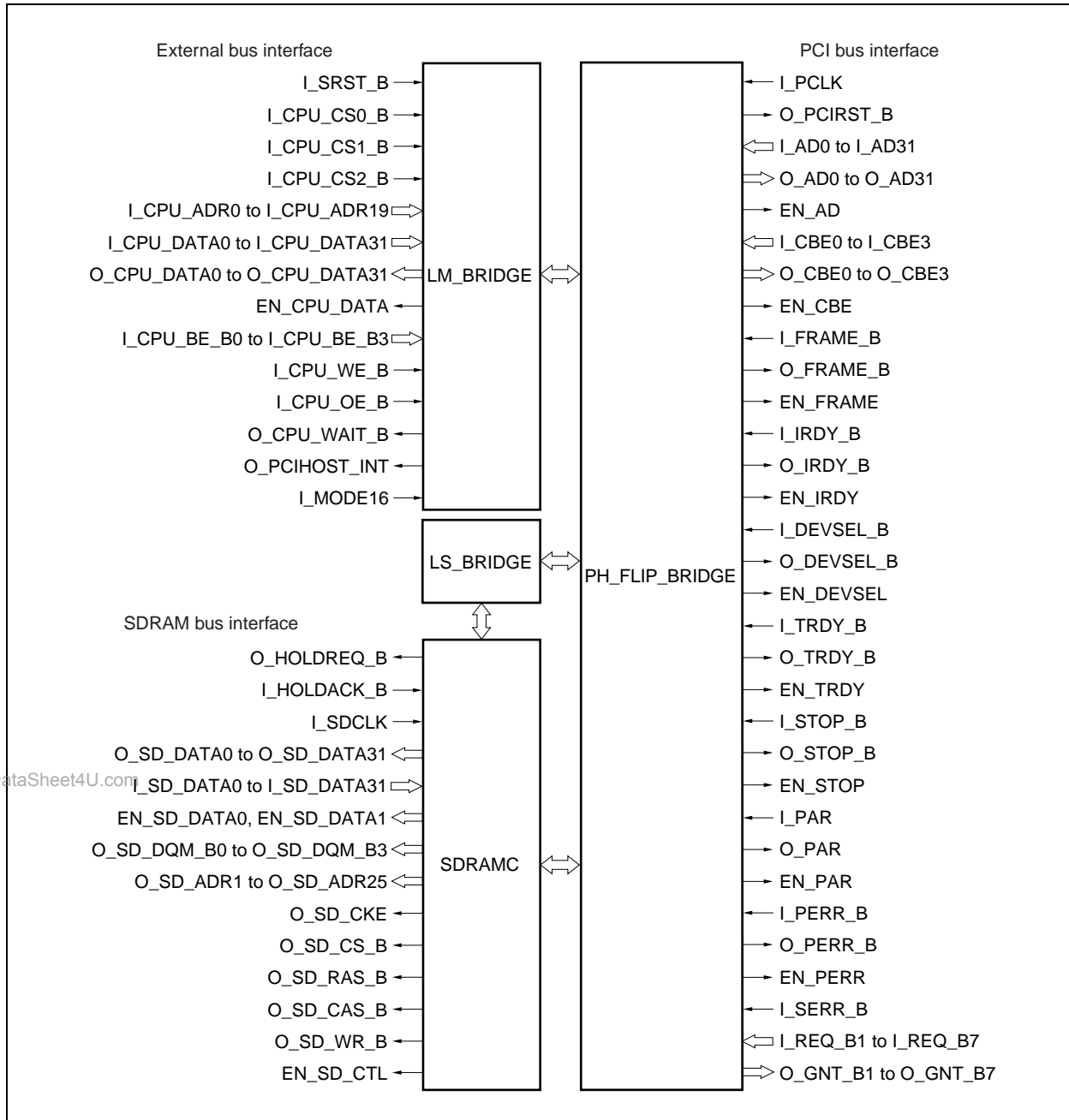

3.3 Pin Functions

The pin functions of each interface are described below.

3.3.1 External bus slave interface pins

Pin Name	I/O	Function	Active
I_SRST_B	Input	System reset input	Low
I_CPU_CS0_B	Input	PCI host bridge register chip select input	Low
I_CPU_CS1_B	Input	PCI I/O area chip select input	Low
I_CPU_CS2_B	Input	PCI memory area chip select input	Low
I_CPU_ADR0 to I_CPU_ADR19	Input	CPU address input	–
I_CPU_DATA0 to I_CPU_DATA31	Input	CPU data input	–
O_CPU_DATA0 to O_CPU_DATA31	Output	CPU data output	–
EN_CPU_DATA	Output	CPU data output enable output	High
I_CPU_BE_B0 to I_CPU_BE_B3	Input	CPU data byte enable input	–
I_CPU_WE_B	Input	CPU write data enable input	Low
I_CPU_OE_B	Input	CPU read data output enable input	Low
O_CPU_WAIT_B	Output	CPU data wait output	Low
O_PCIHOST_INT	Output	PCI host bridge interrupt output	Low
I_MODE16	Input	CPU data bus width select input	Low: 32-bit width High: 16-bit width

3.3.2 SDRAM bus interface pins

Pin Name	I/O	Function	Active
O_HOLDREQ_B	Output	SDRAM bus hold request output	Low
I_HOLDACK_B	Input	SDRAM bus hold acknowledge input	Low
I_SDCLK	Input	SDRAM clock input	–
O_SD_DATA0 to O_SD_DATA31	Output	SDRAM data output	–
I_SD_DATA0 to I_SD_DATA31	Input	SDRAM data input	–
EN_SD_DATA0, EN_SD_DATA1	Output	SDRAM data enable output Low: Lower 16 bits (O_SD_DATA0 to O_SD_DATA15) High: Higher 16 bits (O_SD_DATA16 to O_SD_DATA31)	←
O_SD_DQM_B0 to O_SD_DQM_B3	Output	SDRAM data mask output	Low
O_SD_ADR1 to O_SD_ADR25	Output	SDRAM address output	–
O_SD_CKE	Output	SDRAM clock enable output	High
O_SD_CS_B	Output	SDRAM chip select output	Low
O_SD_RAS_B	Output	SDRAM row address strobe output	Low
O_SD_CAS_B	Output	SDRAM column address strobe output	Low
O_SD_WR_B	Output	SDRAM read/write output	Low
EN_SD_CTL	Output	SDRAM control signal output enable output (Output buffer enable of O_SD_ADR1 to O_SD_ADR25, O_SD_CKE, O_SD_CS_B, O_SD_RAS_B, O_SD_CAS_B, and O_SD_WR_B pins)	High

3.3.3 PCI bus interface pins

Pin Name	I/O	Function	Active
I_PCLK	Input	PCI clock input	–
O_PCIRST_B	Output	PCI reset output	Low
I_AD0 to I_AD31	Input	PCI address/data input	–
O_AD0 to O_AD31	Output	PCI address/data output	–
EN_AD	Output	PCI address/data output enable output (Output buffer enable of O_AD0 to O_AD31)	High
I_CBE0 to I_CBE3	Input	PCI command/byte enable input	Low
O_CBE0 to O_CBE3	Output	PCI command/byte enable output	Low
EN_CBE	Output	PCI command/byte enable output enable output (Output buffer enable of O_CBE0 to O_CBE3)	High
I_FRAME_B	Input	PCI frame input	Low
O_FRAME_B	Output	PCI frame output	Low
EN_FRAME	Output	PCI frame output enable output (Output buffer enable of O_FRAME_B)	High
I_IRDY_B	Input	PCI initiator ready input	Low
O_IRDY_B	Output	PCI initiator ready output	Low
EN_IRDY	Output	PCI initiator ready output enable output (Output buffer enable of O_IRDY_B)	High
I_DEVSEL_B	Input	PCI device select input	Low
O_DEVSEL_B	Output	PCI device select output	Low
EN_DEVSEL	Output	PCI device select output enable output (Output buffer enable of O_DEVSEL_B)	High
I_TRDY_B	Input	PCI target ready input	Low
O_TRDY_B	Output	PCI target ready output	Low
EN_TRDY	Output	PCI target ready output enable output (Output buffer enable of O_TRDY_B)	High
I_STOP_B	Input	PCI stop input	Low
O_STOP_B	Output	PCI stop output	Low
EN_STOP	Output	PCI stop output enable output (Output buffer enable of O_STOP_B)	High
I_PAR	Input	PCI parity input	–
O_PAR	Output	PCI parity output	–
EN_PAR	Output	PCI parity output enable output (Output buffer enable of O_PAR)	High
I_PERR_B	Input	PCI parity error input	Low
O_PERR_B	Output	PCI parity error output	Low
EN_PERR	Output	PCI parity error output enable output (Output buffer enable of O_PERR_B)	High
I_SERR_B	Input	PCI system error input	Low
I_REQ_B1 to I_REQ_B7	Input	PCI request input	Low
O_GNT_B1 to O_GNT_B7	Output	PCI grant output	Low

3.4 Registers

The registers of the PCI host bridge macro are listed below. The bit width of all registers is 32 bits.

The offset address of each register is the offset value from the base address in the area in which the I_CPU_CS0_B pin becomes active.

Offset Address	Register Name	R/W	Function
00H	PCI_CONFIG_DATA	R/W	PCI configuration register access data setting
04H	PCI_CONFIG_ADD	R/W	PCI configuration register access address setting
08H	PCI_CONTROL	R/W	PCI bus control
0CH	Reserved		
10H	PCI_IO_BASE	R/W	Sets base address of PCI bus I/O space accessed from PCI I/O area on CPU memory map
14H	PCI_MEM_BASE	R/W	Sets base address of PCI bus memory space accessed from PCI memory area on CPU memory map
18H	PCI_INT_CTL	R/W	PCI error interrupt control
1CH	PCI_ERR_ADD	R	PCI error generation address retention
20H to 3FH	Reserved		
40H	SYSTEM_MEM_BASE	R/W	Sets base address of system memory area mapped to PCI bus memory space
44H	SYSTEM_MEM_RANGE	R/W	Sets range of system memory area mapped to PCI bus memory space
48H	SDRAM_CTL	R/W	SDRAM access control
4CH to FFH	Reserved		

3.4.1 PCI_CONFIG_DATA register

After reset: Undefined R/W Offset address: 00H

31

0

CDATA

Bit Name	R/W	Function
CDATA	R/W	PCI configuration register write access is executed by writing data to this field, and the data written to this field is written to the access target register. PCI configuration register read access is executed by reading this field, and the data of the access target register is read.

3.4.2 PCI_CONFIG_ADD register

After reset: 00000000H R/W Offset address: 04H

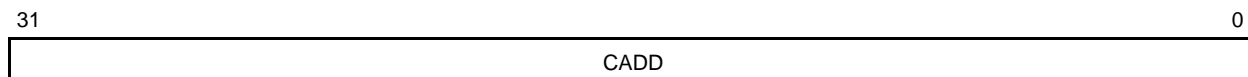

Bit Name	R/W	Function
CADD	R/W	Sets PCI configuration register address of access target.

(1) How to set PCI_CONFIG_ADD register

(a) Type 0 (PCI device)

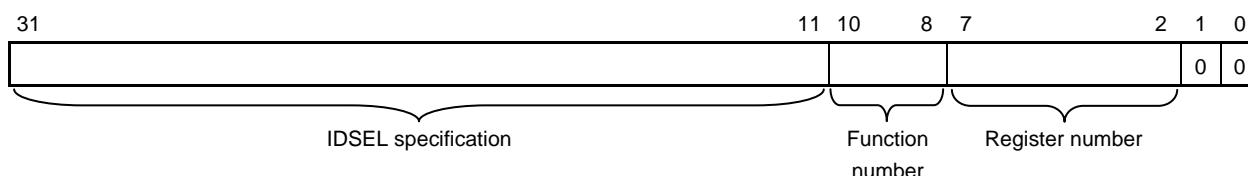

IDSEL specification: Selects the IDSEL signal corresponding to the access target PCI device. Because this PCI host bridge macro uses the AD31 to AD11 signals as the IDSEL signal for each PCI device, the AD signal connected to the IDSEL pin of each PCI device is specified in this field. For example, if the AD31 signal is connected to the IDSEL pin of a PCI device, access is enabled by setting bit 31 of CADD to 1.

Function number: Specifies the function number for a multifunction device.

Register number: Specifies the number of the access target PCI configuration register.

(b) Type 1 (PCI-PCI bridge)

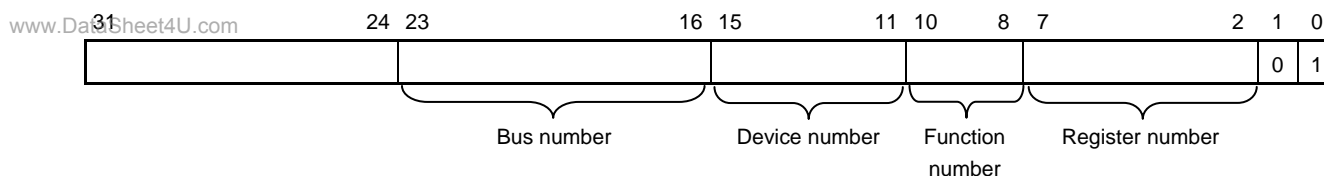

Bus number: Specifies the number of the PCI bus connected to the access target PCI device.

Device number: Specifies the device number of the access target PCI device.

Function number: Specifies the function number for a multifunction device.

Register number: Specifies the number of the access target PCI configuration register.

(2) How to access PCI configuration register

• Write access

Set the access target register address to the PCI_CONFIG_ADD register



Write the access target register setting value to the PCI_CONFIG_DATA register

• Read access

Set the access target register address to the PCI_CONFIG_ADD register



Read the PCI_CONFIG_DATA register

3.4.3 PCI_CONTROL register

After reset: 07000100H R/W Offset address: 08H

31	24	23							17	16	15			8	7		5	4	3	2	1	0
PCI_PARKCNT	0	0	0	0	0	0	0	0	PCI_BPMODE	PCI_REQ	0	0	0	PCI_RESET	0	TARGET_EN	MEM_EN	IO_EN				

Bit Name	R/W	Function
PCI_PARKCNT	R/W	Sets the time for shifting to bus parking. At the default value, bus parking is performed seven clocks after the bus status becomes IDLE. The counter is started when FRAME# = High and IRDY# = High.
PCI_BPMODE	R/W	Sets the bus parking master. 0: Limited to this macro 1: Master accessed last
PCI_REQ	R/W	Enables/disables the REQ# signal (I_REQ_B1 to I_REQ_B7 pins) from the bus master. Bit 0 of this field (bit 8 of the PCI_CONTROL register) is assigned to the PCI host bridge macro, and is always 1. 0: Disabled 1: Enabled
PCI_RESET	R/W	Sets the reset status of the PCI bus. 0: Reset status 1: Reset released
TARGET_EN	R/W	Sets the operation of the PCI bus target of the PCI host bridge macro. 0: Do not respond to main memory (SDRAM) access from the PCI device 1: Respond to main memory (SDRAM) access from the PCI device
MEM_EN	R/W	Enables/disables access from the CPU to the PCI memory area. 0: Access disabled 1: Access enabled
IO_EN	R/W	Enables/disables access from the CPU to the PCI I/O area. 0: Access disabled 1: Access enabled

3.4.4 PCI_IO_BASE register

When I/O accessing the PCI bus I/O space via the PCI I/O area (area in which the I_CPU_CS1_B pin becomes active: 64 KB), any area of the 4 GB PCI bus I/O space can be accessed by setting this register.

After reset: 00000000H R/W Offset address: 10H

31	16 15	0
IO_BASE	0 0 0 0 0 0 0 0 0 0 0 0 0 0 0 0	

Bit Name	R/W	Function
IO_BASE	R/W	Sets the higher 16 bits (bits 16 to 31) of the PCI bus I/O space base address when accessing the PCI I/O area (area in which the I_CPU_CS1_B pin becomes active) from the CPU.

3.4.5 PCI_MEM_BASE register

When memory accessing the PCI bus memory space via the PCI memory area (area in which the I_CPU_CS2_B pin becomes active: 1 MB), any area of the 4 GB PCI bus memory space can be accessed by setting this register.

However, because the main memory (SDRAM) is mapped on the PCI bus memory space, do not overlap the area set by the SYSTEM_MEM_BASE register and SYSTEM_MEM_RANGE register described later.

After reset: 80000000H R/W Offset address: 14H

31	20 19	0
M_BASE	0 0 0 0 0 0 0 0 0 0 0 0 0 0 0 0 0 0 0 0	

Bit Name	R/W	Function
M_BASE	R/W	Sets the higher 12 bits (bits 20 to 31) of the PCI bus memory space base address when accessing the PCI memory area (area in which the I_CPU_CS2_B pin becomes active) from the CPU.

3.4.6 PCI_INT_CTL register

The PCI_INT_CTL register shows the interrupt sources of the PCI bus error interrupt (O_PCIHOST_INT) and controls masking and clearing of these interrupts.

This function is used only for debugging and is not used in normal operation.

After reset: 000x0F00H R/W Offset address: 18H

31												20	19	18	17	16	15					12	11	10	9	8	7				4	3	2	1	0
0	0	0	0	0	0	0	0	0	0	0	0	0	CLR_SERR	CLR_PERR	CLR_MAB	CLR_TAB	0	0	0	0	MSK_SERR	MSK_PERR	MSK_MAB	MSK_TAB	0	0	0	0	SERR	PERR	MABORT	TABORT			

Bit Name	R/W	Function
CLR_SERR	W	Clears the PCI bus system error (SERR# reception) interrupt. 1: Cleared
CLR_PERR	W	Clears the PCI bus parity error (PERR# reception) interrupt. 1: Cleared
CLR_MAB	W	Clears the PCI bus master abort interrupt. 1: Cleared
CLR_TAB	W	Clears the PCI bus target abort interrupt. 1: Cleared
MSK_SERR	R/W	Sets the mask status of the PCI bus system error (SERR# reception) interrupt. 0: Not masked 1: Masked
MSK_PERR	R/W	Sets the mask status of the PCI bus parity error (PERR# reception) interrupt. 0: Not masked 1: Masked
MSK_MAB	R/W	Sets the mask status of the PCI bus master abort interrupt. 0: Not masked 1: Masked
MSK_TAB	R/W	Sets the mask status of the PCI bus target abort interrupt. 0: Not masked 1: Masked
SERR	R	Detects the occurrence status of a PCI bus system error (SERR# reception). 1: System error occurred
PERR	R	Detects the occurrence status of the PCI bus parity error (PERR# reception). 1: Parity error occurred
MABORT	R	Detects the occurrence status of the PCI bus master abort. 1: Master abort occurred
TABORT	R	Detects the occurrence status of the PCI bus target abort. 1: Target abort occurred

3.4.7 PCI_ERR_ADD register

The PCI_ERR_ADD register retains the PCI bus address when the following errors occur.

- System error (SERR# reception)
- Parity error (PERR# reception)
- Master abort
- Target abort

When the PCI_ERR_ADD register is read, all the bits are cleared. Once an error occurs and a value is set to the PCI_ERR_ADD register, the first value is retained until read access is performed or a new error occurs and the value is updated.

This function is used only for debugging and is not used in normal operation.

After reset: 00000000H R Offset address: 1CH

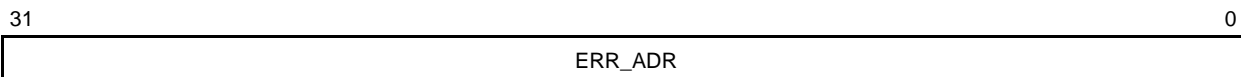

Bit Name	R/W	Function
ERR_ADR	R	Retains the address when a PCI bus error occurs.

3.4.8 SYSTEM_MEM_BASE register

When the main memory is accessed from the PCI device by setting the SYSTEM_MEM_BASE register and SYSTEM_MEM_RANGE register, the register responds to an access of a matching address.

After reset: 00000000H R/W Offset address: 40H

31	16 15	0
S_BASE		0 0 0 0 0 0 0 0 0 0 0 0 0 0 0 0

Bit Name	R/W	Function
S_BASE	R/W	Sets the higher 16 bits (bits 16 to 31) of the base address on the PCI bus memory space in which the main memory (SDRAM) is mapped.

3.4.9 SYSTEM_MEM_RANGE register

After reset: 0000FFFFH R/W Offset address: 44H

31	16 15	0
S_RANGE		1 1 1 1 1 1 1 1 1 1 1 1 1 1 1 1

Bit Name	R/W	Function
S_RANGE	R/W	<p>Sets the range of the PCI bus memory space in which the main memory (SDRAM) is mapped. It can be set in 64 KB units.</p> <p>0000H: 64 KB 0001H: 128 KB : 000FH: 1 MB : 00FFH: 16 MB : 0FFFH: 256 MB : FFFFH: 4 GB</p>

3.4.10 SDRAM_CTL register

After reset: 00070230H R/W Offset address: 48H

31										24	23				16	15				13	12	11	10	9	8	7	6	5	4	3	2	1	0		
0	0	0	0	0	0	0	0	0	0																										
CYCLE_LATENCY										0	0	0	BUS_SIZE	0	0	CAS_LATENCY	0	0	WAIT_STATE	0	0	COLUMN_SIZE													

Bit Name	R/W	Function
CYCLE_LATENCY	R/W	Sets the latency for successive main memory (SDRAM) accesses from the PCI device. A latency of up to 7,650 ns can be set. 00H: No latency 01H: 1 PCI clock (30 ns) : FFH: 255 PCI clocks (7,650 ns)
BUS_SIZE	R/W	Sets the bit width of the data bus. 0: 16-bit width 1: 32-bit width
CAS_LATENCY	R/W	Sets the CAS latency. 00: Setting prohibited 01: 1 10: 2 11: 3
WAIT_STATE	R/W	Sets the wait interval of ACT → CMD, PRE → ACT, and CMD → ACT. 00: Setting prohibited 01: 1 clock 10: 2 clocks 11: 3 clocks
COLUMN_SIZE	R/W	Sets the bit width of the column address. 00: 8-bit width 01: 9-bit width 10: 10-bit width 11: 11-bit width

The correspondence between the output address signals when the main memory (SDRAM) is accessed and the PCI bus address signals is shown below.

Table 3-1. Row Address Output

COLUMN_SIZE Field Setting Value	Correspondence Between PCI Bus Address Signal and Main Memory (SDRAM) Address Pins (O_SD_ADR1 to O_SD_ADR25)																	
	25 to 18	17	16	15	14	13	12	11	10	9	8	7	6	5	4	3	2	1
00 (8 bits)	25 to 18	25	24	23	22	21	20	19	18	17	16	15	14	13	12	11	10	9
01 (9 bits)	25 to 18	17	25	24	23	22	21	20	19	18	17	16	15	14	13	12	11	10
10 (10 bits)	25 to 18	17	16	25	24	23	22	21	20	19	18	17	16	15	14	13	12	11
11 (11 bits)	25 to 18	17	16	15	25	24	23	22	21	20	19	18	17	16	15	14	13	12

Table 3-2. Column Address Output (Precharge Command)

BUS_SIZE Bit Setting Value	Correspondence Between PCI Bus Address Signal and Main Memory (SDRAM) Address Pins (O_SD_ADR1 to O_SD_ADR25)																	
	25 to 18	17	16	15	14	13	12	11	10	9	8	7	6	5	4	3	2	1
0 (16 bits)	25 to 18	17	16	15	14	12	11	H	10	9	8	7	6	5	4	3	2	1
1 (32 bits)	25 to 18	17	16	15	14	12	H	11	10	9	8	7	6	5	4	3	2	1

Remark H: High level

Table 3-3. Column Address Output (Read/Write Command)

BUS_SIZE Bit Setting Value	Correspondence Between PCI Bus Address Signal and Main Memory (SDRAM) Address Pins (O_SD_ADR1 to O_SD_ADR25)																	
	25 to 18	17	16	15	14	13	12	11	10	9	8	7	6	5	4	3	2	1
0 (16 bits)	25 to 18	17	16	15	14	12	11	L	10	9	8	7	6	5	4	3	2	1
1 (32 bits)	25 to 18	17	16	15	14	12	L	11	10	9	8	7	6	5	4	3	2	1

Remark L: Low level

3.5 Address Map

The address maps of the CPU memory space and PCI bus I/O or memory space are shown below.

Figure 3-3. CPU Memory Space/PCI Bus I/O Space Address Map

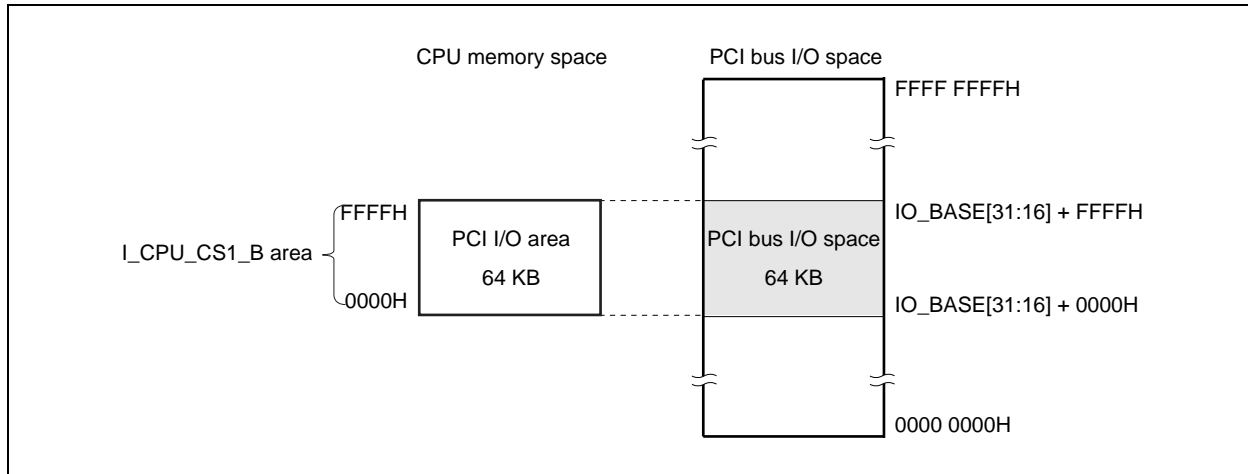
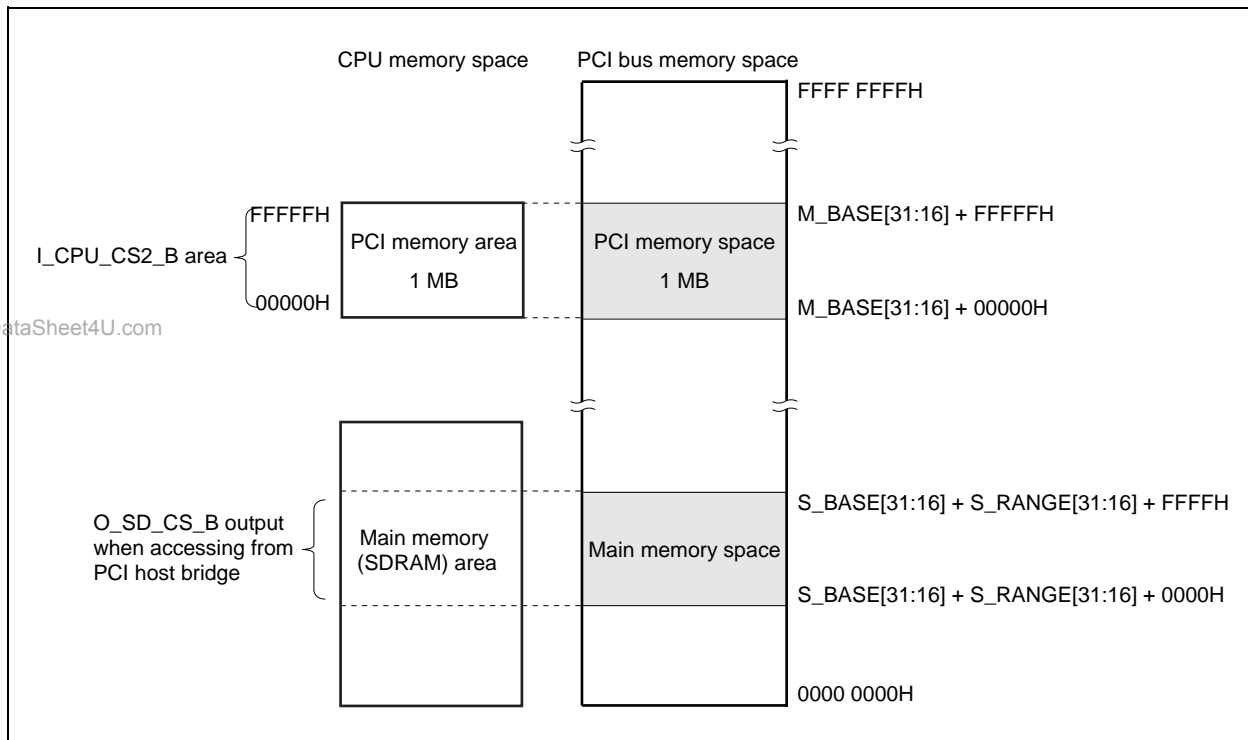

Figure 3-4. CPU Memory Space/PCI Bus Memory Space Address Map



3.6 Initializing PCI Host Bridge Macro

The PCI host bridge macro must be initialized according to the following procedure to acknowledge memory access and I/O access to the PCI bus and main memory (SDRAM) access from the PCI device.

Figure 3-5. Initializing PCI Host Bridge Macro

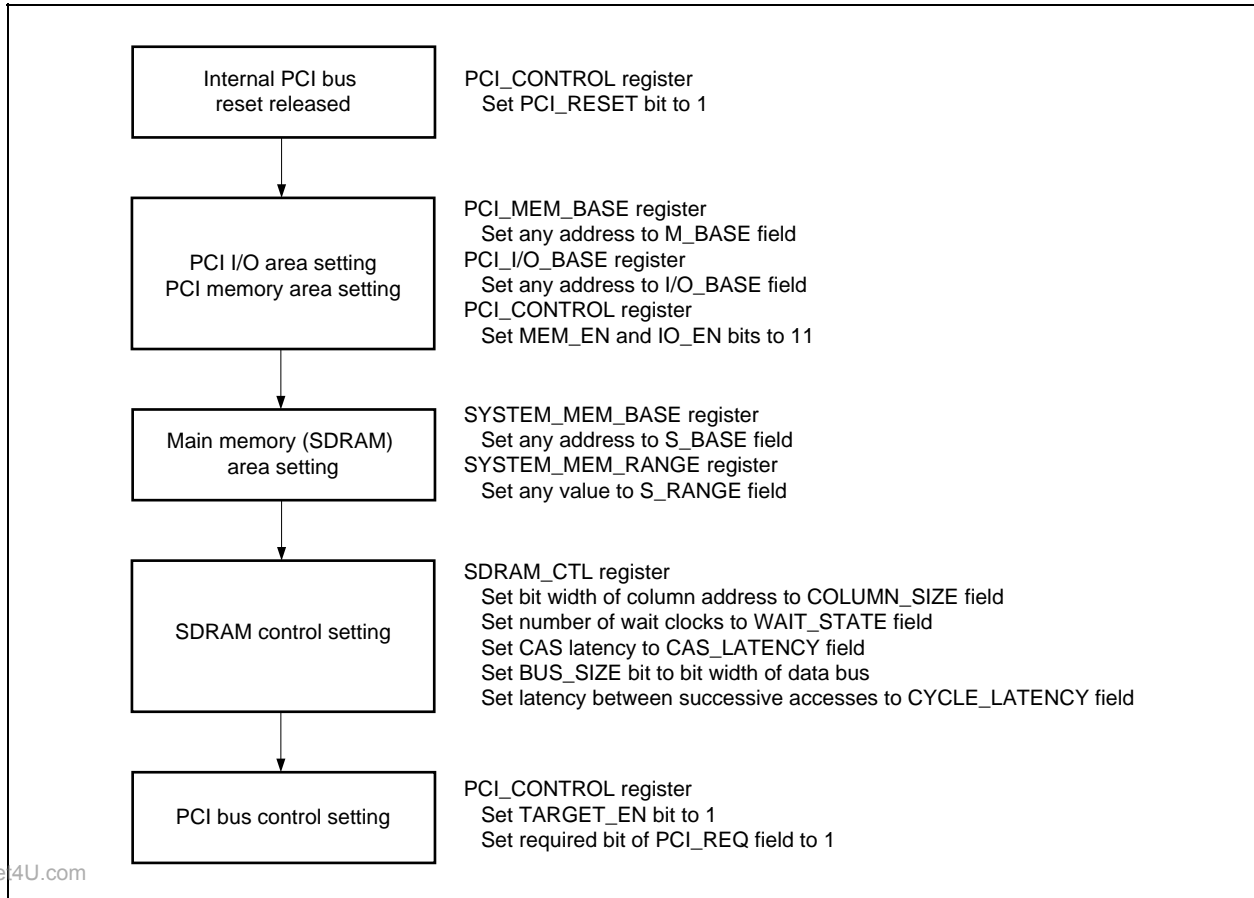

3.7 Bus Width of External Bus Interface

The operation mode of the data bus with respect to the external bus interface can be changed via the I_MODE16 pin status.

- Cautions**
1. Do not change the status of the I_MODE16 pin during operation.
 2. The I_MODE16 pin can only be used to change the operation mode of the data bus with respect to the external bus slave interface.
To change the data bus width of the SDRAM bus interface, use the BUS_SIZE bit in 3.4.10 SDRAM_CTL register.
 3. The setting of the I_MODE16 pin should correspond with the external bus interface operation mode of the CPU.
 4. When 16-bit mode is set, the access cycle is divided for 32-bit access on the external bus interface. Accordingly, access is divided similarly on the PCI bus interface. Therefore, when 16-bit mode is set, because a 32-bit access cycle is not generated on the PCI bus interface, a PCI device whose registers are only valid for 32-bit access cannot be accessed.

Table 3-4. I_MODE16 Pin Status and Operation Mode of Data Bus

I_MODE16 Pin	Data Bus Operation Mode	Remark
Low level	32-bit mode	32-bit data bus
High level	16-bit mode	16-bit data bus

3.8 Timing

The timing for each interface of the PCI host bridge macro is shown below.

3.8.1 External bus interface timing

CPU write/CPU read access is performed from the CPU using the bus interface (Figures 3-6 and 3-7).

When accessing SDRAM from the PCI host bridge macro, bus hold is performed and the main memory is write/read accessed (Figures 3-8 to 3-10).

Figure 3-6. CPU Write Access

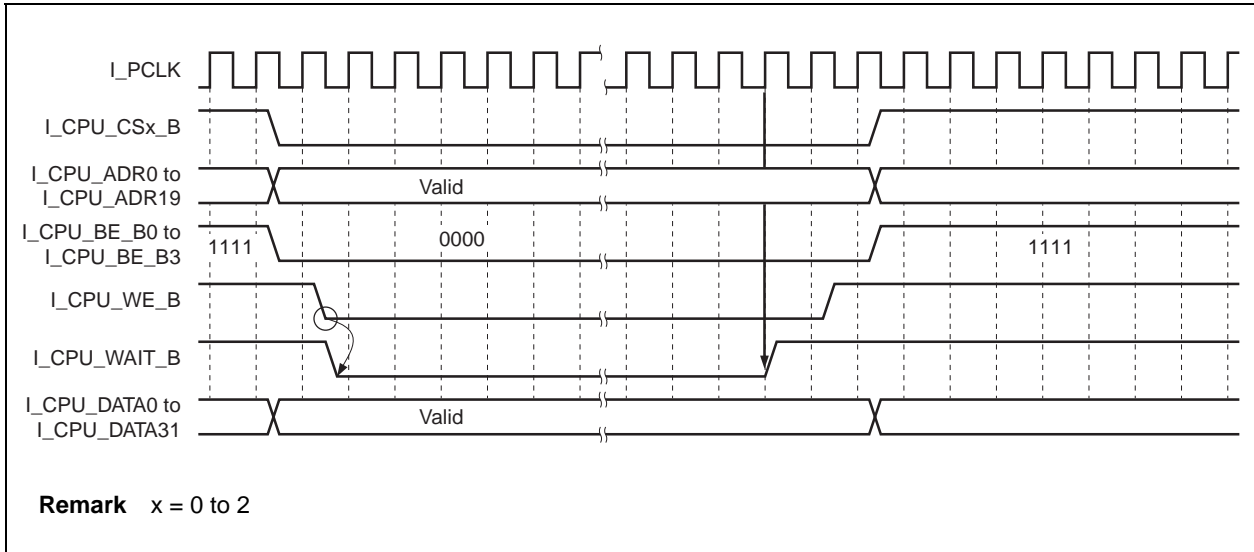

Figure 3-7. CPU Read Access

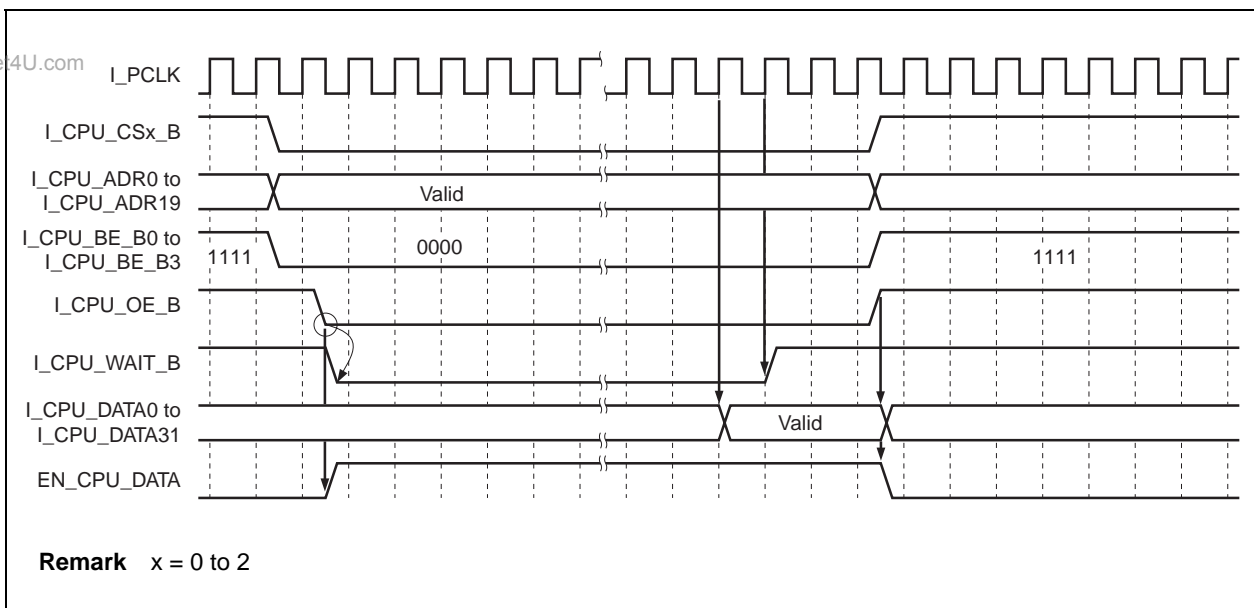

Figure 3-8. Hold Request/Hold Acknowledge

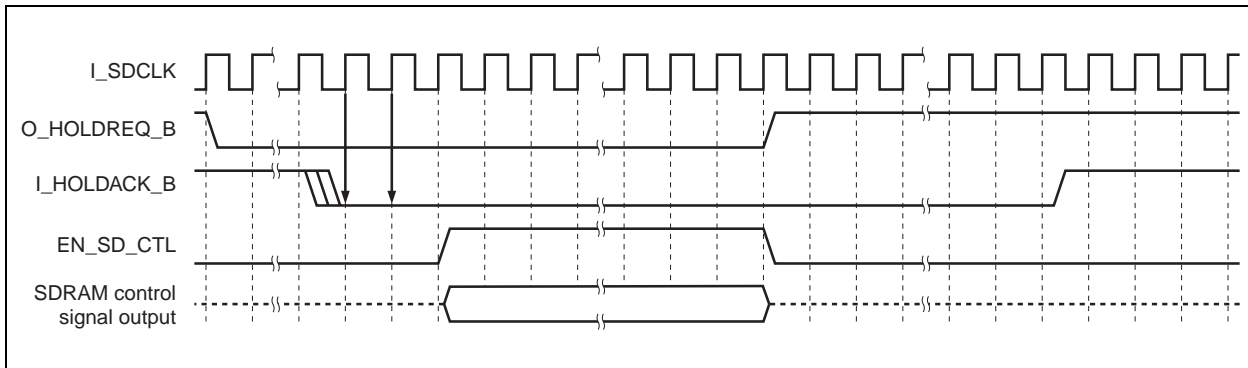

Figure 3-9. Main Memory (SDRAM) Write Access (8-Burst)

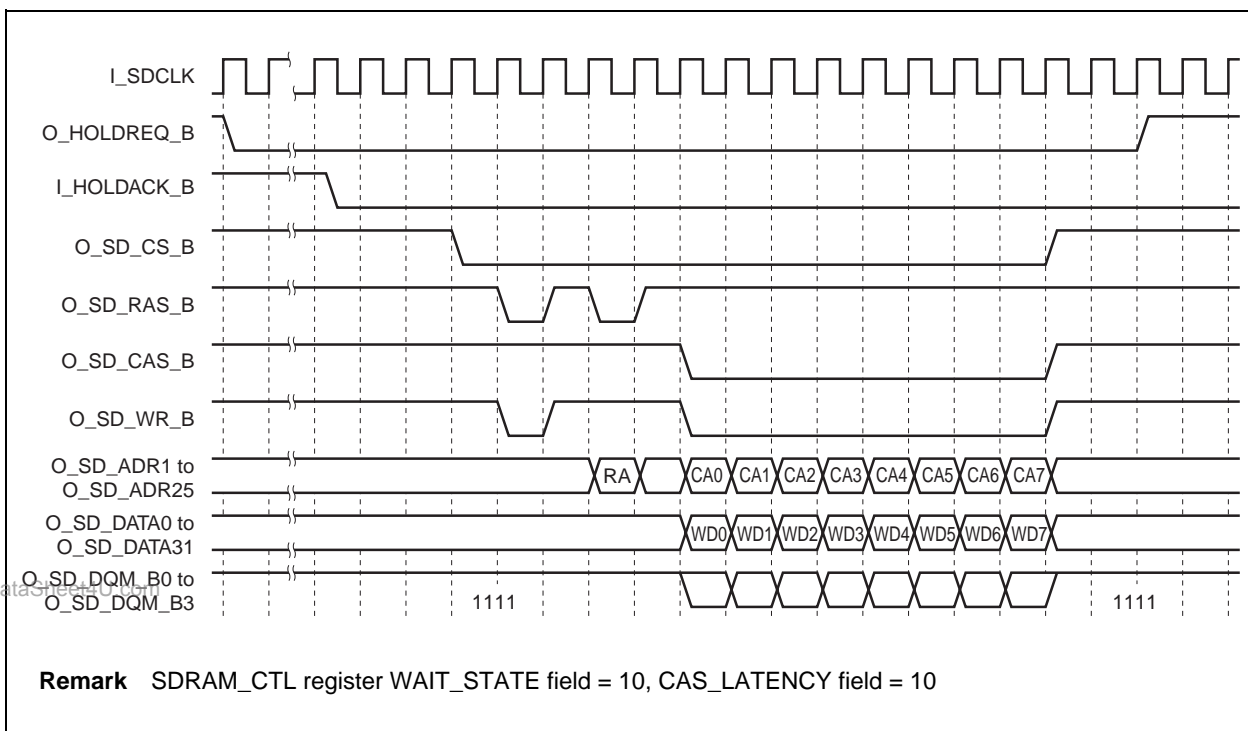
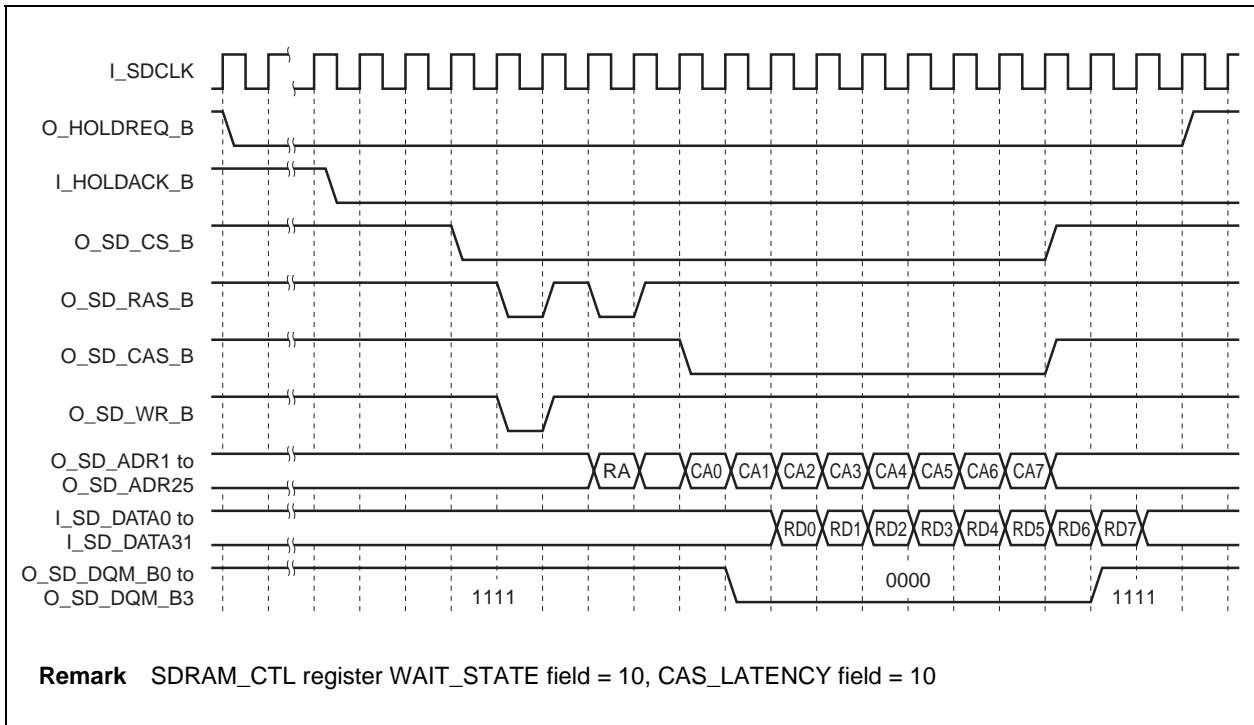

Figure 3-10. Main Memory (SDRAM) Read Access (8-Burst)



3.8.2 PCI bus interface timing

The PCI host bridge macro supports the following PCI bus interface timing.

(1) PCI bus master cycle timing

The timing of access from the CPU to the PCI device is shown below.

(a) Configuration read/write cycle, I/O read/write cycle, and memory read/write cycle

(i) Read cycle

Timing type: Configuration register read, internal I/O register read, memory read

Figure 3-11. Read Cycle

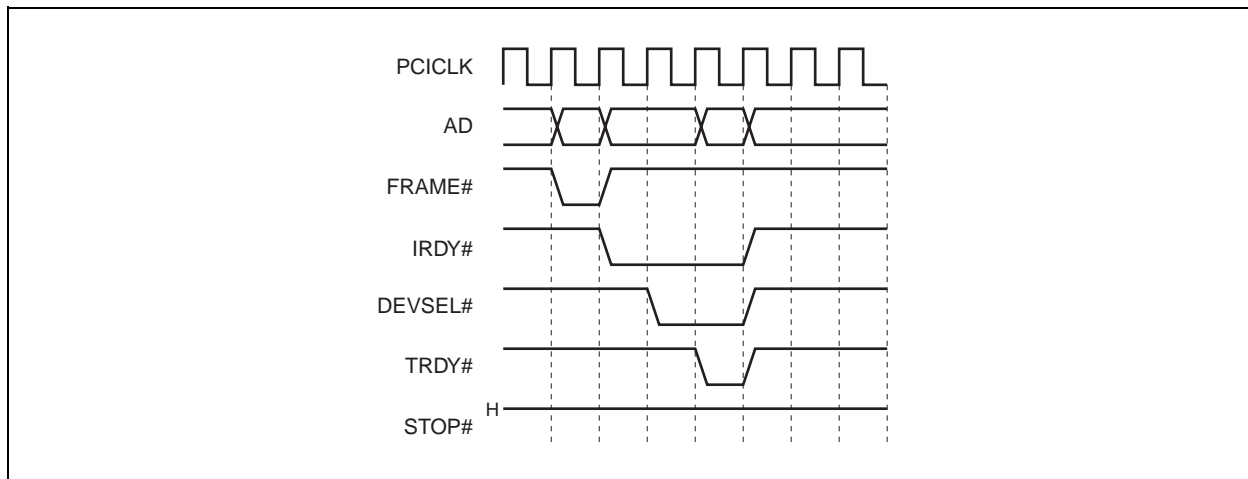

(ii) Write cycle

Timing type: Configuration register write, internal I/O register write, memory write

www.DataSheet4U.com

Figure 3-12. Write Cycle

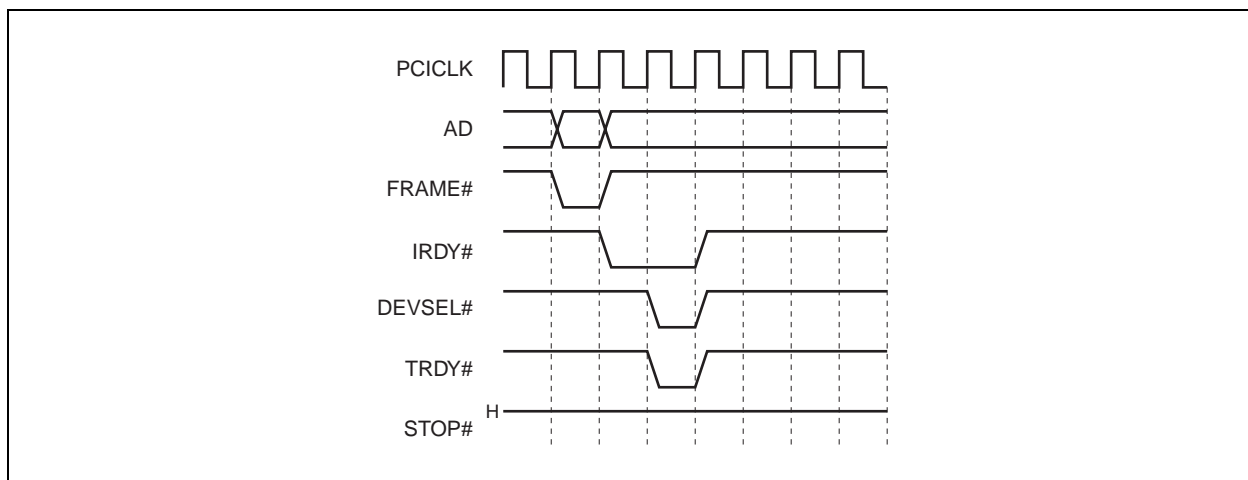

(b) Target abort cycle

Timing type: Target abort

Figure 3-13. Target Abort Cycle

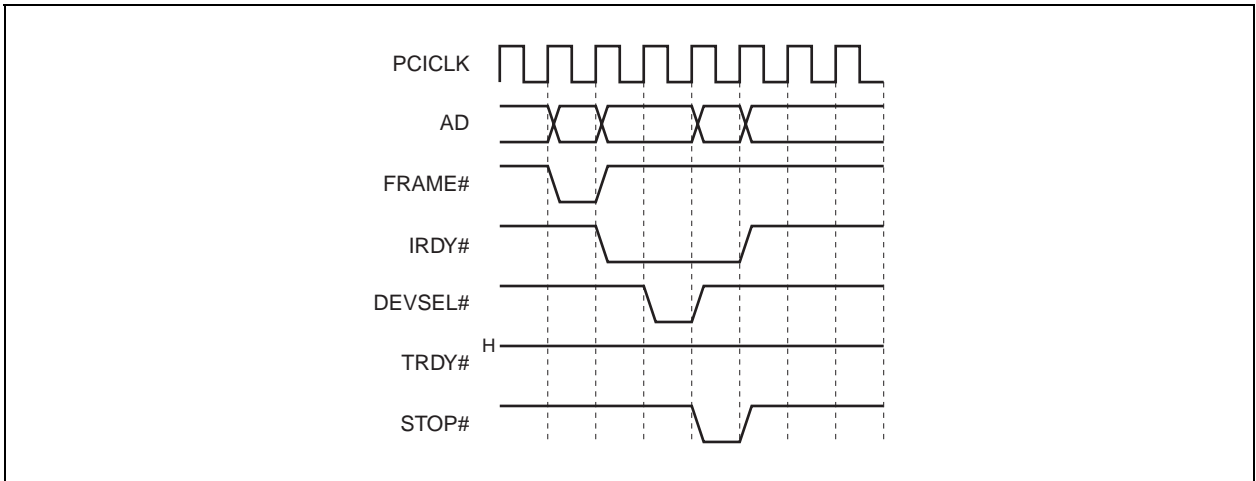

(c) Master abort cycle

Timing type: Master abort cycle

Figure 3-14. Master Abort Cycle

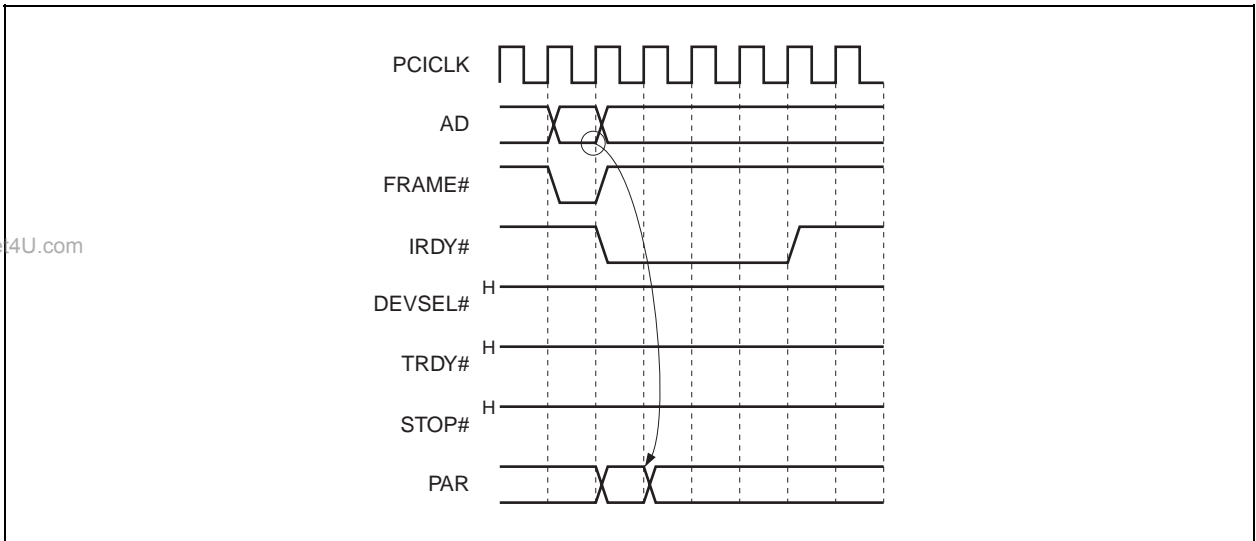

www.DataSheet4U.com

(d) Data parity error

Timing type: Single read & write cycle data parity error

Figure 3-15. Data Parity Error

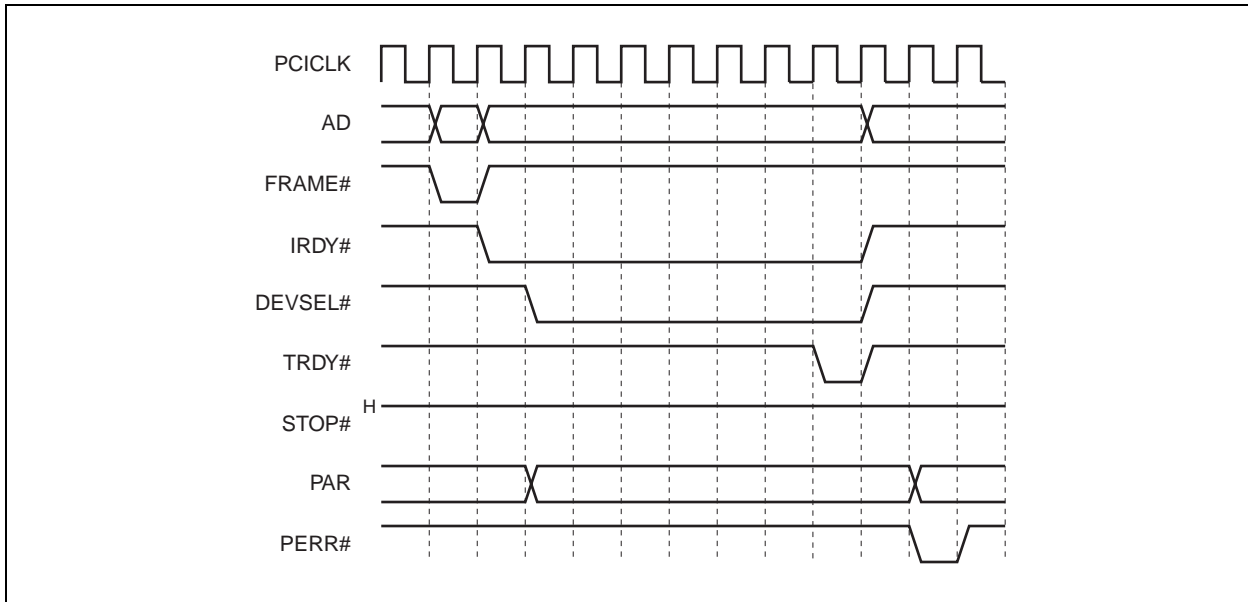

(2) PCI bus slave cycle timing

The timing of access from the PCI device to SDRAM is shown below.

(a) Memory single read cycle

Timing type: Memory single read cycle

Figure 3-16. Single Read Cycle

www.DataSheet4U.com

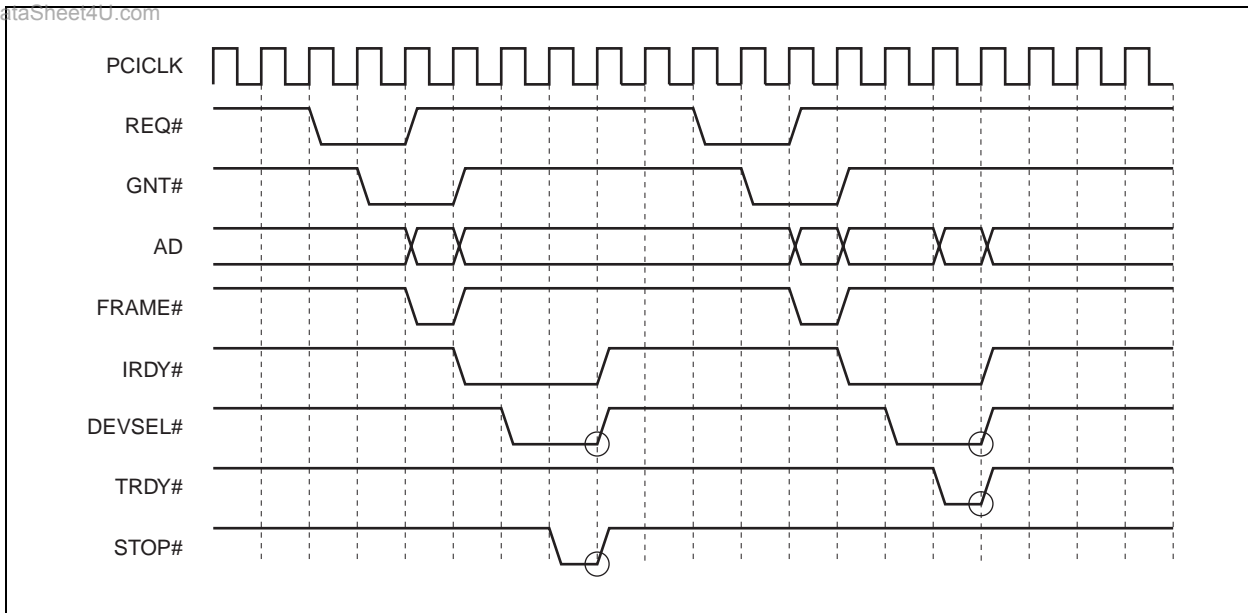

(b) Memory single write cycle

Timing type: Memory single write cycle

Figure 3-17. Single Write Cycle

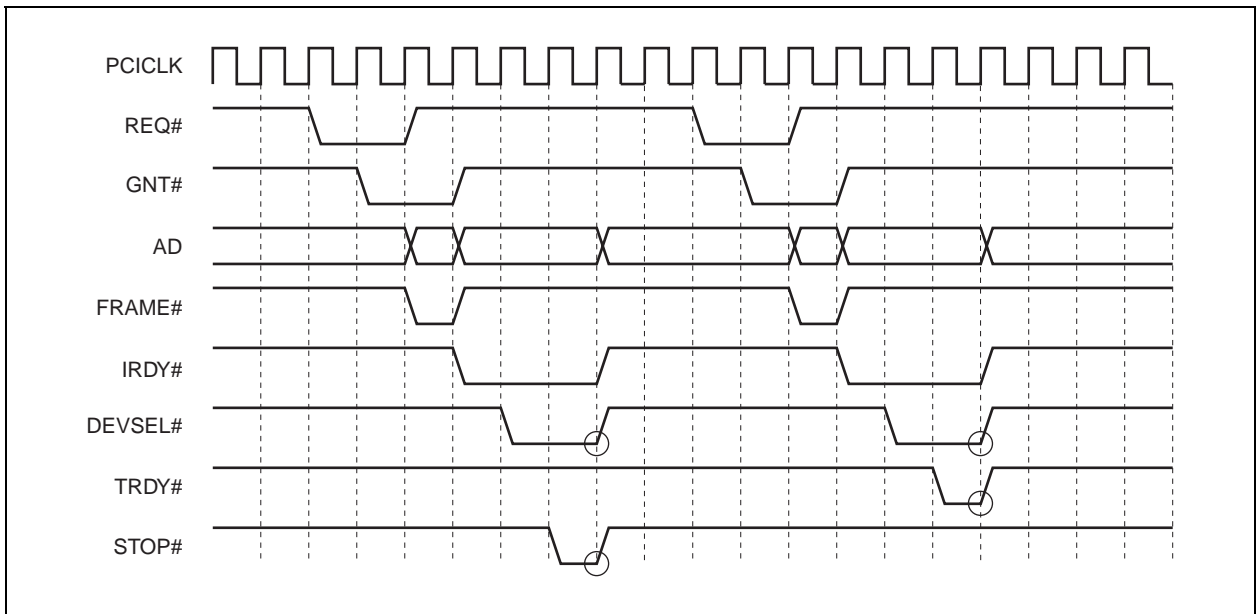

(c) Burst read cycle

Timing type: Memory burst read cycle – Not disconnect

Figure 3-18. Burst Read Cycle

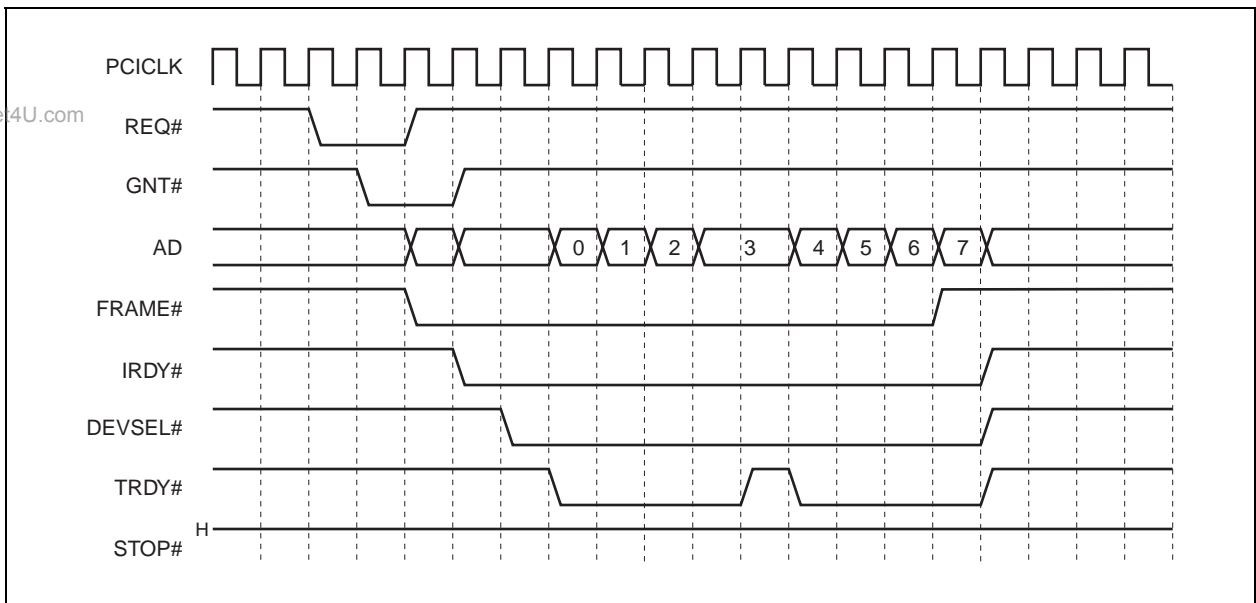

(d) Burst write cycle

Timing type: Memory burst write cycle – Not disconnect

Figure 3-19. Burst Write Cycle

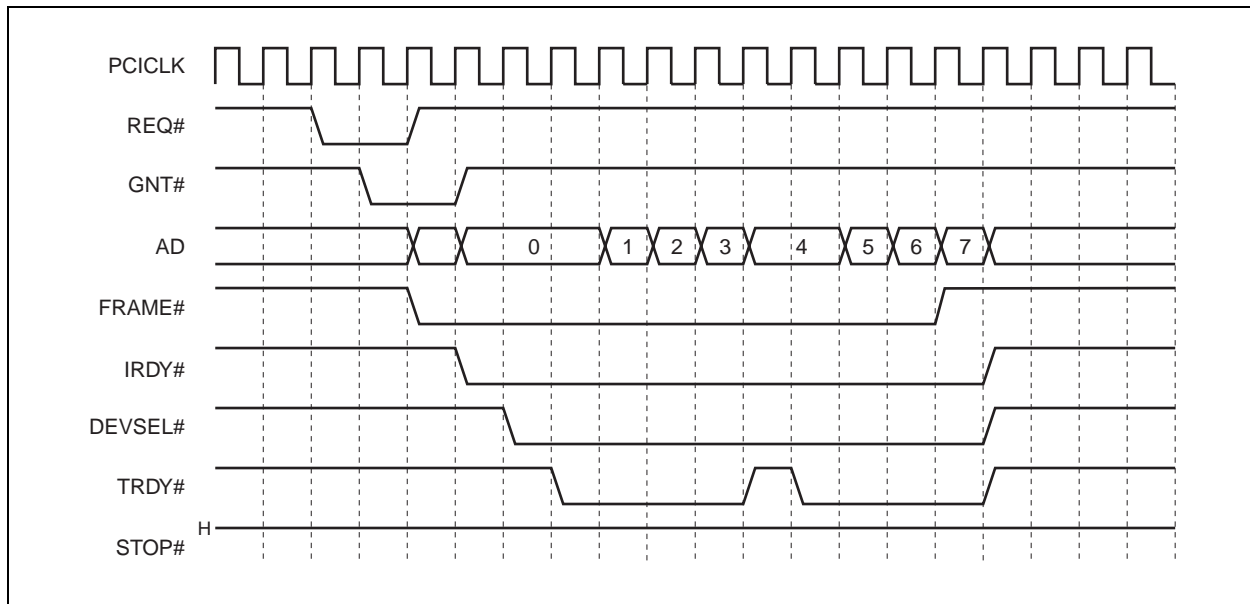

(e) Abort cycle

Timing type: Target abort cycle & master abort cycle

Figure 3-20. Abort Cycle

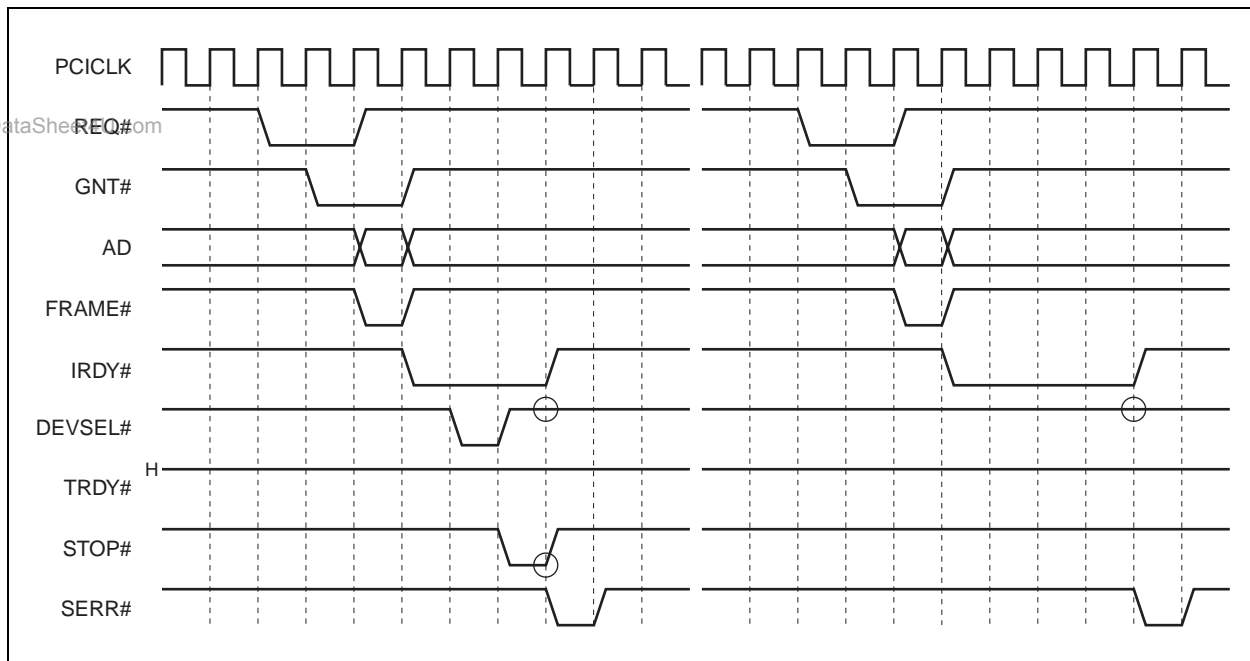

(f) Data parity error

(i) Read data parity error 1

Timing type: Single read cycle data parity error

Figure 3-21. Read Data Parity Error

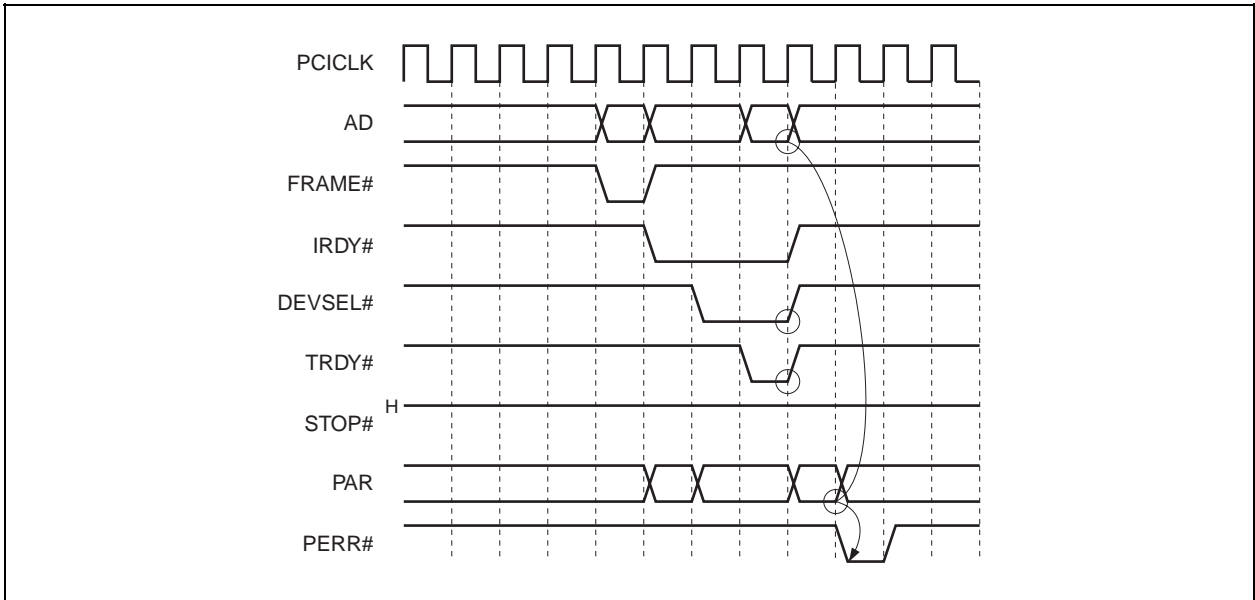

(ii) Read data parity error 2

Timing type: Burst read cycle data parity error

Figure 3-22. Read Data Parity Error 2

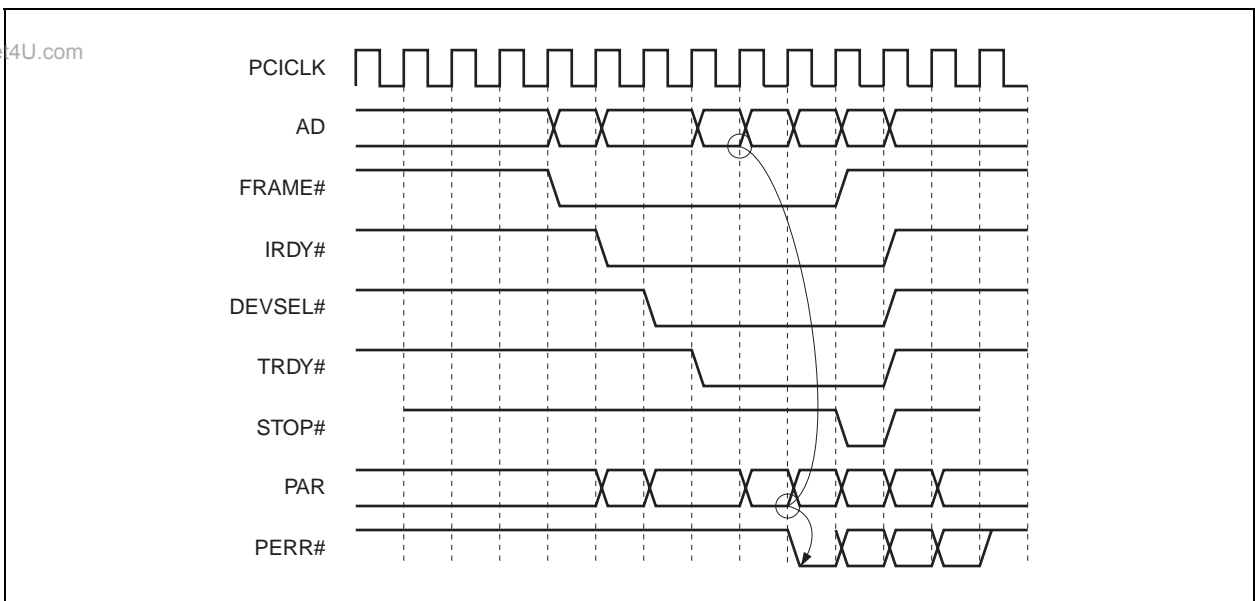

(iii) Write data parity error 1

Timing type: Single write cycle data parity error

Figure 3-23. Write Data Parity Error 1

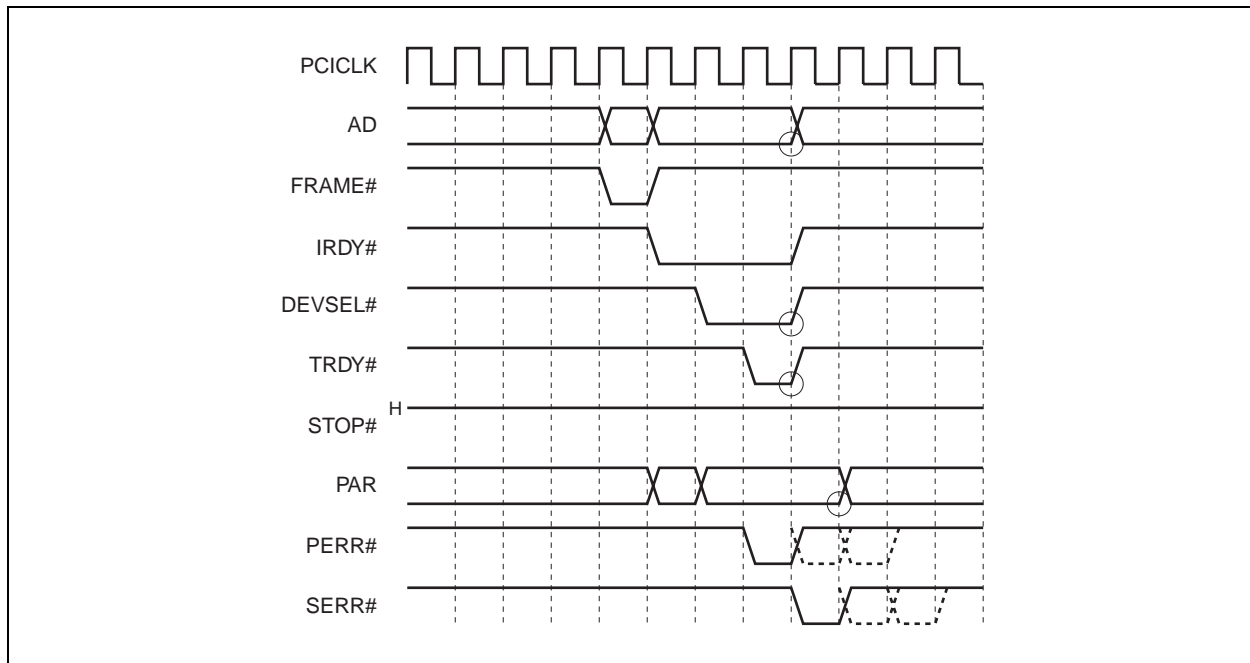

(iv) Write data parity error 2

Timing type: Burst write cycle data parity error

Figure 3-24. Write Data Parity Error 2

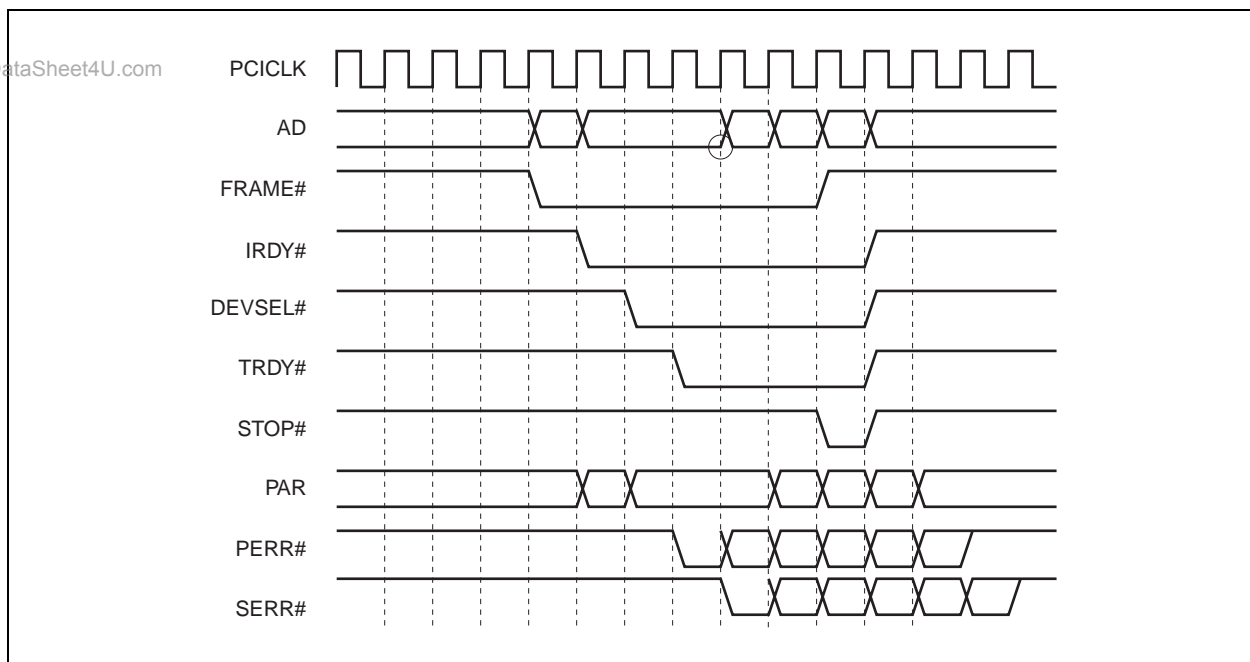

CHAPTER 4 CONFIGURATION EXAMPLES OF FPGA INTEGRATION

This chapter describes configuration examples in which the PCI host bridge macro is integrated in an FPGA (Altera's EP20K200EQC240-1X).

4.1 Conditions for Configuration Examples of FPGA Integration

The conditions in the configuration examples are as follows.

- | | |
|--|--|
| (1) CPU: | V850E/ME2 |
| (2) Bus width of external bus interface: | 32 bits |
| (3) CS space of PCI host bridge: | CSZ6 |
| (4) CS space of SDRAM: | CSZ3 |
| (5) SDRAM: | Connecting two 16 M × 16 SDRAMs (4 M × 16 × 4 banks) |
| (6) PCI connection: | 2 devices |

4.2 Points to Remember When Creating Top Layer of FPGA

Points to remember when integrating the PCI host bridge macro with an FPGA are indicated below.

- (1) First decode the chip select from the address before creation.
 - I_CPU_CS0_B: PCI host bridge register chip select
(Offset address in **3.4 Registers**)
 - I_CPU_CS1_B: PCI I/O area chip select
(See **Figure 3-3 CPU Memory Space/PCI Bus I/O Space Address Map**)
 - I_CPU_CS2_B: PCI memory area chip select
(See **Figure 3-4 CPU Memory Space/PCI Bus Memory Space Address Map**)
- (2) Because the buffers of the address bus and data bus for the expansion bus interface are output when the PCI host bridge controls SDRAM, they become bidirectional pins via the selector.
The following pins that control SDRAM become 3-state output.
 - DQM0 to DQM3, SDCKE, SDCKS, SDRAS, SDCAS, SDWEZ
- (3) The following PCI bus interface pins become bidirectional pins.
 - AD, CBE, FRAME, IRDY, DEVSEL, TRDY, STOP, PAR, PERR
- (4) There are three interrupt request output signals: one is output from the PCI host bridge; the remaining two are INTA and INTB signals from the external PCI slot and are directly connected to the CPU.

4.3 Reference Diagram for FPGA Top Connection

The reference diagram for connecting the PCI host bridge macro with the FPGA top layer is shown below.

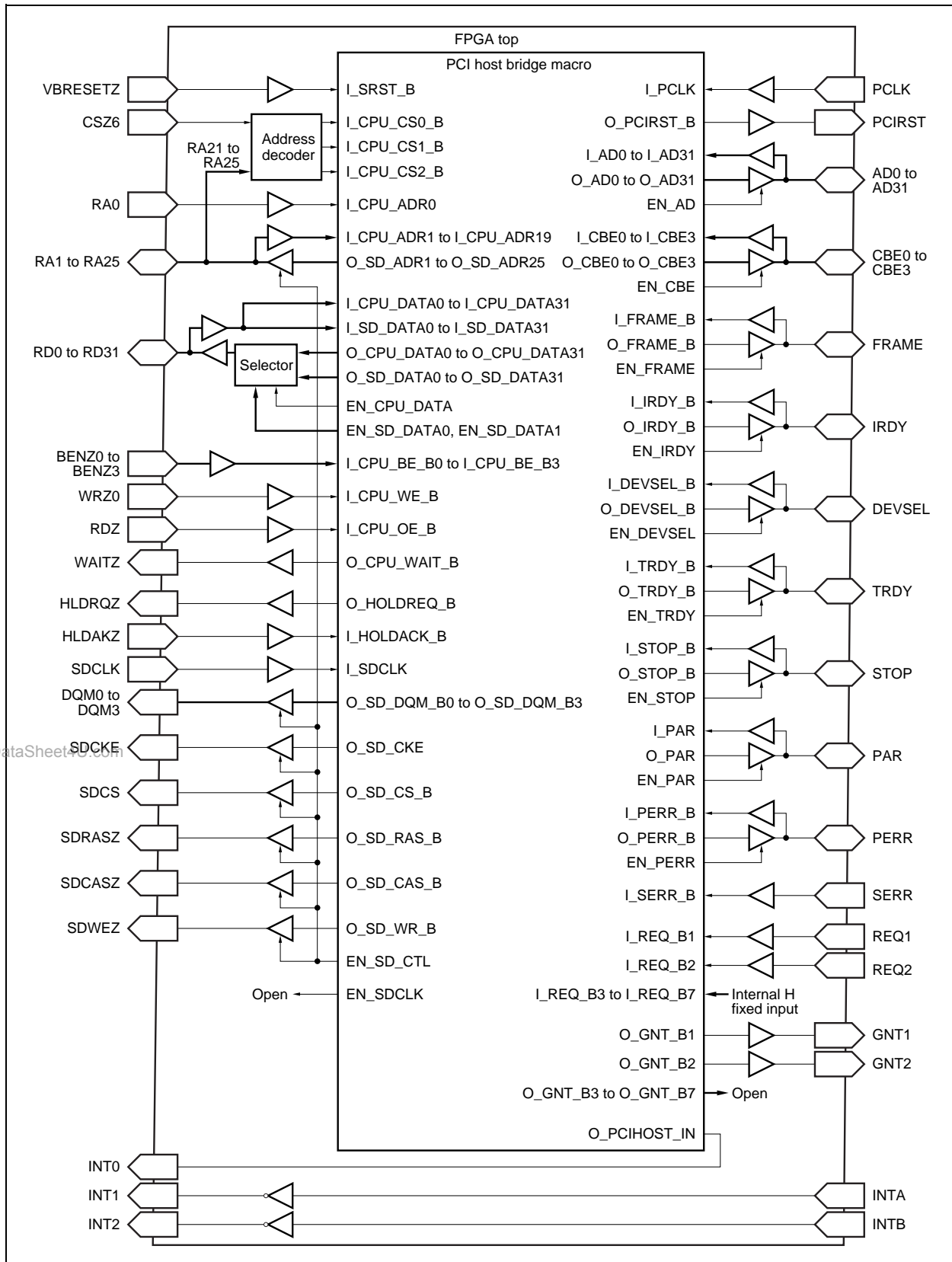

4.4 FPGA Top Pin Functions

The pin information when integrating the PCI host bridge macro with an FPGA is shown below.

4.4.1 CPU bus slave interface pins

Pin Name	I/O	Function
VBRESETZ	Input	System reset input
CSZ6	Input	PCI host bridge chip select input
RA0 to RA25	I/O	CPU address I/O
RD0 to RD31	I/O	CPU data I/O
BENZ0 to BENZ3	Input	CPU data byte enable input
WRZ	Input	CPU data write enable input
RDZ	Input	CPU data read enable input
WAITZ	Output	CPU data wait output
INT0	Output	PCI host bridge interrupt output

4.4.2 SDRAM bus interface pins

Pin Name	I/O	Function
HLDREQZ	Output	SDRAM bus hold request output
HLDAKZ	Input	SDRAM bus hold acknowledge input
SDCLK	Input	SDRAM clock input
SDCKE	Output	SDRAM clock enable output
SDCS	Output	SDRAM chip select output
SDRASZ	Output	SDRAM row address strobe output
SDCASZ	Output	SDRAM column address strobe output
SDWEZ	Output	SDRAM read/write output
DQM0 to DQM3	Output	SDRAM output disable output

4.4.3 PCI bus interface pins

Pin Name	I/O	Function
PCLK	Input	PCI clock input
PCIRST	Output	PCI reset output
AD0 to AD31	I/O	PCI address/data I/O
CBE0 to CBE3	I/O	PCI command/byte enable I/O
FRAME	I/O	PCI frame I/O
IRDY	I/O	PCI initiator ready I/O
DEVSEL	I/O	PCI device select I/O
TRDY	I/O	PCI target ready I/O
STOP	I/O	PCI stop I/O
PAR	I/O	PCI parity I/O
PERR	I/O	PCI parity error I/O
SERR	Input	PCI system error input
REQ1, REQ2	Input	PCI request input
GNT1, GNT2	Output	PCI grant output
INT1, INT2	Output	PCI INTA, INTB output

4.5 FPGA Top Pin Configuration

The connection diagram of the PCI host bridge macro pins in an FPGA is shown below.

4.5.1 Internal connection diagram of external bus interface

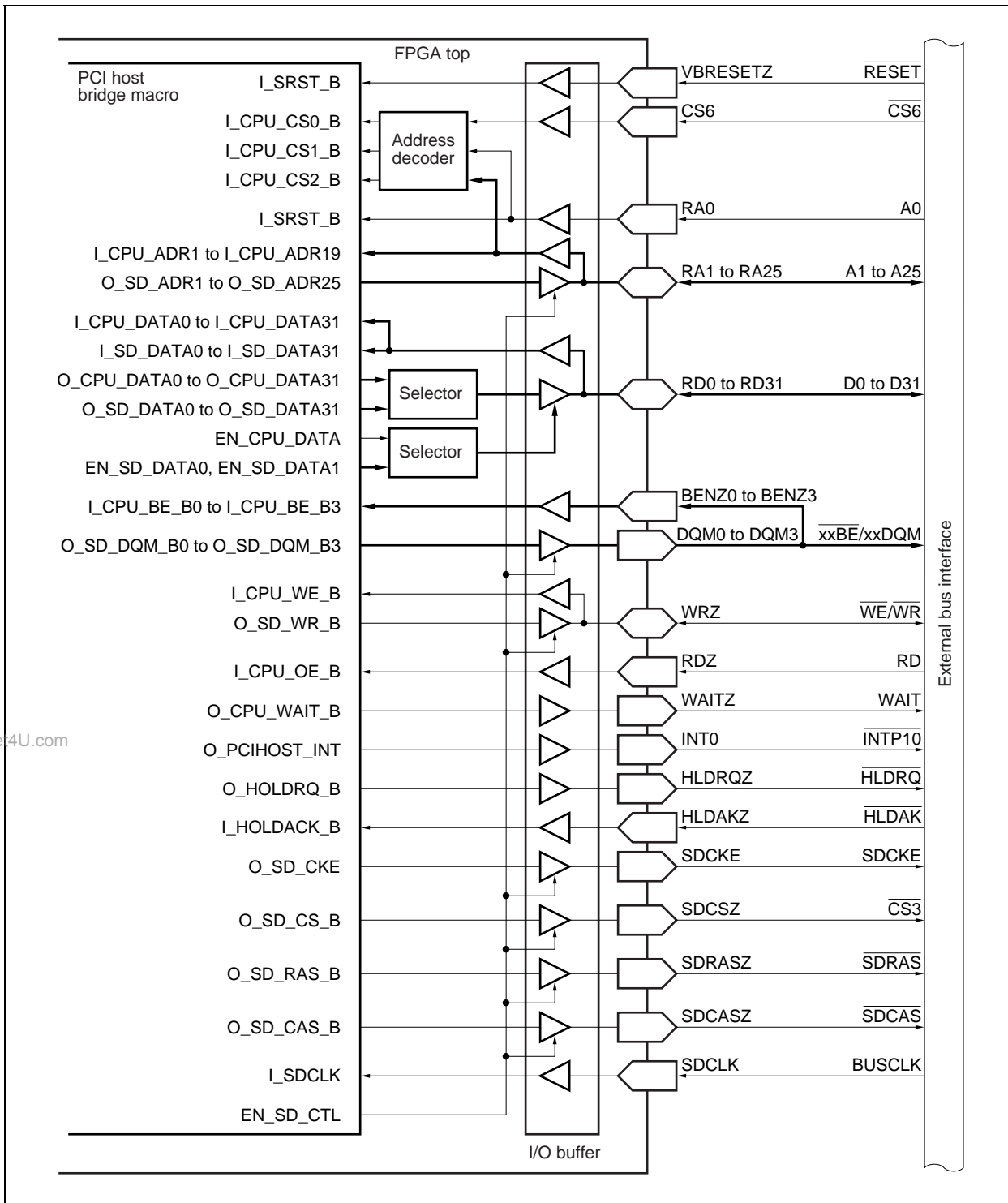

www.DataSheet4U.com

4.5.2 Internal connection diagram of PCI bus interface

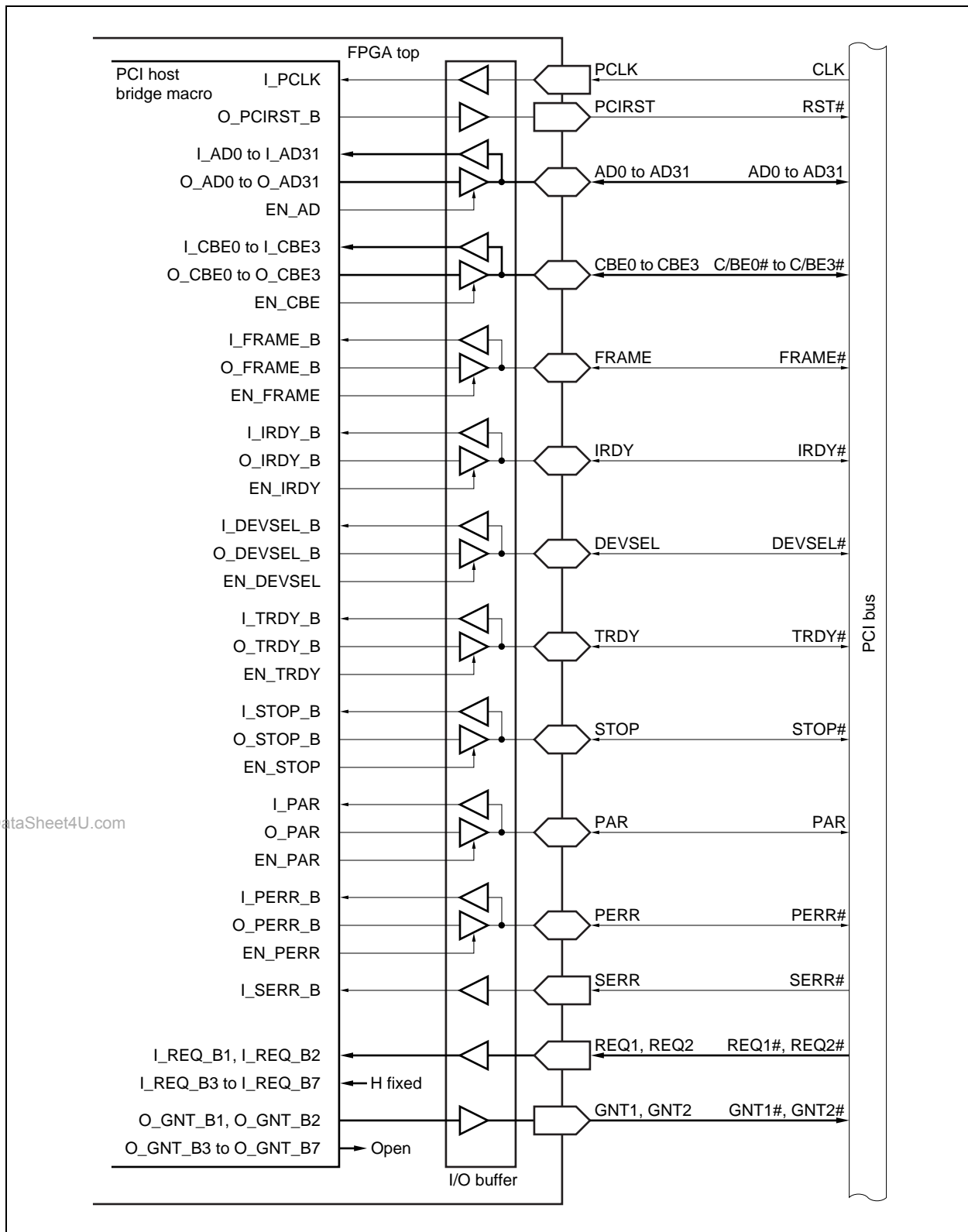

www.DataSheet4U.com

4.5.3 External connection diagram of external bus interface (example of connection with V850E/ME2)

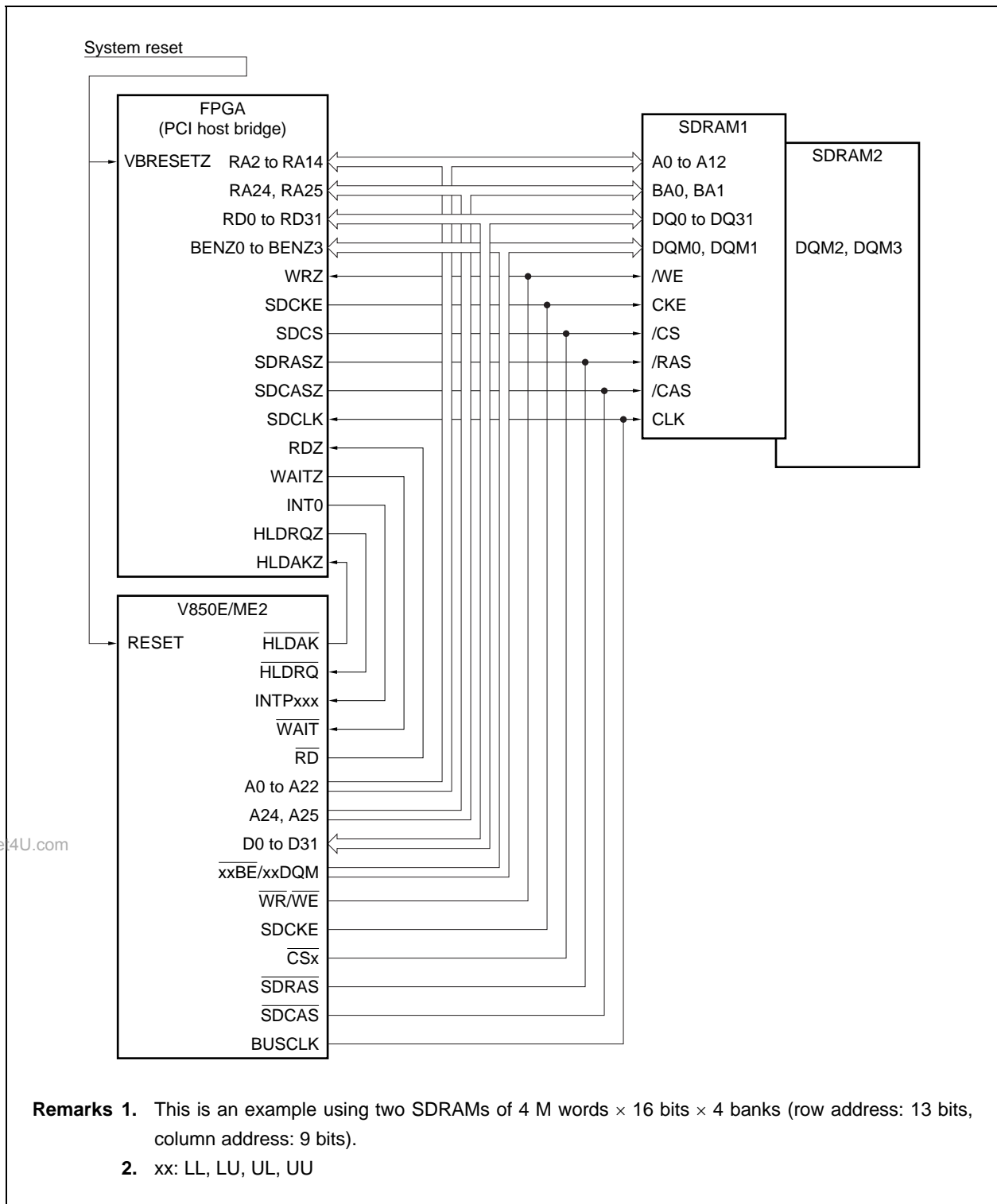

Remarks 1. This is an example using two SDRAMs of 4 M words × 16 bits × 4 banks (row address: 13 bits, column address: 9 bits).

2. xx: LL, LU, UL, UU

4.5.4 External connection diagram of PCI bus interface

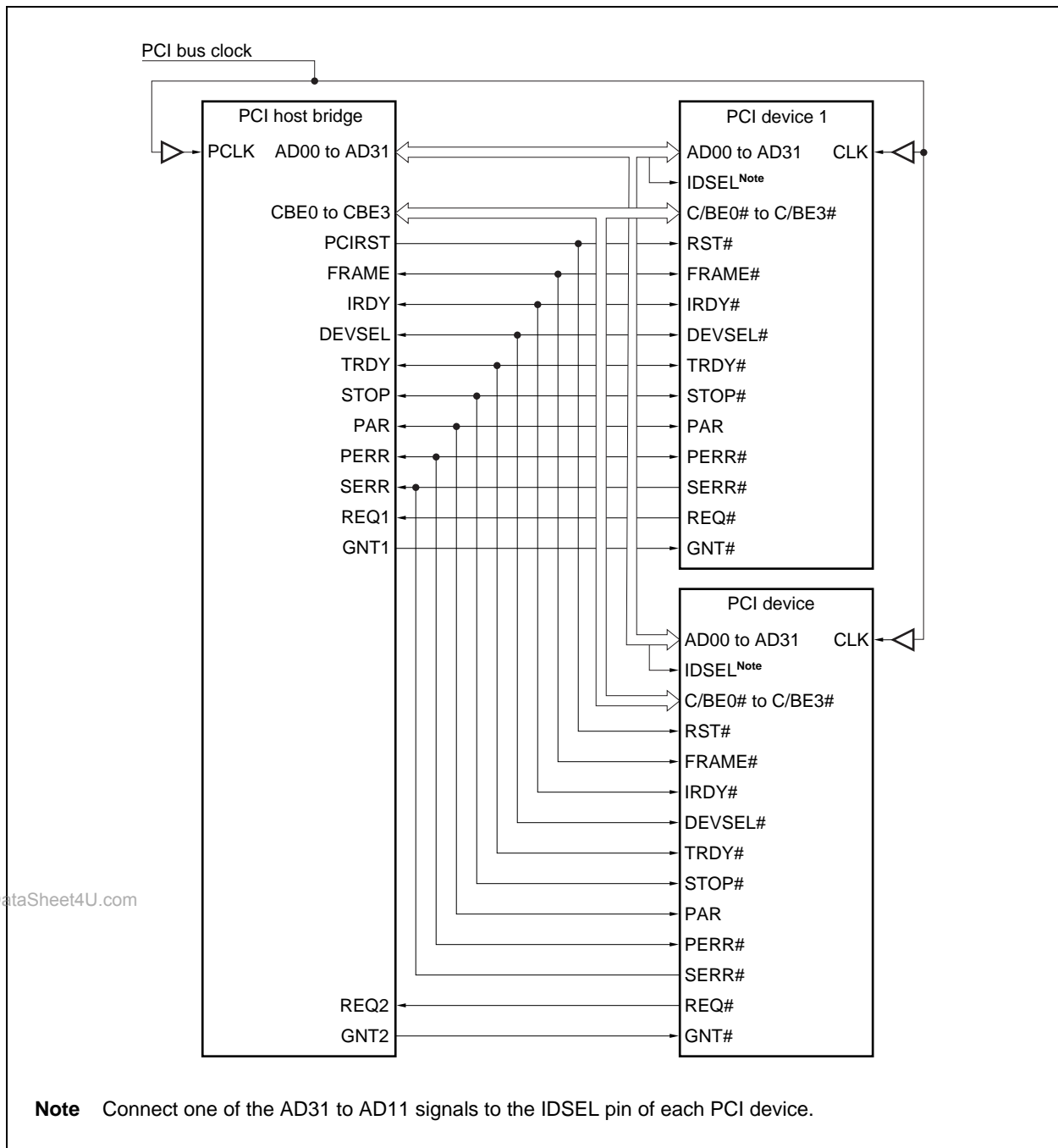

www.DataSheet4U.com

4.6 Cautions on Designing FPGA

Cautions when fitting an FPGA using Altera's "QuartusII Design Software" are shown below.

4.6.1 FPGA fitting design

- (1) Set the "I/O Standard" buffer type to "3.3-V PCI" for the following PCI bus interface pins.

Pin Name/Usage	Dir	I/O Standard
INTA	input	3.3-V PCI
INTB	input	3.3-V PCI
FRAME	bidir	3.3-V PCI
DEVSEL	bidir	3.3-V PCI
REQ1	input	3.3-V PCI
REQ2	input	3.3-V PCI
GNT1	output	3.3-V PCI
GNT2	output	3.3-V PCI
IRDY	bidir	3.3-V PCI
TRDY	bidir	3.3-V PCI
STOP	bidir	3.3-V PCI
PCIRST	output	3.3-V PCI
AD0 to AD31	bidir	3.3-V PCI
CBE0 to CBE3	bidir	3.3-V PCI
PAR	bidir	3.3-V PCI
PERR	bidir	3.3-V PCI
SERR	input	3.3-V PCI

- (2) Determine the pin assignment taking equal length wiring into consideration for the PCI bus interface pins.

www.DataSheet4U.com

- (3) Specify the "PCLK" and "SDCLK" signals as Global CLK.

4.6.2 PCI bus interface timing parameters (as constraint of PCI CLK = 33 MHz)

Adjust the timing so that the following PCI specification values are satisfied.

- (1) Input setup time to CLK point to point

Pin	Setup	Hold
REQ1, REQ2	10 ns	0 ns
Other PCI pins	7 ns	0 ns

(2) CLK to signal valid delay signals

Pin	MIN.	MAX.
All PCI pins	2 ns	11 ns

The following specification values apply to the PCI bus timing (PCI CLK = 33 MHz).

Figure 4-1. Output Timing

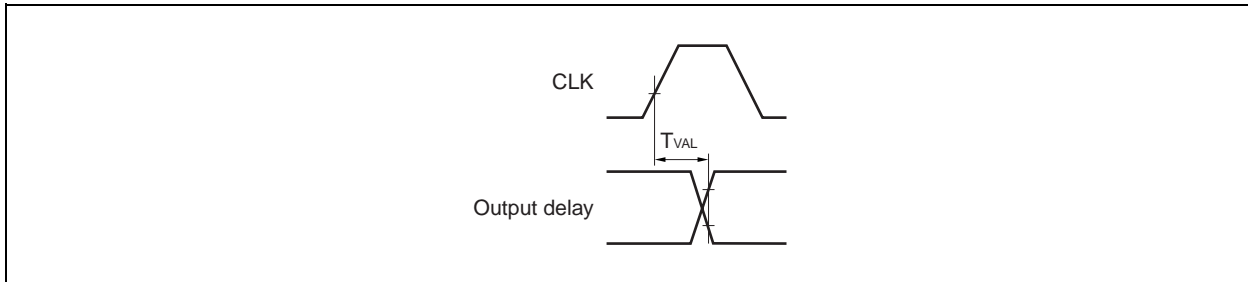

Figure 4-2. Input Timing

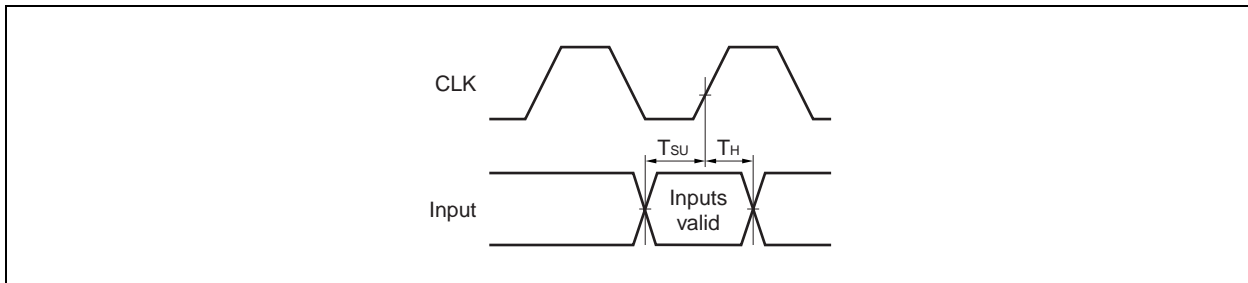

Table 4-1. 33 MHz Timing Parameters

Symbol	Parameter	MIN. (ns)	MAX. (ns)
T_{VAL}	CLK to signal valid delay based signals	2	11
$T_{VAL} (ptp)$	CLK to signal valid delay point to point signals	2	12
T_{SU}	Input setup time to CLK based signals	7	
$T_{SU} (ptp)$	Input setup time to CLK point to point signals	10	
T_H	Input hold time from CLK	0	

4.6.3 SDRAM interface timing

The timing for interfacing with SDRAM depends on the external bus interface and the SDRAM to be connected. Adjust the timing to suit the system.

CHAPTER 5 APPLICATION EXAMPLES

This chapter introduces the configuration of an evaluation board that mounts the V850E/ME2, as well as program examples.

This is an example of an application used to operate a HDD with an IDE controller mounted on the PCI connector.

5.1 Block Diagram of Evaluation Board

A block diagram of the evaluation board is shown below.

Figure 5-1. Block Diagram of Evaluation Board

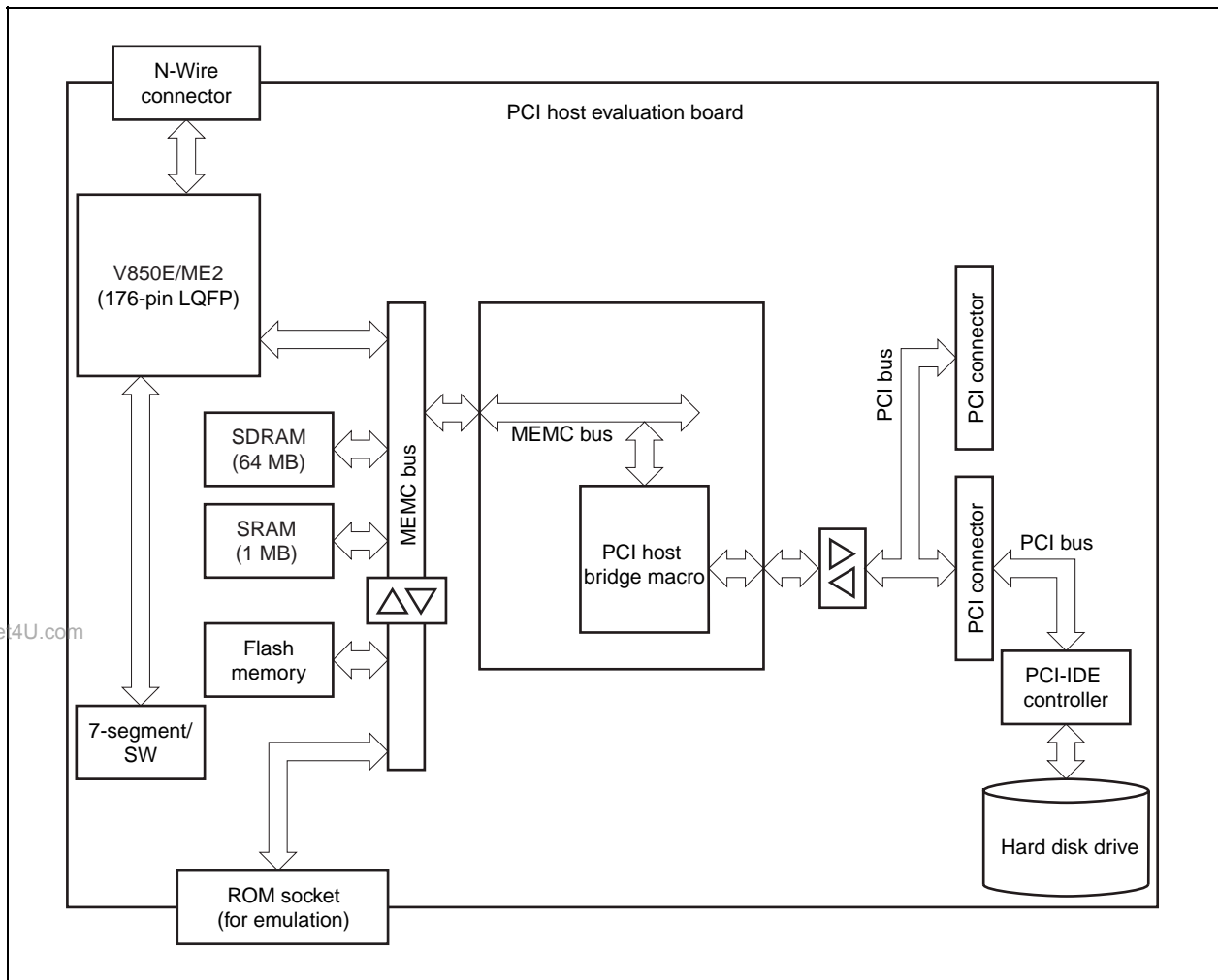

5.2 Specifications of Evaluation Board

The specifications of the evaluation board are as follows.

Table 5-1. Specifications of Evaluation Board

Item	Description
CPU	V850E/ME2
CPU operating frequency	30 MHz
MEMC bus operating frequency	30 MHz
Evaluation board memory	
Flash memory	CSZ0 area (32-bit width): 8 MB
SRAM	CSZ1 area (32-bit width): 1 MB
SDRAM	CSZ3 area (32-bit width): 64 MB
Evaluation board peripheral I/O	
PCI host bridge	CSZ6 area (32-bit width): PCI Rev.2.1 compliant host interface (33 MHz)
Other	
7-segment display	7-segment display × 2 can be controlled by V850E/ME2 general-purpose port

The device numbers of the PCI bus are assigned as follows.

Table 5-2. IDSEL Connection

Slot	Device Number	Remark
PCI Slot 1 (J2)	AD31	Connect AD31 to IDSEL
PCI Slot 2 (J3)	AD30	Connect AD30 to IDSEL

5.3 Example of Evaluation Board Connection Circuit

A circuit example of connection of the V850E/ME2 with SDRAM, FPGA, and a PCI device (slot) is shown below.

Figure 5-2. Example of Evaluation Board Connection Circuit

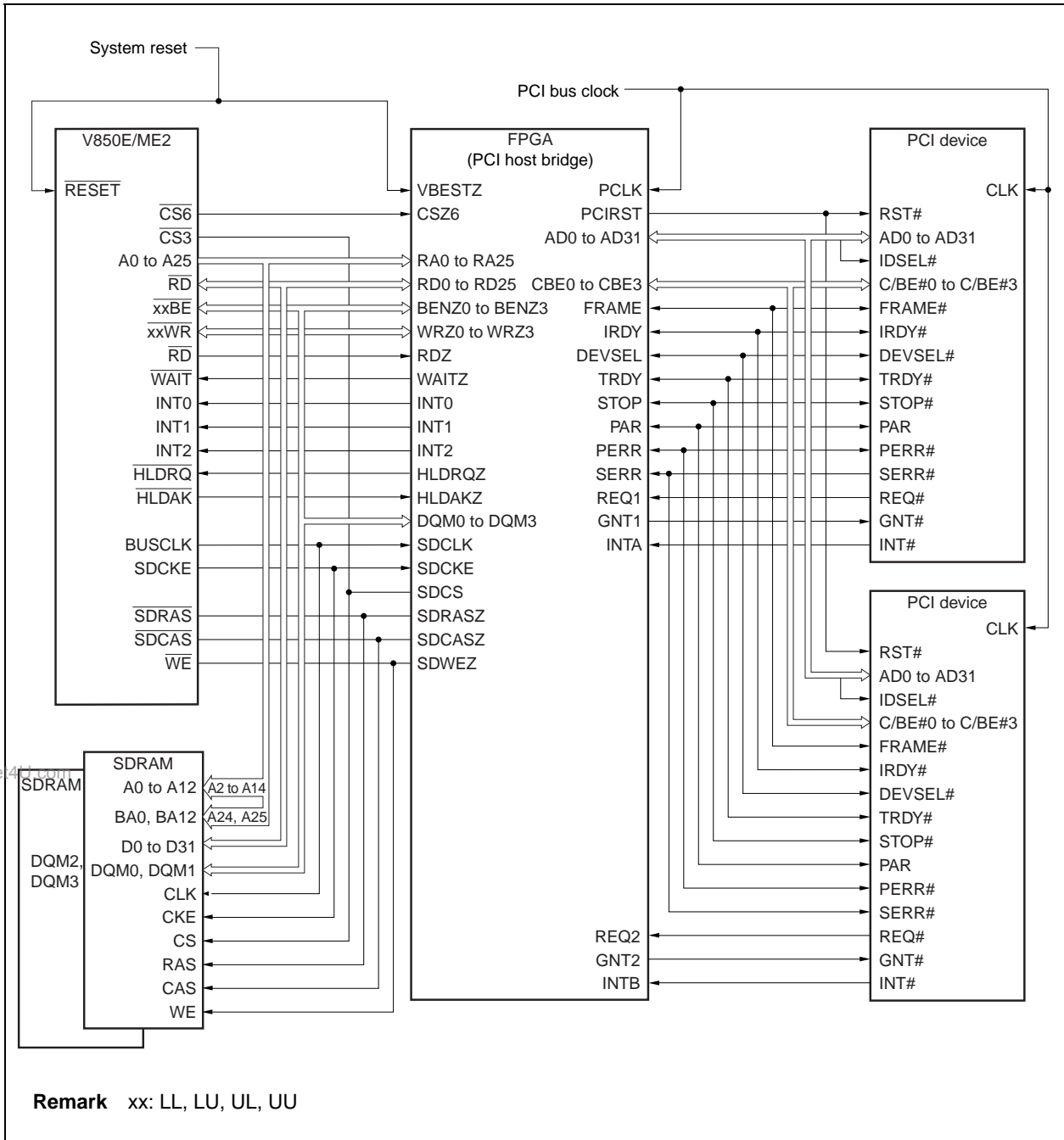

5.4 Evaluation Board Memory Space

The evaluation board memory space is shown below.

Figure 5-3. Evaluation Board Memory Space

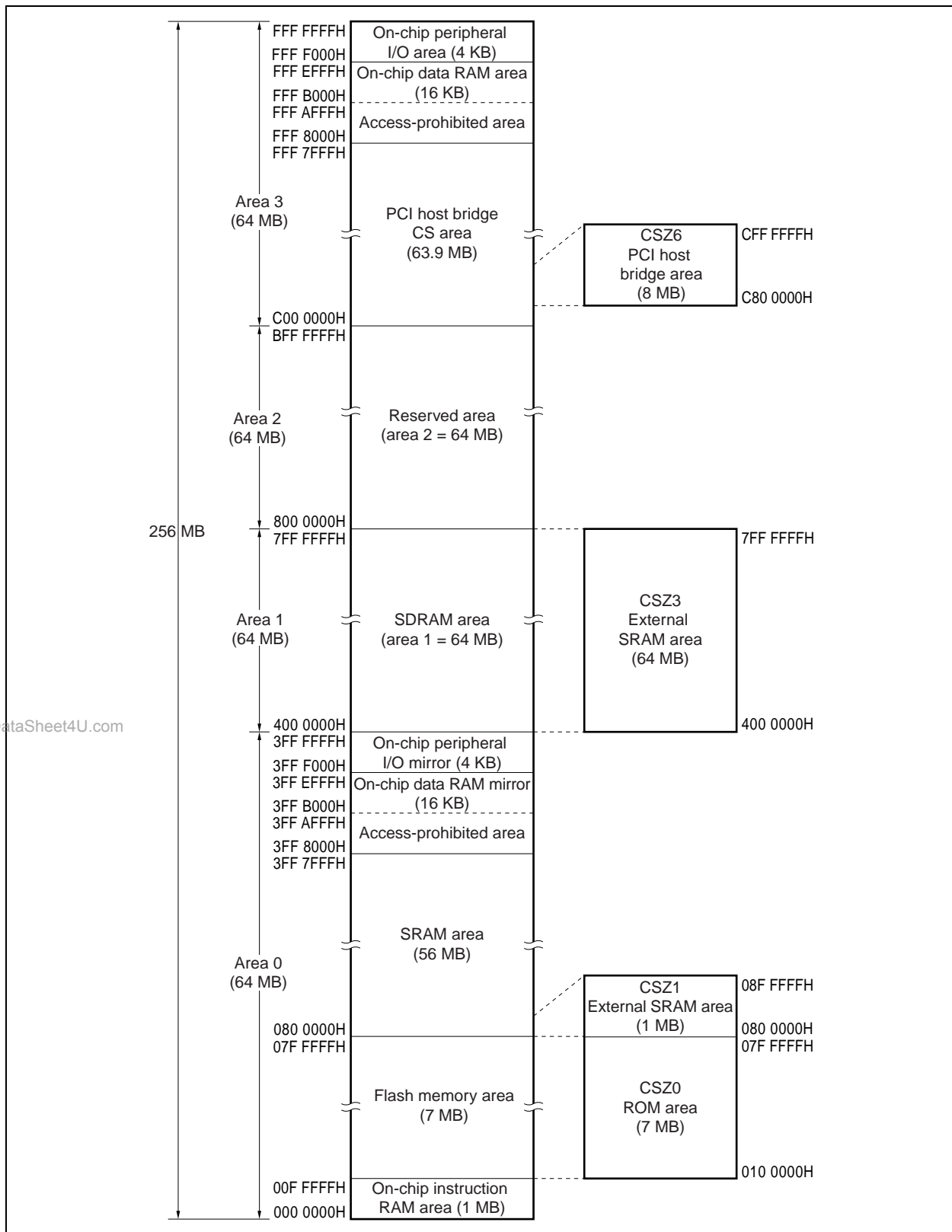

www.DataSheet4U.com

The PCI memory I/O space is assigned to the CSZ6 area.
 The base address of the PCI memory space is set to CC0 0000H.
 The base address of the PCI I/O space is set to C80 0000H.

Figure 5-4. Comparison Between CPU Memory Space and PCI Memory Space

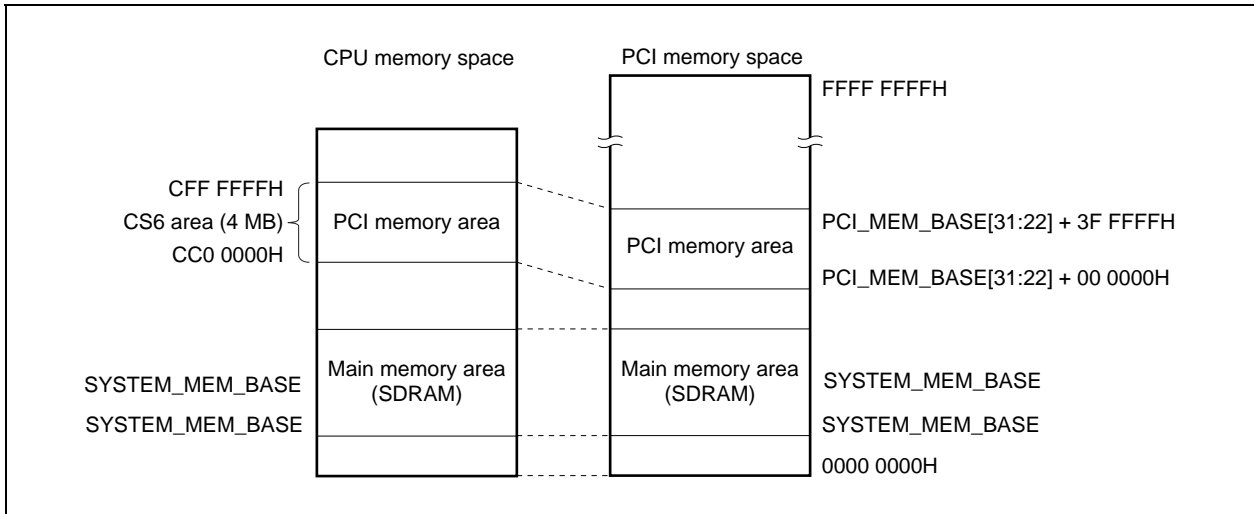
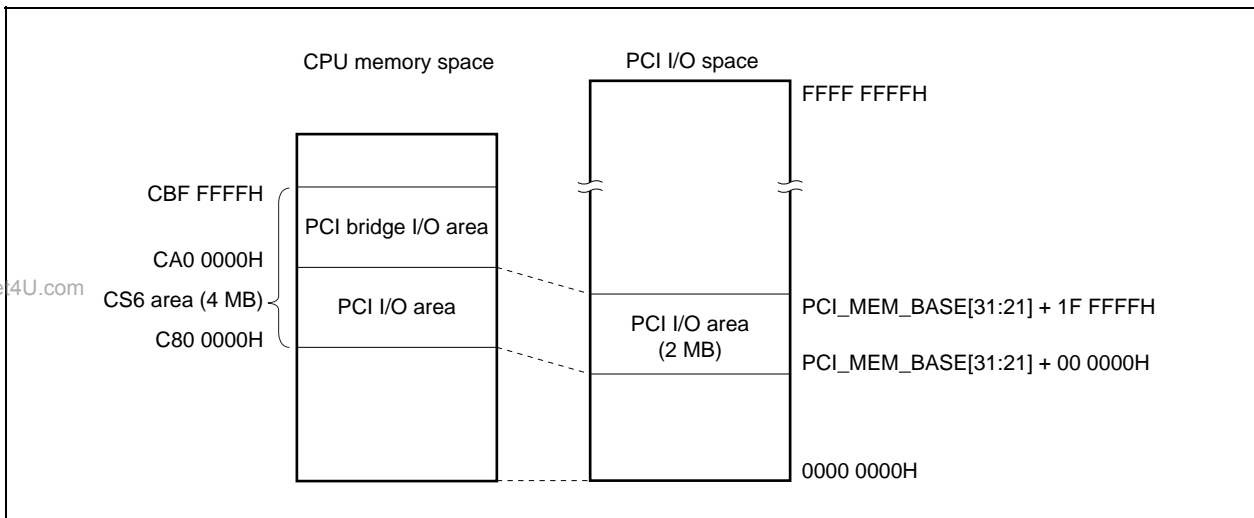

Figure 5-5. Comparison Between CPU Memory Space and PCI I/O Space



5.5 Sample Program Examples

This sample program is assumed to be used in an environment with the PCI-IDE board connected to the V850E/ME2 evaluation board as the PCI device.

The PCI-IDE board is connected to the IDE HDD, and the sample program accesses the IDE HDD.

5.5.1 Development tools

(1) **MULTI™ 1.8.9**

Integrated development environment made by Green Hills Software™, Inc.

(2) **PCI-IDE board**

IDE card of PCI interface connected to evaluation board.

Used by connecting IDE HDD in this application.

5.5.2 Program configuration

The sample program configuration is shown below.

(1) **PCI host bridge macro initialization sample program list**

First the PCI host bridge macro must be initialized for the CPU to access the PCI area.

The correspondence between the PCI memory space and CPU memory space, the interrupts from PCI, and access control from the CPU to the PCI memory space are set by the PCI host bridge macro registers.

(2) **PCI configuration space access sample program list**

When initialization of the PCI host bridge macro ends, initialization of each PCI device connected to the PCI bus is performed. Initialization is performed mainly by setting the configuration space registers existing in each PCI device. The configuration space registers can be accessed only by executing a configuration cycle using the PCI_CONFIG_ADD and PCI_CONFIG_DATA registers described in the register descriptions.

(3) **IDE HDD access sample program list**

When initialization of the PCI host bridge macro and PCI devices ends, the PCI device can actually be operated. The PCI device is operated by setting the registers assigned to the configuration space and PCI I/O area.

The IDE bus setting is performed and the IDE HDD is actually accessed by operating the PCI-IDE board registers in this sample code.

5.5.3 V850E/ME2 PCI host bridge macro initialization sample program list

```

////////////////////////////////////
// V850E/ME2 - PCI Host Bridge Macro initialization sample //
// Overview: Initializes PCI Host Bridge Macro by setting //
//           PCI Bridge IO area register group.           //
//           Specific initialization is described in       //
//           function PCI_HBM_Init().                     //
//                                                       //
// PCI_HBM_Init() is called after functions required for //
// accessing Host Bridge Macro, such as CPU and peripheral //
// I/O, are initialized.                                 //
//                                                       //
////////////////////////////////////

////////////////////////////////////
// Defines base address of PCI area and SDRAM area.      //
// Start address of PCI area is 0C80_0000H, and start address //
// of SDRAM area is 0400_0000H in this application.       //
////////////////////////////////////
#define BASE_ADDRESS_ME2PCIIF          (0x0C800000)

#define BASE_ADDRESS_PCI_IO            (BASE_ADDRESS_ME2PCIIF)
#define BASE_ADDRESS_PCI_BRIDGE_IO    (BASE_ADDRESS_ME2PCIIF + 0x00200000)
#define BASE_ADDRESS_PCI_MEM          (BASE_ADDRESS_ME2PCIIF + 0x00400000)

#define BASE_ADDRESS_SDRAM             (0x04000000)
#define RANGE_SDRAM                    (0x03FFFFFF) // 64MB

////////////////////////////////////
// PCI Host Bridge Macro register address definition //
////////////////////////////////////
#define PHBMR_PCI_CONFIG_DATA         (BASE_ADDRESS_PCI_BRIDGE_IO+0x00)
#define PHBMR_PCI_CONFIG_ADD          (BASE_ADDRESS_PCI_BRIDGE_IO+0x04)
#define PHBMR_PCI_CONTROL              (BASE_ADDRESS_PCI_BRIDGE_IO+0x08)
#define PHBMR_PCI_IO_BASE              (BASE_ADDRESS_PCI_BRIDGE_IO+0x10)
#define PHBMR_PCI_MEM_BASE             (BASE_ADDRESS_PCI_BRIDGE_IO+0x14)
#define PHBMR_PCI_INT_CTL              (BASE_ADDRESS_PCI_BRIDGE_IO+0x18)
#define PHBMR_PCI_ERR_ADD              (BASE_ADDRESS_PCI_BRIDGE_IO+0x1C)
#define PHBMR_SYSTEM_MEM_BASE          (BASE_ADDRESS_PCI_BRIDGE_IO+0x40)
#define PHBMR_SYSTEM_MEM_RANGE         (BASE_ADDRESS_PCI_BRIDGE_IO+0x44)
#define PHBMR_SDRAM_CTL                (BASE_ADDRESS_PCI_BRIDGE_IO+0x48)

////////////////////////////////////
// Macro definition for register access //
////////////////////////////////////
#define V850EME2_REGW(x)               *((volatile unsigned int *) ((int)x))

```

```

////////////////////////////////////
// Function name: PCI_HBM_Init //
// Function: Initializes PCI Host Bridge Macro. //
// Argument: None //
// Return value: None //
// Remark: Base addresses of this initialization sample are as follows.//
// - Base address of PCI I/O space: 0C80_0000H //
// - Base address of PCI memory space: 0CC0_0000H //
// - Base address on PCI bus memory space in which //
// main memory (SDRAM) is mapped: 0400_0000H //
// - Range of PCI bus memory space in which //
// main memory (SDRAM) is mapped: 03FF_FFFFH //
// Other settings are required according to system //
// requirements and mounting. //
////////////////////////////////////
void PCI_HBM_Init(void)
{

    V850EME2_REGW(PHBMR_PCI_CONTROL) = 0x07000110;
    // PCI_CONTROL register
    // bit 31-24: PCI_PARKCNT = 1
    // (Set time for shifting to bus parking to 7)
    // bit 15-08: PCI_REQ = 1 (Enable I_REQ_B0)
    // bit 4: PCI_RESET bit = 1 (Release PCI bus reset)

    V850EME2_REGW(PHBMR_PCI_IO_BASE) = BASE_ADDRESS_PCI_IO;
    // PCI_IO_BASE register
    // Set PCI I/O space base address to C800000H.

    V850EME2_REGW(PHBMR_PCI_MEM_BASE) = BASE_ADDRESS_PCI_MEM;
    // PCI_MEM_BASE register
    // Set PCI memory space base address to CC00000H.

    V850EME2_REGW(PHBMR_PCI_CONTROL) = 0x07000113;
    // PCI_CONTROL register
    // bit 31-24: PCI_PARKCNT = 1
    // (Set time for shifting to bus parking to 7)
    // bit 15-08: PCI_REQ = 1 (Enable I_REQ_B0)
    // bit 4: PCI_RESET bit = 1 (Release PCI bus reset)
    // bit 1: PCI_MEM_EN bit = 1
    // (Enable access from CPU to PCI memory area)
    // bit 0: PCI_IO_EN bit = 1
    // (Enable access from CPU to PCI I/O area)

    V850EME2_REGW(PHBMR_SYSTEM_MEM_BASE) = BASE_ADDRESS_SDRAM;
    // SYSTEM_MEM_BASE register
    // Set base address on PCI bus memory space in which main
    // memory (SDRAM) is mapped to 4000000H.

```

```

V850EME2_REGW(PHBMR_SYSTEM_MEM_RANGE) = RANGE_SDRAM;
// SYSTEM_MEM_RANGE register
// Set range of PCI bus memory space in which main
// memory (SDRAM) is mapped to 3FFFFFFH (64 MB).

V850EME2_REGW(PHBMR_SDRAM_CTL) = 0x00071211;
// SDRAM_CTL register
// bit 23-16: CYCLE_LATENCY = 07H
//             (Set latency for successive main memory
//             (SDRAM) access from PCI device to 210 ns)
// bit 12: BUS_SIZE = 1B
//           (Set bit width of data bus to 32 bits)
// bit 09-08: CAS_LATENCY = 10B (Set CAS latency to 2)
// bit 05-04: WAIT_STATE = 01B
//           (Set wait interval of ACT → CMD, PRE → ACT,
//           and CMD → ACT to 1 clock)
// bit 01-00: COLUMN_SIZE = 01B
//           (Set bit width of column address to 9 bits)

V850EME2_REGW(PHBMR_PCI_CONTROL) = 0x07000717;
// bit 31-24: PCI_PARKCNT = 1
//           (Set time for shifting to bus parking to 7)
// bit 15-08: PCI_REQ = 1 (Enable I_REQ_B0)
// bit 4: PCI_RESET bit = 1 (Release PCI bus reset)
// bit 1: PCI_MEM_EN bit = 1
//           (Enable access from CPU to PCI memory area)
// bit 0: PCI_IO_EN bit = 1
//           (Enable access from CPU to PCI I/O area)

```

www.DataSheet4U.com
return;

}

```

//////////////////////////////////////////////////////////////////
// Function name: main //
// Function: Initializes PCI Host Bridge Macro. //
// Argument: None //
// Return value: 0: Normal end //
//////////////////////////////////////////////////////////////////

```

```
int main(void)
```

```
{
```

```
    // Initializes PCI Host Bridge Macro.
```

```
    PCI_HBM_Init();
```

```
    return 0;
```

```
}
```

5.5.4 PCI configuration space access sample program list

```

////////////////////////////////////
// PCI configuration space access sample //
// Overview: Configuration space is accessed using procedure //
// shown below. //
// 1) Write 32-bit value indicating PCI device, function //
// number, and register number to be accessed to //
// PCI_CONFIG_ADD register of PCI Host Bridge Macro. //
// 2) When reading configuration space register, read //
// (word access) 32-bit value in PCI_CONFIG_DATA //
// register of PCI Host Bridge Macro. //
// When writing to configuration space register, write //
// (word access) 32-bit value to PCI_CONFIG_DATA register //
// of PCI Host Bridge Macro. //
// //
// This procedure is combined in functions PCI_ConfigRead //
// and PCI_ConfigWrite shown below. //
// Function PCI_Config_BaseAddressInit uses function //
// PCI_ConfigWrite to set base address register in //
// configuration space. //
// //
////////////////////////////////////

```

```

////////////////////////////////////
// Type declaration //
////////////////////////////////////
typedef char          BYTE;
typedef short int    HWORD;
typedef int          WORD;
typedef unsigned char UBYTE;
typedef unsigned short int UHWORD;
typedef unsigned int UWORD;
typedef volatile unsigned char VUBYTE;
typedef volatile unsigned short int VUHWORD;
typedef volatile unsigned int VUWORD;

```

```

////////////////////////////////////
// Function name: PCI_ConfigRead //
// Function: Reads 32-bit value in PCI configuration space. //
// Argument: ConfigAdd: Register address of configuration space//
// Return value: Read configuration space register data //
////////////////////////////////////
UWORD PCI_ConfigRead(UWORD ConfigAdd)
{
    V850EME2_REGW(PHBMR_PCI_CONFIG_ADD) = ConfigAdd;
    return V850EME2_REGW(PHBMR_PCI_CONFIG_DATA);
}

```

```

////////////////////////////////////
// Function name: PCI_ConfigWrite //
// Function: Writes 32-bit value to PCI configuration space. //
// Argument: ConfigAdd: Register address of configuration space//
//           ConfigData: Register data of configuration space //
// Return value: None //
////////////////////////////////////
void PCI_ConfigWrite(UWORD ConfigAdd, UWORD ConfigData)
{
    V850EME2_REGW(PHBMR_PCI_CONFIG_ADD) = ConfigAdd;
    V850EME2_REGW(PHBMR_PCI_CONFIG_DATA) = ConfigData;

    return;
}

////////////////////////////////////
// Function name: PCI_Config_BaseAddressInit //
// Function: Sets base address of configuration space. //
// Argument: None //
// Return value: None //
// Details: Sets base address register of offset 10H to 24H in //
//           configuration space of PCI device connected to AD30 //
//           signal by IDSEL as follows. //
// //
// ATA Command Register Base Address (10H) : 0C80_0000H //
// ATA Control Register Base Address (14H) : 0C80_0008H //
// Bus Master Control Register Base Address(18H) : 0C80_0010H //
// //
////////////////////////////////////
void PCI_Config_BaseAddressInit(void)
{
    UWORD ConfigAddress;
    UWORD ConfigData;

    //////////////////////////////////
    // ATA Command Register Base Address //
    //////////////////////////////////
    ConfigAddress = 0x40000010;
    // bit 31-11 : IDSEL specification = 01000000000000000000b
    //           Select PCI device connected to AD30
    // bit 10-08 : Function number = 00b
    // bit 07-02 : Register number = 4 (000100b),
    //           -> ATA Command Register Base Address
    //           (In the case of PCI-IDE ASIC board used in this application)
    // bit 01-00 : 00b (fixed)

    PCI_ConfigWrite(ConfigAddress, 0x0C800000);
}

```

```

////////////////////////////////////
// ATA Control Register Base Address //
////////////////////////////////////
ConfigAddress = 0x40000014;
// bit 31-11 : IDSEL specification = 01000000000000000000b
//           Select PCI device connected to AD30
// bit 10-08 : Function number = 00b
// bit 07-02 : Register number = 5 (000101b),
//           -> ATA Control Register Base Address
//           (In the case of PCI-IDE ASIC board used in this application)
// bit 01-00 : 00b (fixed)

```

```
PCI_ConfigWrite(ConfigAddress, 0x0C800008);
```

```

////////////////////////////////////
// Bus Master Control Register Base Address //
////////////////////////////////////
ConfigAddress = 0x40000018;
// bit 31-11 : IDSEL specification = 01000000000000000000b
//           Select PCI device connected to AD30
// bit 10-08 : Function number = 00b
// bit 07-02 : Register number = 6 (000110b)
//           -> Bus Master Control Register Base Address
//           (In the case of PCI-IDE ASIC board used in this application)
// bit 01-00 : 00b (fixed)

```

```
PCI_ConfigWrite(ConfigAddress, 0x0C800010);
```

```
return;
```

```
www.DataSheet4U.com
```

```

////////////////////////////////////
// Function name: main //
// Function: Sets base address of configuration space. //
// Argument: None //
// Return value: 0: Normal end //
////////////////////////////////////
int main(void)
{
    // Initializes PCI Host Bridge Macro.
    PCI_HBM_Init();

    // Sets base address of configuration space.
    PCI_Config_BaseAddressInit();

    return 0;
}

```

5.5.5 IDE HDD access sample program list

```

////////////////////////////////////
// IDE HDD access sample //
// Overview: Issues ATA commands to HDD, which is ATA device, via PCI-IDE //
// ASIC board connected to PCI slot of evaluation board. //
// ATA commands to be issued are as follows. //
// //
// IDLE IMMEDIATE, IDENTIFY DEVICE, SET FEATURE, //
// READ SECTOR(S), WRITE SECTOR(S), READ DMA, WRITE DMA //
// //
// ATA command is executed by executing device selection //
// protocol to determine that command is issued to either //
// Master Device or Slave Device. ATA command is issued //
// and data is transferred using transfer protocol //
// corresponding to each ATA command. Four transfer //
// protocols, PIO datain transfer, PIO dataout transfer, //
// PIO nondata transfer, and DMA transfer, are available. //
// //
// This sample program is provided with device selection //
// protocol and four transfer protocols as functions. //
// Corresponding transfer protocol function is called //
// from function processing each ATA command. //
// //
////////////////////////////////////

```

```

////////////////////////////////////
// PCI-IDE ASIC board register address definition //
////////////////////////////////////

```

www.DataSheet4U.com

```

////////////////////////////////////
// IDE Command Area //
////////////////////////////////////
#define IDEREG_DATA ((VUWORD*) (BASE_ADDRESS_PCI_IO + 0x00))
#define IDEREG_ERROR ((VUBYTE*) (BASE_ADDRESS_PCI_IO + 0x01))
#define IDEREG_ERROR_ERR_BIT (0x01)
#define IDEREG_FEATURES ((VUBYTE*) (BASE_ADDRESS_PCI_IO + 0x01))
#define IDEREG_SECTOR_COUNT ((VUBYTE*) (BASE_ADDRESS_PCI_IO + 0x02))
#define IDEREG_SECTOR_NUMBER ((VUBYTE*) (BASE_ADDRESS_PCI_IO + 0x03))
#define IDEREG_CYLINDER_LOW ((VUBYTE*) (BASE_ADDRESS_PCI_IO + 0x04))
#define IDEREG_CYLINDER_HIGH ((VUBYTE*) (BASE_ADDRESS_PCI_IO + 0x05))
#define IDEREG_DEVICE_HEAD ((VUBYTE*) (BASE_ADDRESS_PCI_IO + 0x06))
#define IDEREG_STATUS ((VUBYTE*) (BASE_ADDRESS_PCI_IO + 0x07))
#define IDEREG_COMMAND ((VUBYTE*) (BASE_ADDRESS_PCI_IO + 0x07))

////////////////////////////////////
// IDE Control Area //
////////////////////////////////////

```

```

#define IDEREG_ALTERNATE_STATUS                ((VUBYTE*) (BASE_ADDRESS_PCI_IO + 0x0E))
#define IDEREG_DEVICE_CONTROL                 ((VUBYTE*) (BASE_ADDRESS_PCI_IO + 0x0E))

//////////
// Bus Master I/O Area //
//////////
#define IDEREG_BUSMASTER_START_STOP          ((VUWORD*) (BASE_ADDRESS_PCI_IO + 0x10))
#define IDEREG_DSCTBL_START_ADDRESS          ((VUWORD*) (BASE_ADDRESS_PCI_IO + 0x14))
#define IDEREG_INTERRUPT_CONTROL              ((VUWORD*) (BASE_ADDRESS_PCI_IO + 0x18))

//////////
// Error code definition //
//////////
#define STATUS_SUCCESS                        0
#define STATUS_TIMEOUT_BSY0_DRQ0             1
#define STATUS_TIMEOUT_DEVICE_SELECTION      1
#define STATUS_TIMEOUT_DRDY1                 2
#define STATUS_TIMEOUT_BSY0                  3
#define STATUS_TIMEOUT_INTRQ                 4
#define STATUS_TIMEOUT_BMEND                  5
#define STATUS_IDE_ERROR(IDE_ERROR_REG)      (0x10000000 | (UWORD) (IDE_ERROR_REG))

//////////
// Transfer mode timing setting value definition //
//////////

// See IDE specifications for details of transfer mode timing setting values shown below.

// Setting value passed to SET_FEATURES command in Set_Transfer_mode()
#define PIO_MODE0          0x08
#define UDMA_MODE0         0x40

// Setting value of timing register (when IDE operation clock is 33 MHz)
#define IDE_PIO_TIMING_IDE33MHz_MODE0      (0x00020906)
#define IDE_UDMA_TIMING1_IDE33MHz_MODE0    (0x00000202)
#define IDE_UDMA_TIMING2_IDE33MHz_MODE0    (0x00000005)

//////////
// Structure declaration //
//////////

//////////
// Structure for issuing ATA command //
//////////
typedef struct{
    UBYTE features;           // Features register
    UBYTE sector_count;      // Sector Count register
    UBYTE sector_number;     // Sector Number register

```



```

    UBYTE cylinder_low;          // Cylinder Low register
    UBYTE cylinder_high;        // Cylinder High register
    UBYTE device_head;          // Device/Head register
    UBYTE command;              // Command register
} ATA_COMMAND;

////////////////////////////////////
// Descriptor table for UltraDMA transfer //
////////////////////////////////////
typedef struct{
    UWORD transfer_address;      // Transfer address
    UWORD transfer_byte;        // Number of transfer bytes
    UWORD next_table_address;    // Next table address
} DESCRIPTOR_TABLE;

////////////////////////////////////
// Initialization function //
////////////////////////////////////

////////////////////////////////////
// Function name: PCI_Config_ModeInit          //
// Function: Sets initialization of PCI-IDE ASIC board. //
// Argument: None                               //
// Return value: None                            //
// Details: Sets handling of interrupts and errors, coding and //
//           then resets IDE bus.                //
//                                               //
////////////////////////////////////
void PCI_Config_ModeInit(void)
{
    UWORD ConfigAddress;
    UWORD ConfigData;

    ///////////////////////////////////
    // Setting of PCI functions //
    ///////////////////////////////////
    ConfigAddress = 0x40000004;
    // bit 31-11 : IDSEL specification = 01000000000000000000b
    //           Select PCI device connected to AD30
    // bit 10-08 : Function number = 00b
    // bit 07-02 : Register number = 1 (000001b)
    //           -> Status / Command
    // bit 01-00 : 00b (fixed)

    ConfigData = 0x02000145;
    // bit 26-25 : DEVSEL timing = 01b (medium fixed)
    // bit      8 : SERR Enable = 1b : Output pci_serr.
    // bit      6 : Parity Error Response = 1b : Output pci_serr

```

```

//          when Parity Error is detected.
// bit      2 : Bus Master = 1b : Enable PCI Bus Master transfer
// bit      0 : IO Space = 1b : Enable IO access to PCI-IDE ASIC board

PCI_ConfigWrite(ConfigAddress, ConfigData);

////////////////////////////////////
// Setting DES to disable //
////////////////////////////////////
ConfigAddress = 0x40000058;
// bit 31-11 : IDSEL specification = 01000000000000000000b
//          Select PCI device connected to AD30
// bit 10-08 : Function number = 00b
// bit 07-02 : Register number = 22 (010110b),
//          -> IDE Bus Master Control
//          (In the case of PCI-IDE ASIC board used in this application)
// bit 01-00 : 00b (fixed)

// IDE Bus Master Control
// Disable DES (Set bit16 des_on to 0)
ConfigData = PCI_ConfigRead(ConfigAddress);
PCI_ConfigWrite(ConfigAddress, ConfigData & 0xFFFFEFFF);

////////////////////////////////////
// Setting of Interrupt Control register //
////////////////////////////////////
*IDEREG_INTERRUPT_CONTROL &= 0xFFFCFFFF;
// bit      17 : PCI Bus Master End Interrupt Mask = 0b (Interrupt enabled)
// bit      16 : PCI I/F Interrupt Mask = 0b (Interrupt enabled)

www.DataSheet4U.com
////////////////////////////////////
// Setting of Device Command register //
////////////////////////////////////
*IDEREG_DEVICE_CONTROL = 0x00;
// bit      2 : nIEN = 0b (Set INTRQ signal to enable)

////////////////////////////////////
// IDE Bus reset //
////////////////////////////////////
ConfigAddress = 0x40000044;
// bit 31-11 : IDSEL specification = 01000000000000000000b
//          Select PCI device connected to AD30
// bit 10-08 : Function number = 00b
// bit 07-02 : Register number = 17 (010001b),
//          -> IDE Reset Register
//          (In the case of PCI-IDE ASIC board used in this application)
// bit 01-00 : 00b (fixed)

```

```

ConfigData = 0x00000001;
// bit      0 : IDE I/F RESET Port   = 1b :
//          Output IDE RESETX signal output to IDE I/F.

PCI_ConfigWrite(ConfigAddress, ConfigData);

return;
}

////////////////////////////////////
// Transfer mode setting function //
////////////////////////////////////

////////////////////////////////////
// Function name: Set_Transfer_Mode           //
// Function: Setting of transfer mode         //
// Argument: dev_num : Device selection (0:Master/1:Slave) //
//          mode : Transfer mode              //
// Return value:                               //
//   STATUS_SUCCESS : Normal end               //
//   STATUS_TIMEOUT_DEVICE_SELECTION : DEVICE SELECTION error end //
//   STATUS_TIMEOUT_DRDY1 : DRDY=1 timeout error end //
//   STATUS_TIMEOUT_INTRQ : INTRQ timeout error end //
//   STATUS_IDE_ERROR : Error end after command execution //
//                                               //
////////////////////////////////////
int Set_Transfer_Mode(int dev_num, UBYTE mode)
{
    status = ATA_Set_Features(dev_num, 0x03, mode);
    return status;
}

////////////////////////////////////
// Function name: Set_PIO_Timing              //
// Function: Setting of PIO Timing register   //
// Argument: pio_timing : Value set to PIO Timing register //
// Return value: None                          //
//                                               //
////////////////////////////////////
void Set_PIO_Timing(UWORD pio_timing)
{
    UWORD ConfigAddress;
    UWORD ConfigData;

    ConfigAddress = 0x40000048;
    // bit 31-11 : IDSEL specification = 01000000000000000000b
    //          Select PCI device connected to AD30
    // bit 10-08 : Function number = 00b

```

```
// bit 07-02 : Register number = 18 (010010b)
//          -> PIO Timing (In the case of PCI-IDE ASIC board used in this application)
// bit 01-00 : 00b (fixed)
```

```
PCI_ConfigWrite( ConfigAddress, pio_timing );
```

```
return;
```

```
}
```

```
/////////////////////////////////////////////////////////////////
// Function name: Set_UDMA_Timing //
// Function: Setting of UltraDMA Timing1, 2 registers //
// Argument: udma_timing1 : Value set to UltraDMA Timing1 register //
//          udma_timing2 : Value set to UltraDMA Timing2 register //
// Return value: None //
// //
/////////////////////////////////////////////////////////////////
```

```
void Set_UDMA_Timing(UWORD udma_timing1, UWORD udma_timing2)
```

```
{
```

```
UWORD ConfigAddress;
```

```
UWORD ConfigData;
```

```
ConfigAddress = 0x4000004C;
```

```
// bit 31-11 : IDSEL specification = 01000000000000000000b
```

```
//          Select PCI device connected to AD30
```

```
// bit 10-08 : Function number = 00b
```

```
// bit 07-02 : Register number = 19 (010011b)
```

```
//          -> UltraDMA Timing1
```

```
//          (In the case of PCI-IDE ASIC board used in this application)
```

```
// bit 01-00 : 00b (fixed)
```

www.DataSheet4U.com

```
PCI_ConfigWrite( ConfigAddress, udma_timing1 );
```

```
ConfigAddress = 0x40000050;
```

```
// bit 31-11 : IDSEL specification = 01000000000000000000b
```

```
//          Select PCI device connected to AD30
```

```
// bit 10-08 : Function number = 00b
```

```
// bit 07-02 : Register number = 20 (010100b)
```

```
//          -> UltraDMA Timing2
```

```
//          (In the case of PCI-IDE ASIC board used in this application)
```

```
// bit 01-00 : 00b (fixed)
```

```
PCI_ConfigWrite( ConfigAddress, udma_timing2 );
```

```
return;
```

```
}
```

```
/////////////////////////////////////////////////////////////////
```

```

// ATA command execution function //
////////////////////////////////////

////////////////////////////////////
// Function name: ATA_Set_Features //
// Function: Executes SET FEATURES command (Protocol:ND, Command:EFh). //
// Argument: dev_num : Device selection (0:Master/1:Slave) //
// Return value: //
// STATUS_SUCCESS : Normal end //
// STATUS_TIMEOUT_DEVICE_SELECTION : DEVICE SELECTION error end //
// STATUS_TIMEOUT_DRDY1 : DRDY=1 timeout error end //
// STATUS_TIMEOUT_INTRQ : INTRQ timeout error end //
// STATUS_IDE_ERROR : Error end after command execution //
// //
////////////////////////////////////
int ATA_Set_Features(int dev_num, int sub_cmd, int mode)
{
    int status;
    ATA_COMMAND ac;

    ac.features      = sub_cmd;          // Features register
    ac.sector_count  = mode;             // SectorCount register
    ac.sector_number = 0x00;             // SectorNumber register
    ac.cylinder_low  = 0x00;             // CylinderLow register
    ac.cylinder_high = 0x00;             // CylinderHigh register
    ac.device_head   = dev_num<<4;      // Device/Head register
    ac.command       = 0xEF;             // Command register

    status = ATA_PIO_nondata(&ac);
    return status;
}

////////////////////////////////////
// Function name: ATA_Idle_Immediate //
// Function: Executes IDLE IMMEDIATE command (Protocol:ND, Command:Elh). //
// Argument: dev_num : Device selection (0:Master/1:Slave) //
// Return value: //
// STATUS_SUCCESS : Normal end //
// STATUS_TIMEOUT_DEVICE_SELECTION : DEVICE SELECTION error end //
// STATUS_TIMEOUT_DRDY1 : DRDY=1 timeout error end //
// STATUS_TIMEOUT_INTRQ : INTRQ timeout error end //
// STATUS_IDE_ERROR : Error end after command execution //
// //
////////////////////////////////////
int ATA_Idle_Immediate(int dev_num)
{
    ATA_COMMAND ac;

```

```

ac.features          = 0x00;          // Features register
ac.sector_count      = 0x00;          // SectorCount register
ac.sector_number     = 0x00;          // SectorNumber register
ac.cylinder_low      = 0x00;          // CylinderLow register
ac.cylinder_high     = 0x00;          // CylinderHigh register
ac.device_head       = dev_num<<4;    // Device/Head register
ac.command           = 0xE1;          // Command register

```

```
status = ATA_PIO_nondata(&ac);
```

```
return status;
```

```
}
```

```

/////////////////////////////////////////////////////////////////
// Function name: ATA_Identify_Device                               //
// Function: Executes IDENTIFY DEVICE command (Protocol:PI, Command:ECh).//
// Argument: dev_num : Device selection (0:Master/1:Slave)         //
//           buff : Buffer pointer                                  //
// Return value:                                                    //
//   STATUS_SUCCESS : Normal end                                    //
//   STATUS_TIMEOUT_DEVICE_SELECTION : DEVICE SELECTION error end //
//   STATUS_TIMEOUT_DRDY1 : DRDY=1 timeout error end               //
//   STATUS_TIMEOUT_INTRQ : INTRQ timeout error end                //
//   STATUS_IDE_ERROR : Error end after command execution           //
//                                                                 //
/////////////////////////////////////////////////////////////////

```

```
int ATA_Identify_Device(int dev_num, void *buff)
```

```
{
```

```
ATA_COMMAND ac;
```

```
int status;
```

www.DataSheet4U.com

```

ac.features          = 0x00;          // Features register
ac.sector_count      = 0x00;          // SectorCount register
ac.sector_number     = 0x00;          // SectorNumber register
ac.cylinder_low      = 0x00;          // CylinderLow register
ac.cylinder_high     = 0x00;          // CylinderHigh register

```

```
ac.dev_head          = dev_num << 4; // Device/Head register
```

```
ac.command           = 0xEC;          // Command register
```

```
status = ATA_PIO_datain(&ac, 1, buff);
```

```
return status;
```

```
}
```

```

/////////////////////////////////////////////////////////////////
// Function name: ATA_Read_Sector                                   //

```

```
// Function: Executes READ SECTOR(S) command (Protocol:PI, Command:20h).//
// Argument: dev_num : Device selection (0:Master/1:Slave) //
//           lba : LBA //
//           sec_cnt : Number of sectors //
//           buff : Buffer pointer //
// Return value: //
// STATUS_SUCCESS : Normal end //
// STATUS_TIMEOUT_DEVICE_SELECTION : DEVICE SELECTION error end //
// STATUS_TIMEOUT_DRDY1 : DRDY=1 timeout error end //
// STATUS_TIMEOUT_INTRQ : INTRQ timeout error end //
// STATUS_IDE_ERROR : Error end after command execution //
// //
/////////////////////////////////////////////////////////////////
int ATA_Read_Sector(int dev_num, UWORD lba, UWORD sec_cnt, void *buff)
{
    int status;
    ATA_COMMAND ac;

    ac.features = 0x00; // Features register
    ac.sector_count = sector_count; // SectorCount register
    ac.sector_number = (lba & 0xFF); // SectorNumber register
    ac.cylinder_low = (lba>>8 & 0xFF); // CylinderLow register
    ac.cylinder_high = (lba>>16 & 0xFF); // CylinderHigh register
    ac.device_head = 0x40|(dev_num<<4)|(lba>>24 & 0x0F); // Device/Head register
    ac.command = 0x20; // Command register

    status = ATA_PIO_datain(&ac, sec_cnt, buff);
    return status;
}
```

www.DataSheet4U.com

```
/////////////////////////////////////////////////////////////////
// Function name: ATA_Write_Sector //
// Function: Executes WRITE SECTOR(S) command (Protocol:PO, Command:30h).//
// Argument: dev_num : Device selection (0:Master/1:Slave) //
//           lba : LBA //
//           sec_cnt : Number of sectors //
//           buff : Buffer pointer //
// Return value: //
// STATUS_SUCCESS : Normal end //
// STATUS_TIMEOUT_DEVICE_SELECTION : DEVICE SELECTION error end //
// STATUS_TIMEOUT_BSY0_DRQ0 : BSY=0,DRQ=0 timeout error end //
// STATUS_TIMEOUT_DRDY1 : DRDY=1 timeout error end //
// STATUS_TIMEOUT_INTRQ : INTRQ timeout error end //
// STATUS_IDE_ERROR : Error end after command execution //
// //
/////////////////////////////////////////////////////////////////
int ATA_Write_Sector(int dev_num, UWORD lba, UWORD sec_cnt, void *buff)
{
```

```

int status;
ATA_COMMAND ac;

ac.features      = 0x00;                // Features register
ac.sector_count  = sector_count;        // SectorCount register
ac.sector_number = (lba & 0xFF);        // SectorNumber register
ac.cylinder_low  = (lba>>8 & 0xFF);    // CylinderLow register
ac.cylinder_high = (lba>>16 & 0xFF);    // CylinderHigh register
ac.device_head   = 0x40|(dev_num<<4)|(lba>>24 & 0x0F); // Device/Head register
ac.command       = 0x30;                // Command register

status = ATA_PIO_dataout(&ac, sec_cnt, buff);
return status;
}

```

```

////////////////////////////////////////////////////////////////////////////////////////////////////////////////////////////////
// Function name: ATA_Read_DMA                                                    //
// Function: Executes READ DMA command (Protocol:DM, Command:C8h).                //
// Argument: dev_num : Device selection (0:Master/1:Slave)                        //
//           lba      : LBA                                                       //
//           sec_cnt  : Number of sectors                                         //
// Return value:                                                                    //
//   STATUS_SUCCESS : Normal end                                                  //
//   STATUS_TIMEOUT_DEVICE_SELECTION : DEVICE SELECTION error end                //
//   STATUS_TIMEOUT_BSY0_DRQ0 : BSY=0,DRQ=0 timeout error end                    //
//   STATUS_TIMEOUT_DRDY1 : DRDY=1 timeout error end                             //
//   STATUS_TIMEOUT_INTRQ : INTRQ timeout error end                              //
//   STATUS_TIMEOUT_BMEND : BM timeout error end                                  //
//   STATUS_IDE_ERROR : Error end after command execution                         //
//                                                                                   //

```

www.DataSheet4U.com

```

////////////////////////////////////////////////////////////////////////////////////////////////////////////////////////////////
int ATA_Read_DMA(int dev_num, UWORD lba, UHWORd sec_cnt)
{
    int status;
    ATA_COMMAND ac;

    ac.features      = 0x00;                // Features register
    ac.sector_count  = sector_count;        // SectorCount register
    ac.sector_number = (lba & 0xFF);        // SectorNumber register
    ac.cylinder_low  = (lba>>8 & 0xFF);    // CylinderLow register
    ac.cylinder_high = (lba>>16 & 0xFF);    // CylinderHigh register
    ac.device_head   = 0x40|(dev_num<<4)|(lba>>24 & 0x0F); // Device/Head register
    ac.command       = 0xC8;                // Command register

    status = ATA_DMA(&ac);
    return status;
}

```



```

////////////////////////////////////
// Function name: ATA_Write_DMA //
// Function: Executes WRITE DMA command (Protocol:DM, Command:CAh). //
// Argument: dev_num : Device selection (0:Master/1:Slave) //
//          lba : LBA //
//          sec_cnt : Number of sectors //
// Return value: //
// STATUS_SUCCESS : Normal end //
// STATUS_TIMEOUT_DEVICE_SELECTION : DEVICE SELECTION error end //
// STATUS_TIMEOUT_BSY0_DRQ0 : BSY=0,DRQ=0 timeout error end //
// STATUS_TIMEOUT_DRDY1 : DRDY=1 timeout error end //
// STATUS_TIMEOUT_INTRQ : INTRQ timeout error end //
// STATUS_TIMEOUT_BMEND : BM timeout error end //
// STATUS_IDE_ERROR : Error end after command execution //
// //
////////////////////////////////////
int ATA_Write_DMA(int dev_num, UWORD lba, UWORD sec_cnt)
{
    int status;
    ATA_COMMAND ac;

    ac.features = 0x00; // Features register
    ac.sector_count = sector_count; // SectorCount register
    ac.sector_number = (lba & 0xFF); // SectorNumber register
    ac.cylinder_low = (lba>>8 & 0xFF); // CylinderLow register
    ac.cylinder_high = (lba>>16 & 0xFF); // CylinderHigh register
    ac.device_head = 0x40|(dev_num<<4)|(lba>>24 & 0x0F); // Device/Head register
    ac.command = 0xCA; // Command register

    status = ATA_DMA(&ac);
    return status;
}

////////////////////////////////////
// Protocol execution function //
////////////////////////////////////

////////////////////////////////////
// Function name: ATA_Device_Selection //
// Function: Executes device selection protocol. //
// Argument: dev_num : (0:Master / 1:Slave) //
// Return value: //
// STATUS_SUCCESS : Normal end //
// STATUS_TIMEOUT_BSY0_DRQ0 : BSY=0,DRQ=0 timeout error end //
// //
////////////////////////////////////
int ATA_Device_Selection(int dev_num)
{

```

```

int status;

status = Wait_IDE_BSY0_DRQ0();           // Wait until BSY=0, DRQ=0
if ( status != 0 ) {
    return STATUS_TIMEOUT_BSY0_DRQ0;     // Timeout error end
}

*IDEREG_DEVICE_HEAD = dev_num << 4;     // Device selection
wait(TIMER400ns);                       // Wait 400 ns

status = Wait_IDE_BSY0_DRQ0();           // Wait until BSY=0, DRQ=0
if ( status != 0 ) {
    return STATUS_TIMEOUT_BSY0_DRQ0;     // Timeout error end
}

return STATUS_SUCCESS;                   // Normal end
}

////////////////////////////////////////////////////////////////////////////////////////////////////////////////////////////////
// Function name: ATA_PIO_datain           //
// Function: Executes PIO data in command protocol. //
// Argument: atacom : ATA_COMMAND structure pointer //
//          sector_count : Number of sectors //
//          buff : Buffer pointer //
// Return value: //
// STATUS_SUCCESS : Normal end //
// STATUS_TIMEOUT_DEVICE_SELECTION : DEVICE SELECTION error end //
// STATUS_TIMEOUT_DRDY1 : DRDY=1 timeout error end //
// STATUS_TIMEOUT_INTRQ : INTRQ timeout error end //
// STATUS_IDE_ERROR : Error end after command execution //
// //
////////////////////////////////////////////////////////////////////////////////////////////////////////////////////////////////
int ATA_PIO_datain(ATA_COMMAND *atacom, UWORD sector_count, void *buff)
{
    UBYTE dev, idestat;
    UWORD *buffp;
    int i, j, status;

    buffp = (UWORD*)buff;
    dev = ( atacom->device_head >> 4 ) & 1;

    status = ATA_Device_Selection(dev);    // DEVICE SELECTION
    if ( status != 0 ) {
        return STATUS_TIMEOUT_DEVICE_SELECTION; // DEVICE SELECTION timeout
    }

    *IDEREG_FEATURES      = atacom->features; // Features register
    *IDEREG_SECTOR_COUNT  = atacom->sector_count; // SectorCount register

```

```

*IDEREG_SECTOR_NUMBER = atacom->sector_number; // SectorNumber register
*IDEREG_CYLINDER_LOW  = atacom->cylinder_low;  // CylinderLow register
*IDEREG_CYLINDER_HIGH = atacom->cylinder_high; // CylinderHigh register

status = Wait_IDE_DRDY1(); // Loop until DRDY=1
if ( status != 0 ) {
    return STATUS_TIMEOUT_DRDY1 // DRDY1 timeout
}

*IDEREG_COMMAND = atacom->command; // Command register
wait(TIMER400ns); // Wait 400 ns

for ( i=0; i<sector_count; i++ ) {
    status = Wait_IDE_INTRQ(); // Wait for INTRQ assert
    if ( status != 0 ) {
        return STATUS_TIMEOUT_INTRQ; // INTRQ timeout error
    }

    idestat = *IDEREG_STATUS; // Status register read (INTRQ clear)

    for ( j=0; j<128; j++ ) { // Data read
        *bufp = *IDEREG_DATA;
        bufp++;
    }
}

idestat = *IDEREG_ALTERNATE_STATUS; // Alt Status register empty read
idestat = *IDEREG_STATUS; // Status register read

if ( idestat & IDEREG_ERROR_ERR_BIT ) {
    return STATUS_IDE_ERROR(*IDEREG_ERROR); // Error end (after command execution)
}
return STATUS_SUCCESS; // Normal end
}

////////////////////////////////////
// Function name: ATA_PIO_dataout //
// Function: Executes PIO data out command protocol. //
// Argument: atacom : ATA_COMMAND structure pointer //
//           sector_count : Number of sectors //
//           buff : Buffer pointer //
// Return value: //
// STATUS_SUCCESS : Normal end //
// STATUS_TIMEOUT_DEVICE_SELECTION : DEVICE SELECTION error end //
// STATUS_TIMEOUT_BSY0_DRQ0 : BSY=0,DRQ=0 timeout error end //
// STATUS_TIMEOUT_DRDY1 : DRDY=1 timeout error end //
// STATUS_TIMEOUT_INTRQ : INTRQ timeout error end //
// STATUS_IDE_ERROR : Error end after command execution //

```

```

//
//
//
int ATA_PIO_dataout(ATA_COMMAND *atacom, UWORD sector_count, void *buff)
{
    UBYTE dev, idestat;
    UWORD *bufp;
    int i, j, status;

    bufp = (UWORD*)buff;
    dev = ( atacom->device_head >> 4 ) & 1;

    status = ATA_Device_Selection(dev);           // DEVICE SELECTION
    if ( status != 0 ) {
        return STATUS_TIMEOUT_DEVICE_SELECTION;  // DEVICE SELECTION timeout
    }

    *IDEREG_FEATURES      = atacom->features;    // Features register
    *IDEREG_SECTOR_COUNT  = atacom->sector_count; // SectorCount register
    *IDEREG_SECTOR_NUMBER = atacom->sector_number; // SectorNumber register
    *IDEREG_CYLINDER_LOW  = atacom->cylinder_low; // CylinderLow register
    *IDEREG_CYLINDER_HIGH = atacom->cylinder_high; // CylinderHigh register

    status = Wait_IDE_DRDY1();                   // Loop until DRDY=1
    if ( status != 0 ) {
        return STATUS_TIMEOUT_DRDY1;            // DRDY timeout
    }

    *IDEREG_COMMAND = atacom->command;          // Command register
    wait(TIMER400ns);                          // Wait 400 ns

    status = Wait_IDE_BSY0_DRQ0();              // Wait until BSY=0, DRQ=0
    if ( status != 0 ) {
        return STATUS_TIMEOUT_BSY0_DRQ0;       // BSY timeout error end
    }

    for ( i=0; i<sector_count; i++ ) {
        for ( j=0; j<128; j++ ) {               // Data write
            *IDEREG_DATA = *bufp;
            bufp++;
        }
        status = Wait_IDE_INTRQ();              // Wait for INTRQ assert
        if ( status != 0 ) {
            return STATUS_TIMEOUT_INTRQ;       // INTRQ timeout error
        }
        idestat = *IDEREG_STATUS;              // Status register read (INTRQ clear)
    }

    if ( idestat & IDEREG_ERROR_ERR_BIT ) {

```

```

        return STATUS_IDE_ERROR(*IDEREG_ERROR);    // Error end (after command execution)
    }
    return STATUS_SUCCESS;                        // Normal end
}

```

```

////////////////////////////////////////////////////////////////////////////////////////////////////////////////////////////////
// Function name: ATA_PIO_nondata                                                    //
// Function: Executes PIO non data command protocol.                               //
// Argument: atacom : ATA_COMMAND structure pointer                                //
// Return value:                                                                      //
//     STATUS_SUCCESS : Normal end                                                  //
//     STATUS_TIMEOUT_DEVICE_SELECTION : DEVICE SELECTION error end                //
//     STATUS_TIMEOUT_DRDY1 : DRDY=1 timeout error end                             //
//     STATUS_TIMEOUT_INTRQ : INTRQ timeout error end                              //
//     STATUS_IDE_ERROR : Error end after command execution                         //
//                                                                                   //
////////////////////////////////////////////////////////////////////////////////////////////////////////////////////////////////

```

```

int ATA_PIO_nondata(ATA_COMMAND *atacom)
{
    int status;
    UBYTE dev, idestat;

    dev = ( atacom->device_head >> 4 ) & 1;
    status = ATA_Device_Selection(dev);      // DEVICE SELECTION
    if ( status != 0 ) {
        return STATUS_TIMEOUT_DEVICE_SELECTION; // DEVICE SELECTION timeout
    }

    *IDEREG_FEATURES      = atacom->features; // Features register
    *IDEREG_SECTOR_COUNT  = atacom->sector_count; // SectorCount register
    *IDEREG_SECTOR_NUMBER = atacom->sector_number; // SectorNumber register
    *IDEREG_CYLINDER_LOW  = atacom->cylinder_low; // CylinderLow register
    *IDEREG_CYLINDER_HIGH = atacom->cylinder_high; // CylinderHigh register

    status = Wait_IDE_DRDY1(); // Loop until DRDY=1
    if ( status != 0 ) {
        return STATUS_TIMEOUT_DRDY1; // DRDY timeout
    }

    *IDEREG_COMMAND = atacom->command; // Command register

    wait(TIMER400ns); // Wait 400 ns

    status = Wait_IDE_INTRQ(); // Wait for INTRQ assert
    if ( status != 0 ) {
        return STATUS_TIMEOUT_INTRQ; // INTRQ timeout error
    }
}

```

```

idestat = *IDEREG_ALT_STATUS;           // Alt Status register empty read
idestat = *IDEREG_STATUS;              // Status register read

if ( idestat & IDEREG_ERROR_ERR_BIT ) {
    return STATUS_IDE_ERROR(*IDEREG_ERROR); // Error end (after command execution)
}

return STATUS_SUCCESS;                  // Normal end
}

```

```

////////////////////////////////////////////////////////////////////////////////////////////////////////////////////////////////
// Function name: ATA_DMA                //
// Function: Executes DMA command protocol. //
// Argument: atacom : ATA_COMMAND structure pointer //
// Return value:                          //
// STATUS_SUCCESS : Normal end            //
// STATUS_TIMEOUT_DEVICE_SELECTION : DEVICE SELECTION error end //
// STATUS_TIMEOUT_BSY0_DRQ0 : BSY=0,DRQ=0 timeout error end //
// STATUS_TIMEOUT_DRDY1 : DRDY=1 timeout error end //
// STATUS_TIMEOUT_INTRQ : INTRQ timeout error end //
// STATUS_TIMEOUT_BMEND : BM timeout error end //
// STATUS_IDE_ERROR : Error end after command execution //
//                                          //
////////////////////////////////////////////////////////////////////////////////////////////////////////////////////////////////

```

```

int ATA_DMA(ATA_COMMAND *atacom)
{
    int status;
    UBYTE dev, idestat;

    dev = ( atacom->device_head >> 4 ) & 1;
    status = ATA_Device_Selection(dev); // DEVICE SELECTION
    if ( status != 0 ) {
        return STATUS_TIMEOUT_DEVICE_SELECTION; // DEVICE SELECTION timeout
    }

    *IDEREG_FEATURES      = atacom->features; // Features register
    *IDEREG_SECTOR_COUNT  = atacom->sector_count; // SectorCount register
    *IDEREG_SECTOR_NUMBER = atacom->sector_number; // SectorNumber register
    *IDEREG_CYL_LOW       = atacom->cylinder_low; // CylinderLow register
    *IDEREG_CYL_HIGH      = atacom->cylinder_high; // CylinderHigh register

    status = Wait_IDE_DRDY1(); // Loop until DRDY=1
    if ( status != 0 ) {
        return STATUS_TIMEOUT_DRDY1; // DRDY timeout
    }

    *IDEREG_COMMAND = atacom->command; // Command register
}

```

```

wait(TIMER400ns); // Wait 400 ns
idestat = *IDEREG_ALT_STATUS; // Alt Status register empty read

*IDEREG_BUSMASTER_START_STOP |= 0x01; // Bus Master Start
status = Wait_IDE_BMEND();
if ( status != 0 ) {
    return STATUS_TIMEOUT_BMEND; // BMEND timeout error end
}

status = Wait_IDE_INTRQ(); // Wait for INTRQ assert
if ( status != 0 ) {
    return STATUS_TIMEOUT_INTRQ; // INTRQ timeout error end
}

idestat = *IDEREG_ALT_STATUS; // Alt Status register empty read
idestat = *IDEREG_STATUS; // Status register read

if ( idestat & IDEREG_ERROR_ERR_BIT ) {
    return STATUS_IDE_ERROR(*IDEREG_ERROR); // Error end (after command execution)
}
return STATUS_SUCCESS; // Normal end
}

/////////////////////////////////////////////////////////////////
// Function name: ATA_Soft_Reset //
// Function: Performs software reset. //
// Argument: None //
// Return value: //
// STATUS_SUCCESS : Normal end //
// STATUS_TIMEOUT_BSY0 : BSY=0 timeout error end //
// //
/////////////////////////////////////////////////////////////////
int ATA_soft_reset(void)
{
    int status;

    *IDEREG_DEVICE_CONTROL = 0x04; // Reset execution
    wait(TIMER5ms); // Wait 5 ms
    *IDEREG_DEVICE_CONTROL = 0x00; // Reset release
    wait(TIMER5ms); // Wait 5 ms

    status = Wait_IDE_BSY0(); // Wait until BSY=0
    if ( status != 0 ) {
        return STATUS_TIMEOUT_BSY0; // Timeout error end
    }
    return STATUS_SUCCESS;
}

```

```

/////////////////////////////////////////////////////////////////
// Function name: main //
// Function: Accesses IDE HDD via PCI bus and PCI-IDE ASIC board. //
// Argument: None //
// Return value: 0: Normal end //
// Overview: Issues IDLE IMMEDIATE, IDENTIFY DEVICE, SET FEATURE, READ //
//           SECTOR(S), WRITE SECTOR(S), READ DMA, and WRITE DMA commands. //
// // //
/////////////////////////////////////////////////////////////////

int main(void)
{
    int status;
    UBYTE wbuff[4096], rbuff[4096];
    DISCRIPTOR_TABLE* dsc_tbl;

    ///////////////////////////////////////////////////////////////////
    // System initialization //
    ///////////////////////////////////////////////////////////////////
    // Initializes PCI Host Bridge Macro.
    PCI_HBM_Init();

    // Sets initialization of PCI-IDE ASIC board.
    PCI_Config_BaseAddressInit();
    PCI_Config_ModeInit();

    ATA_soft_reset(void); // Soft reset

    ///////////////////////////////////////////////////////////////////
    // Issue ATA command to IDE HDD //
    ///////////////////////////////////////////////////////////////////

    ///////////////////////////////////////////////////////////////////
    // IDLE IMMEDIATE //
    ///////////////////////////////////////////////////////////////////
    ATA_Idle_Immediate(0); // Issues IDLE IMMEDIATE command.

    ///////////////////////////////////////////////////////////////////
    // IDENTIFY DEVICE //
    ///////////////////////////////////////////////////////////////////
    ATA_Identify_Device( // Issues IDENTIFY DEVICE command.
        0, // Master Device
        buff // Buffer storing results
    );

    ///////////////////////////////////////////////////////////////////
    // PIO transfer preparation //
    ///////////////////////////////////////////////////////////////////

```



```

// Sets transfer mode to PIO transfer Mode0 using SET_FEATURE command.
Set_Transfer_Mode(0, PIO_MODE0);

// Sets PIO Timing register of configuration register of
// PCI-IDE ASIC board.
Set_PIO_Timing(IDE_PIO_TIMING_IDE33MHz_MODE0);

// Buffer initialization
InitBuffer(wbuff, 4096);

//////////
// PIO transfer //
//////////
ATA_Write_Sector( // Issues WRITE SECTOR command.
    0, // Master Device
    0, // LBA 0
    1, // 1 Sector
    wbuff // Buffer storing written contents
);

ATA_Read_Sector( // Issues READ SECTOR command.
    0, // Master Device
    0, // LBA 0
    1, // 1 Sector
    rbuff // Buffer storing read results
);

status = memcmp(wbuff, rbuff, 512);
if ( status != 0 ) {
    printf("Verify Error!: WRITE SECTOR(S), READ SECTOR(S)\n");
}

//////////
// UltraDMA transfer preparation //
//////////
// Sets transfer mode to UltraDMA transfer Mode0 using SET_FEATURE command.
Set_Transfer_Mode(0, UDMA_MODE0);

// Sets UltraDMA Timing1 and UltraDMA Timing2 registers of configuration
// register of PCI-IDE ASIC board.
Set_UDMA_Timing(IDE_UDMA_TIMING1_IDE33MHz_MODE0, IDE_UDMA_TIMING2_IDE33MHz_MODE0);

//////////
// PCI->IDE UltraDMA transfer //
//////////

// Sets descriptor table referenced by PCI-IDE ASIC board during UltraDMA transfer.
dsc_tbl = (DISCRIPTOR_TABLE*)(BASE_ADDRESS_SDRAM + 0x02000000)

```

```

dsc_tbl->transfer_address    = BASE_ADDRESS_SDRAM;
dsc_tbl->transfer_byte       = 0x1000;           // = 4096byte = 8Sector
dsc_tbl->next_table_address  = 0x00000001;      // Last table
*IDEREG_DSCTBL_START_ADDRESS = dsc_tbl;

// Sets transfer direction of UltraDMA transfer.
*IDEREG_BUSMASTER_START_STOP &= 0xFFFFFEFF;   // Ultra DMA (PCI->IDE)

// Buffer initialization
InitBuffer((UBYTE*)dsc_tbl->transfer_address, 512*8);

// Issues command of UltraDMA transfer.
ATA_Write_DMA(
    0,          // Master Device
    0,          // LBA 0
    8,          // 8 Sector
);

//////////
// PCI<-IDE UltraDMA transfer //
//////////

// Sets descriptor table referenced by device during UltraDMA transfer.
dsc_tbl->transfer_address    = BASE_ADDRESS_SDRAM + 0x01000000;
dsc_tbl->transfer_byte       = 0x1000;           // = 4096byte = 8Sector
dsc_tbl->next_table_address  = 0x00000001;      // Last table
*IDEREG_DSCTBL_START_ADDRESS = dsc_tbl;

// Sets transfer direction of UltraDMA transfer.
*IDEREG_BUSMASTER_START_STOP |= 0x00000100;    // Ultra DMA (PCI<-IDE)

// Issues command of UltraDMA transfer.
ATA_Read_DMA(
    0,          // Master Device
    0,          // LBA 0
    8,          // 8 Sector
);

status = memcmp(
    (UBYTE*) (BASE_ADDRESS_SDRAM),
    (UBYTE*) (BASE_ADDRESS_SDRAM+0x01000000),
    512*8);
if ( status != 0 ) {
    printf("Verify Error!: WRITE DMA, READ DMA\n");
}

return 0;
}

```

www.DataSheet4U.com

Figure 5-6. IDE_Write_DMA Function

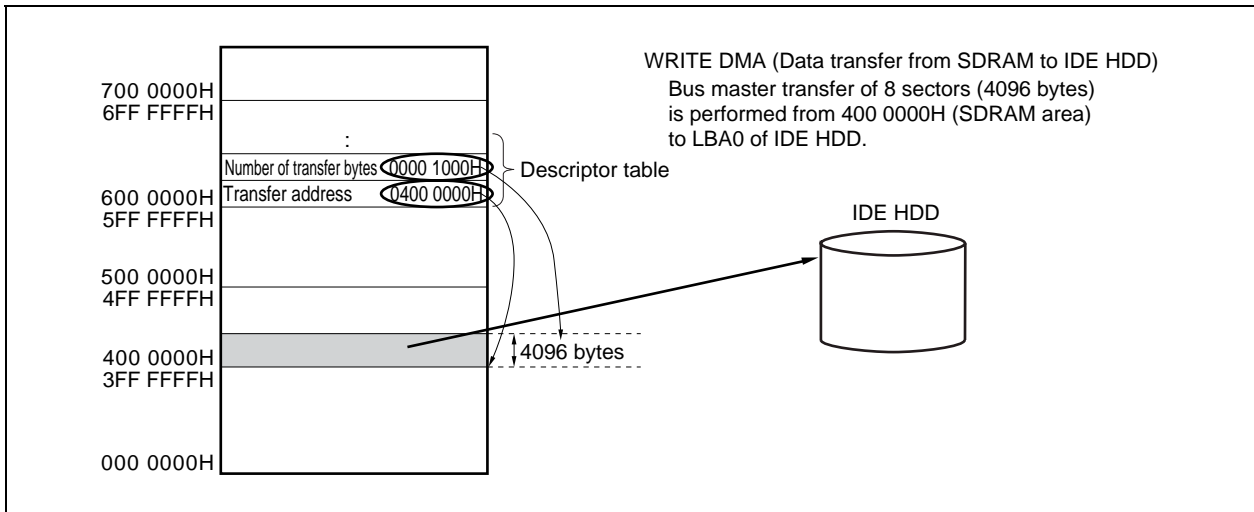
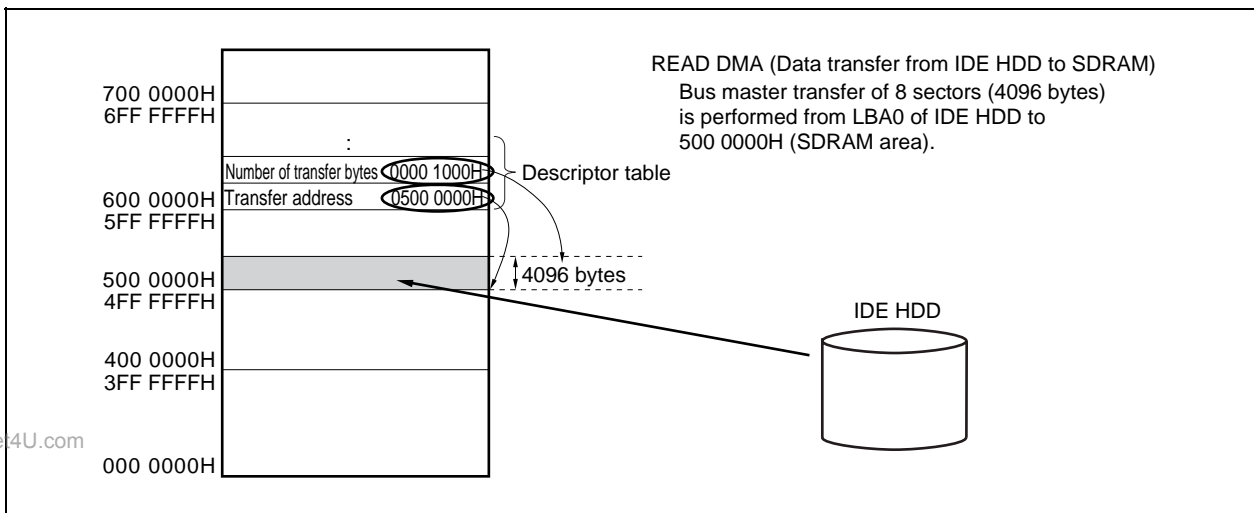

Figure 5-7. IDE_Read_DMA Function



www.DataSheet4U.com