

Description

The μPD71011 is a clock pulse generator/driver for the V20®/V30® microprocessors and their peripherals using NEC's high-speed CMOS technology.

Features

- CMOS technology
- Clock pulse generator/driver for μPD70108/70116 or other CMOS or NMOS CPUs and their peripherals
- 50% duty cycle
- Frequency source can be crystal or external clock input
- Reset signal with Schmitt-trigger circuit for CPU or peripherals
- Bus ready signal with two-bus system synchronization
- Clock synchronization with other μPD71011s
- Single +5-volt ±10% power supply
- Industrial temperature range: -40 to +85°C

Ordering Information

Part Number	Maximum Clockout		Package
	Frequency		
μPD71011C-8	8 MHz		18-pin plastic DIP
C-10	10 MHz		
G-8	8 MHz		20-pin plastic SOP

Pin Configurations

18-Pin Plastic DIP

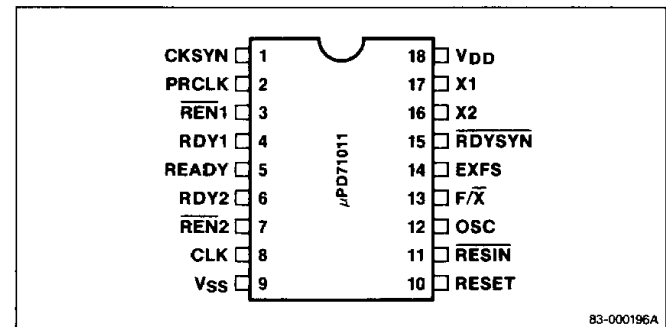

20-Pin Plastic SOP

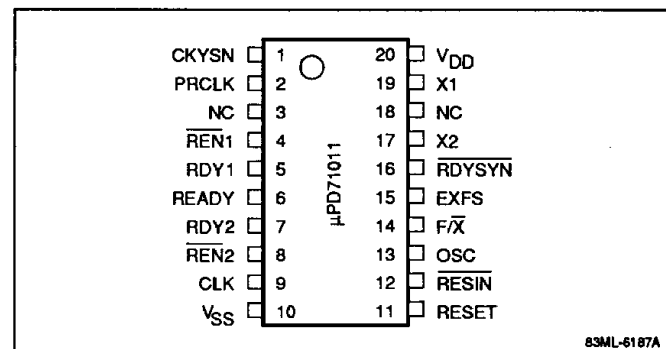

5a

V20 and V30 are registered trademarks of NEC Corporation

Pin Identification

Symbol	Function
CKSYN	Clock synchronization input
PRCLK	Peripheral clock output
$\overline{REN1}$	Bus ready enable input 1
RDY1	Bus ready input 1
READY	Ready output
RDY2	Bus ready input 2
$\overline{REN2}$	Bus ready enable input 2
CLK	Processor clock output
V_{SS}	Ground potential
RESET	Reset output
\overline{RESIN}	Reset input
OSC	Oscillator output
F/\overline{X}	External frequency source/crystal select input
EXFS	External frequency source input
RDYSYN	Ready synchronization select input
X2	Crystal input
X1	Crystal input
V_{DD}	+5-volt power supply
NC	No connection

PIN FUNCTIONS

X1, X2 (Crystal)

When F/\overline{X} is low, a crystal connected to X1 and X2 will be the frequency source for a CPU and its peripherals. The crystal frequency should be two times the frequency of CLK.

EXFS (External Frequency Source)

EXFS input is the external frequency input in the external TTL-frequency source mode (F/\overline{X} high). A square TTL-level clock signal two times the frequency of CLK's output should be used for the source.

F/\overline{X} (Frequency/Crystal Select)

F/\overline{X} input selects whether an external TTL-type input or an external crystal input is the frequency source of the CLK output. When F/\overline{X} is low, CLK is generated from the crystal connected to X1 and X2. When F/\overline{X} is high, CLK is generated from an external TTL-level frequency input on the EXFS pin. At the same time, the internal oscillator circuit will go into stop mode and the OSC output will be high.

CLK (Processor Clock)

The CLK output supplies the CPU and its local bus peripherals' clocks. CLK is a 50-percent duty cycle clock of one-half the frequency of the external frequency source. The CLK output is +0.4 V higher than the other outputs.

PRCLK (Peripheral Clock)

The PRCLK output supplies a 50-percent duty cycle clock at one-half the frequency of CLK to drive peripheral devices.

OSC (Oscillator)

OSC outputs a signal at the same frequency as the crystal input. When EXFS is selected, the OSC output is powered down, and its output will be a high.

CKSYN (Clock Synchronization)

CKSYN synchronizes one μPD71011 to other μPD71011s. A high level at CKSYN resets the internal counter, and a low level enables it to count.

\overline{RESIN} (Reset)

This Schmitt-trigger input generates the RESET output. It is used as a power-on reset.

RESET (Reset)

This output is a reset signal for the CPU. Reset timing is provided by the \overline{RESIN} input to a Schmitt-trigger input gate and a flip-flop which will synchronize the reset timing to the falling edge of CLK. Power-on reset can be provided by a simple RC circuit on the \overline{RESIN} input.

RDY1, RDY2 (Bus Ready)

A peripheral device sends RDY1 or RDY2 to signal that the data on the system bus has been received or is ready to be sent. $\overline{REN1}$ and $\overline{REN2}$ enable the RDY1 or RDY2 signals.

$\overline{REN1}$, $\overline{REN2}$ (Bus Ready Enable)

$\overline{REN1}$ and $\overline{REN2}$ qualify their respective RDY inputs.

RDYSYN (Ready Synchronization Select)

RDYSYN selects the mode of READY signal synchronization. A low-level signal makes the synchronization a two-step process. This is used when RDY1 and RDY2 inputs are not synchronized to CLK. A high-level signal makes synchronization a one-step process. This is used when RDY1 and RDY2 are synchronized to CLK. See block diagram.

READY (Ready)

The READY signal to the processor is synchronized by the RDY inputs to the processor CLK. READY is cleared after the RDY signal goes low and the guaranteed hold time of the processor has been met.

Crystal

The oscillator circuit of the μPD71011 works with a parallel-resonant, fundamental mode, "AT cut" crystal connected to pins X1 and X2.

Figure 1 shows the recommended circuit configuration. Capacitors C1 and C2 are required for frequency stability. The values of C1 and C2 ($C_1 = C_2$) can be calculated from the load capacitance (C_L) specified by the crystal manufacturer.

$$C_L = \frac{C_1 \times C_2}{C_1 + C_2} + C_S$$

Where C_S is any stray capacitance in parallel with the crystal, such as the μPD71011 input capacitance C_{IN} .

Figure 1. Crystal Configuration Circuit

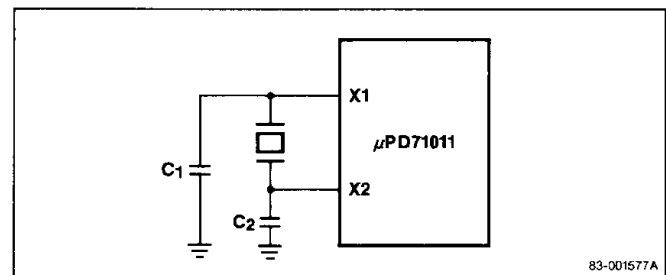

83-001577A

μPD71011 Block Diagram

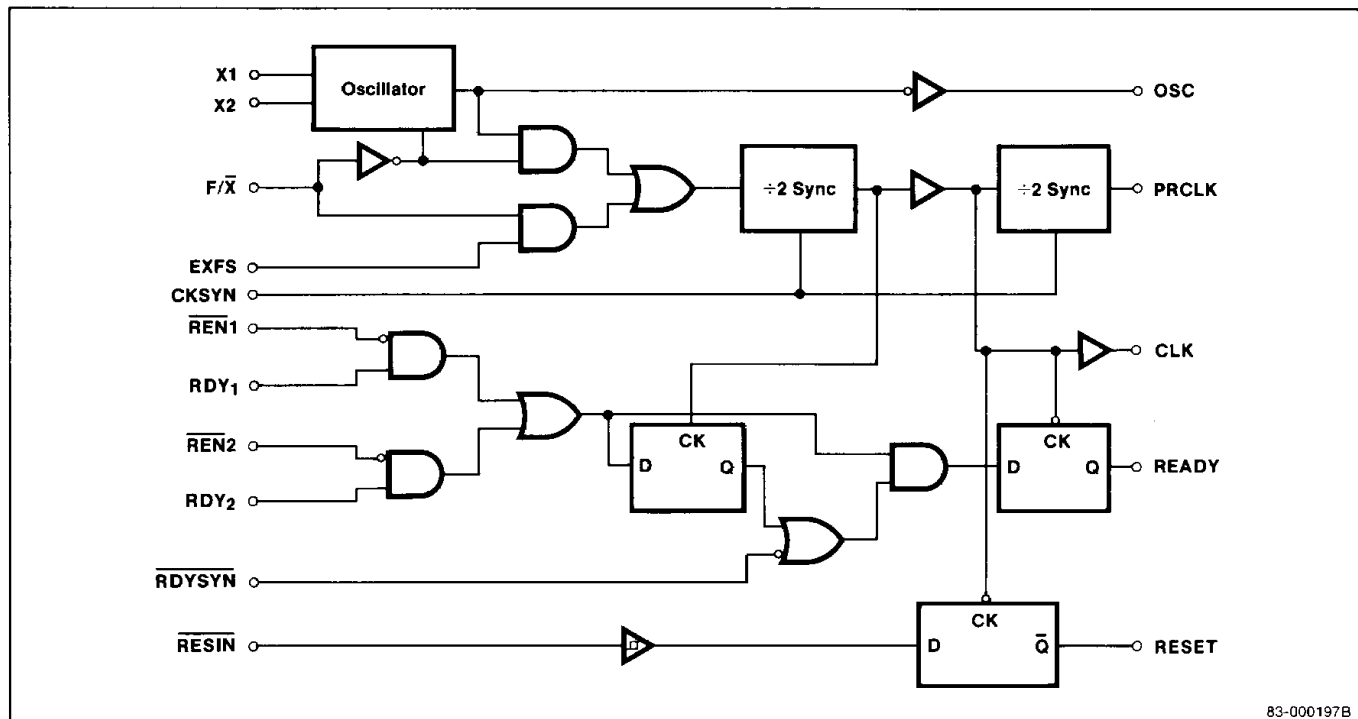

83-000197B

5a

Absolute Maximum Ratings

T_A = 25°C; V_{SS} = 0 V

Power supply voltage, V _{DD}	- 0.5 to + 7.0 V
Input voltage, V _I	- 1.0 V to V _{DD} + 1.0 V
Output voltage, V _O	- 0.5 V to V _{DD} + 0.5 V
Operating temperature, T _{OPT}	- 40 to +85°C
Storage temperature, T _{STG}	- 65 to +150°C
Power dissipation, P _D (DIP)	500 mW
Power dissipation, P _D (SO package)	200 mW

Exposure to Absolute Maximum Ratings for extended periods may affect device reliability; exceeding the ratings could cause permanent damage. The device should be operated within the limits specified under DC and AC Characteristics.

Capacitance

T_A = 25°C; V_{DD} = +5 V

Parameter	Symbol	Min	Max	Unit	Conditions
Input capacitance	C _{IN}		12	pF	f _C = 1 MHz

DC Characteristics

T_A = -40 to +85°C; V_{DD} = 5 V ±10%

Parameter	Symbol	Min	Max	Unit	Conditions
Input voltage, high	V _{IH}	2.2		V	
			2.6	V	RESIN input
Input voltage, low	V _{IL}		0.8	V	
Output voltage, high	V _{OH}	V _{DD} - 0.4		V	CLK output, I _{OH} = -4 mA
		V _{DD} - 0.8		V	I _{OH} = -4 mA
Output voltage, low	V _{OL}		0.45	V	I _{OL} = 4 mA
Input leakage current	I _{IN}	-1.0	1.0	μA	
		-400	1.0	μA	RDYSYN input
RESIN input hysteresis		0.20		V	
Power supply current (static)	I _{DD}		200	μA	
Power supply current (dynamic)	I _{DDdyn}		30	mA	f _{IN} = 20 MHz

AC Characteristics

f_{OSC} = 10 MHz; T_A -40 to +85°C; V_{DD} = +5 V ±10%
 f_{OSC} = 16 MHz; T_A -10 to +70°C; V_{DD} = +5 V ±5%
 f_{OSC} = 20 MHz; T_A -10 to +70°C; V_{DD} = +5 V ±5%

Parameter	Symbol	μPD71011		μPD71011-10		Unit	Conditions
		Min	Max	Min	Max		
Clock Timing							
EXFS input cycle time	t _{CYFS}	50		50		ns	
EXFS pulse width, high	t _{PWFH}	20		20		ns	2.2 V measurement point
EXFS pulse width, low	t _{PWFL}	20		20		ns	0.8 V measurement point
OSC cycle time	f _{OSC}	8	20	8	20	MHz	from EXFS
CKSYN pulse width	t _{PWCT}	2t _{CYFS}		2t _{CYFS}		ns	
CKSYN setup time	t _{HFSCTK}	20		20		ns	
CKSYN hold time	t _{SCTFS}	20		20		ns	
CLK cycle time	t _{CYCK}	125		100		ns	
CLK pulse width, high	t _{PWCKH}	80		41		ns	3.0 V, f _{OSC} = 10 MHz, f _{OSC} = 20 MHz
		50				ns	3.0 V, f _{OSC} = 16 MHz
CLK pulse width, low	t _{PWCKL}	90		49		ns	1.5 V, f _{OSC} = 10 MHz, f _{OSC} = 20 MHz
		60				ns	1.5 V, f _{OSC} = 16 MHz
CLK rise time	t _{LHCK}		10		5	ns	1.5 → 3.0 V, f _{OSC} = 10 MHz, f _{OSC} = 20 MHz
			8			ns	1.5 → 3.0 V, f _{OSC} = 16 MHz
CLK fall time	t _{HLCK}		10		5	ns	3.0 → 1.5 V, f _{OSC} = 10 MHz, f _{OSC} = 20 MHz
			7			ns	3.0 → 1.5 V, f _{OSC} = 16 MHz
OSC to CLK ↑ delay	t _{DCK}	2	30	2	30	ns	CLK ↑
OSC to CLK ↓ delay	t _{DCK}	-6	28	-6	28	ns	CLK ↓
PRCLK cycle time	t _{CYPRK}	250		200		ns	

AC Characteristics (cont)

Parameter	Symbol	μPD71011		μPD71011-10		Unit	Conditions
		Min	Max	Min	Max		
Clock Timing (cont)							
PRCLK pulse width, high	t _{PWPRKH}	t _{CYCK} - 20		t _{CYCK} - 20		ns	
PRCLK pulse width, low	t _{PWPRKL}	t _{CYCK} - 20		t _{CYCK} - 20		ns	
PRCLK ↑ delay from CLK ↓	t _{DPRKH}		22		22	ns	
PRCLK ↓ delay from CLK ↓	t _{DPRKL}		22		22	ns	
Reset Timing							
RESIN setup to CLK ↓	t _{SRICK}	65		65		ns	
RESIN hold from CLK ↓	t _{HCKRI}	20		20		ns	
RESET delay from CLK ↓	t _{DCKRS}		40		20	ns	
Ready Timing (RDYSYN = 'H')							
REN1, 2 setup to RDY1, 2	t _{SRERY}	15		15		ns	
REN1, 2 hold from CLK ↓	t _{HCKRE}	0		0		ns	
RDY1, 2 setup to CLK ↓	t _{SRYCK}	35		35		ns	RDYSYN high
RDY1, 2 hold from CLK ↓	t _{HCKRY}	0		0		ns	
RDYSYN setup to CLK ↓	t _{SRYSCK}	50		50		ns	
RDYSYN hold from	t _{HCKRYS}	0		0		ns	
READY output delay from CLK ↓	t _{DCKRDY}		8		8	ns	READY ↑
			8		8	ns	READY ↓
Ready Timing (RDYSYN = 'L')							
REN1, 2 setup to RDY1, 2	t _{SRERY}	15		15		ns	
REN1, 2 hold from CLK ↓	t _{HCKRE}	0		0		ns	
RDY1, 2 setup to CLK	t _{SRYCK}	35		35		ns	RDYSYN low
RDY1, 2 hold from CLK ↓	t _{HCKRY}	0		0		ns	
RDYSYN setup to CLK ↓	t _{SRYSCK}	50		50		ns	
RDYSYN hold from CLK ↓	t _{HCKRYS}	0		0		ns	
READY output delay from CLK ↓	t _{DCKRDY}		8		8	ns	READY ↑
			8		8	ns	READY ↓
Output Pin Timing							
Rise time	t _{LH}		20		20	ns	0.8 → 2.0 V
Fall time	t _{HL}		12		12	ns	2.0 → 0.8 V

5a

Timing Waveforms

AC Test Input (except RESIN)

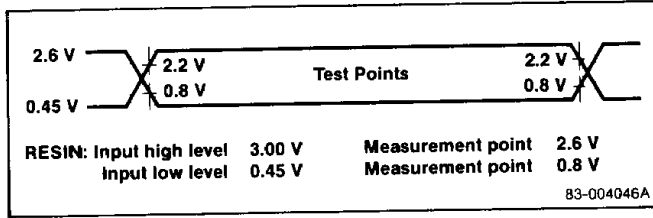

AC Test Output (CLK)

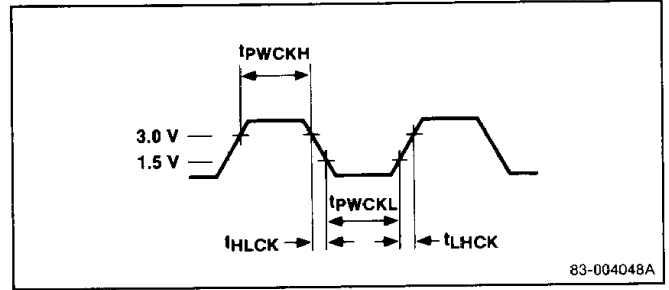

AC Test Output (except CLK)

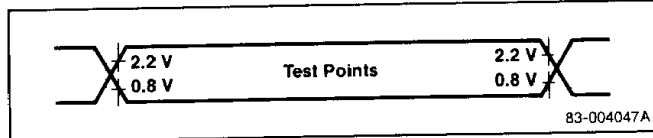

Clock Output

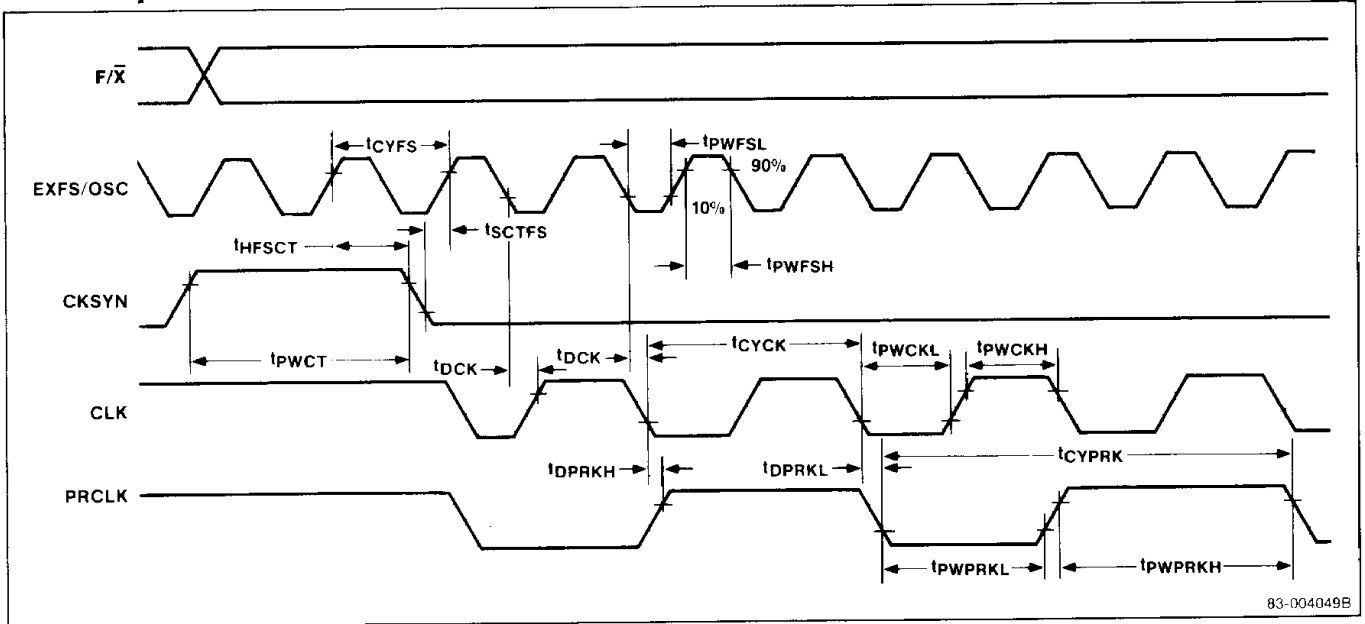

Timing Waveforms (cont)

RESET Pin

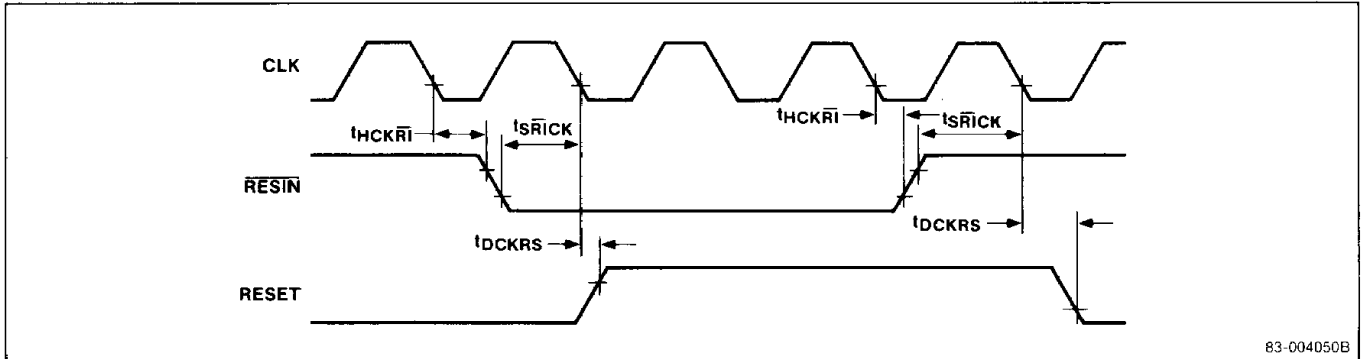

READY Pin ($\overline{RDYSYN} = 'H'$)

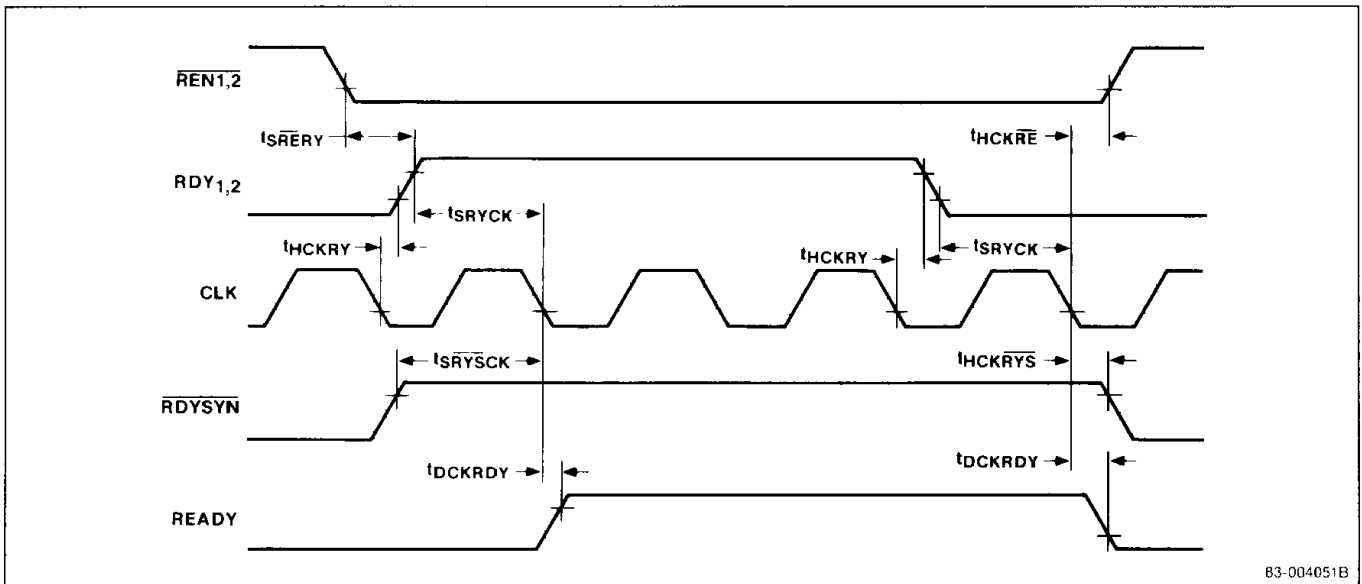

5a

Timing Waveforms (cont)

READY Pin ($\overline{RDYSYN} = 'L'$)

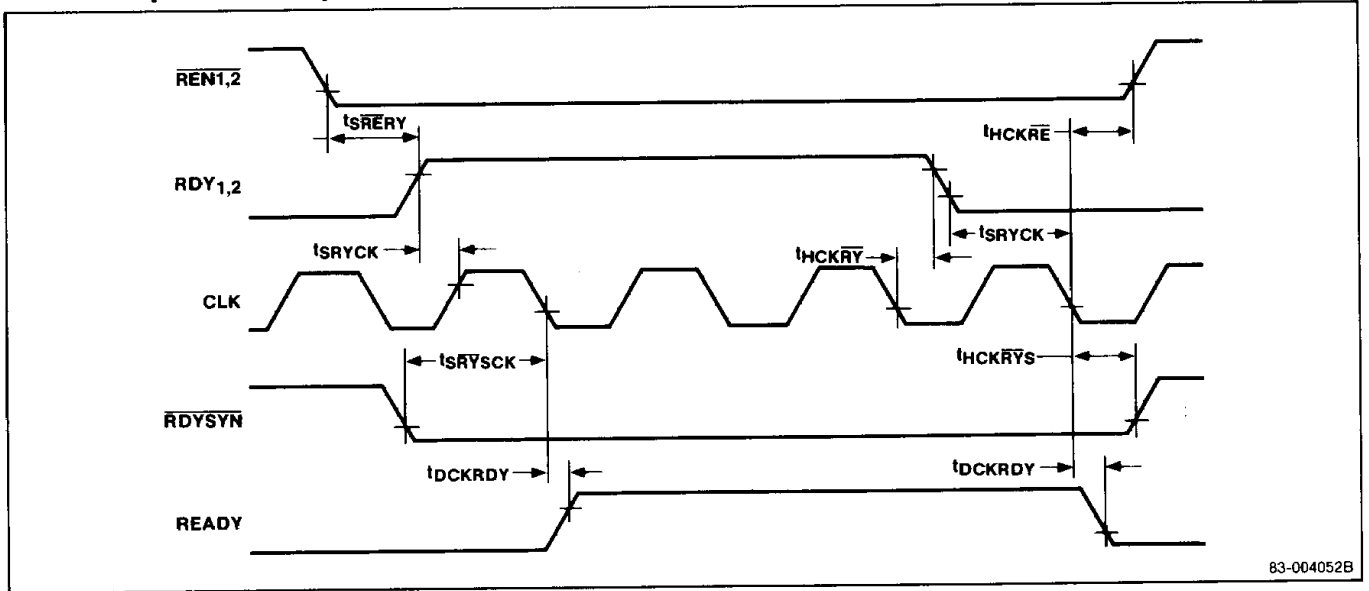

**Test Circuit for CLK High or Low Time
(in Crystal Oscillation Mode)**

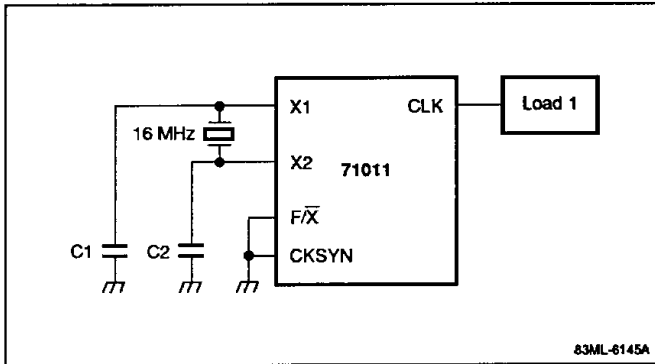

**Test Circuit for CLK High or Low Time
(in EXFS Oscillation Mode)**

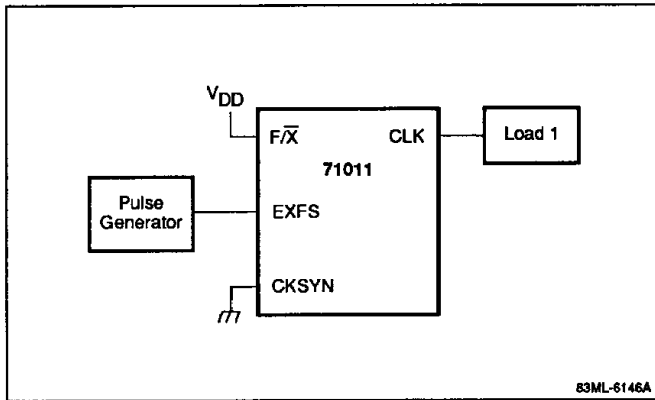

**Test Circuit for CLK to READY
(in Crystal Oscillation Mode)**

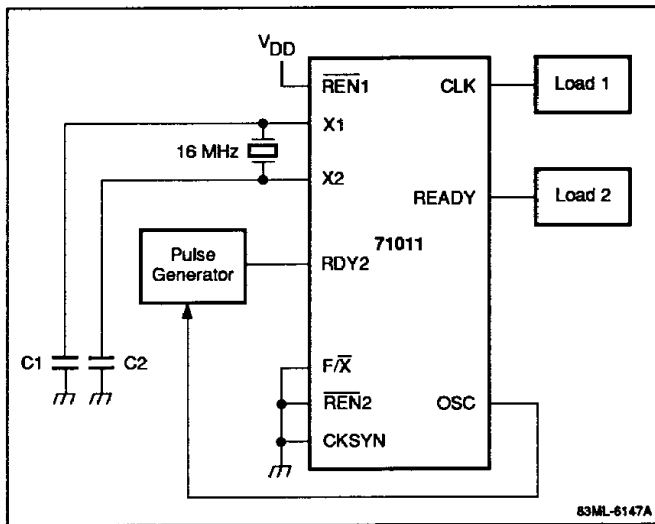

**Test Circuit for CLK to READY
(in EXFS Oscillation Mode)**

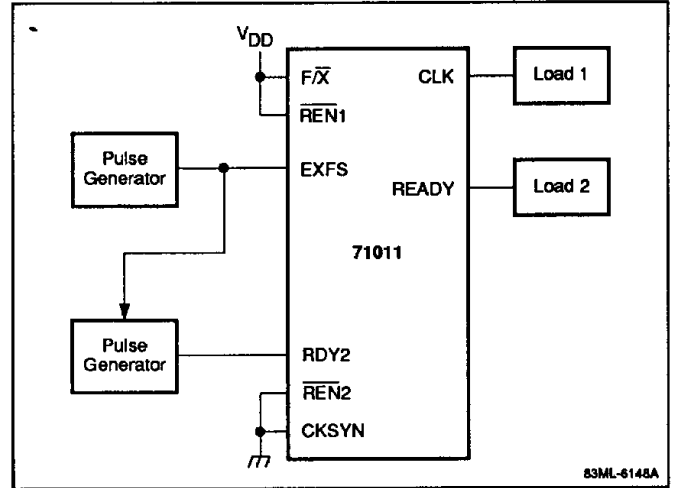

Loading Circuits

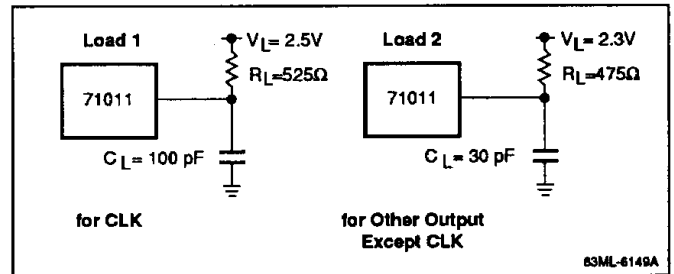

5a