

**USB2.0 Generic Device Controller**

The μPD720122 is USB2.0 Generic Device Controller, which combines the NEC Electronics USB2.0 PHY and End-point Controller. The Controller has certified by USB Implementers Forum. End-point Controller has banked two Bulk End-point and one Interrupt End-point, and selectable three general CPU bus-types, suitable for designing various USB device. The controller has the external local bus, that enables to perform high speed data transferring when CPU is accessing to the controller. These IP Blocks in the controller are based completely on an NEC Electronics ASIC core, so μPD720122 is suitable to design for the prototype system that are intended to design ASIC in the future.

Detailed function descriptions are provided in the following user's manual. Be sure to read the manual before designing.

**μPD720122 User's Manual: S15829E**

**FEATURES**

- Complaint with USB2.0 specification (Maximum data transferring rate: 480 Mbps)
- USB2.0 certified (TestID=40000822)
- High(480Mbps) / Full(12Mbps)- Speed support and switch automatically
- Easy to design NEC Electronics ASIC
- Generic USB2.0 Device Controller
- Two Bulk End-points and One Interrupt End-point
- Performed Data Local Bus independent from CPU bus.  
(Maximum Data Transferring rate: 21 MBps with DMA mode )
- Selectable three CPU Bus Interface

**ORDERING INFORMATION**

Part Number	Package
μPD720122GC-9EU	100-pin plastic TQFP (Fine pitch) (14 × 14)
μPD720122F1-DN2	109-pin plastic FBGA (11 × 11)

The information in this document is subject to change without notice. Before using this document, please confirm that this is the latest version.

Not all products and/or types are available in every country. Please check with an NEC Electronics sales representative for availability and additional information.

BLOCK DIAGRAM

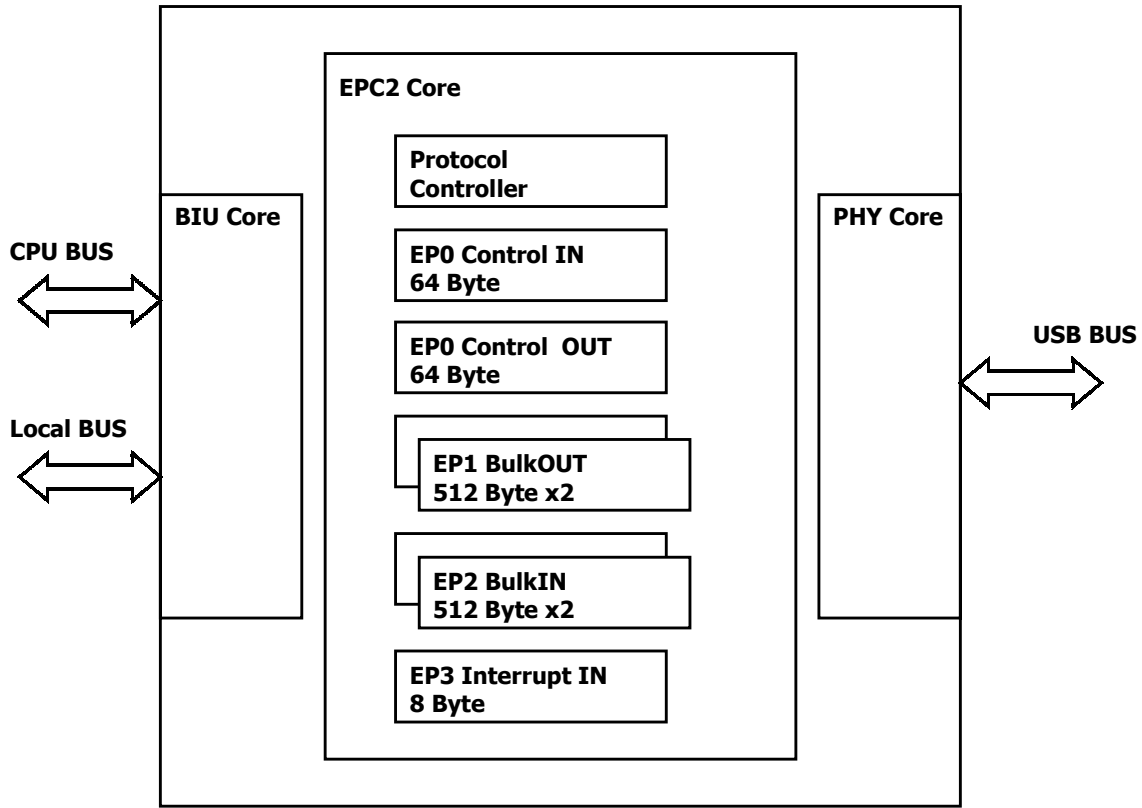

- PHY Core : USB2.0 transceiver with serial interface engine
- EPC2 Core : Endpoint controller
- BIU Core : Bus Interface Unit

PIN CONFIGURATION

- 100-pin plastic TQFP (Fine pitch) (14 × 14)

μPD720122GC-9EU

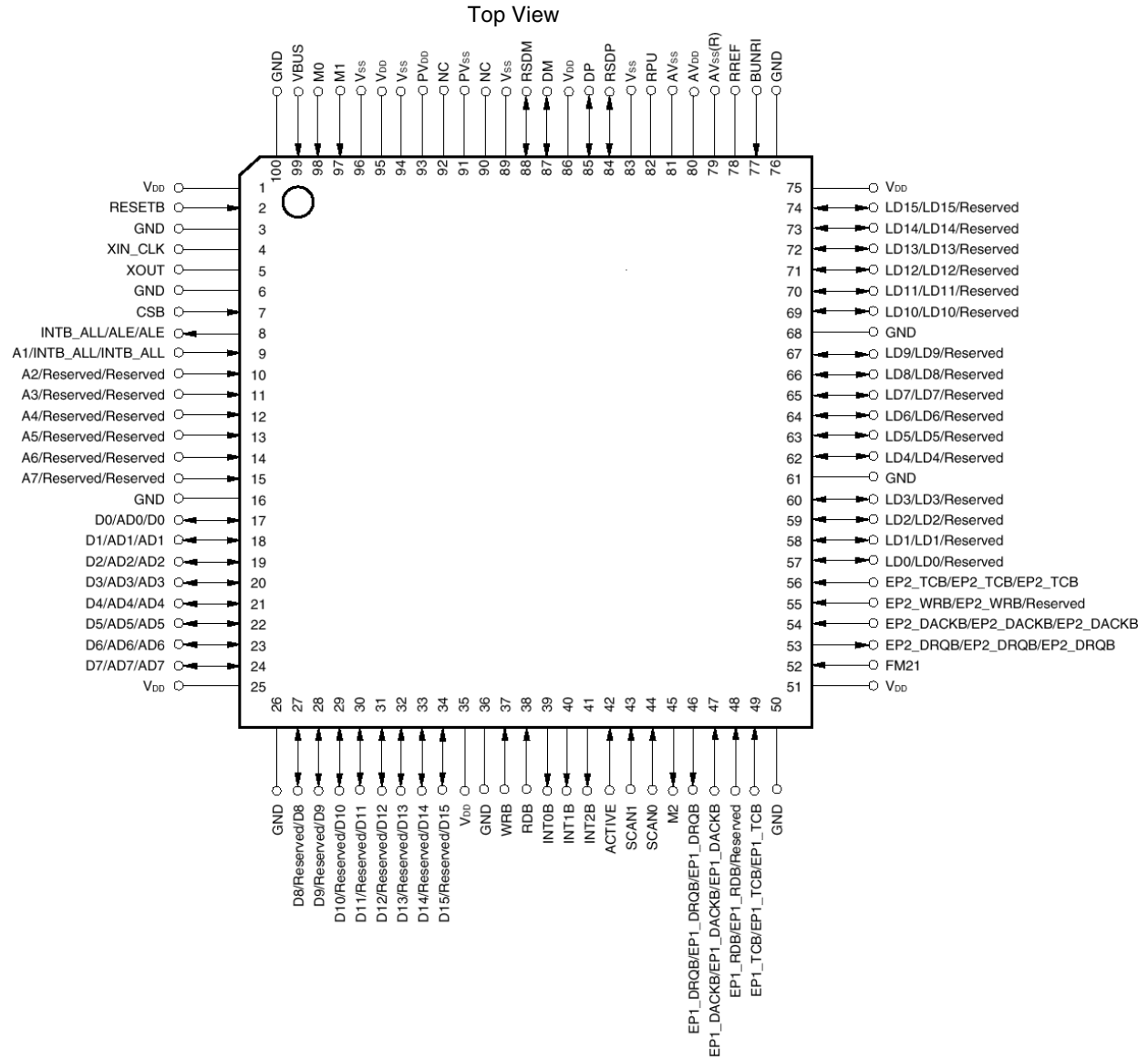

**Remark** The function of the pin is shown with Function 1/Function 2/Function 3 from the left.

μ PD720122GC-9EU

(1/2)

Pin No.	Pin Name Function1	Pin Name Function2	Pin Name Function3	Pin No.	Pin Name Function1	Pin Name Function2	Pin Name Function3
1	V <sub>DD</sub>	V <sub>DD</sub>	V <sub>DD</sub>	26	GND	GND	GND
2	RESETB	RESETB	RESETB	27	D8	Reserved	D8
3	GND	GND	GND	28	D9	Reserved	D9
4	XIN_CLK	XIN_CLK	XIN_CLK	29	D10	Reserved	D10
5	XOUT	XOUT	XOUT	30	D11	Reserved	D11
6	GND	GND	GND	31	D12	Reserved	D12
7	CSB	CSB	CSB	32	D13	Reserved	D13
8	INTB_ALL	ALE	ALE	33	D14	Reserved	D14
9	A1	INTB_ALL	INTB_ALL	34	D15	Reserved	D15
10	A2	Reserved	Reserved	35	V <sub>DD</sub>	V <sub>DD</sub>	V <sub>DD</sub>
11	A3	Reserved	Reserved	36	GND	GND	GND
12	A4	Reserved	Reserved	37	WRB	WRB	WRB
13	A5	Reserved	Reserved	38	RDB	RDB	RDB
14	A6	Reserved	Reserved	39	INT0B	INT0B	INT0B
15	A7	Reserved	Reserved	40	INT1B	INT1B	INT1B
16	GND	GND	GND	41	INT2B	INT2B	INT2B
17	D0	AD0	D0	42	ACTIVE	ACTIVE	ACTIVE
18	D1	AD1	AD1	43	SCAN1	SCAN1	SCAN1
19	D2	AD2	AD2	44	SCAN0	SCAN0	SCAN0
20	D3	AD3	AD3	45	M2	M2	M2
21	D4	AD4	AD4	46	EP1_DRQB	EP1_DRQB	EP1_DRQB
22	D5	AD5	AD5	47	EP1_DACKB	EP1_DACKB	EP1_DACKB
23	D6	AD6	AD6	48	EP1_RDB	EP1_RDB	Reserved
24	D7	AD7	AD7	49	EP1_TCB	EP1_TCB	EP1_TCB
25	V <sub>DD</sub>	V <sub>DD</sub>	V <sub>DD</sub>	50	GND	GND	GND

μ PD720122GC-9EU

(2/2)

Pin No.	Pin Name Fucntion1	Pin Name Function2	Pin Name Function3	Pin No.	Pin Name Fucntion1	Pin Name Function2	Pin Name Function3
51	V <sub>DD</sub>	V <sub>DD</sub>	V <sub>DD</sub>	76	GND	GND	GND
52	FM21	FM21	FM21	77	BUNRI	BUNRI	BUNRI
53	EP2_DRQB	EP2_DRQB	EP2_DRQB	78	RREF	RREF	RREF
54	EP2_DACKB	EP2_DACKB	EP2_DACKB	79	AV <sub>SS</sub> (R)	AV <sub>SS</sub> (R)	AV <sub>SS</sub> (R)
55	EP2_WRB	EP2_WRB	Reserved	80	AV <sub>DD</sub>	AV <sub>DD</sub>	AV <sub>DD</sub>
56	EP2_TCB	EP2_TCB	EP2_TCB	81	AV <sub>SS</sub>	AV <sub>SS</sub>	AV <sub>SS</sub>
57	LD0	LD0	Reserved	82	RPU	RPU	RPU
58	LD1	LD1	Reserved	83	V <sub>SS</sub>	V <sub>SS</sub>	V <sub>SS</sub>
59	LD2	LD2	Reserved	84	RSDP	RSDP	RSDP
60	LD3	LD3	Reserved	85	DP	DP	DP
61	GND	GND	GND	86	V <sub>DD</sub>	V <sub>DD</sub>	V <sub>DD</sub>
62	LD4	LD4	Reserved	87	DM	DM	DM
63	LD5	LD5	Reserved	88	RSDM	RSDM	RSDM
64	LD6	LD6	Reserved	89	V <sub>SS</sub>	V <sub>SS</sub>	V <sub>SS</sub>
65	LD7	LD7	Reserved	90	NC	NC	NC
66	LD8	LD8	Reserved	91	PV <sub>SS</sub>	PV <sub>SS</sub>	PV <sub>SS</sub>
67	LD9	LD9	Reserved	92	NC	NC	NC
68	GND	GND	GND	93	PV <sub>DD</sub>	PV <sub>DD</sub>	PV <sub>DD</sub>
69	LD10	LD10	Reserved	94	V <sub>SS</sub>	V <sub>SS</sub>	V <sub>SS</sub>
70	LD11	LD11	Reserved	95	V <sub>DD</sub>	V <sub>DD</sub>	V <sub>DD</sub>
71	LD12	LD12	Reserved	96	V <sub>SS</sub>	V <sub>SS</sub>	V <sub>SS</sub>
72	LD13	LD13	Reserved	97	M1	M1	M1
73	LD14	LD14	Reserved	98	M0	M0	M0
74	LD15	LD15	Reserved	99	VBUS	VBUS	VBUS
75	V <sub>DD</sub>	V <sub>DD</sub>	V <sub>DD</sub>	100	GND	GND	GND

**Remark** AV<sub>SS</sub> (R) should be used to connect RREF through 1 % precision reference resistor of 9.1 kΩ.

• 109-pin plastic FBGA (11 × 11)

μ PD720122F1-DN2

Bottom View

23 NC	24 BUNRI	25 AV <sub>SS</sub> (R)	26 AV <sub>SS</sub>	27 RSDP	28 V <sub>DD</sub>	29 NC	30 NC	31 V <sub>DD</sub>	32 M1	33 VBUS	34 NC	12	
22 LD15	63 NC	64 RREF	65 AV <sub>DD</sub>	66 GND	67 RSDM	68 PV <sub>SS</sub>	69 GND	70 GND	71 M0	72 NC	35 RESETB	11	
21 LD13	62 LD14	95 GND	96 RPU	97 DP	98 GND	99 DM	100 PV <sub>DD</sub>	101 V <sub>DD</sub>	102 GND	73 GND	36 XIN_CLK	10	
20 LD11	61 LD12	94 V <sub>DD</sub>							103 CSB	74 XOUT	37 GND	9	
19 LD9	60 LD10	93 GND							104 A2	75 INTB_ALL	38 A1	8	
18 LD7	59 LD8	92 LD4							105 A6	76 A5	39 A3	7	
17 GND	58 LD5	91 LD6							106 A4	77 GND	40 A7	6	
16 LD2	57 LD1	90 LD3							107 D1	78 D2	41 D0	5	
15 EP2_TCB	56 EP2_WRB	89 LD0							109 GND	108 V <sub>DD</sub>	79 D4	42 D3	4
14 EP2_DACKB	55 EP2_DRQB	88 GND							87 V <sub>DD</sub>	86 SCAN1	85 WRB	84 INT0B	83 V <sub>DD</sub>
13 FM21	54 NC	53 EP1_RDB	52 EP1_DRQB	51 SCAN0	50 INT2B	49 RDB	48 D14	47 D11	46 D9	45 NC	44 D7	2	
12 NC	11 EP1_TCB	10 EP1_DACKB	9 M2	8 ACTIVE	7 INT1B	6 GND	5 D15	4 D12	3 D10	2 D8	1 NC	1	
M	L	K	J	H	G	F	E	D	C	B	A		

**Remarks** The pin name is showing it with Function1.

As for the pin name of Function2 and Function3, please refer to the table of the next page.

μ PD720122F1-DN2

(1/2)

Pin No.	Pin Name Function1	Pin Name Function2	Pin Name Function3	Pin No.	Pin Name Function1	Pin Name Function2	Pin Name Function3
1	NC	NC	NC	26	AV <sub>SS</sub>	AV <sub>SS</sub>	AV <sub>SS</sub>
2	D8	Reserved	D8	27	RSDP	RSDP	RSDP
3	D10	Reserved	D10	28	V <sub>DD</sub>	V <sub>DD</sub>	V <sub>DD</sub>
4	D12	Reserved	D12	29	NC	NC	NC
5	D15	Reserved	D15	30	NC	NC	NC
6	GND	GND	GND	31	V <sub>DD</sub>	V <sub>DD</sub>	V <sub>DD</sub>
7	INT1B	INT1B	INT1B	32	M1	M1	M1
8	ACTIVE	ACTIVE	ACTIVE	33	VBUS	VBUS	VBUS
9	M2	M2	M2	34	NC	NC	NC
10	EP1_DACKB	EP1_DACKB	EP1_DACKB	35	RESETB	RESETB	RESETB
11	EP1_TCB	EP1_TCB	EP1_TCB	36	XIN_CLK	XIN_CLK	XIN_CLK
12	NC	NC	NC	37	GND	GND	GND
13	FM21	FM21	FM21	38	A1	INTB_ALL	INTB_ALL
14	EP2_DACKB	EP2_DACKB	EP2_DACKB	39	A3	Reserved	Reserved
15	EP2_TCB	EP2_TCB	EP2_TCB	40	A7	Reserved	Reserved
16	LD2	LD2	Reserved	41	D0	AD0	D0
17	GND	GND	GND	42	D3	AD3	AD3
18	LD7	LD7	Reserved	43	D5	AD5	AD5
19	LD9	LD9	Reserved	44	D7	AD7	AD7
20	LD11	LD11	Reserved	45	NC	NC	NC
21	LD13	LD13	Reserved	46	D9	Reserved	D9
22	LD15	LD15	Reserved	47	D11	Reserved	D11
23	NC	NC	NC	48	D14	Reserved	D14
24	BUNRI	BUNRI	BUNRI	49	RDB	RDB	RDB
25	AV <sub>SS</sub> (R)	AV <sub>SS</sub> (R)	AV <sub>SS</sub> (R)	50	INT2B	INT2B	INT2B

**Remark** AV<sub>SS</sub> (R) should be used to connect RREF through 1 % precision reference resistor of 9.1 kΩ.

μ PD720122F1-DN2

(2/2)

Pin No.	Pin Name Function1	Pin Name Function2	Pin Name Function3	Pin No.	Pin Name Function1	Pin Name Function2	Pin Name Function3
51	SCAN0	SCAN0	SCAN0	81	GND	GND	GND
52	EP1_DRQB	EP1_DRQB	EP1_DRQB	82	D13	Reserved	D13
53	EP1_RDB	EP1_RDB	Reserved	83	V <sub>DD</sub>	V <sub>DD</sub>	V <sub>DD</sub>
54	NC	NC	NC	84	INT0B	INT0B	INT0B
55	EP2_DRQB	EP2_DRQB	EP2_DRQB	85	WRB	WRB	WRB
56	EP2_WRB	EP2_WRB	Reserved	86	SCAN1	SCAN1	SCAN1
57	LD1	LD1	Reserved	87	V <sub>DD</sub>	V <sub>DD</sub>	V <sub>DD</sub>
58	LD5	LD5	Reserved	88	GND	GND	GND
59	LD8	LD8	Reserved	89	LD0	LD0	Reserved
60	LD10	LD10	Reserved	90	LD3	LD3	Reserved
61	LD12	LD12	Reserved	91	LD6	LD6	Reserved
62	LD14	LD14	Reserved	92	LD4	LD4	Reserved
63	NC	NC	NC	93	GND	GND	GND
64	RREF	RREF	RREF	94	V <sub>DD</sub>	V <sub>DD</sub>	V <sub>DD</sub>
65	AV <sub>DD</sub>	AV <sub>DD</sub>	AV <sub>DD</sub>	95	GND	GND	GND
66	GND	GND	GND	96	RPU	RPU	RPU
67	RSDM	RSDM	RSDM	97	DP	DP	DP
68	PV <sub>SS</sub>	PV <sub>SS</sub>	PV <sub>SS</sub>	98	GND	GND	GND
69	GND	GND	GND	99	DM	DM	DM
70	GND	GND	GND	100	PV <sub>DD</sub>	PV <sub>DD</sub>	PV <sub>DD</sub>
71	M0	M0	M0	101	V <sub>DD</sub>	V <sub>DD</sub>	V <sub>DD</sub>
72	NC	NC	NC	102	GND	GND	GND
73	GND	GND	GND	103	CSB	CSB	CSB
74	XOUT	XOUT	XOUT	104	A2	Reserved	Reserved
75	INTB_ALL	ALE	ALE	105	A6	Reserved	Reserved
76	A5	Reserved	Reserved	106	A4	Reserved	Reserved
77	GND	GND	GND	107	D1	AD1	AD1
78	D2	AD2	AD2	108	V <sub>DD</sub>	V <sub>DD</sub>	V <sub>DD</sub>
79	D4	AD4	AD4	109	GND	GND	GND
80	D6	AD6	AD6	-	-	-	-



1. PIN INFORMATION

(1/2)

Pin Name	I/O	Buffer Type	Active Level	Function
RESETB	I	5 V tolerant Input Schmitt	Low	Asynchronous reset signaling
XIN_CLK	I	3.3 V Input		System clock input or oscillator In
XOUT	O	3.3 V Output		Oscillator out
CSB	I	5 V tolerant Input	Low	Chip select signal
INTB_ALL	O	5 V tolerant Output	Low	Interrupt request signal
ALE	I	5 V tolerant Input	High	Address strobe signal (Function2/3)
A(7:1)	I	5 V tolerant Input		Address input (Function1)
D(15:0)	I/O	5 V tolerant I/O		Data bus (I/O) (Function1)
AD(7:0)	I/O	5 V tolerant I/O		Address/data multiplexed bus (I/O) (Function2)
D0	I/O	5 V tolerant I/O		Data bus (I/O) (Function3)
AD(7:1)	I/O	5 V tolerant I/O		Address/data multiplexed bus (I/O) (Function3)
D(15:8)	I/O	5 V tolerant I/O		Data bus (I/O) (Function3)
WRB	I	5 V tolerant Input	Low	Write command input
RDB	I	5 V tolerant Input	Low	Read command input
INT0B	O	5 V tolerant Output	Low	Interrupt request (INT Status 0)
INT1B	O	5 V tolerant Output	Low	Interrupt request (INT Status 1)
INT2B	O	5 V tolerant Output	Low	Interrupt request (INT Status 2)
ACTIVE	I	5 V tolerant Input		DMA-related pins active level select(Function2/3)
SCAN(1:0)	I	3.3 V Input 50 kΩ Pull Down		Chip test pin.
M2	O	5 V tolerant Output		Status output pin
EP1_DRQB	O	5 V tolerant Output	Low	DMA transfer request output pin of EP1
EP1_DACKB	I	5 V tolerant Input	Low	DMA transfer enable input pin of EP1
EP1_RDB	I	5 V tolerant Input	Low	DMA Read command input pin of EP1
EP1_TCB	I	5 V tolerant Input	Low	DMA terminal count input pin of EP1
FM21	I	3.3 V Input		NEC Electronics test pin
EP2_DRQB	O	5 V tolerant Output	Low	DMA transfer request output pin of EP2
EP2_DACKB	I	5 V tolerant Input	Low	DMA transfer enable input pin of EP2
EP2_WRB	I	5 V tolerant Input	Low	DMA Write command input pin of EP2
EP2_TCB	I	5 V tolerant Input	Low	DMA terminal count input pin of EP2
LD(15:0)	I/O	5 V tolerant I/O		Data bus (I/O) pin for external local bus
BUNRI	I	5V torelant Input		NEC Electronics test pin
RREF	A	Analog		Reference resistor
RPU	A	USB pull-up control		USB's 1.5 kΩ pull-up resistor control
RSDP	O	USB full speed D+ O		USB's full speed D+ signal
DP	I/O	USB high speed D+ I/O		USB's high speed D+ signal
DM	I/O	USB high speed D- I/O		USB's high speed D- signal

(2/2)

Pin Name	I/O	Buffer Type	Active Level	Function
RSDM	O	USB full speed D- O		USB's full speed D- signal
M(1:0)	I	5 V tolerant Input		Function mode setting
VBUS	I	5 V tolerant Input <sup>Note</sup>		VBUS monitoring
AV <sub>DD</sub> , PV <sub>DD</sub>				3.3 V <sub>DD</sub> for Analog circuit
V <sub>DD</sub>				3.3 V <sub>DD</sub>
AV <sub>SS</sub> , PV <sub>SS</sub>				V <sub>SS</sub> for Analog circuit
V <sub>SS</sub> , GND				V <sub>SS</sub>
NC				Not connect
Reserved				Not used

**Note** VBUS pin may be used to monitor for VBUS line even if V<sub>DD</sub>, AV<sub>DD</sub>, and PV<sub>DD</sub> are shut off. System must ensure that the input voltage level for VBUS pin is less than 3.0 V due to the absolute maximum rating is not exceeded.

**Remark** “5 V tolerant“ means that the buffer is 3.3 V buffer with 5 V tolerant circuit.

The operation mode of the BIU can be set by external pins, as shown below. Fix external pins (M1 and M0) when using them.

Pin		BIU Operation Mode	Outline
M1	M0		
0	0	16-bit mode (Function 1)	A 16-bit CPU bus and an external local bus dedicated to data transfer for bulk IN/OUT can be used in this mode. The internal register length is 16 bits.
0	1	8-bit mode (Function 2)	Multiplexed bus mode of 8-bit address bus and 8-bit data bus. The register length is 8 bits only in this mode (registers can only be accessed in byte units). Therefore, the address space in this mode differs from that in the other modes. The active levels of some external local bus control pins can be changed by the Active pin.
1	0	16-bit mix mode (Function 3)	Multiplexed bus mode of 8-bit address bus and 16-bit data bus. The internal register length is 16 bits. The active levels of some external local bus control pins can be changed by the Active pin.
1	1	Setting prohibited (Function 4)	Setting prohibited

## 2. ELECTRICAL SPECIFICATIONS

### 2.1 Buffer List

- 3.3 V oscillator interface  
XIN,XOUT
- 3.3 V input buffer  
FM21,SCAN(1:0)
- 5V torelant input buffer  
RESETB,CSB,A(7:0),WRB,RDB,ACTIVE,EP1\_DACKB,EP1\_RDB,EP1\_TCB,EP2\_DACKB,EP2\_WRB,  
EP2\_TCB,BUNRI,M0,M1,VBUS,ALE
- 5V torelant output buffer  
INTB\_ALL,INT0B,INT1B,INT2B,M2,EP1\_DRQB,EP2\_DRQB
- 5V torelant I/O buffer  
D(15:0),LD(15:0),AD(7:0),D0,AD(7:1),D(15:8)
- USB interface  
DP,DM,RSDP,RSDM,RREF,RPU

### 2.2 Terminology

#### Terms Used in Absolute Maximum Ratings

Parameter	Symbol	Meaning
Power supply voltage	V <sub>DD</sub>	Indicates voltage range within which damage or reduced reliability will not result when power is applied to a V <sub>DD</sub> pin.
Input voltage	V <sub>i</sub>	Indicates voltage range within which damage or reduced reliability will not result when power is applied to an input pin.
Output voltage	V <sub>o</sub>	Indicates voltage range within which damage or reduced reliability will not result when power is applied to an output pin.
Output current	I <sub>o</sub>	Indicates absolute tolerance value for DC current to prevent damage or reduced reliability when a current flows out of or into an output pin.
Operating temperature	T <sub>A</sub>	Indicates the ambient temperature range for normal logic operations.
Storage temperature	T <sub>stg</sub>	Indicates the element temperature range within which damage or reduced reliability will not result while no voltage or current are applied to the device.

**Terms Used in Recommended Operating Range**

Parameter	Symbol	Meaning
Power supply voltage	V <sub>DD</sub>	Indicates the voltage range for normal logic operations occur when V <sub>SS</sub> = 0 V.
High-level input voltage	V <sub>IH</sub>	Indicates the voltage, which is applied to the input pins of the device, is the voltage indicates that the high level states for normal operation of the input buffer. * If a voltage that is equal to or greater than the "Min." value is applied, the input voltage is guaranteed as high level voltage.
Low-level input voltage	V <sub>IL</sub>	Indicates the voltage, which is applied to the input pins of the device, is the voltage indicates that the low level states for normal operation of the input buffer. * If a voltage that is equal to or lesser than the "Max." value is applied, the input voltage is guaranteed as low level voltage.
Hysteresys voltage	V <sub>H</sub>	Indicates the differential between the positive trigger voltage and the negative trigger voltage.
Input rise time	t <sub>ri</sub>	Indicates allowable input rise time to input pins. Input rise time is transition time from 0.1 × V <sub>DD</sub> to 0.9 × V <sub>DD</sub> .
Input fall time	t <sub>fi</sub>	Indicates allowable input fall time to input pins. Input fall time is transition time from 0.9 × V <sub>DD</sub> to 0.1 × V <sub>DD</sub> .

**Terms Used in DC Characteristics**

Parameter	Symbol	Meaning
Off-state output leakage current	I <sub>oz</sub>	Indicates the current that flows from the power supply pins when the rated power supply voltage is applied when a 3-state output has high impedance.
Output short circuit current	I <sub>os</sub>	Indicates the current that flows when the output pin is shorted (to GND pins) when output is at high-level.
Input leakage current	I <sub>I</sub>	Indicates the current that flows when the input voltage is supplied to the input pin.
Low-level output current	I <sub>oL</sub>	Indicates the current that flows to the output pins when the rated low-level output voltage is being applied.
High-level output current	I <sub>oH</sub>	Indicates the current that flows from the output pins when the rated high-level output voltage is being applied.

2.3 Absolute Maximum Ratings

Parameter	Symbol	Conditions	Ratings	Unit
Voltage	$V_{DD}$		-0.5 to +4.6	V
I/O voltage	$V_i/V_o$			
	<b>Note 1</b>	$V_i/V_o < V_{DD}+3.0\text{ V}$	-0.5 to +6.6	V
	<b>Note 2</b>	$V_i/V_o < V_{DD}+0.3\text{ V}$	-0.5 to +4.6	V
Output current	$I_o$			
	<b>Note 3</b>	$I_{oL} = 6\text{ mA}$	6	mA
Operating ambient temperature	$T_A$		0 to +70	°C
Storage temperature	$T_{stg}$		-65 to +150	°C

- Notes**
1. 5 V torelant input buffer, output buffer, I/O buffer
  2. 3.3 V input buffer, 3.3 V oscillator interface
  3. 5 V torelant output buffer, I/O buffer(OUT)

**Caution** Product quality may suffer if the absolute maximum rating is exceeded even momentarily for any parameter. That is, the absolute maximum ratings are rated values at which the product is on the verge of suffering physical damage, and therefore the product must be used under conditions that ensure that the absolute maximum ratings are not exceeded.

2.4 Recommended Operating Range

Parameter	Symbol	Conditions	Min.	Typ.	Max.	Unit
Power supply voltage	$V_{DD}$	3.3 V Power	3.0	3.3	3.6	V
Negative trigger voltage	$V_N$		0.6		1.8	V
Positive trigger voltage	$V_P$		1.2		2.4	V
Hysteresis voltage	$V_H$		0.3		1.5	V
Input voltage, low	$V_{IL}$		0		0.8	V
Input voltage, high	$V_{IH}$	3.3 V input buffer	2.0		$V_{DD}$	V
		5V torelant input buffer, I/O buffer	2.0		5.5	V
Rise/fall time	$t_r/t_f$		0		200	ns

2.5 DC Characteristics

The DC characteristics are classified into those of the USB interface and those of the BIU block.

2.5.1 DC characteristics of USB interface

Parameter	Symbol	Conditions	Min.	Max.	Unit
Serial resistor between DP (DM) and RSDP (RSDM)	R <sub>S</sub>		35.64	36.36	Ω
Driver output resistance (also serves as high-speed termination)	Z <sub>HSDRV</sub>	Includes R <sub>S</sub> resistor	40.5	49.5	Ω
Bus pull-up resistor on upstream facing port	R <sub>PU</sub>		1.425	1.575	Ω
Termination voltage for upstream facing port pull-up (full-speed)	V <sub>TERM</sub>		3.0	3.6	V
<b>Input levels for full-speed:</b>					
High-level input voltage (driven)	V <sub>IH</sub>		2.0		V
High-level input voltage (floating)	V <sub>IHZ</sub>		2.7	3.6	
Low-level input voltage	V <sub>IL</sub>			0.8	V
Differential input sensitivity	V <sub>DI</sub>	(D+) – (D-)	0.2		V
Differential common mode range	V <sub>CM</sub>	Includes V <sub>DI</sub> range	0.8	2.5	V
<b>Output levels for full-speed:</b>					
High-level output voltage	V <sub>OH</sub>	R <sub>L</sub> of 14.25 kΩ to V <sub>SS</sub>	2.8	3.6	V
Low-level output voltage	V <sub>OL</sub>	R <sub>L</sub> of 1.425 kΩ to 3.6 V	0.0	0.3	V
SE1	V <sub>OSE1</sub>		0.8		V
Output signal crossover voltage	V <sub>CRS</sub>		1.3	2.0	V
<b>Input levels for high-speed:</b>					
High-speed squelch detection threshold (differential signal amplitude)	V <sub>HSSQ</sub>		100	150	mV
High-speed disconnect detection threshold (differential signal amplitude)	V <sub>HSDSC</sub>		525	625	mV
High-speed data signaling common mode voltage range (guideline for receiver)	V <sub>HSCM</sub>		-50	500	mV
High-speed differential input signaling level	See Figure 2-4				
<b>Output levels for high-speed:</b>					
High-speed idle level	V <sub>HSOI</sub>		-10.0	10	mV
High-speed data signaling high	V <sub>HSOH</sub>		360	440	mV
High-speed data signaling low	V <sub>HSOL</sub>		-10.0	10	mV
Chirp J level (different voltage)	V <sub>CHIRPJ</sub>		700	1100	mV
Chirp K level (different voltage)	V <sub>CHIRPK</sub>		-900	-500	mV

Figure 2-1. Differential Input Sensitivity Range for Low-/Full-Speed

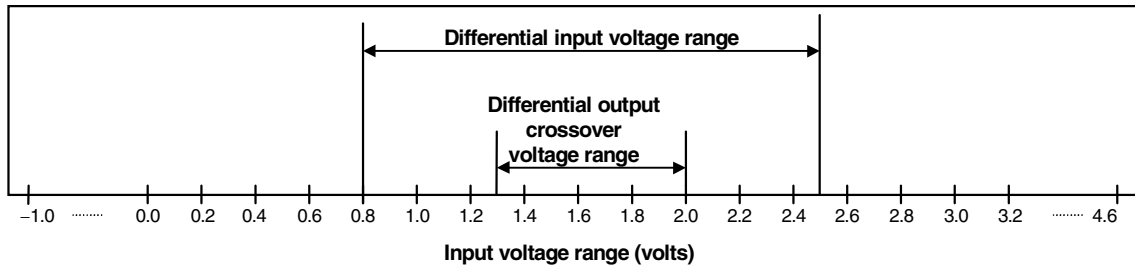

Figure 2-2. Full-Speed Buffer Voh/Ioh Characteristics for High-Speed Capable Transceiver

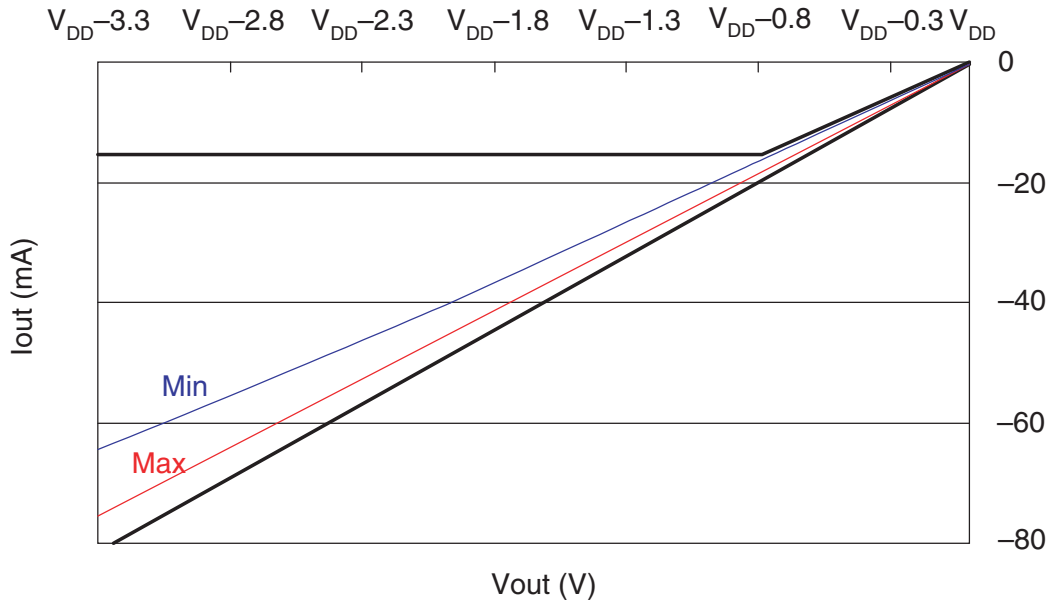

Figure 2-3. Full-Speed Buffer Vol/Iol Characteristics for High-Speed Capable Transceiver

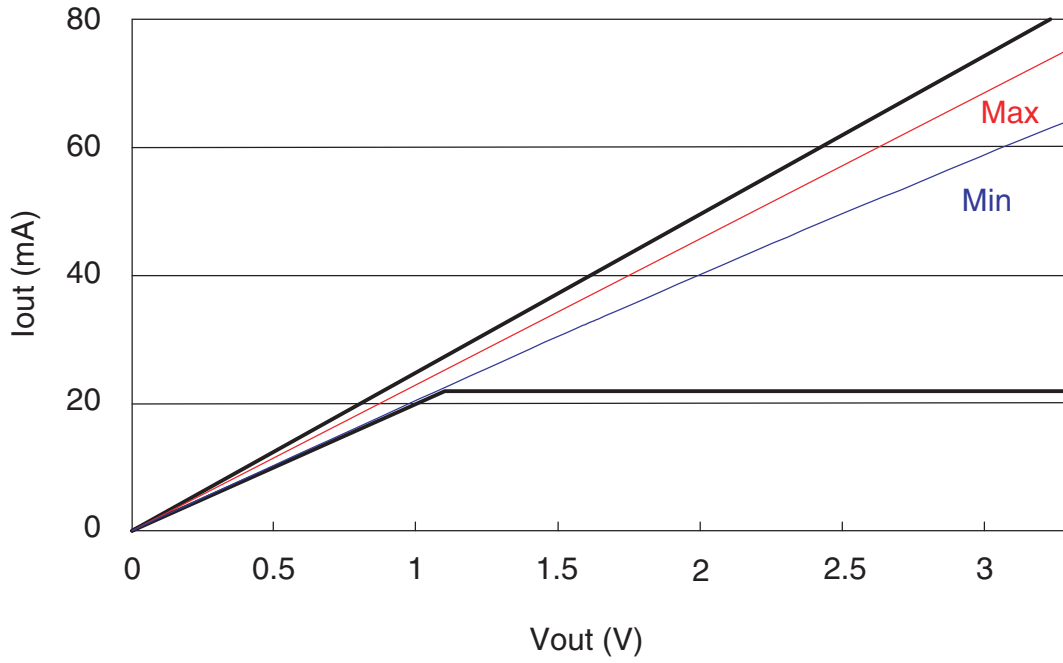

Figure 2-4. Receiver Sensitivity for Transceiver at D+/D-

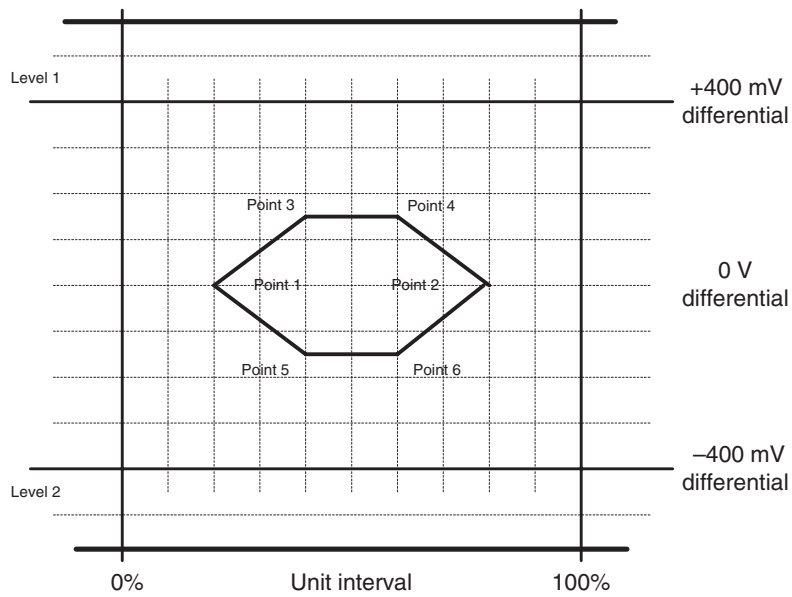
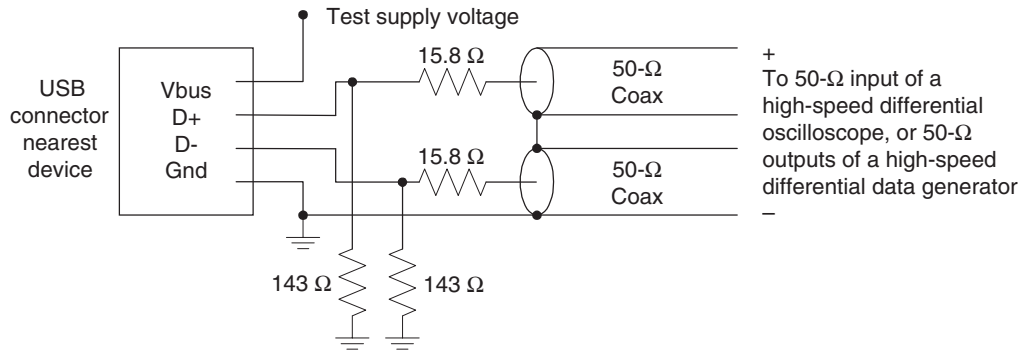



Figure 2-5. Receiver Measurement Fixtures



2.5.2 DC characteristics of BIU

Parameter	Symbol	Conditions	Min.	Typ.	Max.	Unit
Off-state output current	$I_{OZ}$	$V_O = V_{DD}$ or GND			±10	μA
Output short current	$I_{OS}$				-250	mA
Input leakage current	$I_I$	$V_I = V_{DD}$ or GND		±10 <sup>-5</sup>		μA
Output current, low	$I_{OL}$	$V_{OL} = 0.4 V$ <sup>Note</sup>	6			mA
Output current, high	$I_{OH}$	$V_{OH} = 2.4 V$	-2			mA
Output voltage, low	$V_{OL}$	$I_{OL} = 0 mA$			0.1	V
Output voltage, high	$V_{OH}$	$I_{OH} = 0 mA$	$V_{DD}-0.2$			V

**Note** 5V-Tolerant Output

**2.5.3 Pin capacitance**

Parameter	Symbol	Conditions	Min.	Typ.	Max.	Unit
Input capacitance	C <sub>IN</sub>		4.5		6.5	pF
Output/bidirectional capacitance	C <sub>OUT</sub>		8.5		11	pF

**Remark** These are just estimated values.

**2.5.4 Power consumption**

Parameter	Symbol	Conditions	Min.	Typ.	Max.	Unit	
Power consumption	P <sub>H</sub>	HS mode	V <sub>DD</sub>		195	273	mA
			AV <sub>DD</sub>		12	17	mA
	P <sub>F</sub>	FS mode	V <sub>DD</sub>		120	168	mA
			AV <sub>DD</sub>		12	17	mA
	P <sub>S1</sub>	Suspend mode 1 <sup>Note 1</sup>	V <sub>DD</sub>		1.5	2.2	mA
			AV <sub>DD</sub>		0.1	0.2	μA
	P <sub>S2</sub>	Suspend mode 2 <sup>Note 2</sup>	V <sub>DD</sub>		370	520	μA
			AV <sub>DD</sub>		0.1	0.2	μA

- Notes**
1. SND PHY Reg. SPND bit = 1
  2. SND PHY Reg. SPND bit = 1  
 GPR Reg. CONNECTB bit = 0  
 GPR Reg. PUE bit = 0  
 BIU Control 0 Reg. OSC\_DISCONB bit = 1

2.6 AC Characteristics (T<sub>A</sub> = 0 to +70°C, V<sub>DD</sub> = 3.3 V ±10%)

The AC characteristics are classified into those of the USB interface block and those of the BIU.

2.6.1 Overall AC characteristics and those of BIU

(1) Clock

Parameter	Symbol	Condition	Min.	Typ.	Max.	Unit
Clock frequency	f <sub>CLK</sub>	X'tal	-500ppm	30	+500ppm	MHz
		Oscillator block	-500ppm	30	+500ppm	MHz
Clock Duty cycle	T <sub>DUTY</sub>		40	50	60	%

- Remarks 1.** Recommended accuracy of clock frequency is ±100ppm.  
**2.** Required accuracy of X'tal or Oscillator block is including initial frequency accuracy, the spread of X'tal capacity or loading, supply voltage, temperature, and aging etc.

(2) Reset

Symbol	Specification	Min.	Typ.	Max.	Unit
TR	Reset width	2			μs

HW reset timing

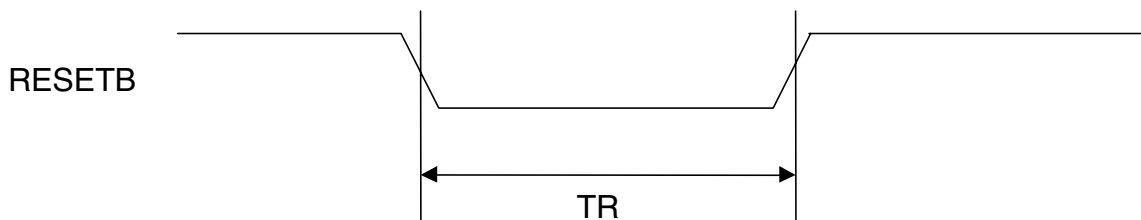

2.6.2 AC characteristics of BIU block with Function 1 selected

(1) CPU BUS read operation

Symbol	Parameter	Min.	Typ.	Max.	Unit
T1	Read cycle time	91		∞	ns
T2	Address setup time (RDB↓)	5		∞	ns
T3	Chip select setup time (RDB↓)	5		∞	ns
T4	Buffer direction change time (RDB↓)	–		14	ns
T5	Output data delay time (RDB↓)	–		57	ns
T6	Read command width	57		∞	ns
T7	Chip select hold time (RDB↑)	5		∞	ns
T8	Address hold time (RDB↑)	5		∞	ns
T9	RDB inactive time	34		∞	ns
T10	Output data hold time (RDB↑)	4		–	ns

**Remark** It is assumed that the external pin capacitance is 15 pF (data bus = 50 pF).

CPU bus read timing

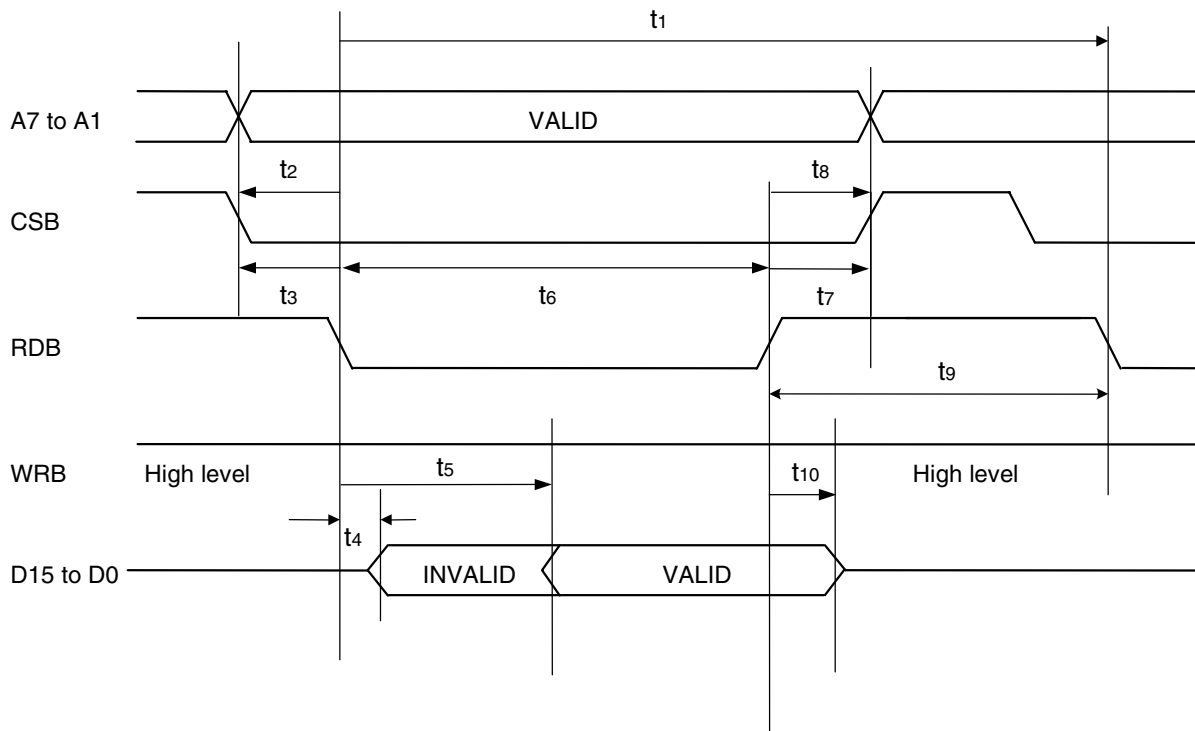

(2) CPU bus write operation

Symbol	Parameter	Min.	Typ.	Max.	Unit
T11	Write cycle time	68		∞	ns
T12	Address setup time (WRB↓)	5		∞	ns
T13	Chip select setup time (WRB↓)	5		∞	ns
T14	Write command width	34		∞	ns
T15	Address hold time (WRB↑)	5		∞	ns
T16	Chip select hold time (WRB↑)	5		∞	ns
T17	WRB inactive time	34		∞	ns
T18	Input data setup time	10		∞	ns
T19	Input data hold time	0		∞	ns

**Remark** It is assumed that the external pin capacitance is 15 pF (data bus = 50 pF).

CPU bus write timing

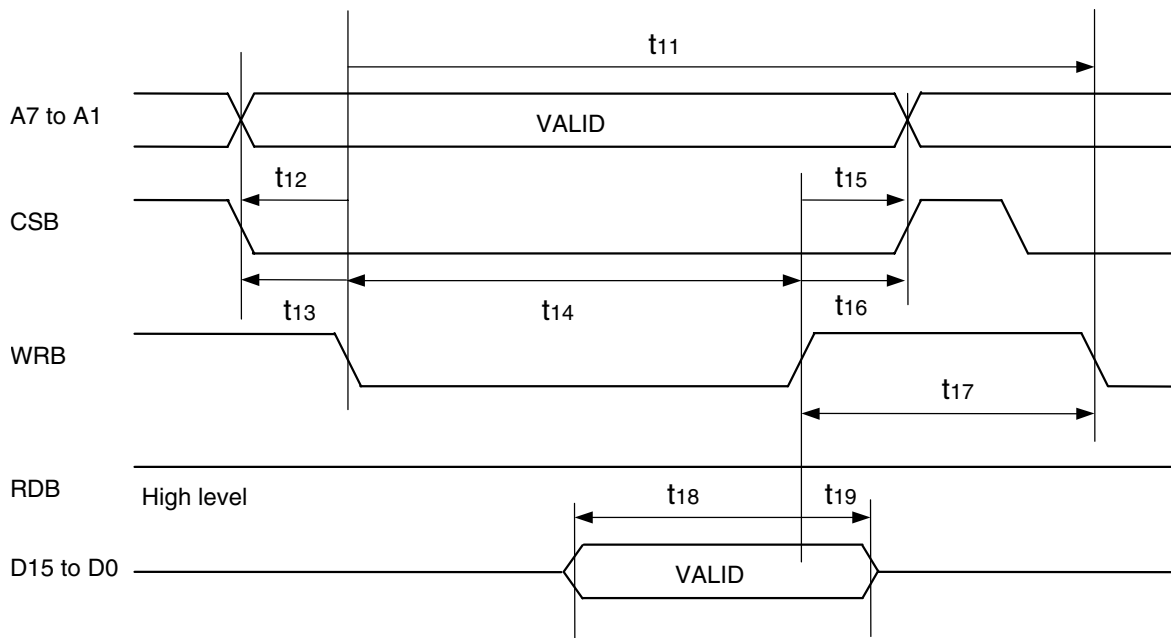

**(3) CPU BUS RDB vs. WRB timing**

Symbol	Parameter	Min.	Typ.	Max.	Unit
T20	WRB vs. RDB inactive time	34		∞	ns

**Remark** It is assumed that the external pin capacitance is 15 pF (data bus = 50 pF).

**CPU bus read vs. write change timing**

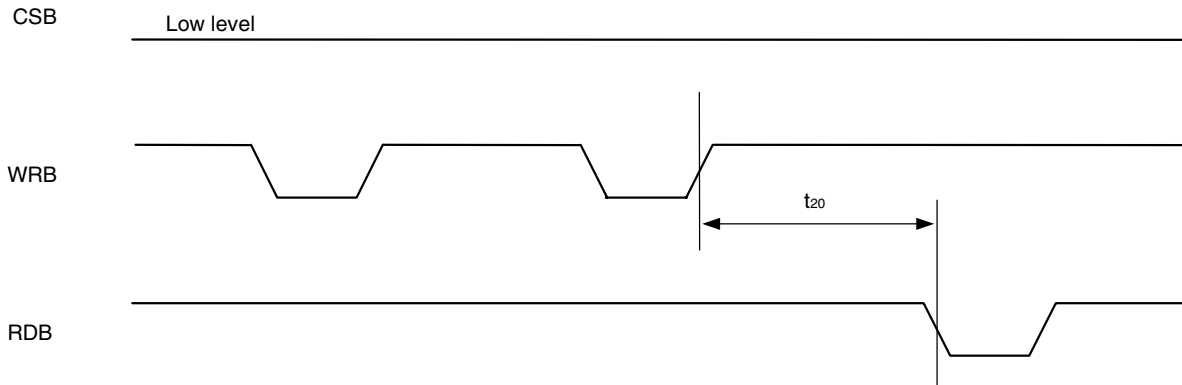

(4) CPU bus DMA transfer

(a) CPU bus DMA single mode read transfer timing

Symbol	Parameter	Min.	Typ.	Max.	Unit
T21	DMA request acknowledge setup time (RDB↓)	0		∞	ns
T22	DMA request off time (EP1_DACKB↓)	–		54	ns
T23	DMA single mode read transfer cycle time	91		∞	ns
T24	Read command width	57		∞	ns
T25	Read command inactive time	34		∞	ns
T26	Read data delay time (RDB↓)	–		57	ns
T27	Buffer direction change time (RDB↓)	–		14	ns
T28	Read data hold time (RDB↑)	4		–	ns
T29	EP1_TCB setup time (RDB↓)	0		<b>Note</b>	ns
T30	EP1_TCB hold time (RDB↓)	17		∞	ns
T31	EP1_STOPB delay time (RDB↓)	–		15	ns
T32	EP1_STOPB OFF delay time (RDB↑)	3		–	ns
T33	DMA request acknowledge hold time (RDB↑)	0		∞	ns
T34	Undefined	–		–	ns

**Note** Can be input after previous RDB↑.

**Remark** It is assumed that the external pin capacitance is 15 pF (data bus = 50 pF).

(Overall)

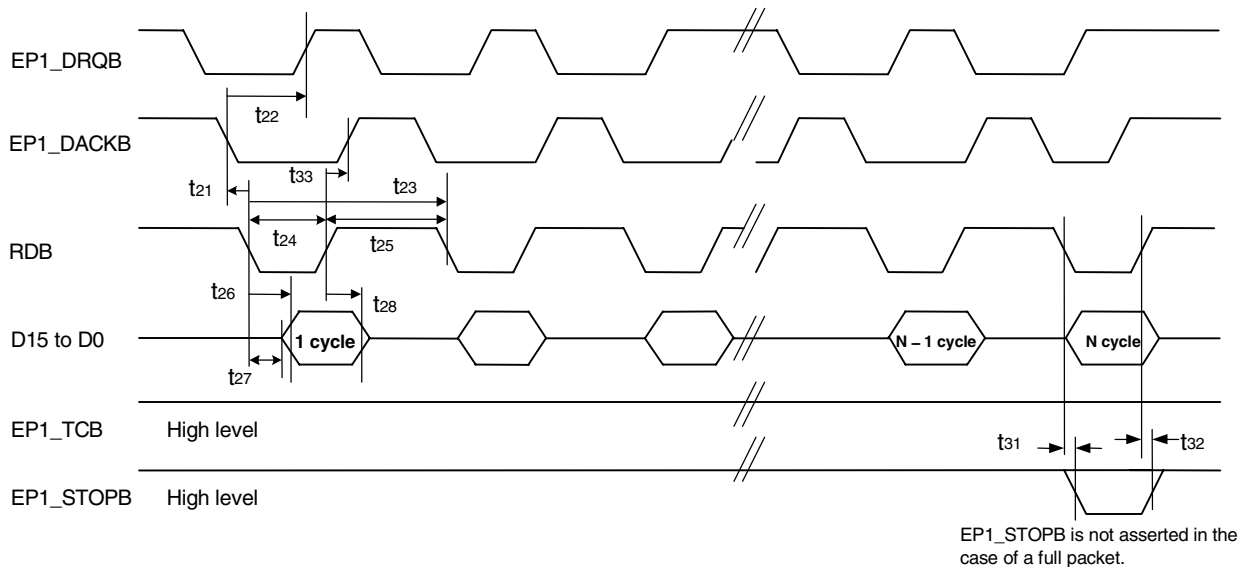



**(Start timing)**

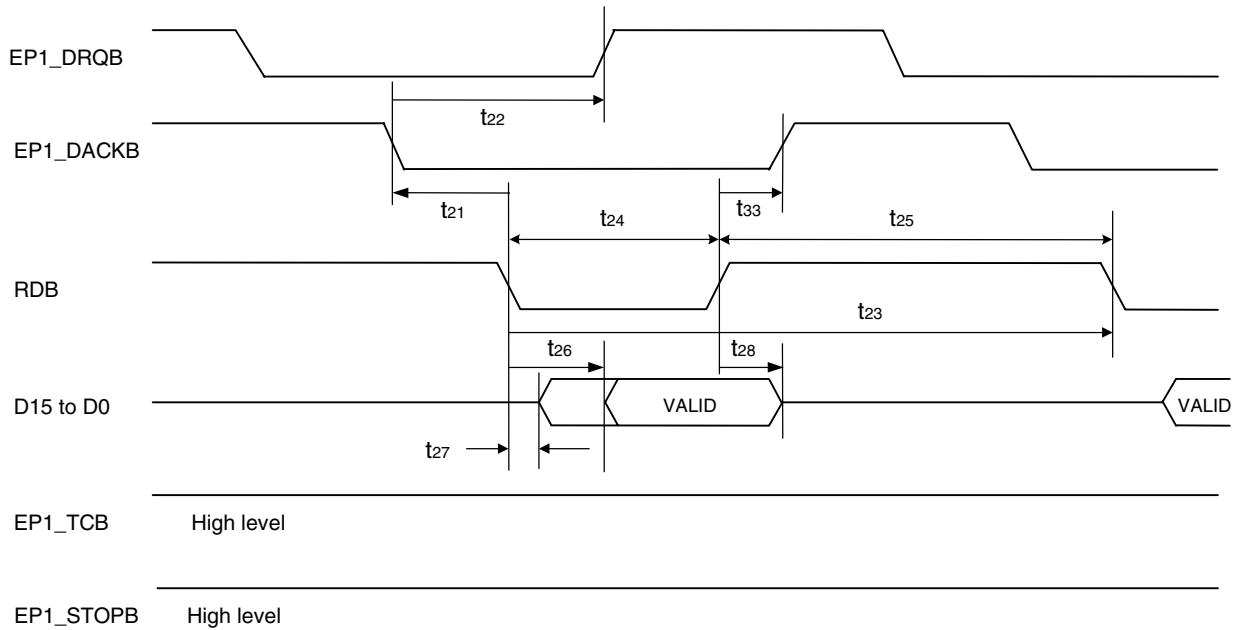

**(End timing)**

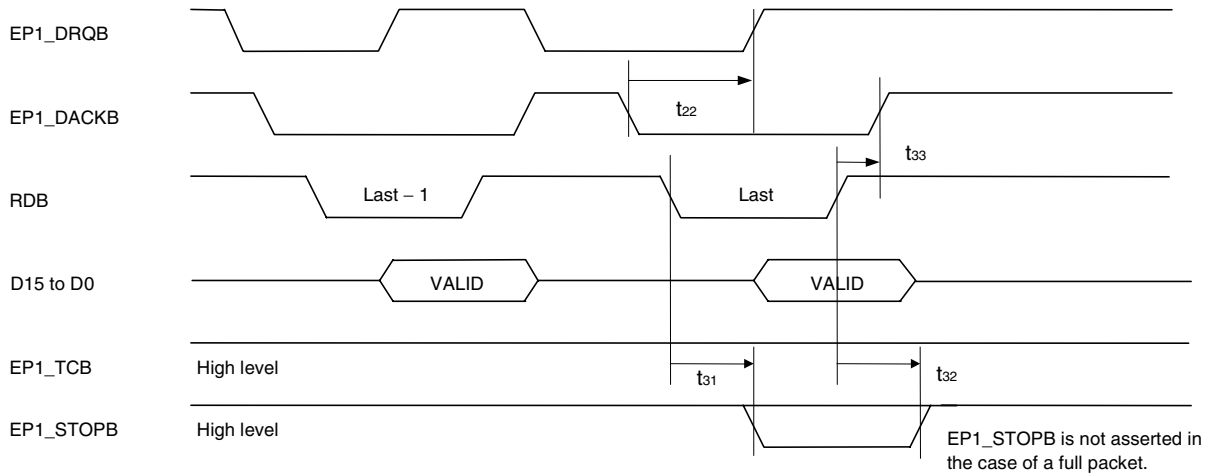

(TCB timing)

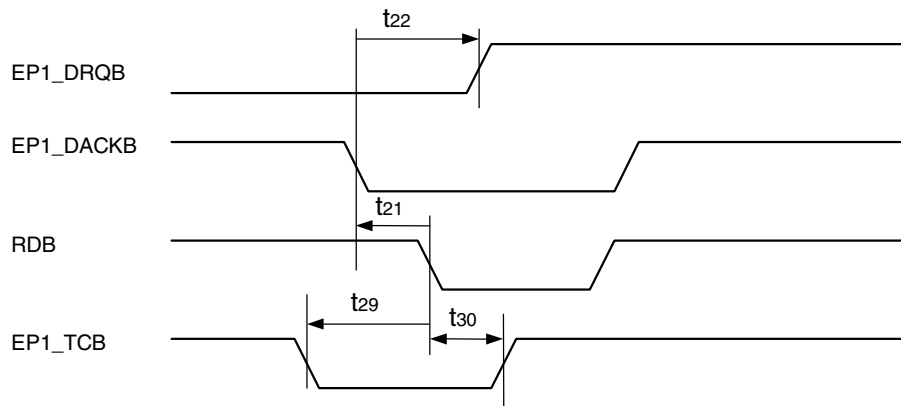

(b) CPU bus DMA single mode write transfer

Symbol	Parameter	Min.	Typ.	Max.	Unit
T35	DMA request acknowledge setup time (WRB↓)	0		∞	ns
T36	DMA request off time (EP2_DACKB↓)	–		54	ns
T37	DMA single mode write transfer cycle time	88		∞	ns
T38	Write command width	54		∞	ns
T39	Write command inactive time	34		∞	ns
T40	Write data setup time (WRB↑)	10		∞	ns
T41	Write data hold time (WRB↑)	0		∞	ns
T42	EP2_TCB setup time (WRB↓)	0		<b>Note</b>	ns
T43	EP2_TCB hold time (WRB↓)	17		∞	ns
T44	DMA request acknowledge hold time (WRB↑)	0		∞	ns

**Note** Can be input after immediately previous WRB↑.

**Remark** It is assumed that the external pin capacitance is 15 pF (data bus = 50 pF).

(Overall)

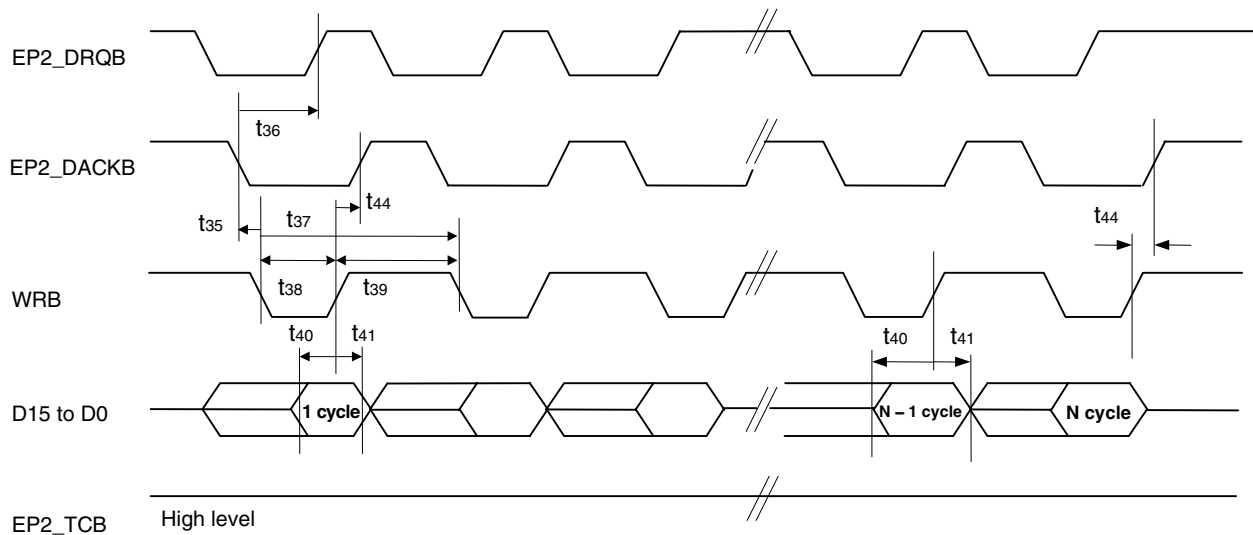

(Start timing)

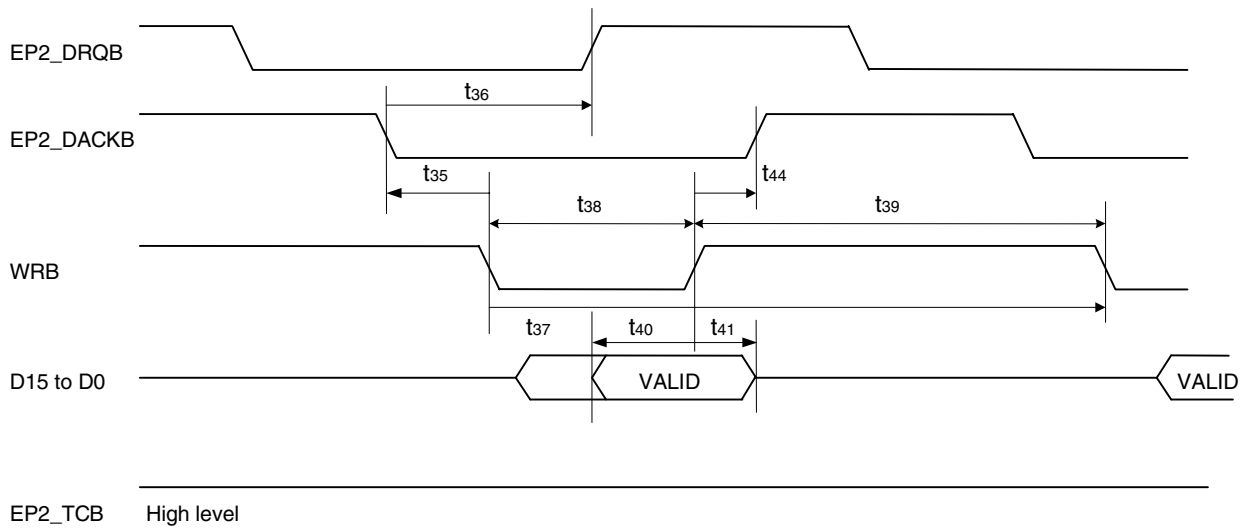

(End timing)

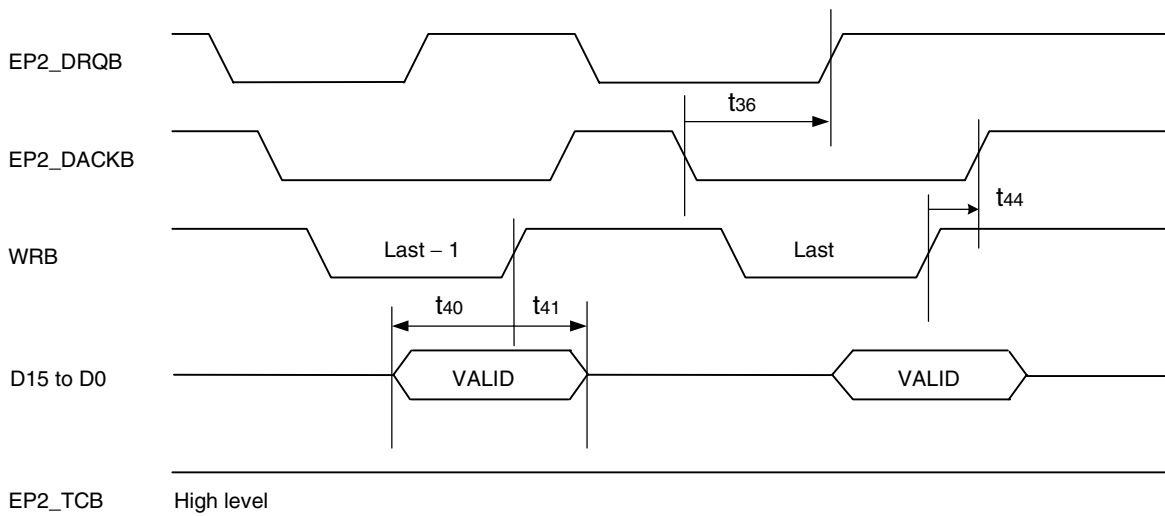

(TCB timing)

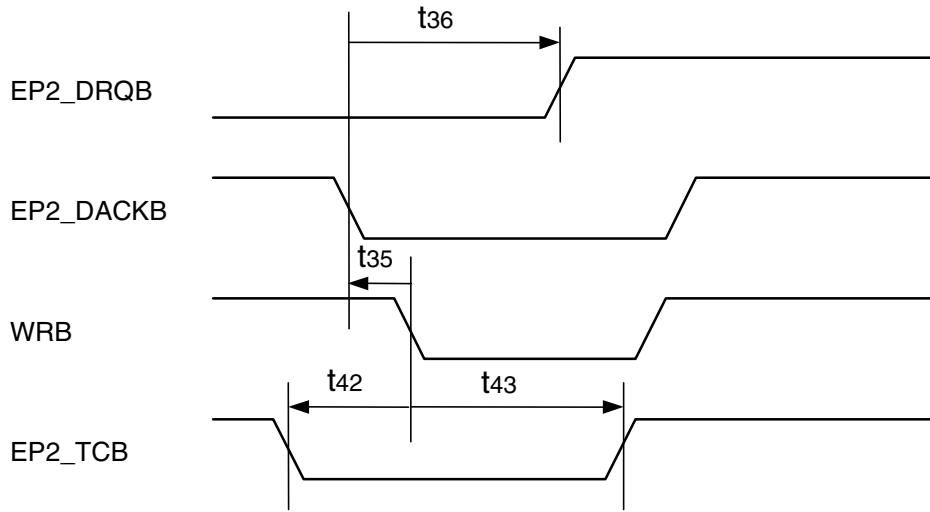

(c) CPU bus DMA demand read transfer timing

Symbol	Parameter	Min.	Typ.	Max.	Unit
T45	DMA request acknowledge setup time (RDB↓)	0		∞	ns
T46	DMA demand mode read transfer cycle time	91		∞	ns
T47	Read command width	57		∞	ns
T48	Read command inactive time	34		∞	ns
T49	Read data delay time (RDB↓)	–		57	ns
T50	Buffer direction change time (RDB↓)	–		14	ns
T51	Read data hold time (RDB↑)	4		–	ns
T52	EP1_TCB setup time (RDB↓)	0		<b>Note</b>	ns
T53	EP1_TCB hold time (RDB↓)	17		∞	ns
T54	EP1_STOPB delay time (RDB↓)	–		15	ns
T55	EP1_STOPB delay time (RDB↑)	3		–	ns
T56	DMA request off time (RDB↑)	–		59	ns
T57	DMA request acknowledge hold time (RDB↑)	0		∞	ns
T69	DMA request off time (EP1_DACKB↓)	–		38	ns
T71	DMA request off time (EP1_DACKB↓) 1 cycle transfer	–		38	ns
T72	DMA request on time (EP1_DACKB↑)	–		88	ns
T74	DMA request off time (RDB↓)	–		60	ns

**Note** Can be input after immediately previous RDB↑.

**Remark** It is assumed that the external pin capacitance is 15 pF (data bus = 50 pF).

(Overall)

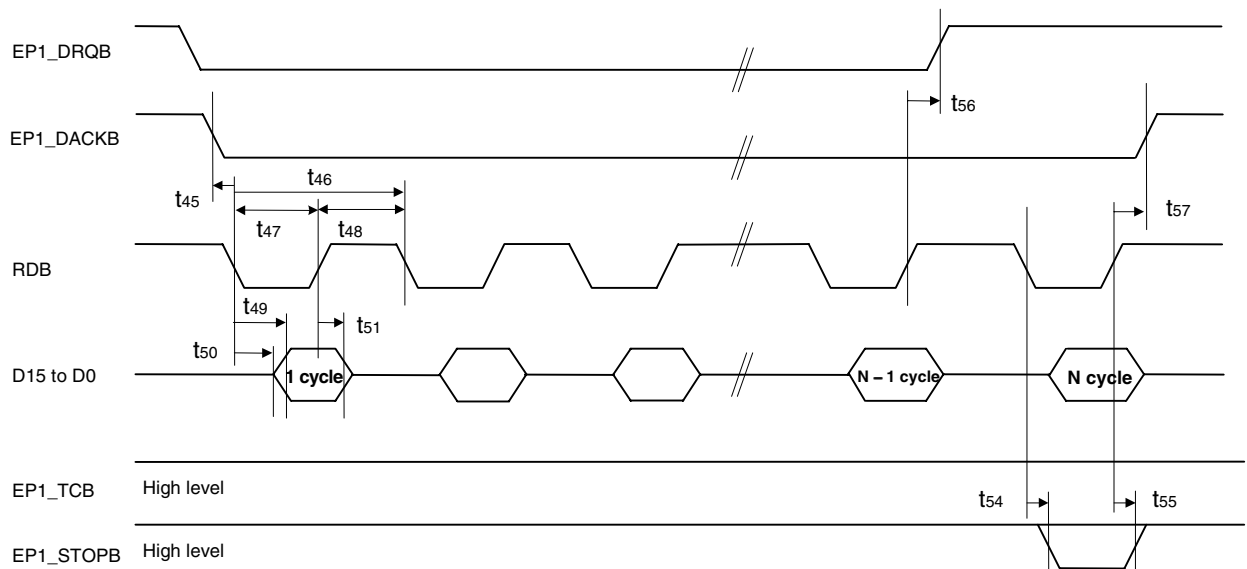

EP1\_STOPB is not asserted in the case of a full packet.

(Start timing)

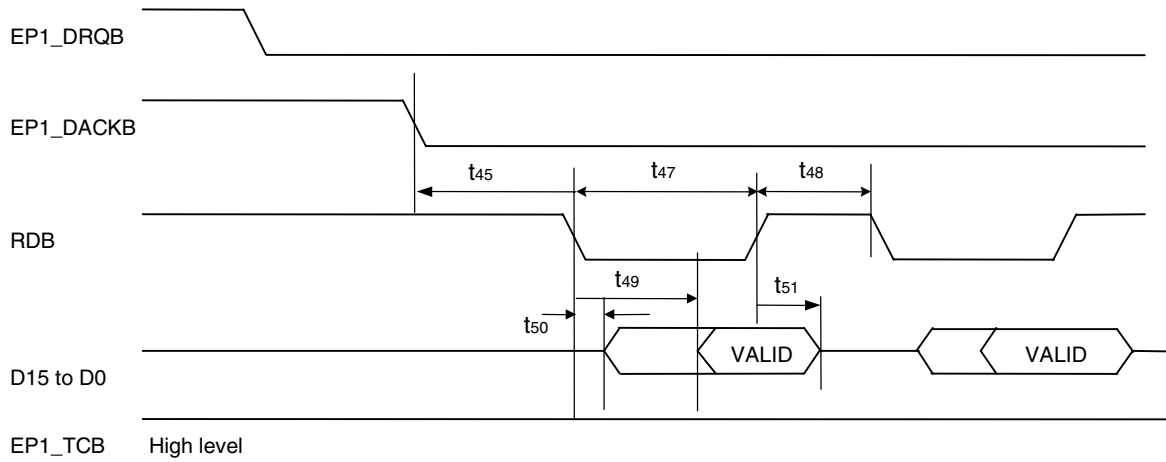

(End timing)

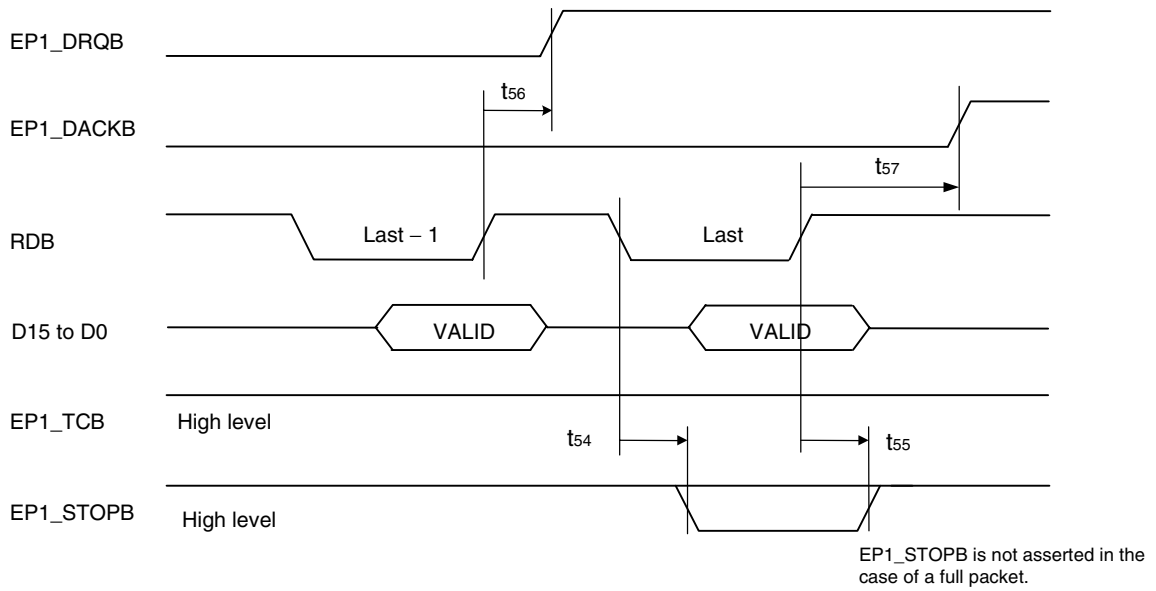

(TCB timing)

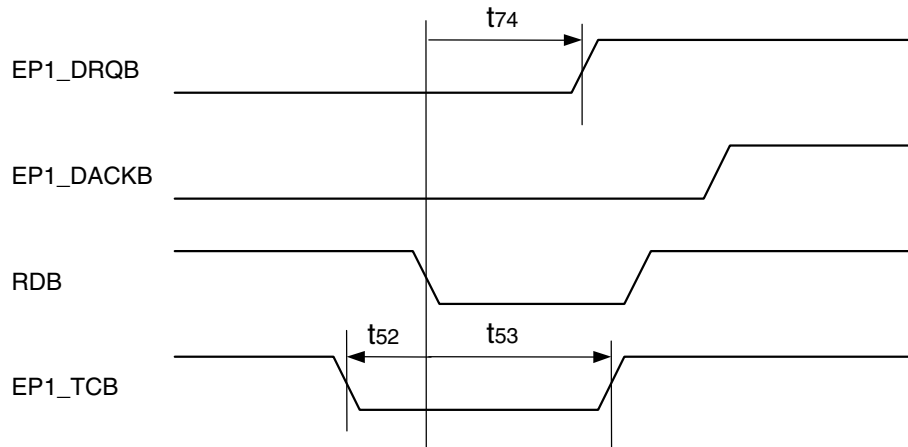

(Retransmission timing)

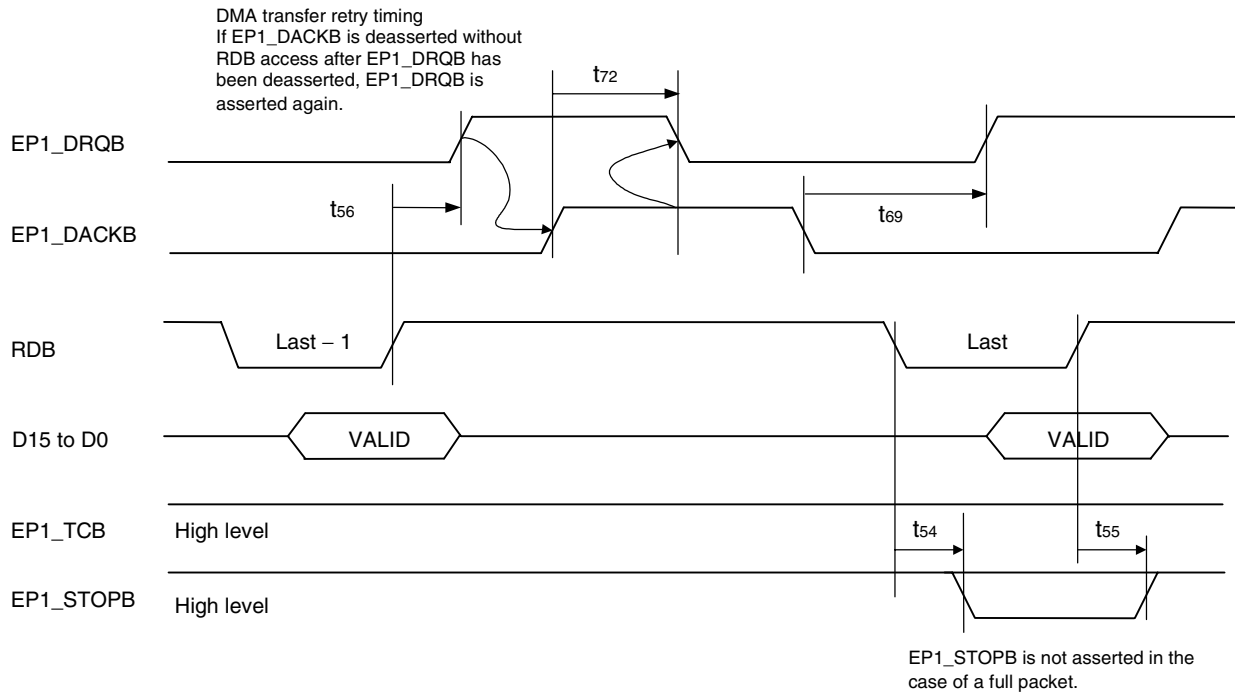



(If EP1\_TCB is input when retransmission is executed)

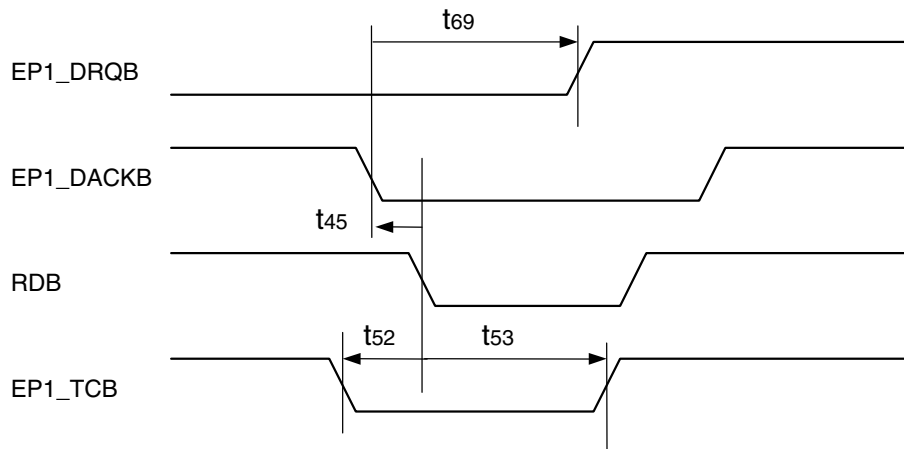

(One-cycle transfer)

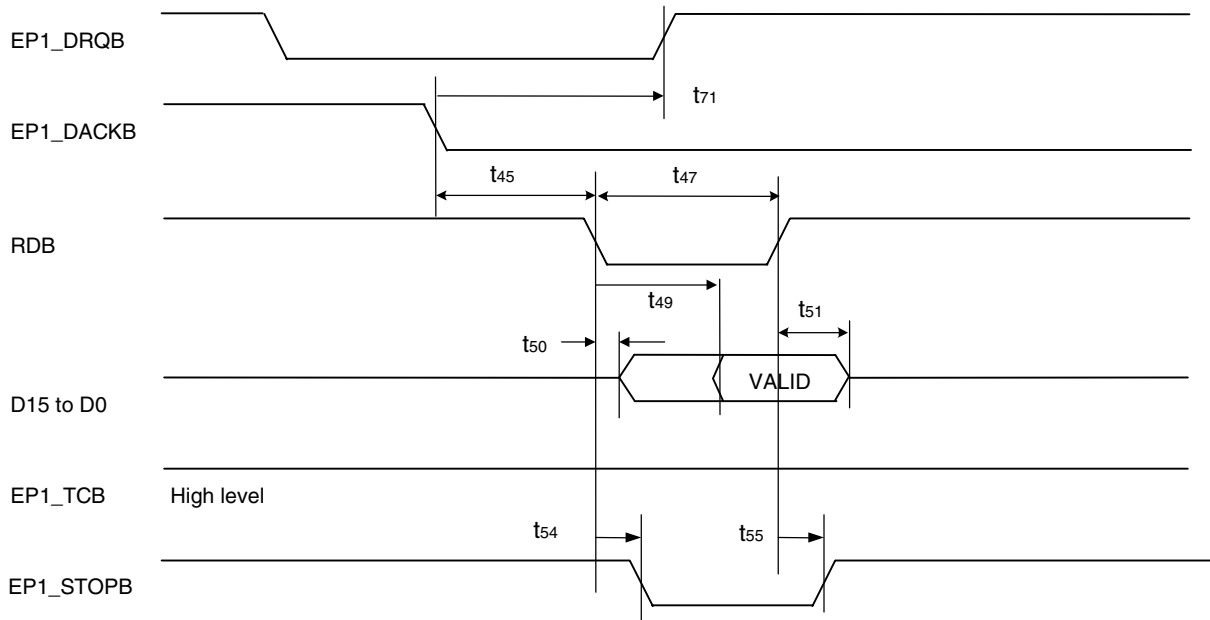

(d) CPU bus DMA demand write transfer timing

Symbol	Parameter	Min.	Typ.	Max.	Unit
T58	DMA request acknowledge setup time (WRB↓)	0		∞	ns
T59	DMA demand mode write transfer cycle time	72		∞	ns
T60	Write command width	38		∞	ns
T61	Write command inactive time	34		∞	ns
T62	Write data setup time (WRB↑)	10		∞	ns
T63	Write data hold time (WRB↑)	0		∞	ns
T64	EP2_TCB setup time (WRB↓)	0		<b>Note</b>	ns
T65	EP2_TCB hold time (WRB↓)	17		∞	ns
T66	DMA request off time (WRB↓)	–		60	ns
T67	DMA request acknowledge hold time (WRB↑)	0		∞	ns
T70	DMA request off time (EP2_DACKB↓)	–		38	ns
T73	DMA request on time (EP2_DACKB↑)	–		88	ns
T75	DMA request off time (WRB↓)	–		60	ns

**Note** Can be input after immediately previous WRB↑.

**Remark** It is assumed that the external pin capacitance is 15 pF (data bus = 50 pF).

(Overall)

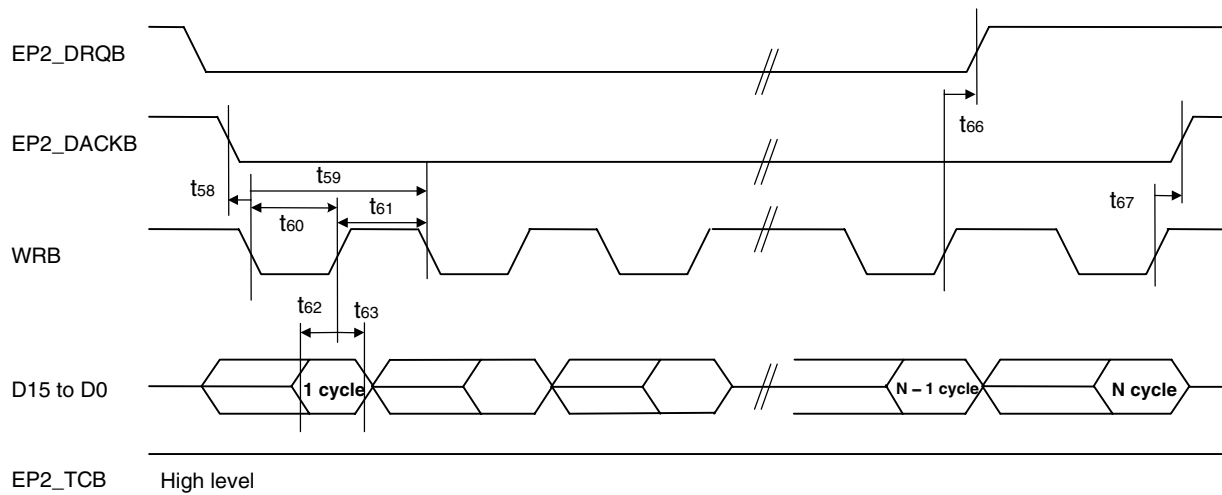

(Start timing)

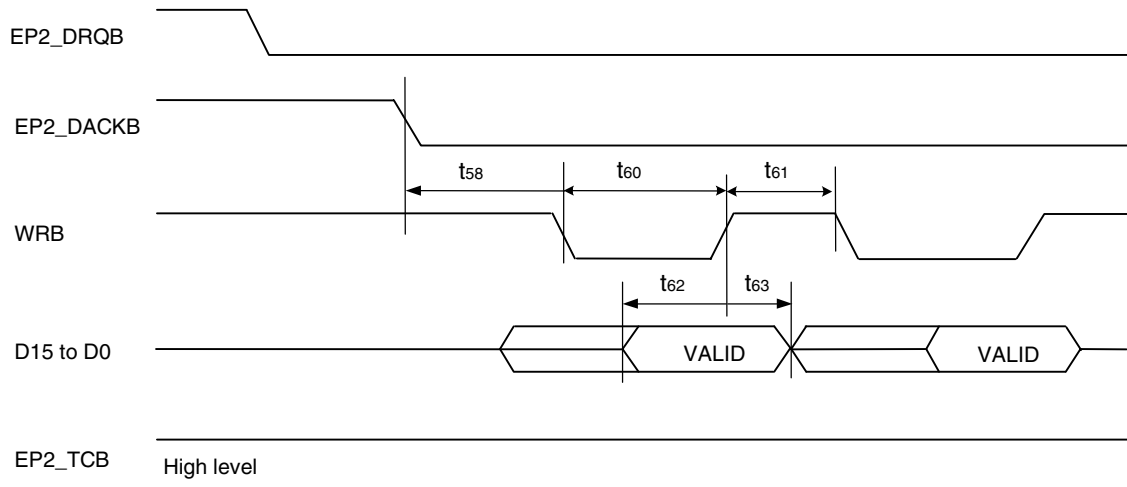

(End timing)

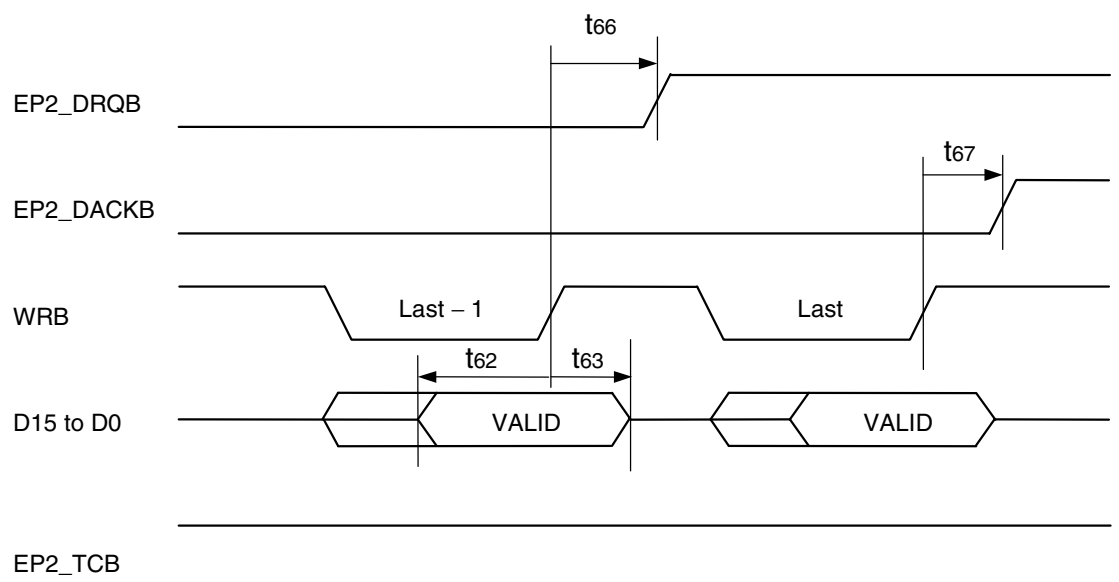

(TCB timing)

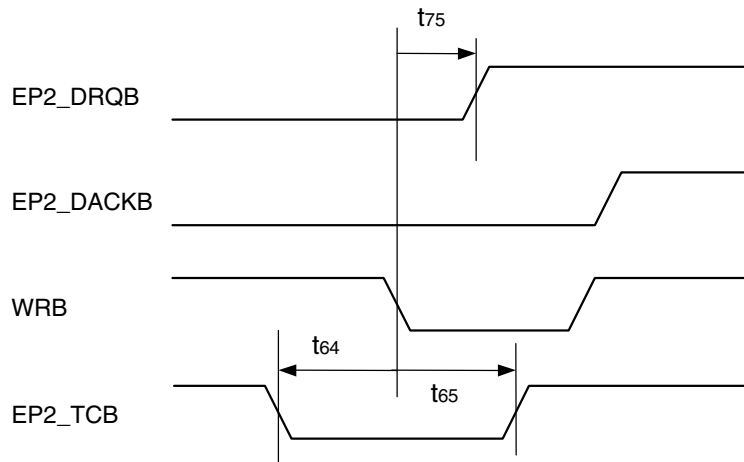

(Retransmission timing)

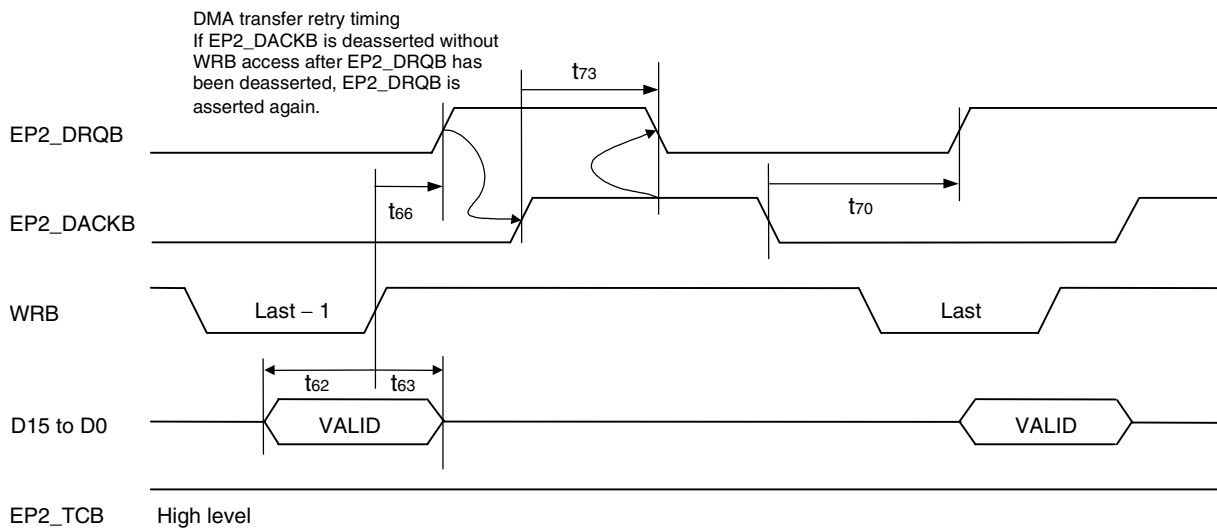

(If EP1\_TCB is input when retransmission is executed)

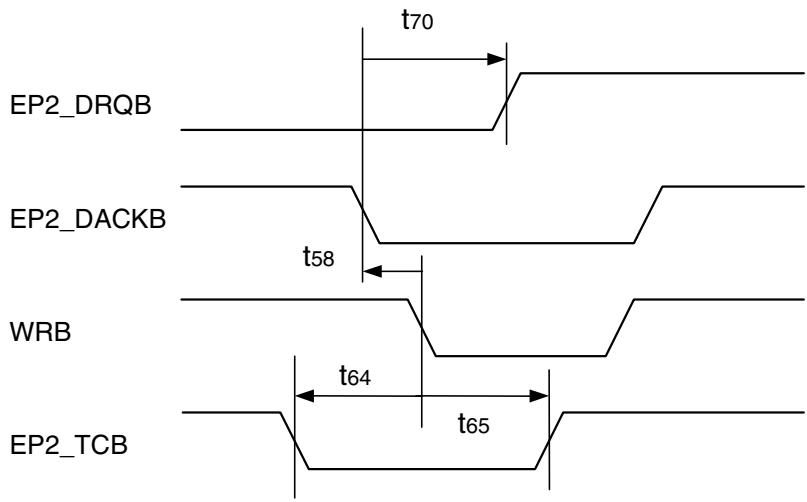

(a) CPU bus DMA read transfer vs. write transfer timing

Symbol	Parameter	Min.	Typ.	Max.	Unit
T68	RDB vs. WRB command inactive time	34		∞	ns

**Remark** It is assumed that the external pin capacitance is 15 pF (data bus = 50 pF).

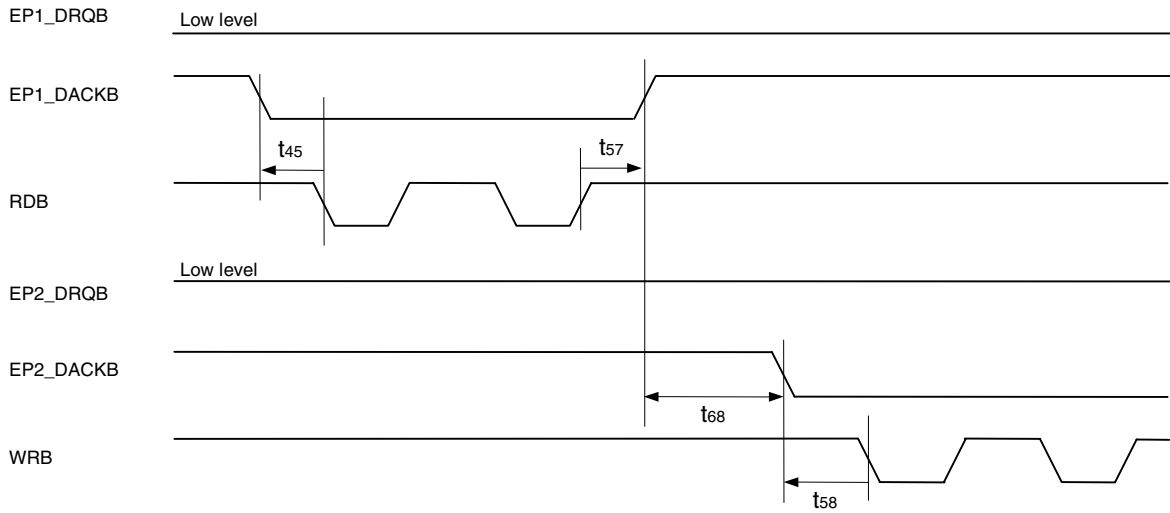

2.6.3 AC characteristics of BIU block with function 2 or 3 selected

(1) CPU bus read operation

Symbol	Parameter	Min.	Typ.	Max.	Unit
TB1	Read cycle time	86		∞	ns
TB2	Address setup time (ALE↓)	10		∞	ns
TB3	Chip select setup time (ALE↓)	17		∞	ns
TB4	Read command delay time (ALE↓)	7		∞	ns
TB5	Output data delay time (RDB↓)	–		57	ns
TB6	Read command width	57		∞	ns
TB7	Output data hold time (RDB↑)	4		–	ns
TB8	Chip select hold time (RDB↑)	5		∞	ns
TB9	ALE width	10		∞	ns
TB10	Address hold time (ALE↓)	0		∞	ns
TB11	Chip select setup time (RDB↓)	5		∞	ns
TB12	Buffer direction change time (RDB↓)	–		14	ns

**Remark** It is assumed that the external pin capacitance is 15 pF (data bus = 50 pF).

CPU bus read timing

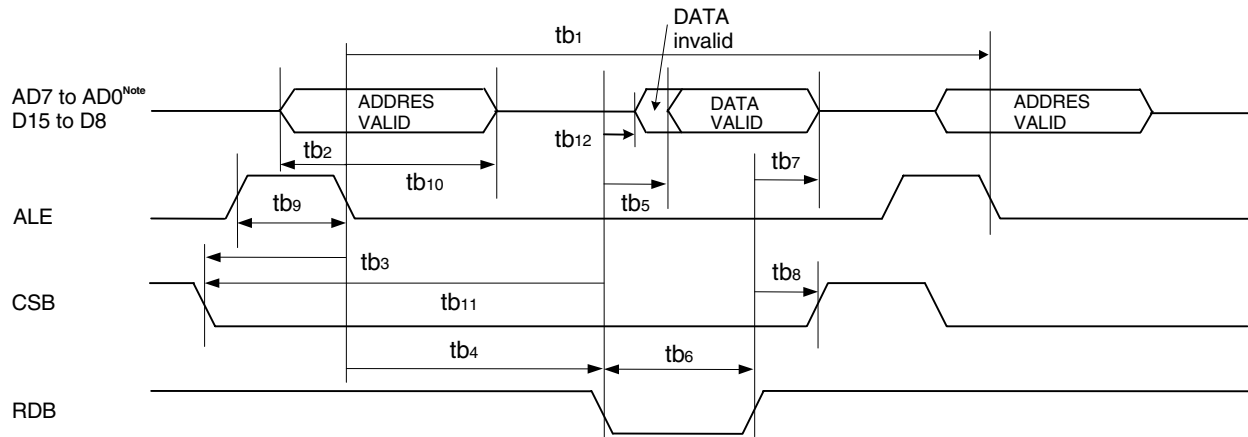

**Note** D7 to D0 for Function 2

(2) CPU bus write operation

Symbol	Parameter	Min.	Typ.	Max.	Unit
TB13	Write cycle time	58		∞	ns
TB14	Address setup time (ALE↓)	17		∞	ns
TB15	Chip select setup time (ALE↓)	17		∞	ns
TB16	Write command delay time (ALE↓)	7		∞	ns
TB17	Input data setup time (WRB↑)	10		∞	ns
TB18	Input data hold time (WRB↑)	0		∞	ns
TB19	Write command width	34		∞	ns
TB20	Chip select hold time (WRB↑)	0		∞	ns
TB21	Chip select setup time (WRB↓)	5		∞	ns

**Remark** It is assumed that the external pin capacitance is 15 pF (data bus = 50 pF).

CPU bus write timing

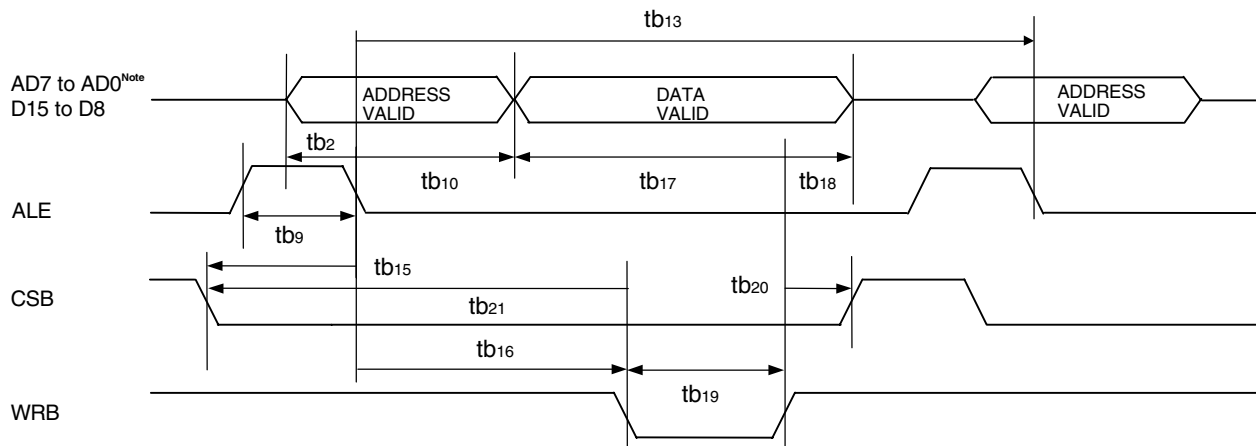

**Note** D7 to D0 for Function 2



2.6.4 External local bus

(1) External local bus 16-bit mode

(a) External local bus 16-bit mode DMA single mode read transfer timing

Symbol	Parameter	Min.	Typ.	Max.	Unit
L16T21	DMA request acknowledge setup time (EP1_RDB↓)	0		∞	ns
L16T22	DMA request off time 1 (EP1_DACKB↓)	–		54	ns
L16T23	DMA single mode read transfer cycle time	91		∞	ns
L16T24	Read command width	57		∞	ns
L16T25	Read command inactive time	34		∞	ns
L16T26	Read data delay time (EP1_RDB↓)	–		57	ns
L16T27	Buffer direction change time (EP1_RDB↓)	–		14	ns
L16T28	Read data hold time (EP1_RDB↑)	4		–	ns
L16T29	EP1_TCB setup time (EP1_RDB↓)	0		<b>Note</b>	ns
L16T30	EP1_TCB hold time (EP1_RDB↓)	17		∞	ns
L16T31	EP1_STOPB delay time (EP1_RDB↓)	–		15	ns
L16T32	EP1_STOPB delay time (EP1_RDB↑)	3		–	ns
L16T33	DMA request acknowledge hold time (EP1_RDB↑)	0		∞	ns
L16T34	Undefined	–		–	ns

**Note** Can be input after previous EP1\_RDB↑.

**Remark** It is assumed that the external pin capacitance is 15 pF (data bus = 50 pF).

(Overall)

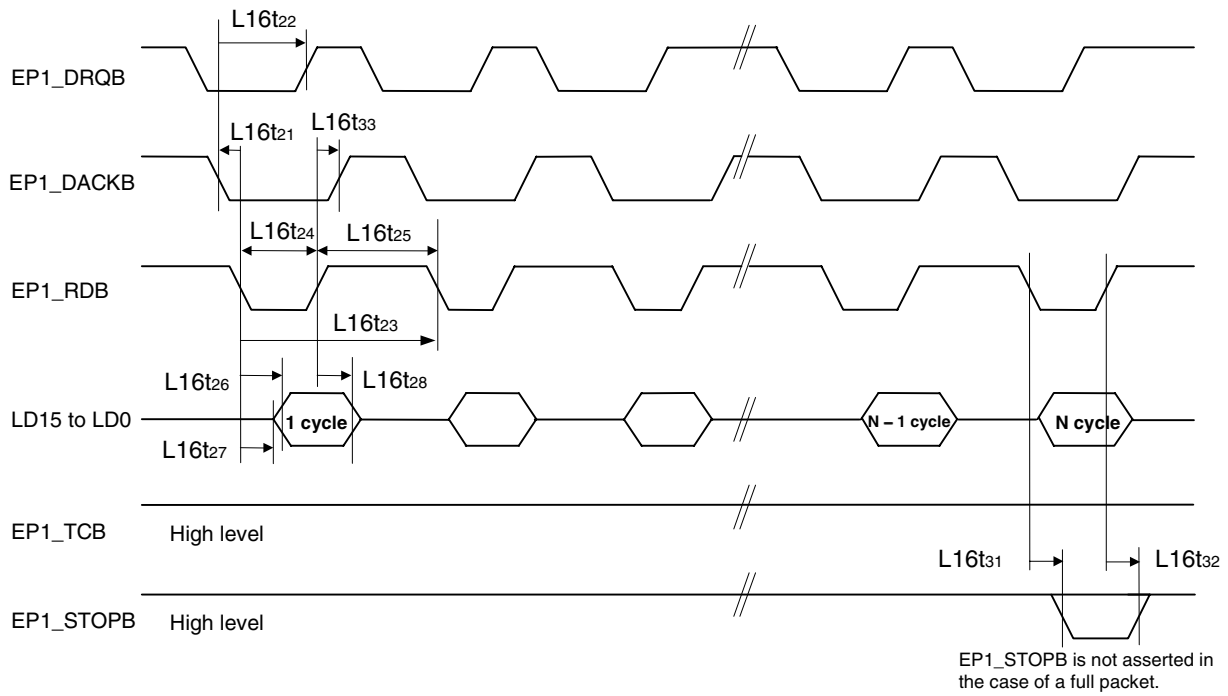

(Start timing)

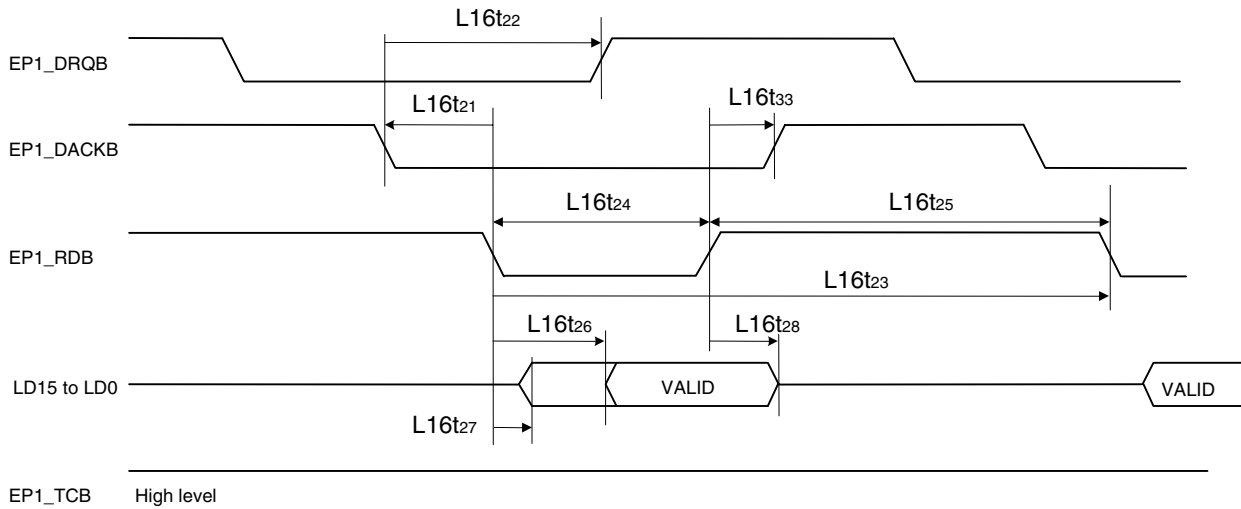

(End timing)

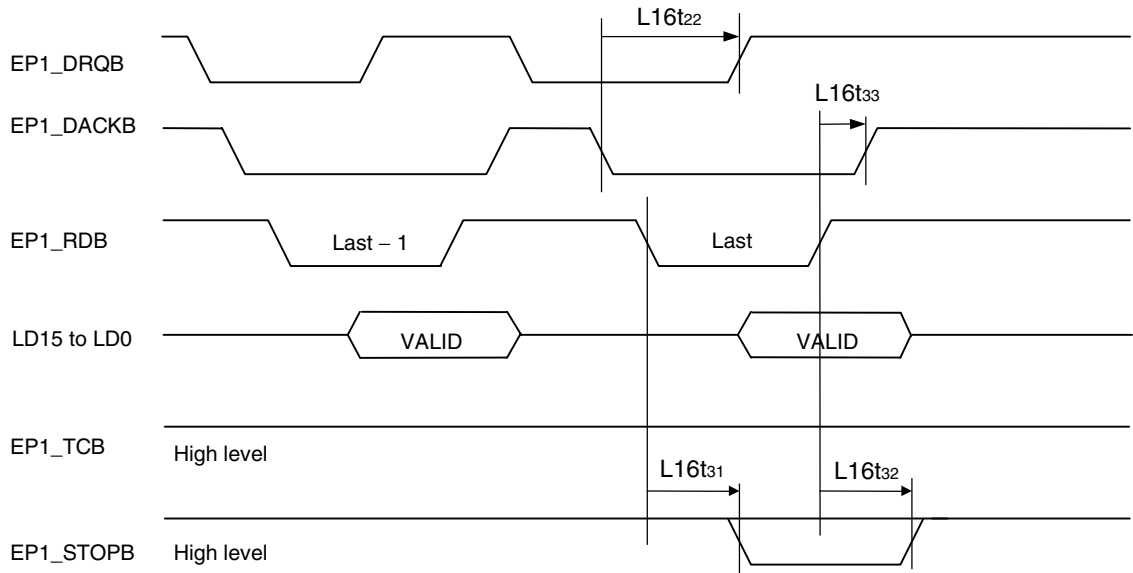

EP1\_STOPB is not asserted in the case of a full packet.

(TCB timing)

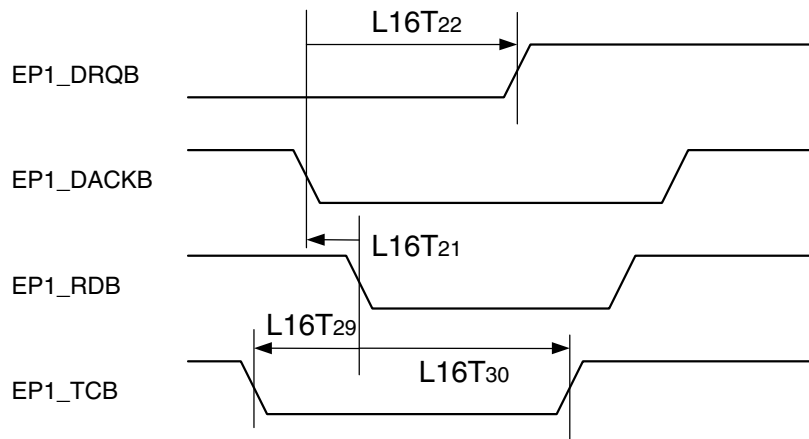

(a) External local bus 16-bit mode DMA single mode write transfer

Symbol	Parameter	Min.	Typ.	Max.	Unit
L16T35	DMA request acknowledge setup time (EP2_WRB↓)	0		∞	ns
L16T36	DMA request off time 1 (EP2_DACKB↓)	–		54	ns
L16T37	DMA single mode write transfer cycle time	88		∞	ns
L16T38	Write command width	54		∞	ns
L16T39	Write command inactive time	34		∞	ns
L16T40	Write data setup time (EP2_WRB↑)	10		∞	ns
L16T41	Write data hold time (EP2_WRB↑)	0		∞	ns
L16T42	EP2_TCB setup time (EP2_WRB↓)	0		<b>Note</b>	ns
L16T43	EP2_TCB hold time (EP2_WRB↓)	17		∞	ns
L16T44	DMA request acknowledge hold time (EP2_WRB↑)	0		∞	ns

**Note** Can be input after previous EP2\_WRB↑.

**Remark** It is assumed that the external pin capacitance is 15 pF (data bus = 50 pF).

(Overall)

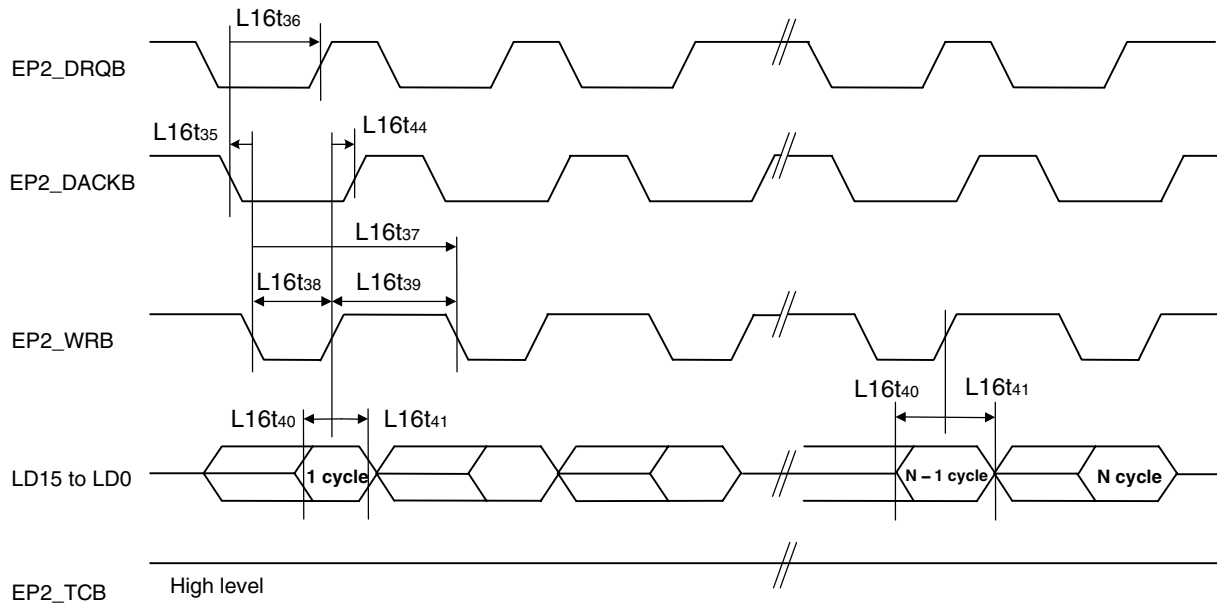

(Start timing)

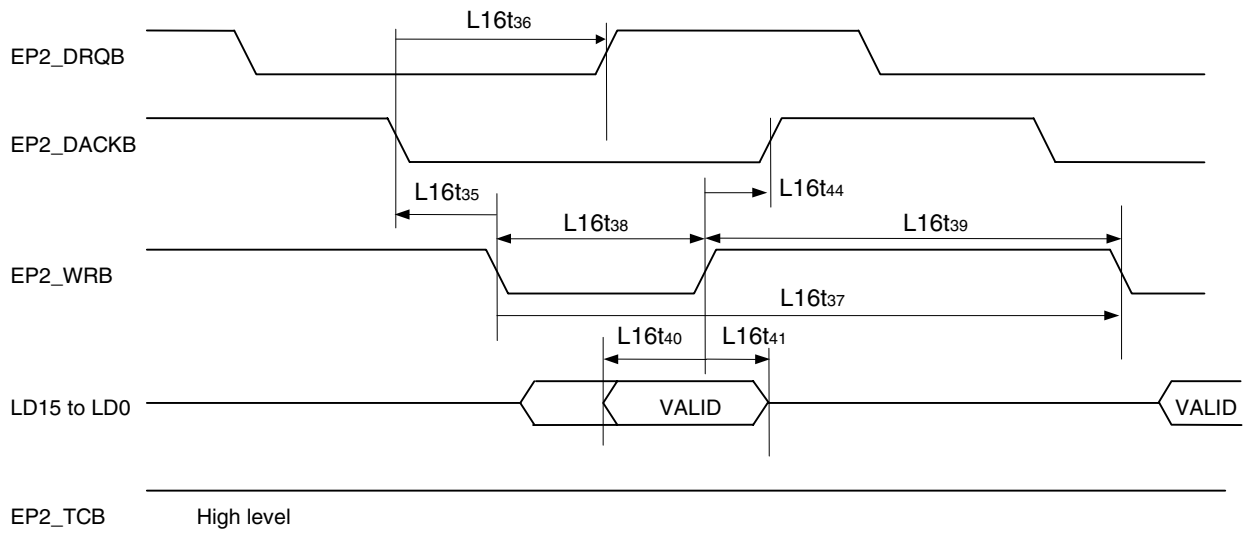

(End timing)

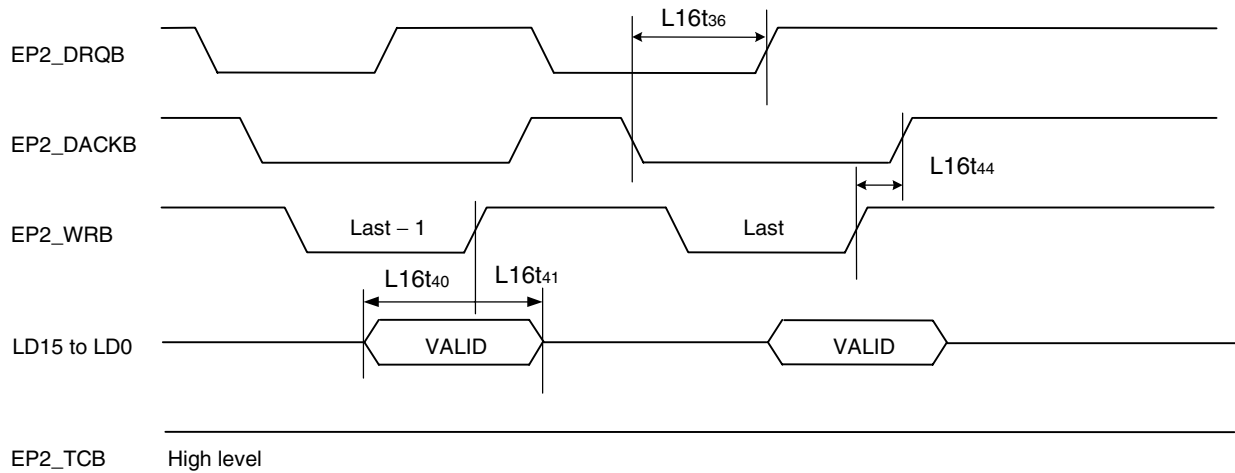

(TCB timing)

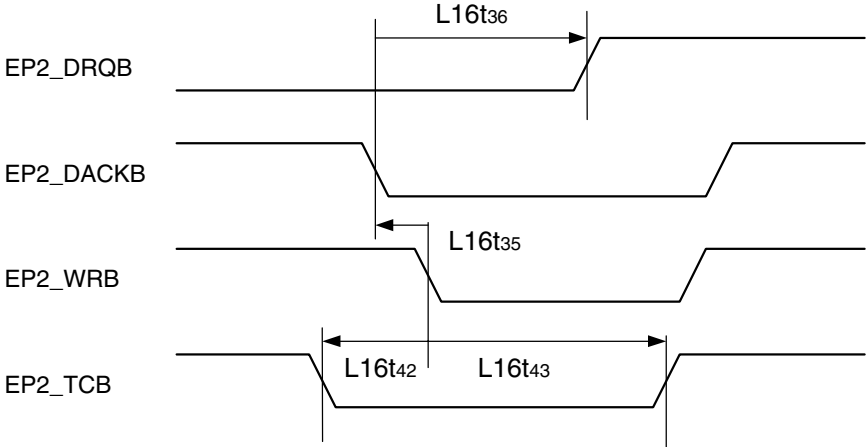

(c) External local bus 16-bit mode DMA demand read transfer timing

Symbol	Parameter	Min.	Typ.	Max.	Unit
L16T45	DMA request acknowledge setup time (EP1_RDB↓)	0		∞	ns
L16T46	DMA demand mode read transfer cycle time	91		∞	ns
L16T47	Read command width	57		∞	ns
L16T48	Read command inactive time	34		∞	ns
L16T49	Read data delay time (EP1_RDB↓)	–		57	ns
L16T50	Buffer direction change time (EP1_RDB↓)	–		14	ns
L16T51	Read data hold time (EP1_RDB↑)	4		–	ns
L16T52	EP1_TCB setup time (EP1_RDB↓)	0		<b>Note</b>	ns
L16T53	EP1_TCB hold time (EP1_RDB↓)	17		∞	ns
L16T54	EP1_STOPB delay time (EP1_RDB↓)	–		15	ns
L16T55	EP1_STOPB delay time (EP1_RDB↑)	3		–	ns
L16T56	DMA request off time (EP1_RDB↑)	–		59	ns
L16T57	DMA request acknowledge hold time (EP1_RDB↑)	0		∞	ns
L16T69	DMA request off time (EP1_DACKB↓)	–		38	ns
L16T71	DMA request off time (EP1_DACKB↓) 1 cycle transfer	–		38	ns
L16T72	DMA request on time (EP1_DACKB↑)	–		88	ns
L16T74	DMA request off time (EP1_RDB↓)	–		60	ns

**Note** Can be input after immediately previous EP1\_RDB↑.

**Remark** It is assumed that the external pin capacitance is 15 pF (data bus = 50 pF).

(Overall)

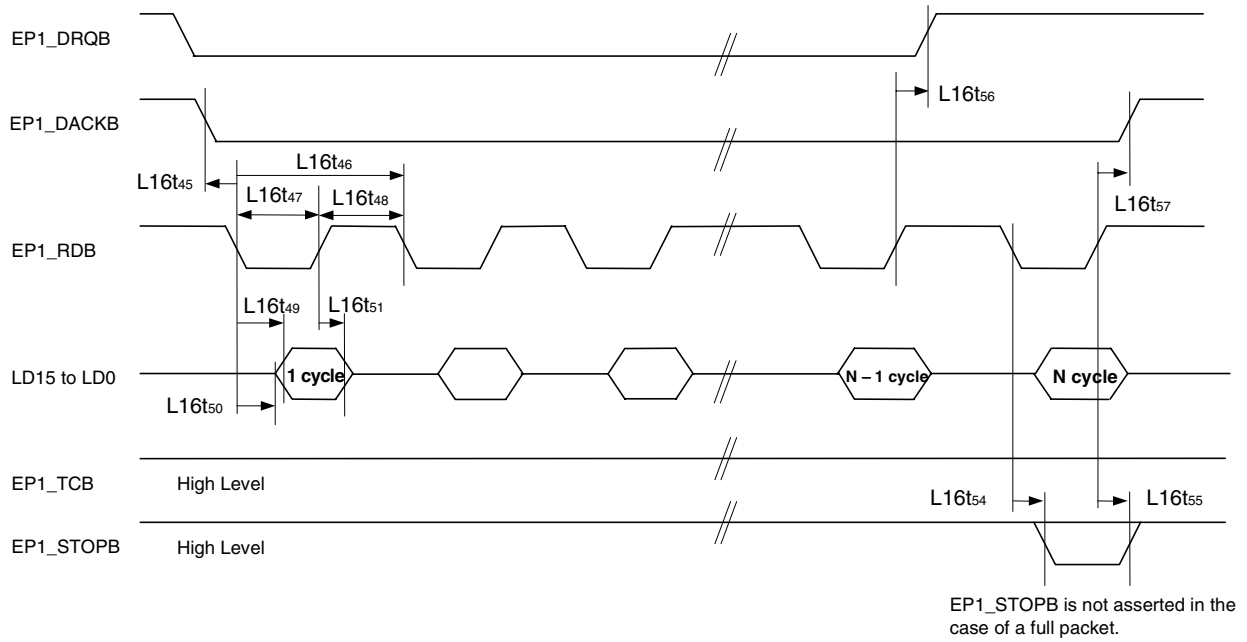

(Start timing)

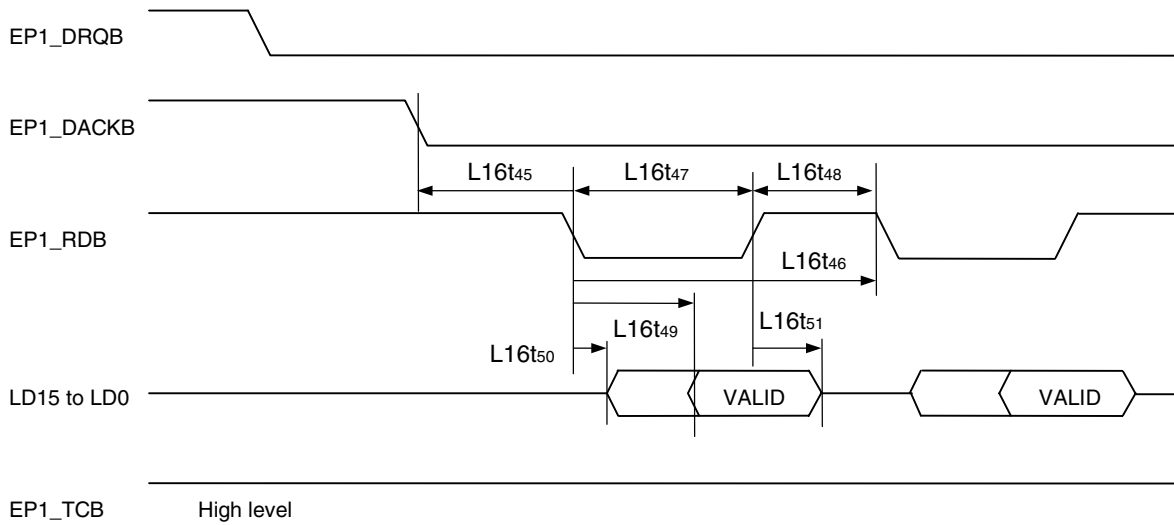



**(End timing)**

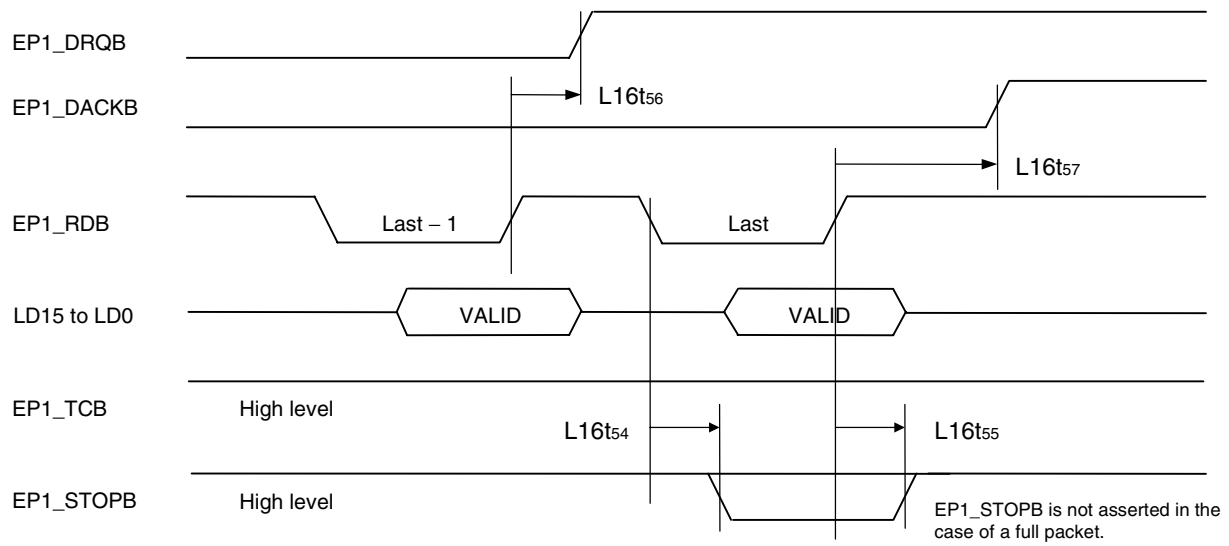

**(TCB timing)**

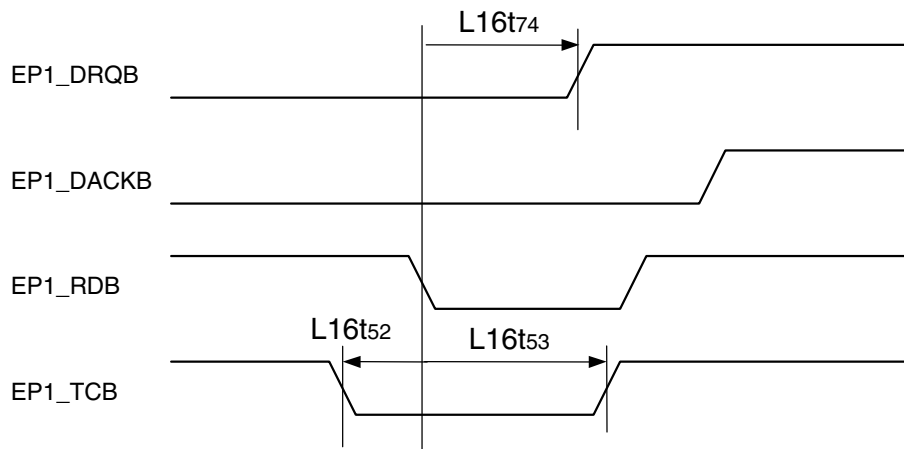

**(Retransmission timing)**

DMA transfer retry timing  
 If EP1\_DACKB is deasserted without RDB access after EP1\_DRQB has been deasserted, EP1\_DRQB is asserted again. However, note that the retry operation cannot be performed in the 8-bit mode.

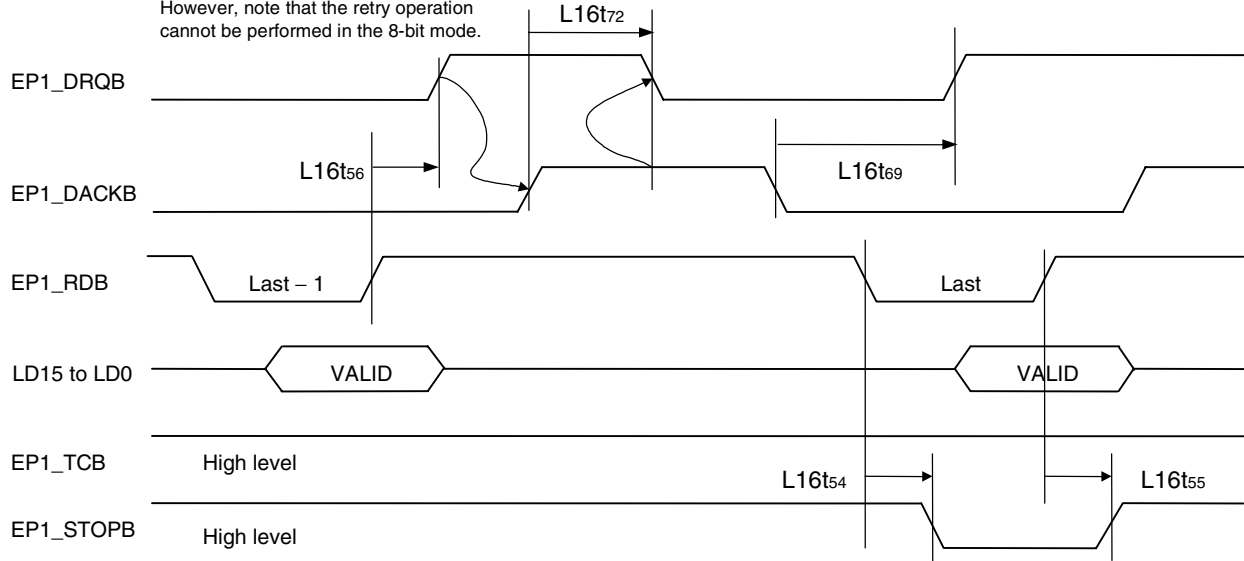

EP1\_STOPB is not asserted in the case of a full packet.

**(If EP1\_TCB is input when retransmission is executed)**

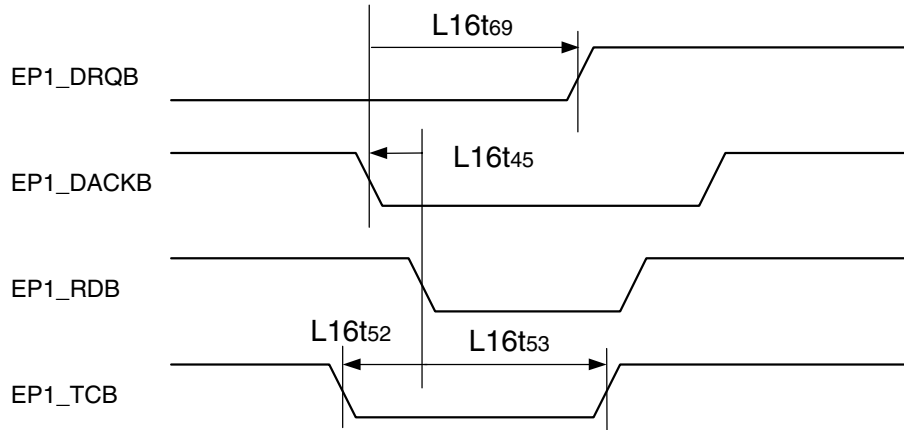

(One-cycle transfer)

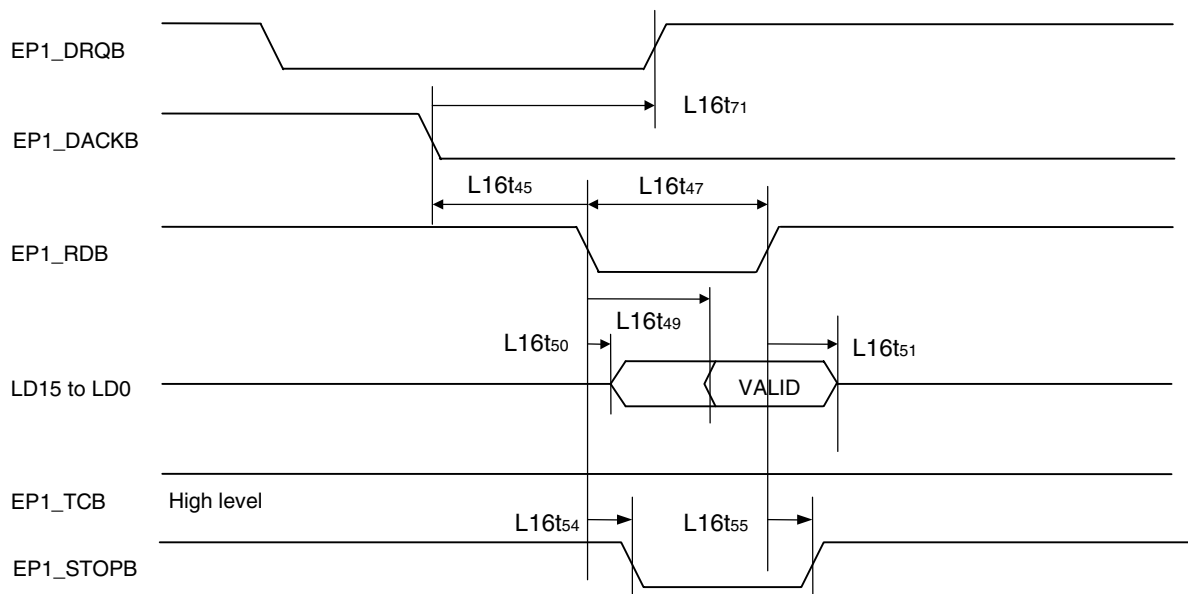

(d) External local bus 16-bit mode DMA demand write transfer timing

Symbol	Parameter	Min.	Typ.	Max.	Unit
L16T58	DMA request acknowledge setup time (EP2_WRB↓)	0		∞	ns
L16T59	DMA demand mode write transfer cycle time	72		∞	ns
L16T60	Write command width	38		∞	ns
L16T61	Write command inactive time	34		∞	ns
L16T62	Write data setup time (EP2_WRB↑)	10		∞	ns
L16T63	Write data hold time (EP2_WRB↑)	0		∞	ns
L16T64	EP2_TCB setup time (EP2_WRB↓)	0		<b>Note</b>	ns
L16T65	EP2_TCB hold time (EP2_WRB↓)	17		∞	ns
L16T66	DMA request off time (EP2_WRB↑)	–		60	ns
L16T67	DMA request acknowledge hold time (EP2_WRB↑)	0		∞	ns
L16T70	DMA request off time (EP2_DACKB↓)	–		38	ns
L16T73	DMA request on time (EP2_DACKB↑)	–		88	ns
L16T75	DMA request off time (EP2_WRB↓)	–		60	ns

**Note** Can be input after previous EP2\_WRB↑.

**Remark** It is assumed that the external pin capacitance is 15 pF (data bus = 50 pF).

(Overall)

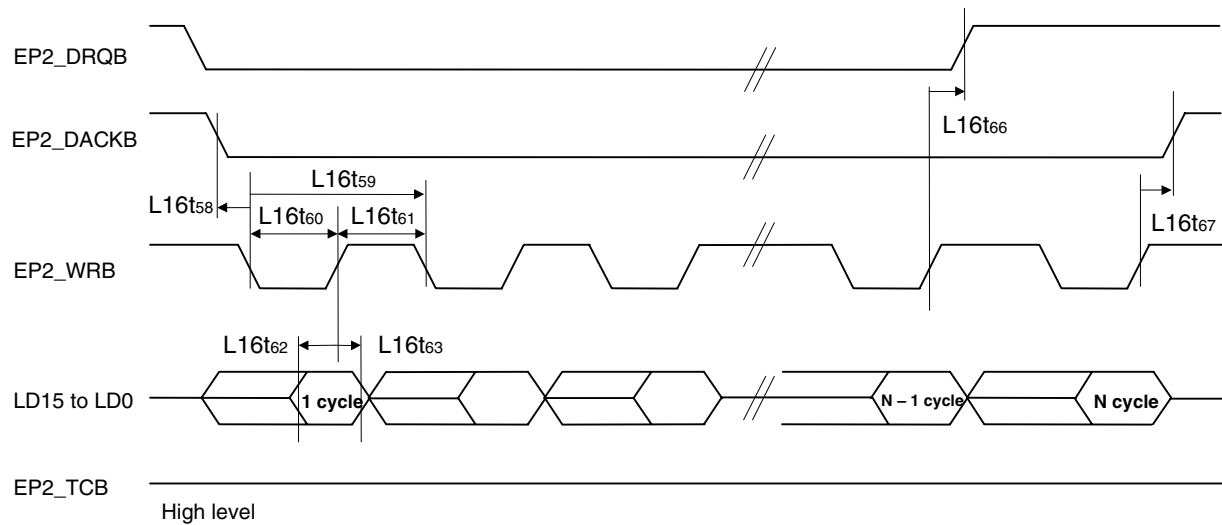

**(Start timing)**

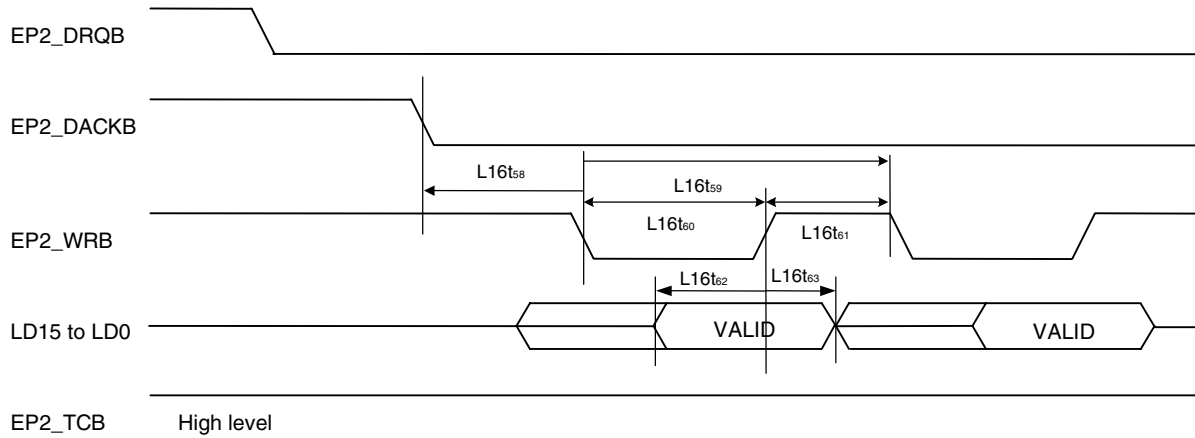

**(End timing)**

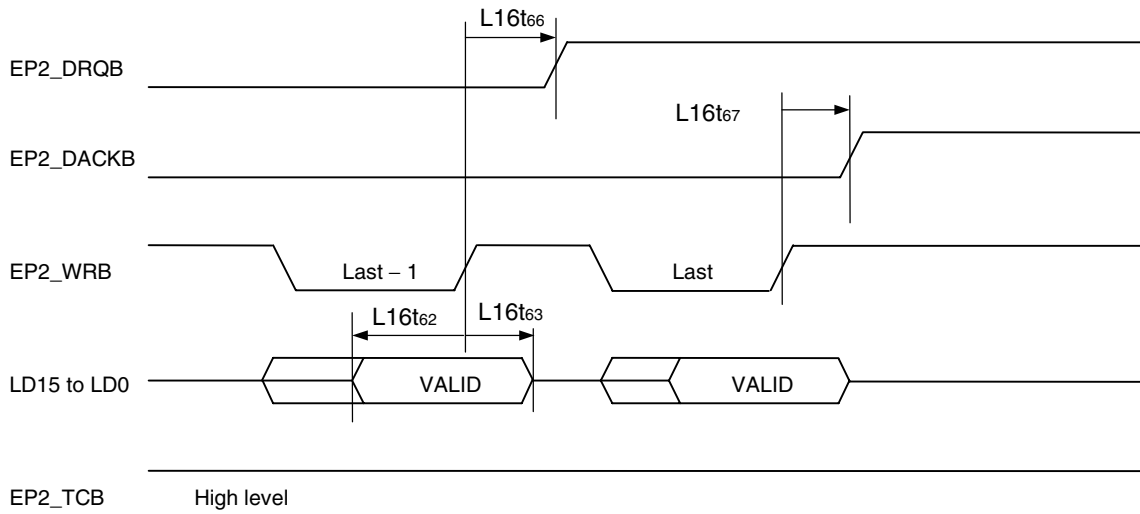

(TCB timing)

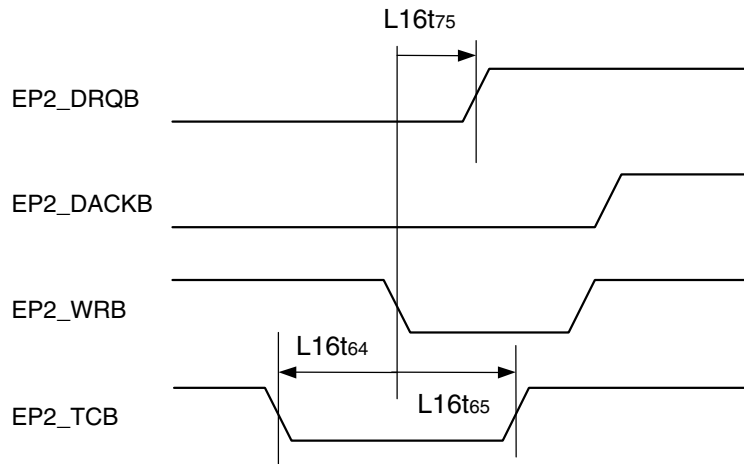

(Retransmission timing)

DMA transfer retry timing  
 If EP2\_DACKB is deasserted without RDB access after EP2\_DRQB has been deasserted, EP2\_DRQB is asserted again. However, note that the retry operation cannot be performed in the 8-bit mode.

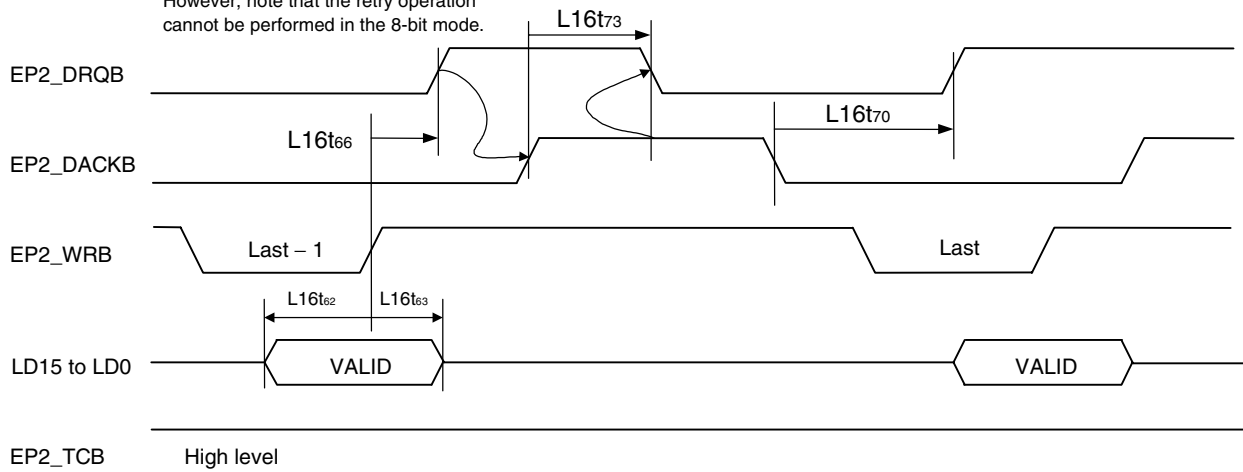

(If EP1\_TCB is input when retransmission is executed)

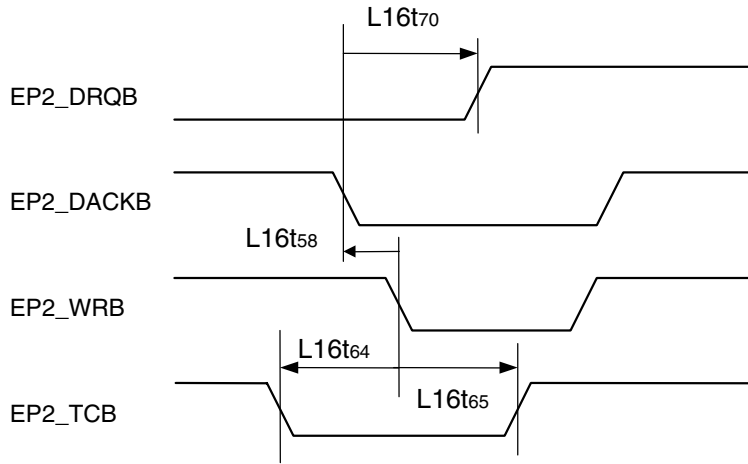

(e) External local bus 16-bit mode DMA EP1\_Read transfer vs. EP2\_Write transfer timing

Symbol	Parameter	Min.	Typ.	Max.	Unit
L16T68	EP1_RDB vs. EP2_WRB command inactive time	34		∞	ns

**Remark** It is assumed that the external pin capacitance is 15 pF (data bus = 50 pF).

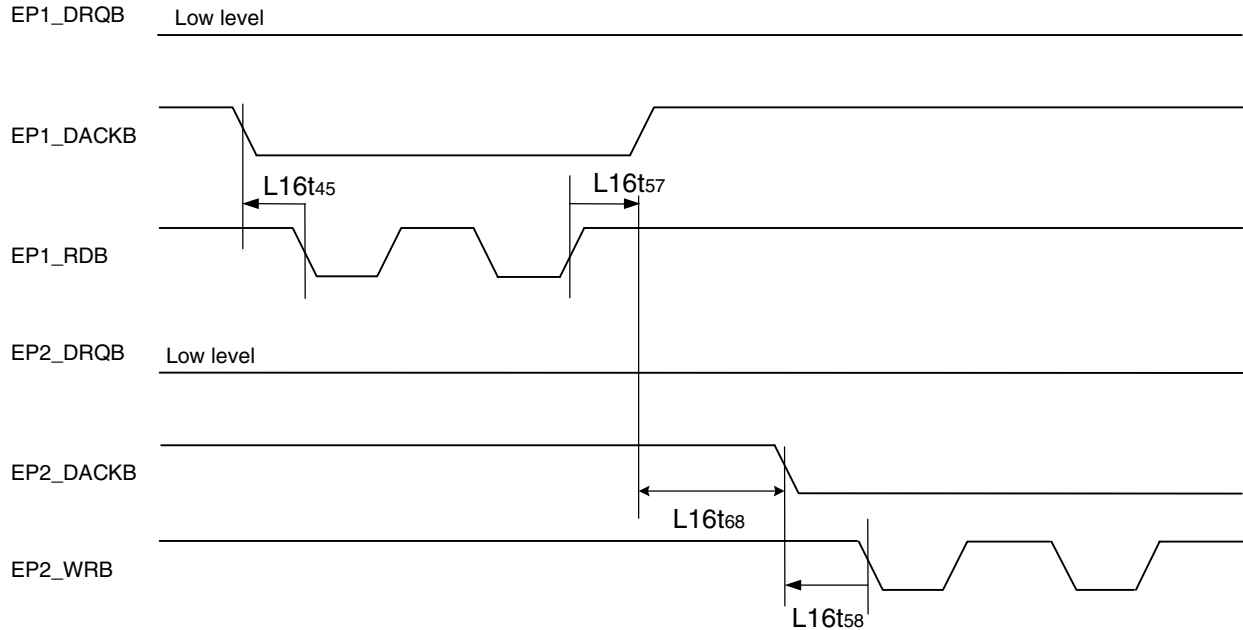

(2) External local bus 8-bit mode

(a) External local bus 8-bit mode DMA single mode read transfer timing

Symbol	Parameter	Min.	Typ.	Max.	Unit
L8T21	DMA request acknowledge setup time (EP1_RDB↓)	0		∞	ns
L8T22	DMA request off time 1 (EP1_DACKB↓)	–		10	ns
L8T23	DMA single mode read transfer cycle time	91		∞	ns
L8T24	Read command width	57		∞	ns
L8T25	Read command inactive time	34		∞	ns
L8T26	Read data delay time (EP1_RDB↓)	–		57	ns
L8T27	Buffer direction change time (EP1_RDB↓)	–		14	ns
L8T28	Read data hold time (EP1_RDB↑)	4		–	ns
L8T31	EP1_STOPB delay time (EP1_RDB↓)	–		15	ns
L8T32	EP1_STOPB delay time (EP1_RDB↑)	3		–	ns
L8T33	DMA request acknowledge hold time (EP1_RDB↑)	0		∞	ns
L8T34	Undefined	–		–	ns

- Remarks 1.** Use of EP1\_TCB is prohibited in the 8-bit external local bus mode. Clamp this signal to the inactive status.
- 2.** LD15 to 8 are undefined in the 8-bit external local bus mode (these signals are invalid when input and undefined when output).
- 3.** It is assumed that the external pin capacitance is 15 pF (data bus = 50 pF).

(Overall)

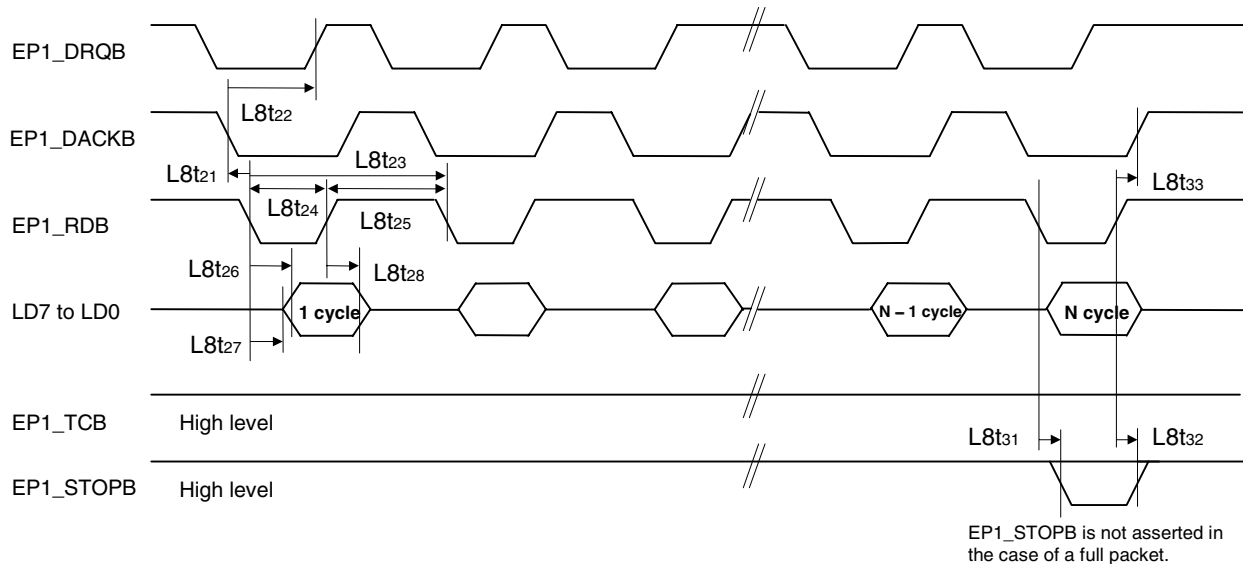



(Start timing)

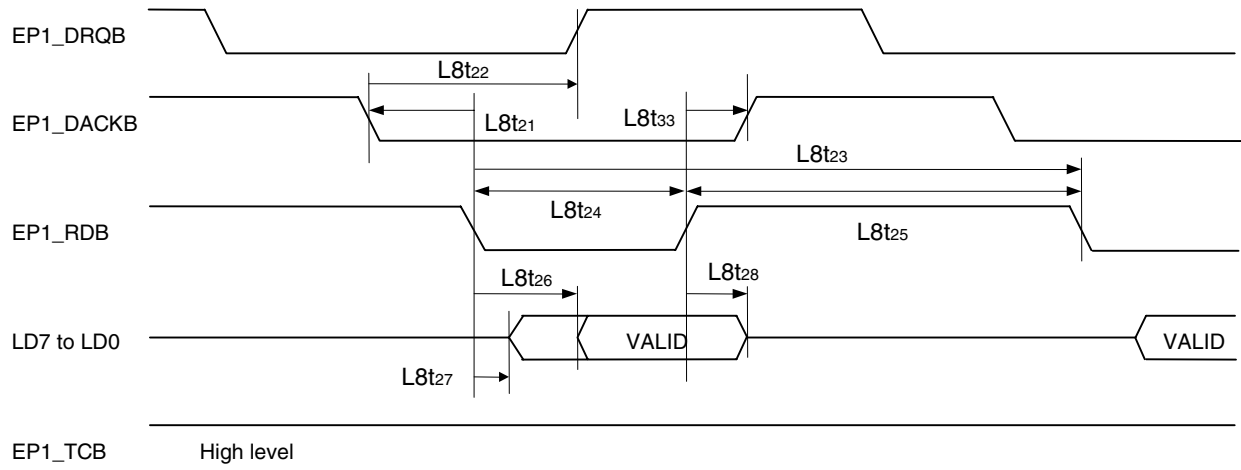

(End timing)

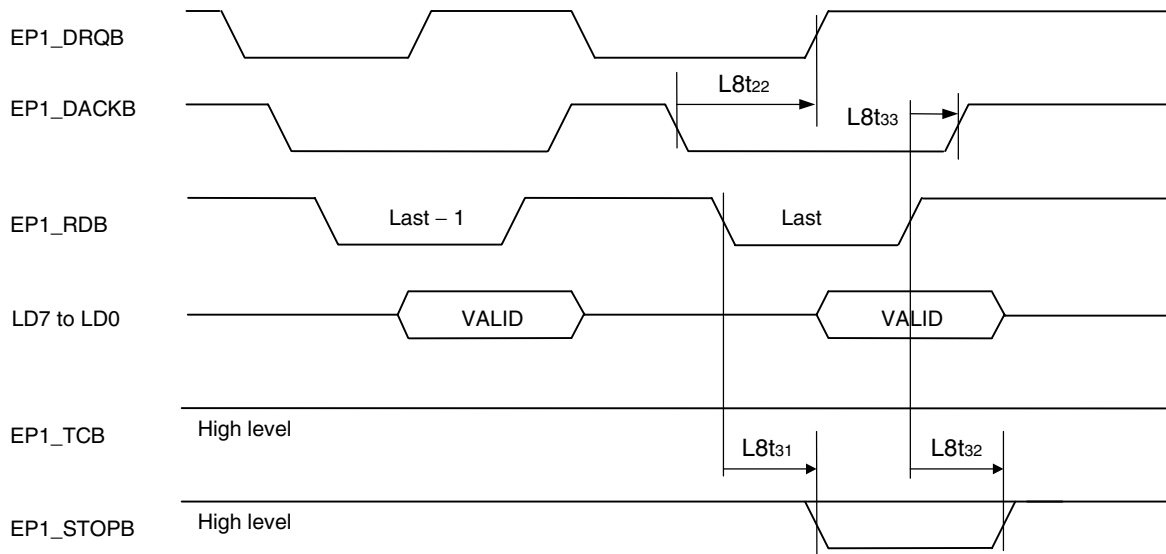

EP1\_STOPB is not asserted in the case of a full packet.

(b) External local bus 8-bit mode DMA single mode write transfer

Symbol	Parameter	Min.	Typ.	Max.	Unit
L8T35	DMA request acknowledge setup time (EP2_WRB↓)	0		∞	ns
L8T36	DMA request off time 1 (EP2_DACKB↓)	–		54 <sup>Note</sup>	ns
L8T37	DMA single mode write transfer cycle time	88		∞	ns
L8T38	Write command width	54		∞	ns
L8T39	Write command inactive time	34		∞	ns
L8T40	Write data setup time (EP2_WRB↑)	10		∞	ns
L8T41	Write data hold time (EP2_WRB↑)	0		∞	ns
L8T44	DMA request acknowledge hold time (EP2_WRB↑)	0		∞	ns

- Remarks 1.** Use of EP1\_TCB is prohibited in the 8-bit external local bus mode. Clamp this signal to the inactive status.
- 2.** LD15 to 8 are undefined in the 8-bit external local bus mode (these signals are invalid when input and undefined when output).
- 3.** It is assumed that the external pin capacitance is 15 pF (data bus = 50 pF).

**Note** The difference in specifications when compared with L8T22 is that BIU processing is performed for EP1 and that EPC2 processing is performed for EP2.

(Overall)

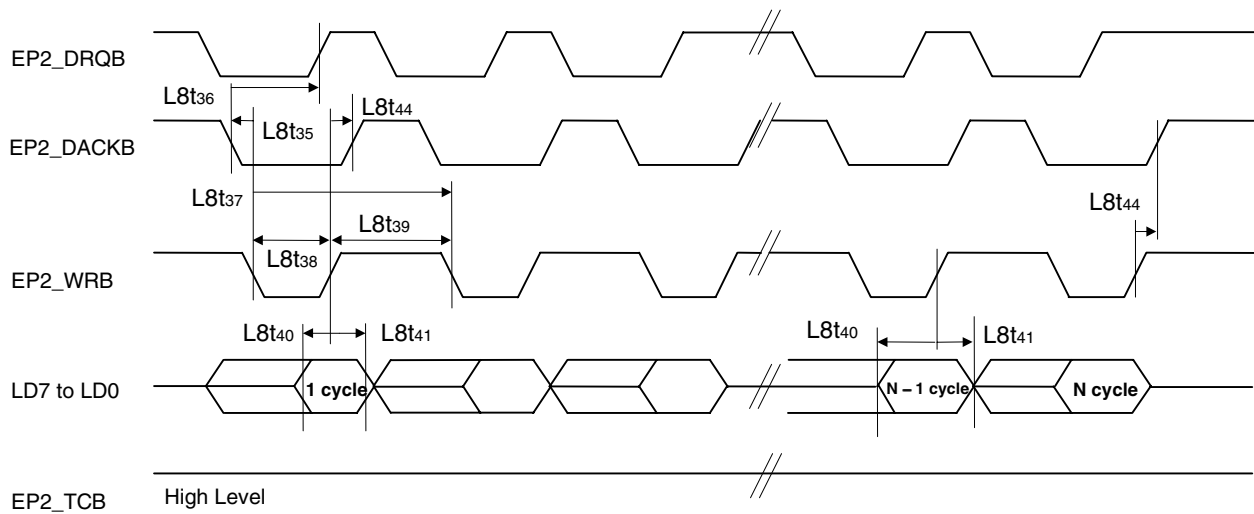

(Start timing)

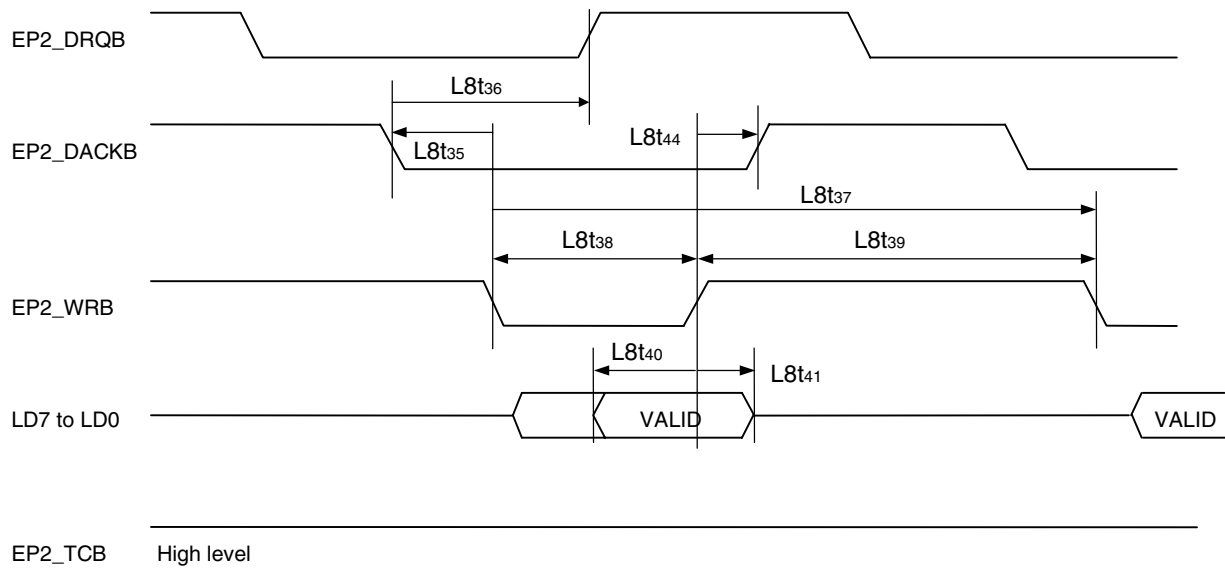

(End timing)

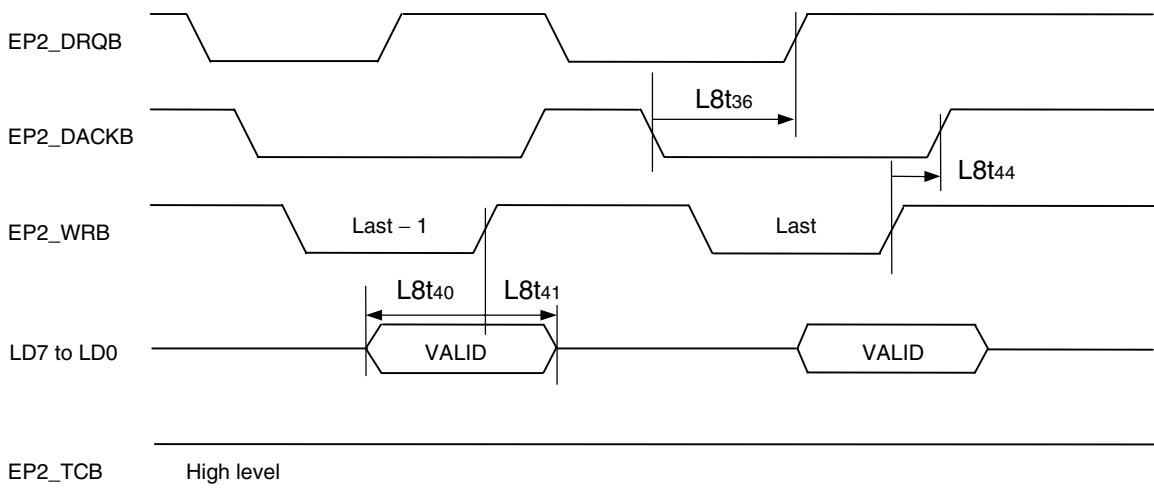

(c) External local bus 8-bit mode DMA demand read transfer timing

Symbol	Parameter	Min.	Typ.	Max.	Unit
L8T45	DMA request acknowledge setup time (EP1_RDB↓)	0		∞	ns
L8T46	DMA demand mode read transfer cycle time	90		∞	ns
L8T47	Read command width	56		∞	ns
L8T48	Read command inactive time	34		∞	ns
L8T49	Read data delay time (EP1_RDB↓)	–		56	ns
L8T50	Buffer direction change time (EP1_RDB↓)	–		14	ns
L8T51	Read data hold time (EP1_RDB↑)	4		–	ns
L8T54	EP1_STOPB delay time (EP1_RDB↓)	–		15	ns
L8T55	EP1_STOPB delay time (EP1_RDB↑)	3		–	ns
L8T56	DMA request off time (EP1_RDB↑)	–		60	ns
L8T57	DMA request acknowledge hold time (EP1_RDB↑)	0		∞	ns

- Remarks 1.** Use of EP1\_TCB is prohibited in the 8-bit external local bus mode. Clamp this signal to the inactive status.
- 2.** LD15 to 8 are undefined in the 8-bit external local bus mode (these signals are invalid when input and undefined when output).
- 3.** It is assumed that the external pin capacitance is 15 pF (data bus = 50 pF).

(Overall)

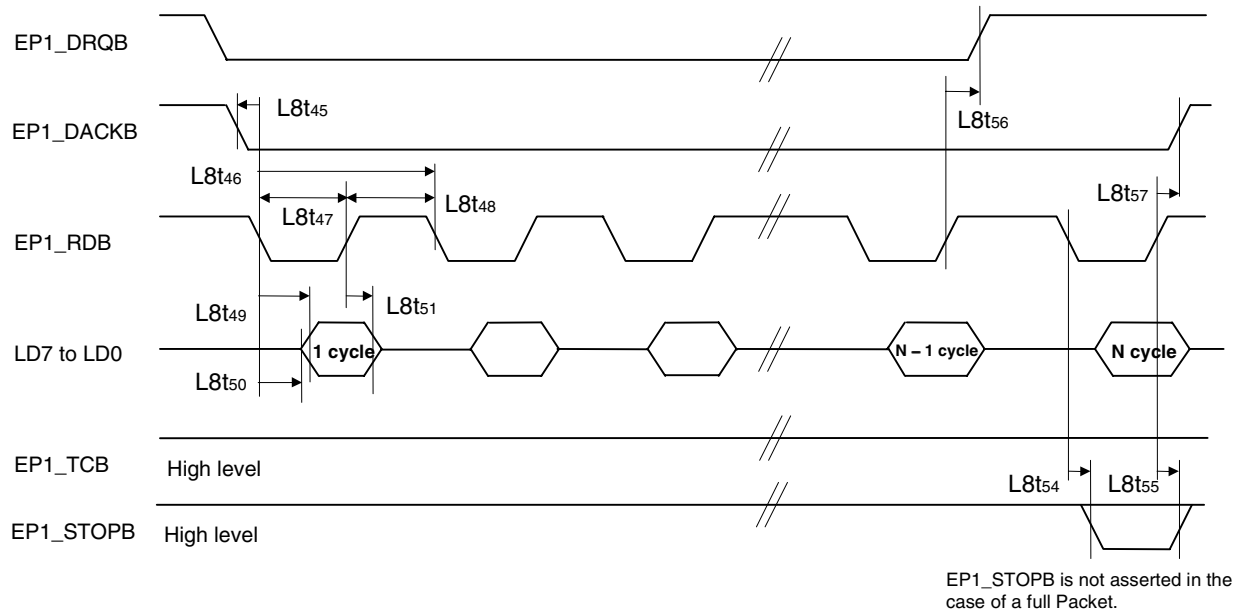

(Start timing)

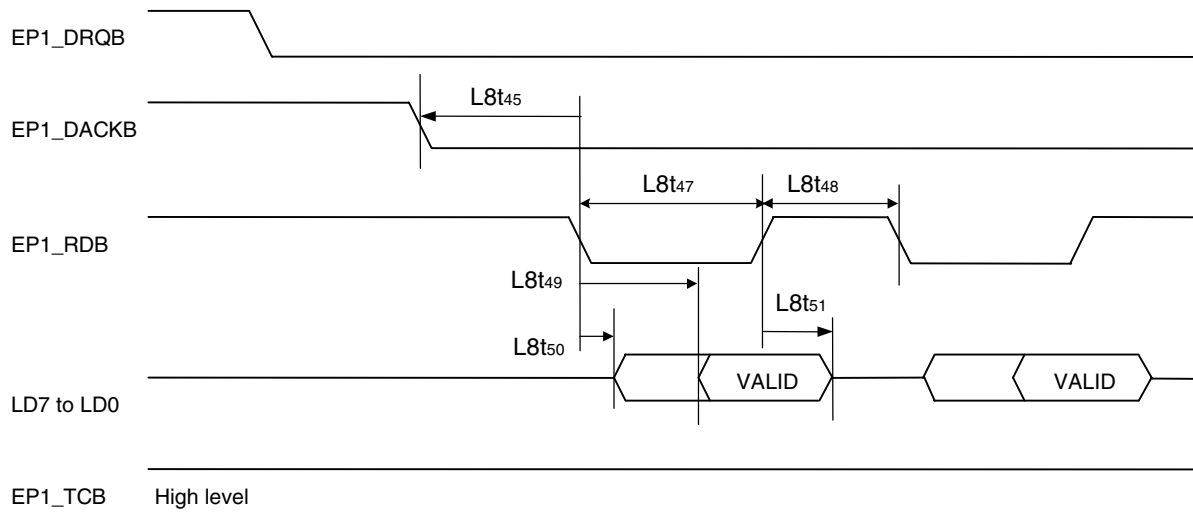

(End timing)

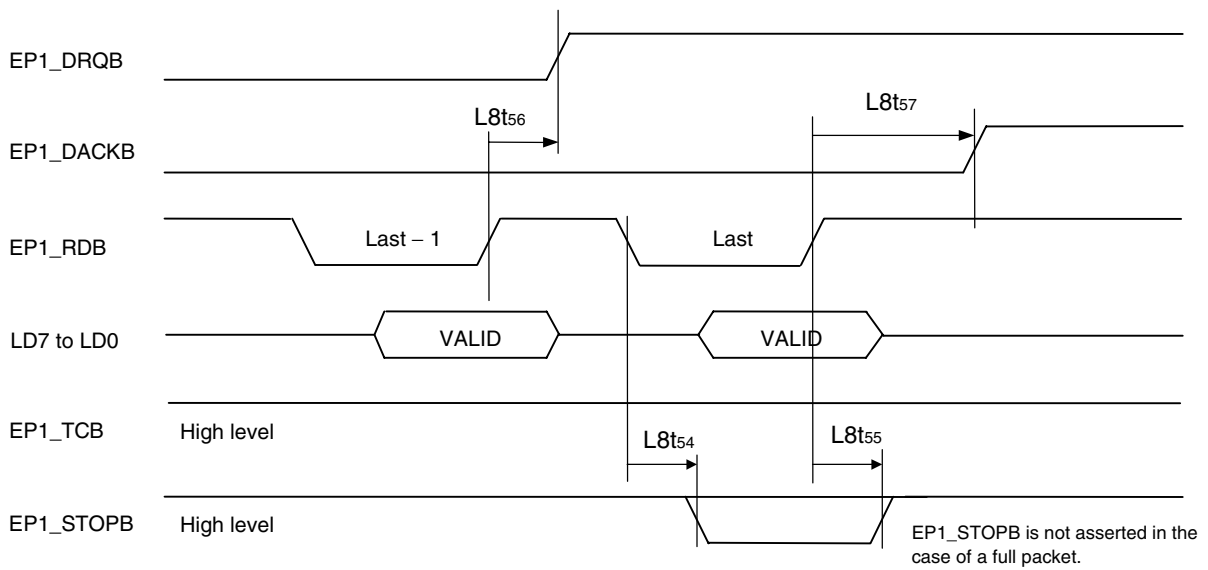

(d) External local bus 8-bit mode DMA demand write transfer timing

Symbol	Parameter	Min.	Typ.	Max.	Unit
L8T58	DMA request acknowledge setup time (EP2_WRB↓)	0		∞	ns
L8T59	DMA demand mode write transfer cycle time	72		∞	ns
L8T60	Write command width	38		∞	ns
L8T61	Write command inactive time	34		∞	ns
L8T62	Write data setup time (EP2_WRB↑)	10		∞	ns
L8T63	Write data hold time (EP2_WRB↑)	0		∞	ns
L8T66	DMA request off time (EP2_WRB↑)	-		60	ns
L8T67	DMA request acknowledge hold time (EP2_WRB↑)	0		∞	ns

- Remarks 1.** Use of EP1\_TCB is prohibited in the 8-bit external local bus mode. Clamp this signal to the inactive status.
- 2.** LD15 to 8 are undefined in the 8-bit external local bus mode (these signals are invalid when input and undefined when output).
- 3.** It is assumed that the external pin capacitance is 15 pF (data bus = 50 pF).

(Overall)

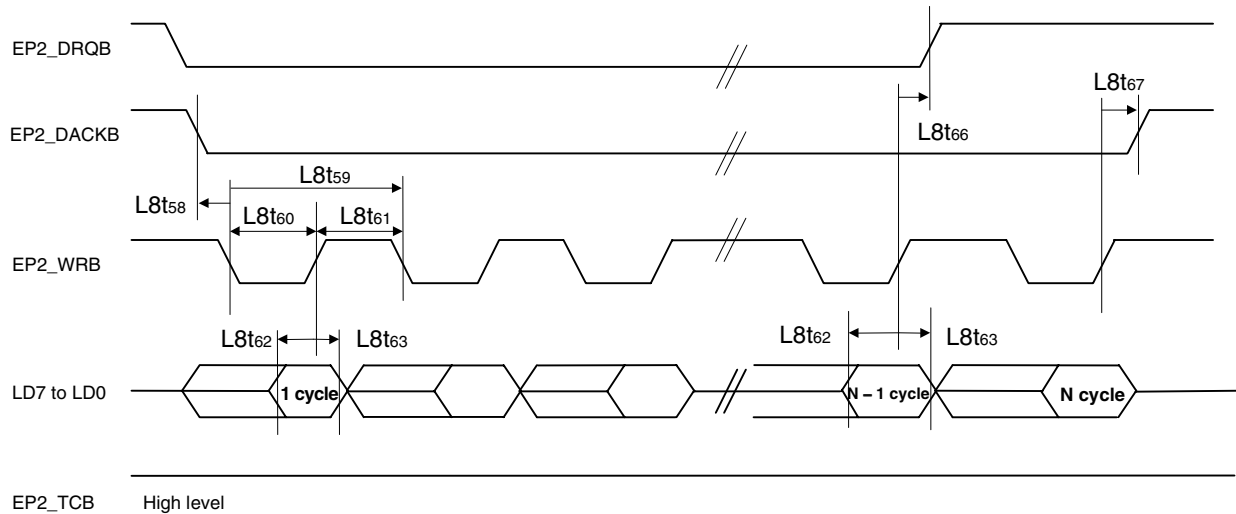

**(Start timing)**

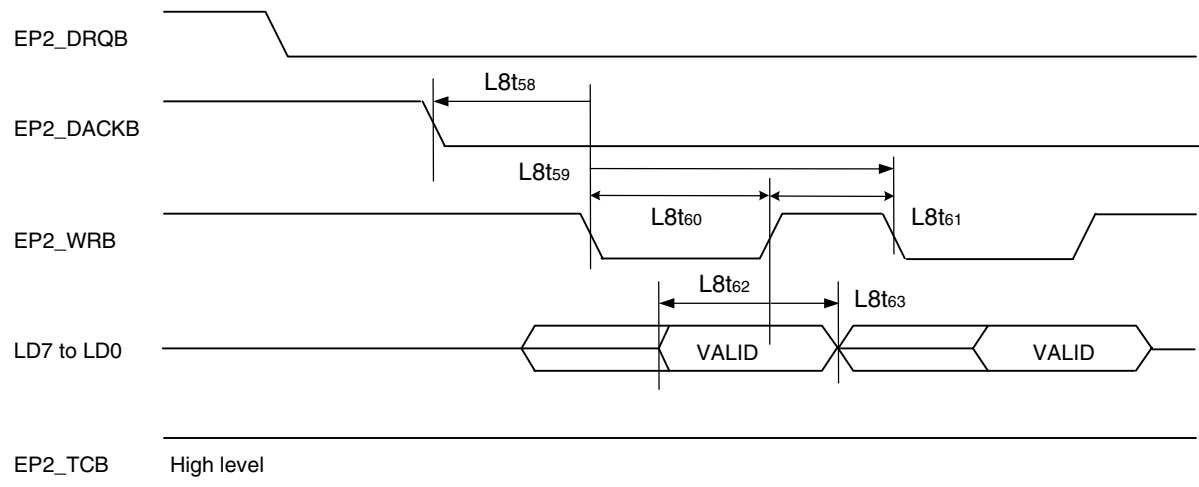

**(End timing)**

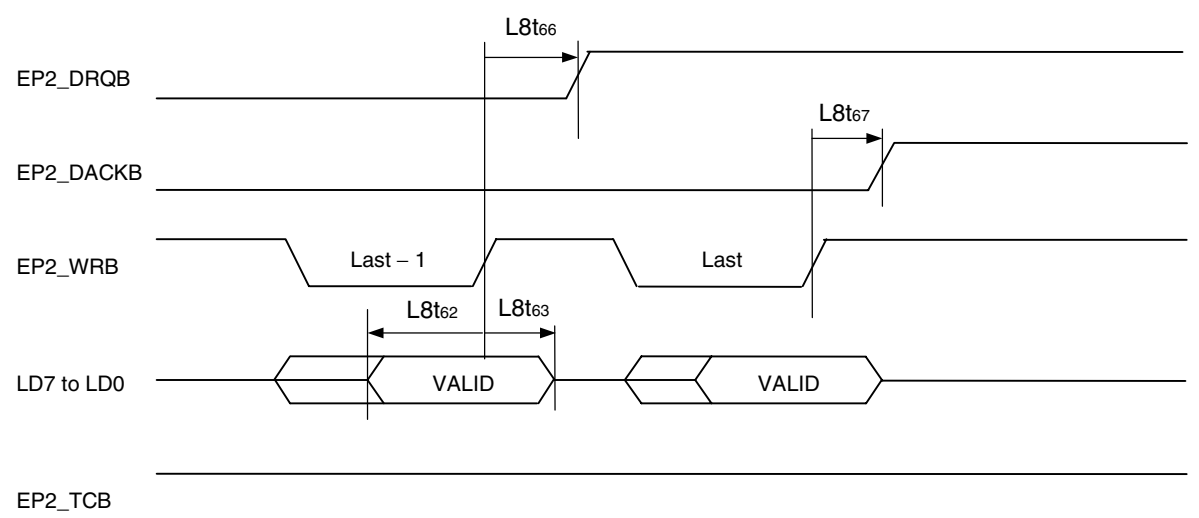

(e) External local bus 8-bit mode DMA EP1\_Read transfer vs. EP2\_Write transfer timing

Symbol	Parameter	Min.	Typ.	Max.	Unit
L8T68	EP1_RDB vs. EP2_WRB command inactive time	34		∞	ns

**Remark** It is assumed that the external pin capacitance is 15 pF (data bus = 50 pF).

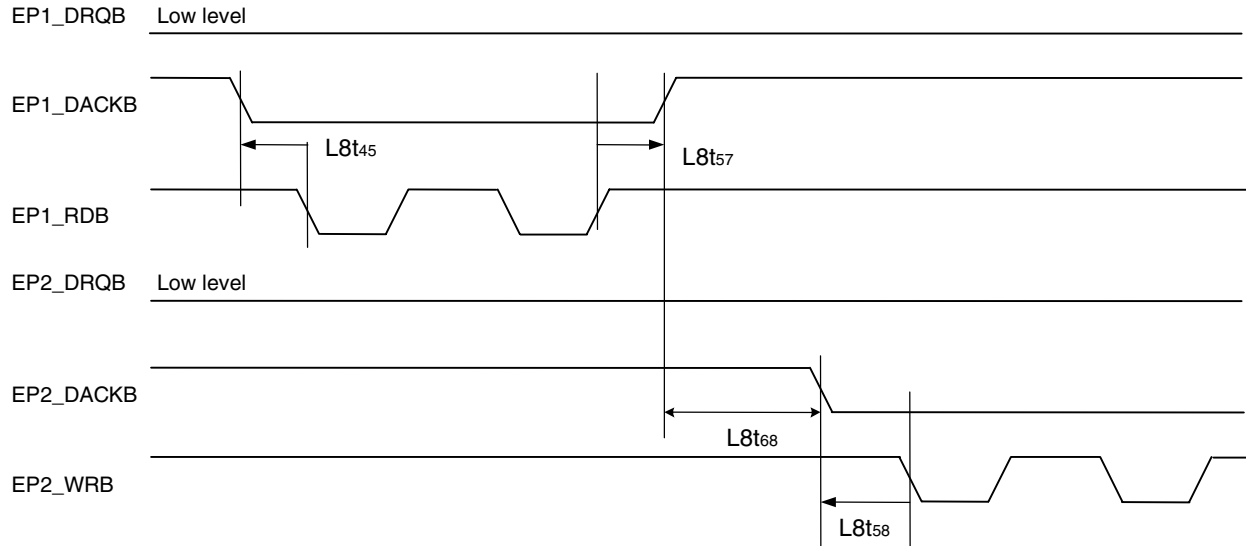



2.6.5 USB interface timing

Parameter	Symbol	Conditions	Min.	Max.	Unit
<b>Full-speed source electrical characteristics</b>					
Rise time	T <sub>FR</sub>	C <sub>L</sub> = 50 pF, R <sub>S</sub> = 36 Ω	4	20	ns
Fall time	T <sub>FF</sub>	C <sub>L</sub> = 50 pF, R <sub>S</sub> = 36 Ω	4	20	ns
Differential rise and fall time matching	T <sub>FRFM</sub>	(T <sub>FR</sub> /T <sub>FF</sub> )	90	111.11	%
Full-speed data rate for hubs and devices that are high-speed capable	T <sub>FDRATHS</sub>	Average bit rate	11.9940	12.0060	Mb/s
Frame interval	T <sub>FRAME</sub>		0.9995	1.0005	ms
Consecutive frame interval jitter	T <sub>RFI</sub>	No clock adjustment		42	ns
Source jitter total (including frequency tolerance):					
To next transition	T <sub>DJ1</sub>		-3.5	3.5	ns
For paired transitions	T <sub>DJ2</sub>		-4.0	4.0	ns
Source jitter for differential transition to SE0 transition	T <sub>FDEOP</sub>		-2	5	ns
Receiver jitter:					
To next transition	T <sub>JR1</sub>		-18.5	18.5	ns
For paired transitions	T <sub>JR2</sub>		-9	9	ns
Source SE0 interval of EOP	T <sub>FEOPT</sub>		160	175	ns
Receiver SE0 interval of EOP	T <sub>FEOPR</sub>		82		ns
Width of SE0 interval during differential transition	T <sub>FST</sub>			14	ns
<b>High-speed source electrical characteristics</b>					
Rise time (10% to 90%)	T <sub>HSR</sub>		500		ps
Fall time (10% to 90%)	T <sub>HSF</sub>		500		ps
Driver waveform requirements	See Figure 2-6				
High-speed data rate	T <sub>HSDRAT</sub>		479.760	480.240	Mb/s
Microframe interval	T <sub>HSFRAM</sub>		124.9375	125.0625	μs
Consecutive microframe interval difference	T <sub>HSRFI</sub>			4 high-speed	Bit times
Data source jitter	See Figure 2-6.				
Receiver jitter tolerance	See Figure 2-4.				

Parameter	Symbol	Conditions	Min.	Max.	Unit
<b>Device event timing</b>					
Time from internal power good to device pulling D+/D- beyond V <sub>IHZ</sub> (min.) (signaling attach)	T <sub>SIGATT</sub>			100	ms
Debounce interval provided by USB system software after attach	T <sub>ATTDB</sub>			100	ms
Inter-packet delay (for low-/full-speed)	T <sub>IPD</sub>		2		Bit times
Inter-packet delay for device response w/detachable cable for low-/full-speed	T <sub>RSPDP1</sub>			6.5	Bit times
High-speed detection start time from suspend	T <sub>SCA</sub>		2.5		μs
Sample time for suspend vs. reset	T <sub>CSR</sub>		100	875	μs
Power down under suspend	T <sub>SUS</sub>			10	ms
SUSPEND set time (SPNDOUT)	T <sub>SSP</sub>		0	-	
SUSPEND clear time (RSMOUT)	T <sub>CSP</sub>		0	-	
Reversion time from suspend to high-speed	T <sub>RHS</sub>			1.333	μs
SUSPEND setup time (RSMIN)	T <sub>SRW</sub>		0	-	
RSMIN active pulse width	T <sub>RWP</sub>		1	15	ms
Drive chirp K width	T <sub>CKO</sub>		1		ms
Finish chirp K assertion	T <sub>FCA</sub>			7	ms
Start sequencing chirp K-J-K-J-K-J	T <sub>SSC</sub>			100	μs
Finish sequencing chirp K-J	T <sub>FSC</sub>		-500	-100	μs
Detect sequencing chirp K-J width	T <sub>CSI</sub>		2.5		μs
Sample time for sequencing chirp	T <sub>SCS</sub>		1.0	2.5	ms
Reversion time to high-speed	T <sub>RHA</sub>			500	μs
High-speed detection start time	T <sub>HDS</sub>		2.5	3000	μs
Reset completed time	T <sub>DRS</sub>		10		ms

Figure 2-6. Transmit Waveform for Transceiver at D+/D-

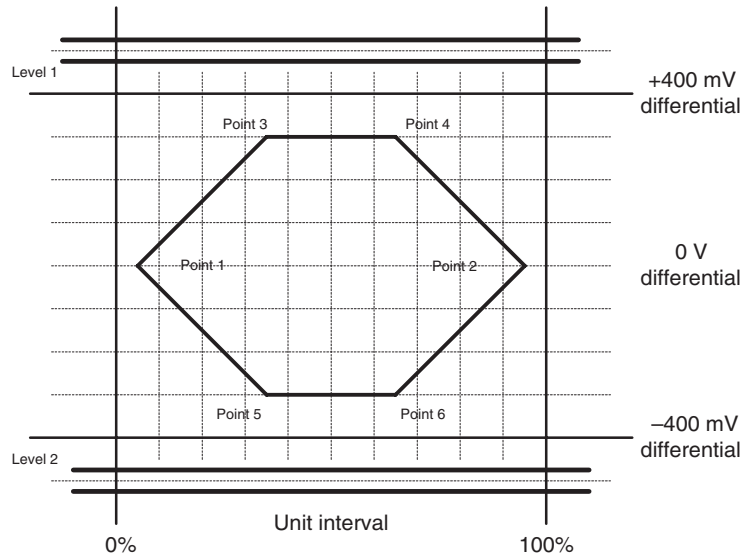
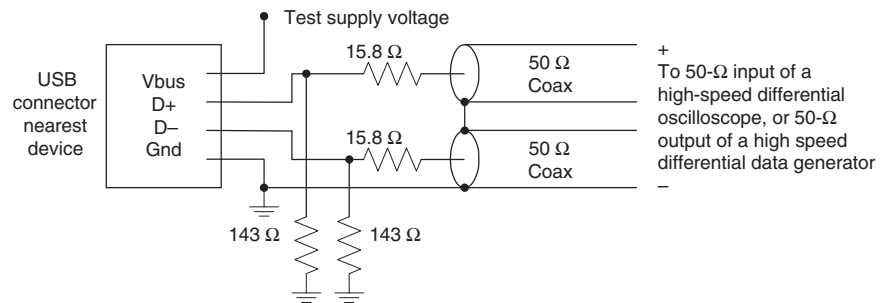
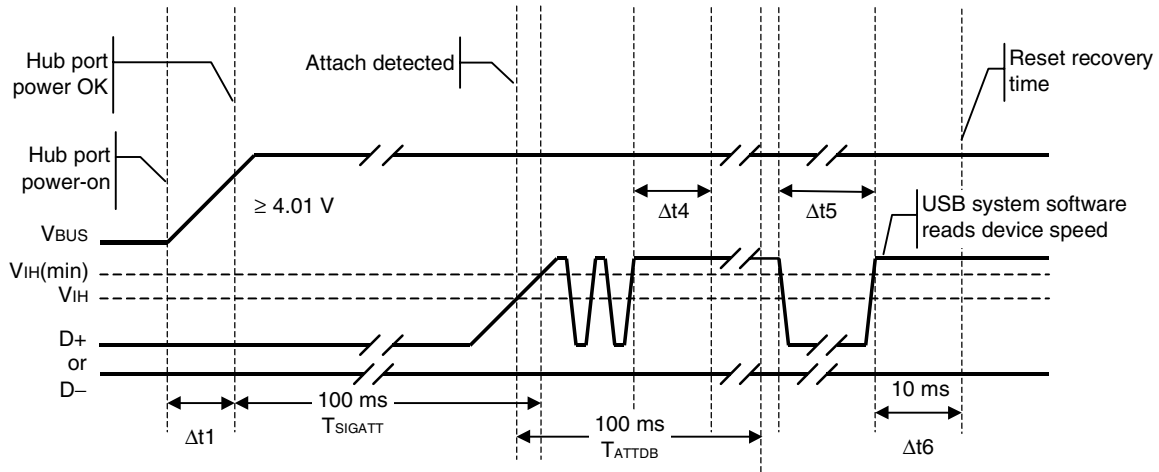

Figure 2-7. Transmitter Measurement Fixtures



(1) Power-on and connection events

Figure 2-8. Power-on and Connection Event Timing



(2) USB signals

Figure 2-9. USB Differential Data Jitter for Full-Speed

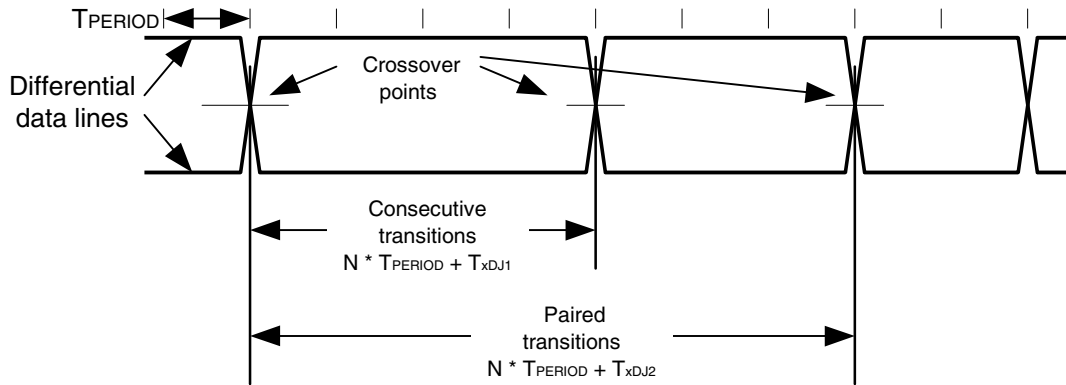

Figure 2-10. USB Differential-to-EOP Transition Skew and EOP Width for Full-Speed

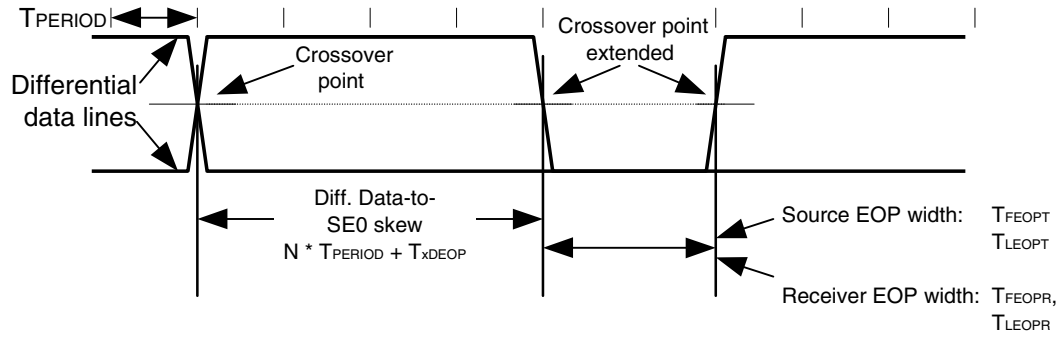
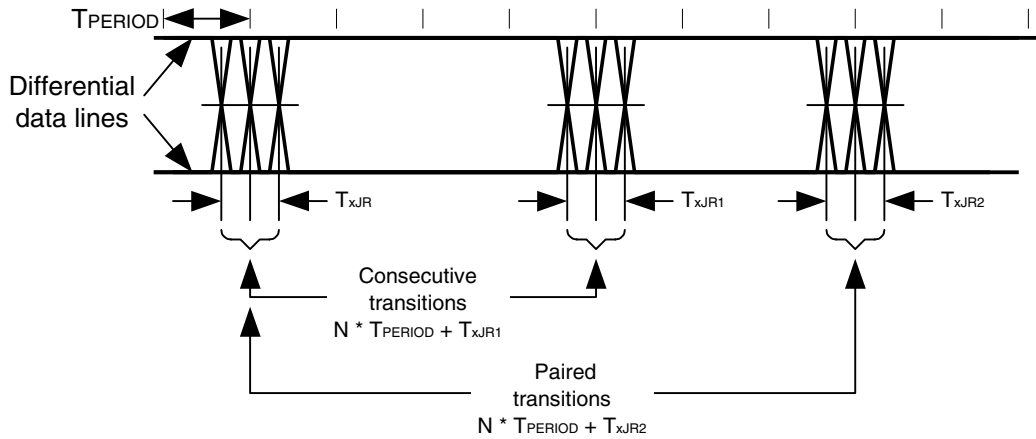

Figure 2-11. USB Receiver Jitter Tolerance for Full-Speed



**(3) USB connection sequence on USB1.1 bus**

The PHY core implemented on the μPD720122 automatically determines the Up port.

Check the SP\_MODE bit (SP\_MODE) of the Int Status 2 register after an EPC2\_STG bus reset interrupt has occurred to determine whether the USB is connected to FS or HS.

Figure 2-12. USB Connection Sequence on USB 1.1 Bus

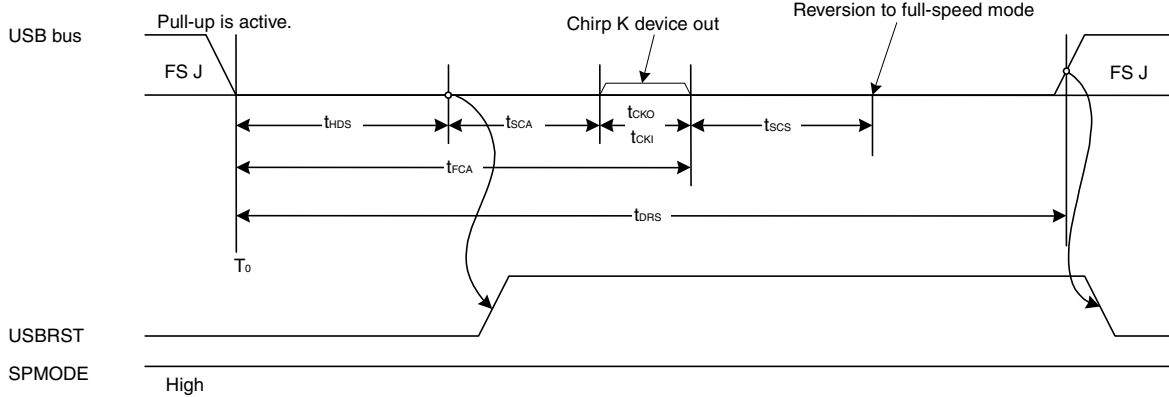

(4) USB connection sequence on USB 2.0 bus

Figure 2-13. USB Connection Sequence on USB 2.0 Bus

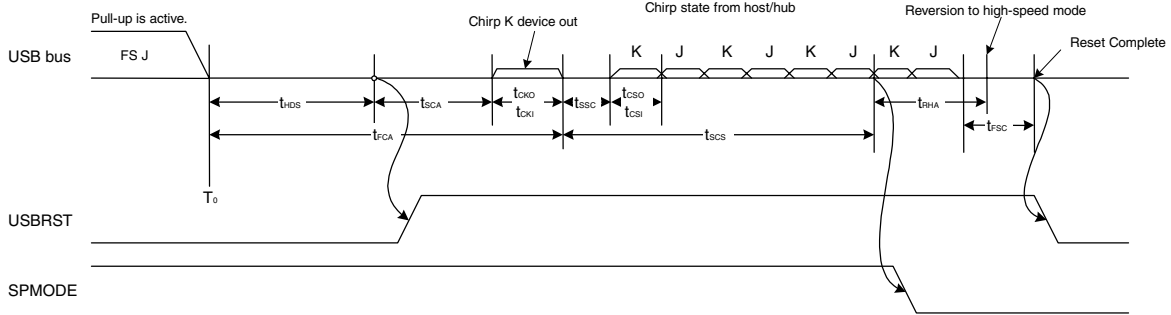

(5) Bus reset sequence (1)

The bus reset sequence when connected to a USB 1.1 bus is shown below.

Figure 2-14. Bus Reset Sequence (1)

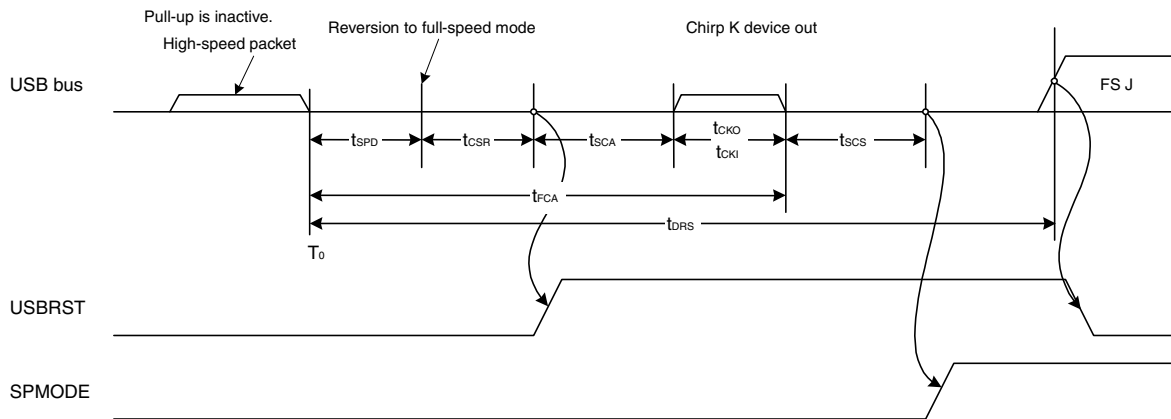

(6) Bus reset sequence (2)

The bus reset sequence when connected to a USB 2.0 bus is shown below.

Figure 2-15. Bus Reset Sequence (2)

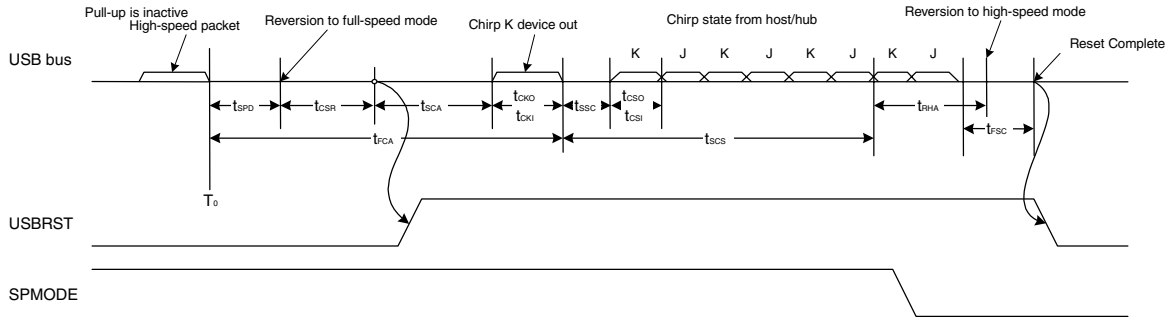



(7) USB reset from suspend state (1)

Figure 2-16. USB Reset from Suspend State (1)

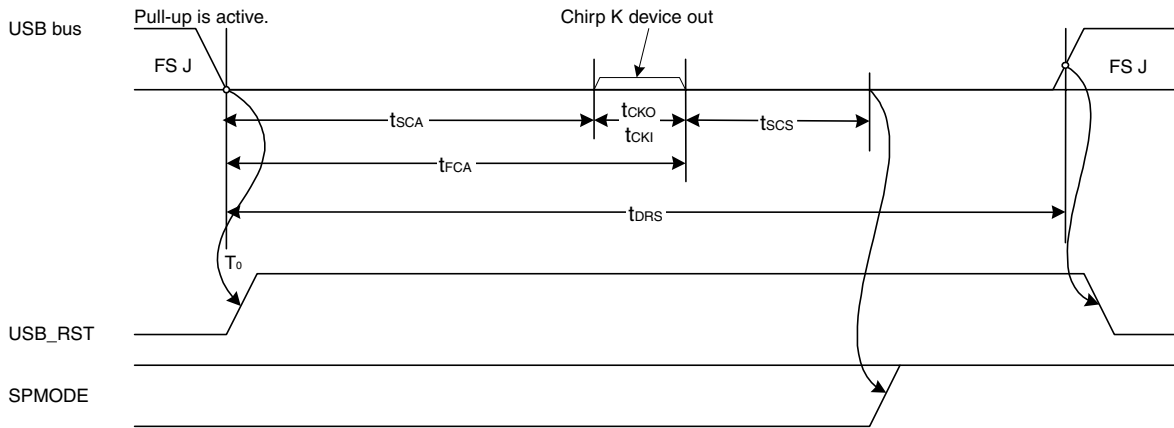

(8) USB reset from suspend state (2)

Figure 2-17. USB Reset from Suspend State (2)

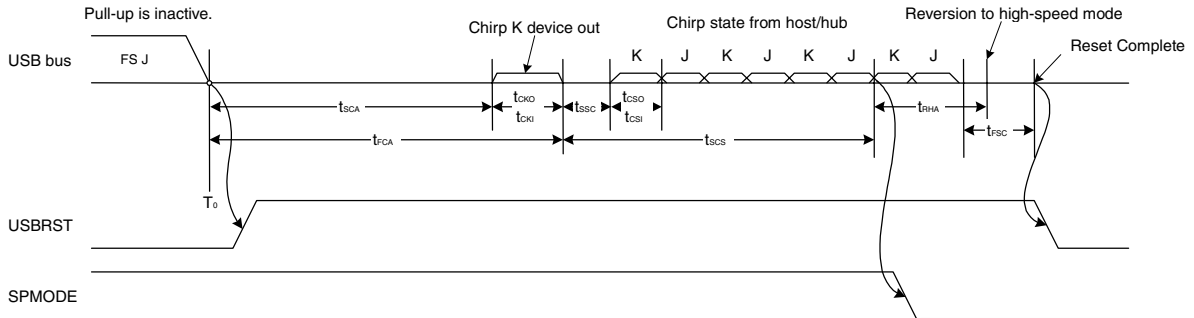

(9) Suspend and resume on USB1.1 bus

Figure 2-18. Suspend and Resume on USB 1.1 Bus

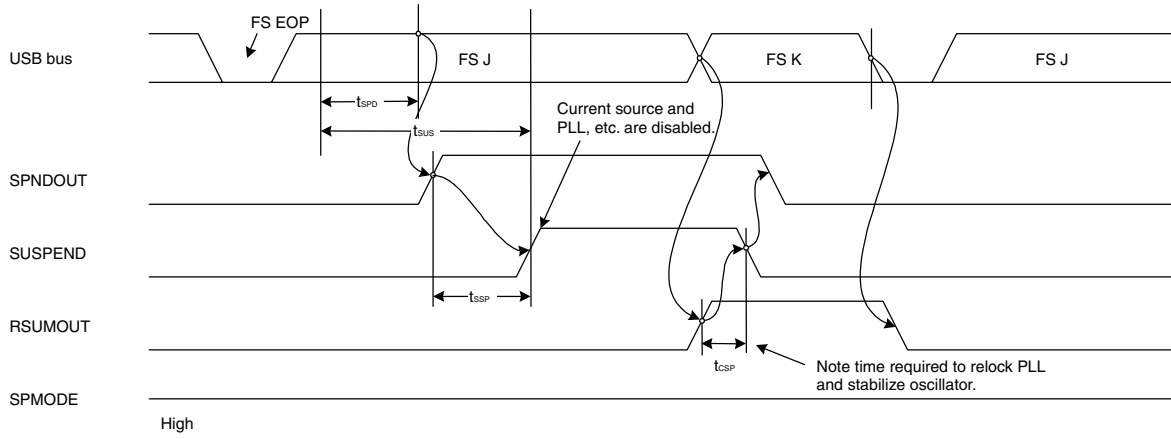

(10) Suspend and resume on USB2.0 bus

Figure 2-19. Suspend and Resume on USB 2.0 Bus

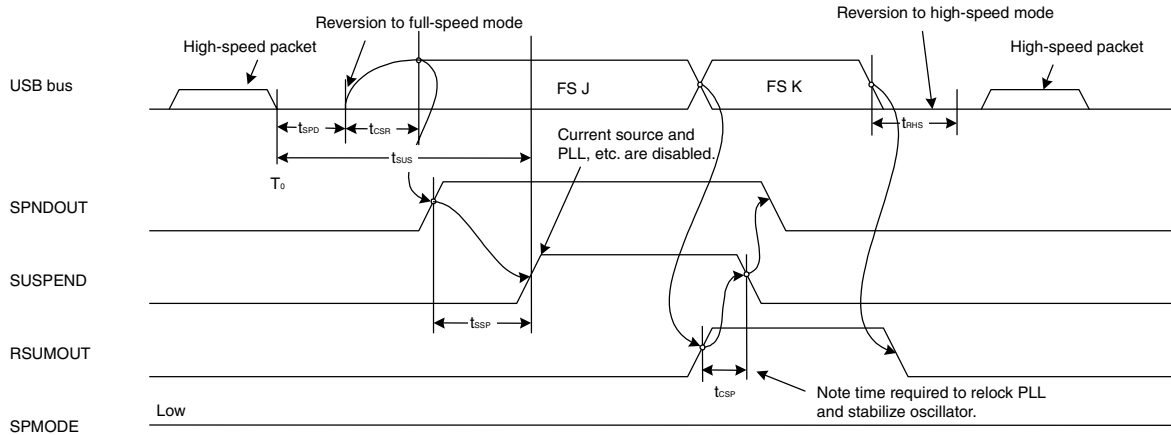

(11) Remote wakeup on USB1.1

Figure 2-20. Remote Wakeup on USB 1.1

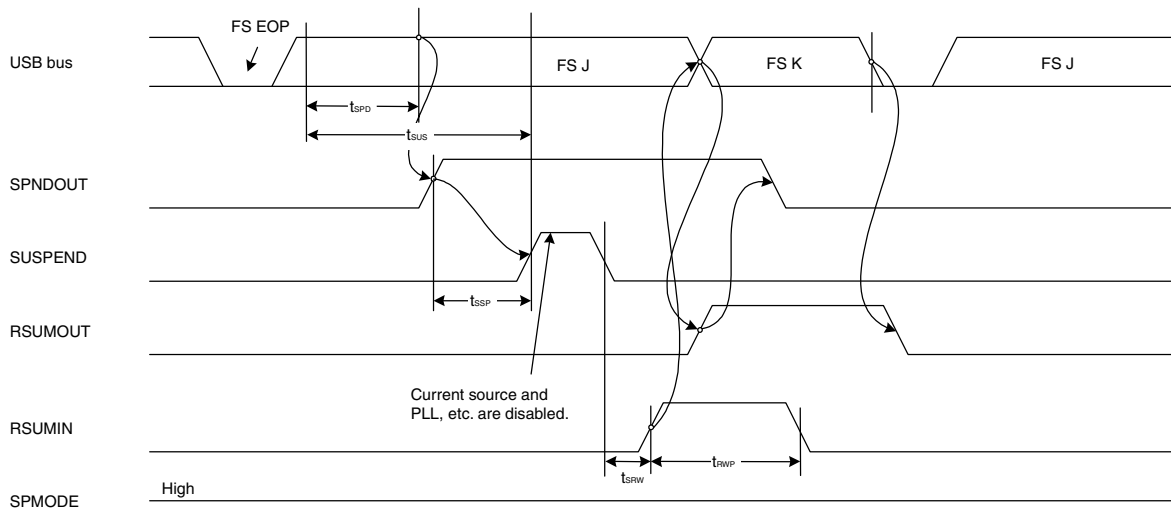

(12) Remote wakeup on USB2.0

Figure 2-21. Remote Wakeup on USB 2.0

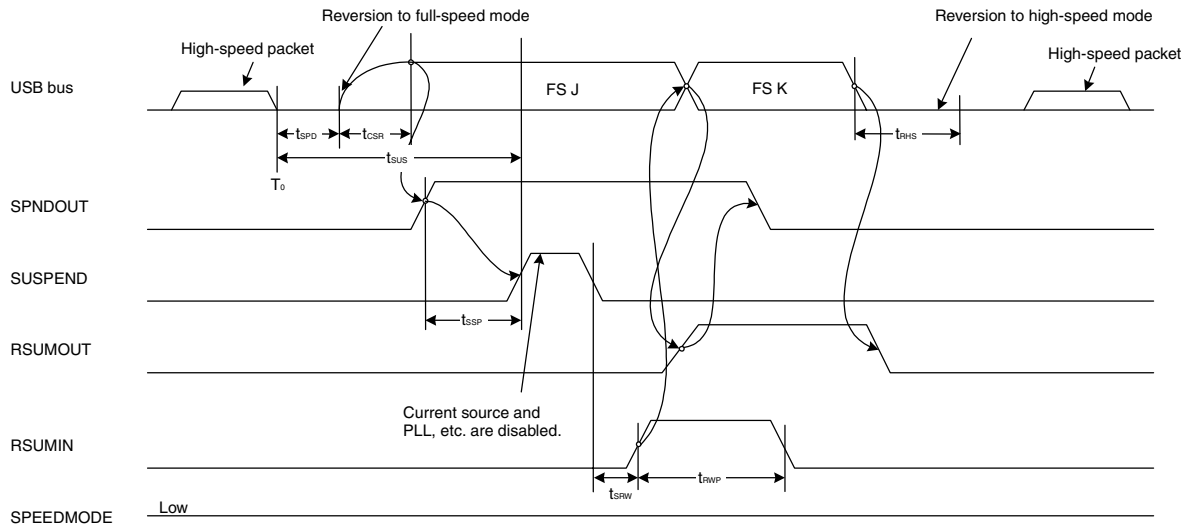

3. PACKAGE DRAWING

★ 100-PIN PLASTIC TQFP (FINE PITCH) (14x14)

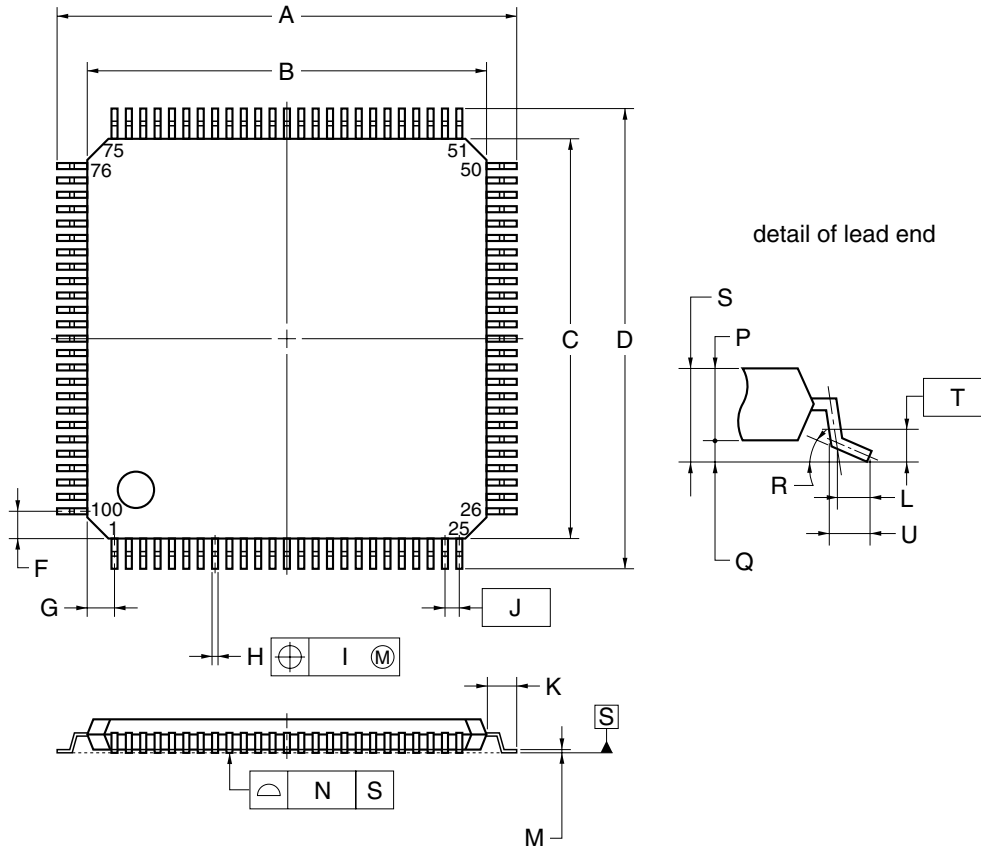

**NOTE**  
 Each lead centerline is located within 0.08 mm of its true position (T.P.) at maximum material condition.

ITEM	MILLIMETERS
A	16.0±0.2
B	14.0±0.2
C	14.0±0.2
D	16.0±0.2
F	1.0
G	1.0
H	0.22±0.05
I	0.08
J	0.5 (T.P.)
K	1.0±0.2
L	0.5
M	0.17 <sup>+0.03</sup> <sub>-0.07</sub>
N	0.08
P	1.0
Q	0.1±0.05
R	3° <sup>+4°</sup> <sub>-3°</sub>
S	1.1±0.1
T	0.25
U	0.6±0.15

P100GC-50-9EU

109-PIN PLASTIC FBGA (11x11)

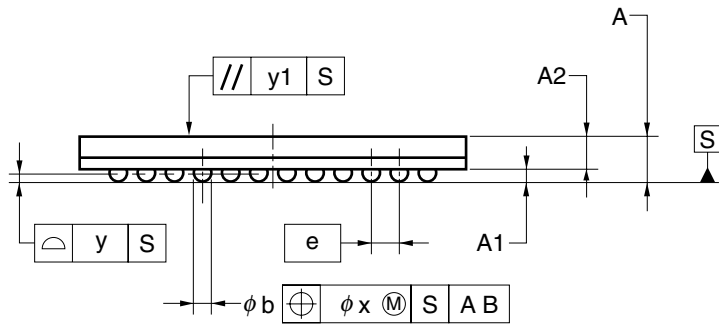
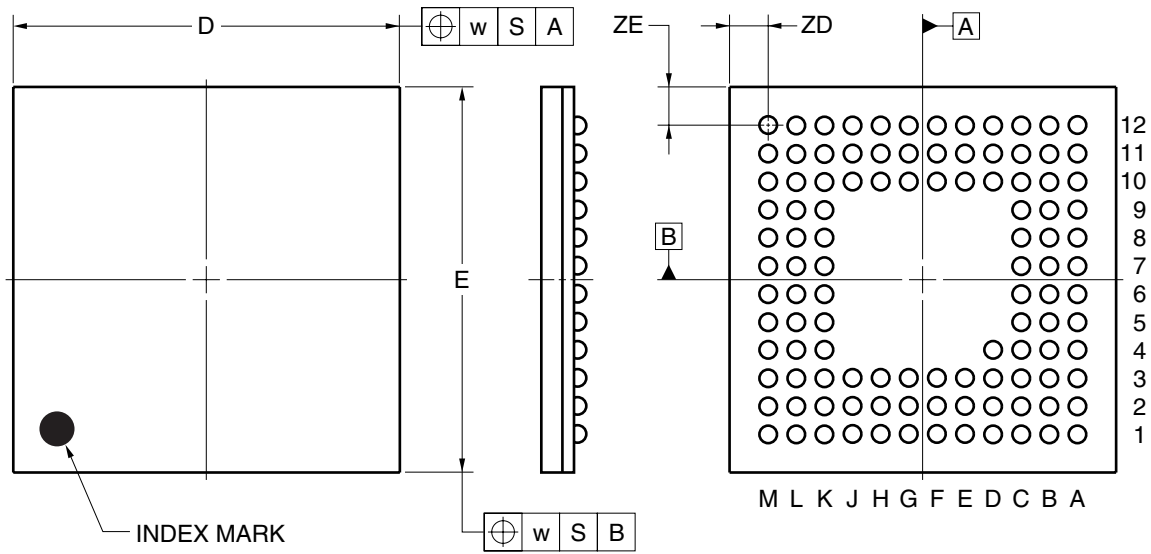

(UNIT:mm)

ITEM	DIMENSIONS
D	11.00±0.10
E	11.00±0.10
w	0.20
A	1.28±0.10
A1	0.35±0.06
A2	0.93
e	0.80
b	0.50 <sup>+0.05</sup> <sub>-0.10</sub>
x	0.08
y	0.10
y1	0.20
ZD	1.10
ZE	1.10

P109F1-80-DN2

**4. RECOMMENDED SOLDERING CONDITIONS**

The μPD720122 should be soldered and mounted under the following recommended conditions.

For soldering methods and conditions other than those recommended below, contact your NEC Electronics sales representative.

For technical information, see the following website.

Semiconductor Device Mount Manual (<http://www.necel.com/pkg/en/mount/index.html>)

**• μ PD720122GC-9EU : 100-pin plastic TQFP (Fine pitch) (14 × 14)**

Soldering Method	Soldering Conditions	Symbol
Infrared reflow	Package peak temperature: 235°C, Time: 30 seconds max. (at 210°C or higher), Count: Two times or less Exposure limit: 3 days <sup>Note</sup> (after that, prebake at 125°C for 10 hours)	IR35-103-2
Partial heating	Pin temperature: 300°C max., Time: 3 seconds max. (per pin row)	–

**Note** After opening the dry pack, store it at 25°C or less and 65% RH or less for the allowable storage period.

**• μ PD720122F1-GN2 : 109-pin plastic FBGA (11 × 11)**

Soldering Method	Soldering Conditions	Symbol
Infrared reflow	Package peak temperature: 235°C, Time: 30 seconds max. (at 210°C or higher), Count: Three times or less Exposure limit: 3 days <sup>Note</sup> (after that, prebake at 125°C for 10 hours)	IR35-103-3
Partial heating	Pin temperature: 300°C max., Time: 3 seconds max. (per pin row)	–

**Note** After opening the dry pack, store it at 25°C or less and 65% RH or less for the allowable storage period.

[MEMO]



**NOTES FOR CMOS DEVICES****① PRECAUTION AGAINST ESD FOR SEMICONDUCTORS**

Note:

Strong electric field, when exposed to a MOS device, can cause destruction of the gate oxide and ultimately degrade the device operation. Steps must be taken to stop generation of static electricity as much as possible, and quickly dissipate it once, when it has occurred. Environmental control must be adequate. When it is dry, humidifier should be used. It is recommended to avoid using insulators that easily build static electricity. Semiconductor devices must be stored and transported in an anti-static container, static shielding bag or conductive material. All test and measurement tools including work bench and floor should be grounded. The operator should be grounded using wrist strap. Semiconductor devices must not be touched with bare hands. Similar precautions need to be taken for PW boards with semiconductor devices on it.

**② HANDLING OF UNUSED INPUT PINS FOR CMOS**

Note:

No connection for CMOS device inputs can be cause of malfunction. If no connection is provided to the input pins, it is possible that an internal input level may be generated due to noise, etc., hence causing malfunction. CMOS devices behave differently than Bipolar or NMOS devices. Input levels of CMOS devices must be fixed high or low by using a pull-up or pull-down circuitry. Each unused pin should be connected to V<sub>DD</sub> or GND with a resistor, if it is considered to have a possibility of being an output pin. All handling related to the unused pins must be judged device by device and related specifications governing the devices.

**③ STATUS BEFORE INITIALIZATION OF MOS DEVICES**

Note:

Power-on does not necessarily define initial status of MOS device. Production process of MOS does not define the initial operation status of the device. Immediately after the power source is turned ON, the devices with reset function have not yet been initialized. Hence, power-on does not guarantee out-pin levels, I/O settings or contents of registers. Device is not initialized until the reset signal is received. Reset operation must be executed immediately after power-on for devices having reset function.

**EEPROM is a trademark of NEC Electronics Corporation.**

**USB logo is a trademark of USB Implementers Forum, Inc.**

- **The information in this document is current as of June, 2003. The information is subject to change without notice. For actual design-in, refer to the latest publications of NEC Electronics data sheets or data books, etc., for the most up-to-date specifications of NEC Electronics products. Not all products and/or types are available in every country. Please check with an NEC Electronics sales representative for availability and additional information.**
- No part of this document may be copied or reproduced in any form or by any means without the prior written consent of NEC Electronics. NEC Electronics assumes no responsibility for any errors that may appear in this document.
- NEC Electronics does not assume any liability for infringement of patents, copyrights or other intellectual property rights of third parties by or arising from the use of NEC Electronics products listed in this document or any other liability arising from the use of such products. No license, express, implied or otherwise, is granted under any patents, copyrights or other intellectual property rights of NEC Electronics or others.
- Descriptions of circuits, software and other related information in this document are provided for illustrative purposes in semiconductor product operation and application examples. The incorporation of these circuits, software and information in the design of a customer's equipment shall be done under the full responsibility of the customer. NEC Electronics assumes no responsibility for any losses incurred by customers or third parties arising from the use of these circuits, software and information.
- While NEC Electronics endeavors to enhance the quality, reliability and safety of NEC Electronics products, customers agree and acknowledge that the possibility of defects thereof cannot be eliminated entirely. To minimize risks of damage to property or injury (including death) to persons arising from defects in NEC Electronics products, customers must incorporate sufficient safety measures in their design, such as redundancy, fire-containment and anti-failure features.
- NEC Electronics products are classified into the following three quality grades: "Standard", "Special" and "Specific".  
The "Specific" quality grade applies only to NEC Electronics products developed based on a customer-designated "quality assurance program" for a specific application. The recommended applications of an NEC Electronics product depend on its quality grade, as indicated below. Customers must check the quality grade of each NEC Electronics product before using it in a particular application.
  - "Standard": Computers, office equipment, communications equipment, test and measurement equipment, audio and visual equipment, home electronic appliances, machine tools, personal electronic equipment and industrial robots.
  - "Special": Transportation equipment (automobiles, trains, ships, etc.), traffic control systems, anti-disaster systems, anti-crime systems, safety equipment and medical equipment (not specifically designed for life support).
  - "Specific": Aircraft, aerospace equipment, submersible repeaters, nuclear reactor control systems, life support systems and medical equipment for life support, etc.

The quality grade of NEC Electronics products is "Standard" unless otherwise expressly specified in NEC Electronics data sheets or data books, etc. If customers wish to use NEC Electronics products in applications not intended by NEC Electronics, they must contact an NEC Electronics sales representative in advance to determine NEC Electronics' willingness to support a given application.

(Note)

- (1) "NEC Electronics" as used in this statement means NEC Electronics Corporation and also includes its majority-owned subsidiaries.
- (2) "NEC Electronics products" means any product developed or manufactured by or for NEC Electronics (as defined above).