

# MOS INTEGRATED CIRCUIT

# $\mu$ PD77110, 77111, 77112

## 16-BIT FIXED-POINT DIGITAL SIGNAL PROCESSORS

### DESCRIPTION

The  $\mu$ PD77110, 77111, and 77112 are 16-bit fixed-point digital signal processors (DSPs).

Compared with the  $\mu$ PD77016 family, these DSPs have improved power consumption and are ideal for battery-powered mobile terminals such as PDAs and cellular phones.

Both mask ROM and RAM models are available.

For details of the functions of these DSPs, refer to the following User's Manuals:

$\mu$ PD77111 Family User's Manual : To be available soon

$\mu$ PD7701X Family User's Manual - Instructions: U13116E

### FEATURES

- Instruction cycle (operating clock)
  - $\mu$ PD77110: 15.3 ns MIN (65 MHz MAX)  
13.3 ns MIN (75 MHz MAX) (Operating voltage and ambient temperature are limited.)
  - $\mu$ PD77111: 13.3 ns MIN (75 MHz MAX)
  - $\mu$ PD77112: 13.3 ns MIN (75 MHz MAX)
- Memory
- Internal instruction memory
  - $\mu$ PD77110: RAM 35.5K words  $\times$  32 bits
  - $\mu$ PD77111: RAM 1K words  $\times$  32 bits  
Mask ROM 31.75K words  $\times$  32 bits
  - $\mu$ PD77112: RAM 1K words  $\times$  32 bits  
Mask ROM 31.75K words  $\times$  32 bits
- Data memory
  - $\mu$ PD77110: RAM 24K words  $\times$  16 bits  $\times$  2 banks  
External memory space 32K words  $\times$  16 bits  $\times$  2 banks
  - $\mu$ PD77111: RAM 3K words  $\times$  16 bits  $\times$  2 banks  
Mask ROM 16K words  $\times$  16 bits  $\times$  2 banks
  - $\mu$ PD77112: RAM 3K words  $\times$  16 bits  $\times$  2 banks  
Mask ROM 16K words  $\times$  16 bits  $\times$  2 banks  
External memory space 16K words  $\times$  16 bits  $\times$  2 banks

The information in this document is subject to change without notice. Before using this document, please confirm that this is the latest version.

Not all devices/types available in every country. Please check with local NEC representative for availability and additional information.

## ORDERING INFORMATION

Part Number	Package
$\mu$ PD77110GC-9EU	100-pin plastic TQFP (fine pitch) (14 × 14 mm)
$\mu$ PD77111GK-xxx-9EU	80-pin plastic TQFP (fine pitch) (12 × 12 mm)
$\mu$ PD77111F1-xxx-CN1	80-pin plastic fine-pitch BGA (9 × 9 mm)
$\mu$ PD77112GC-xxx-9EU	100-pin plastic TQFP (fine pitch) (14 × 14 mm)

**Remark** xxx indicates ROM code suffix.

BLOCK DIAGRAM

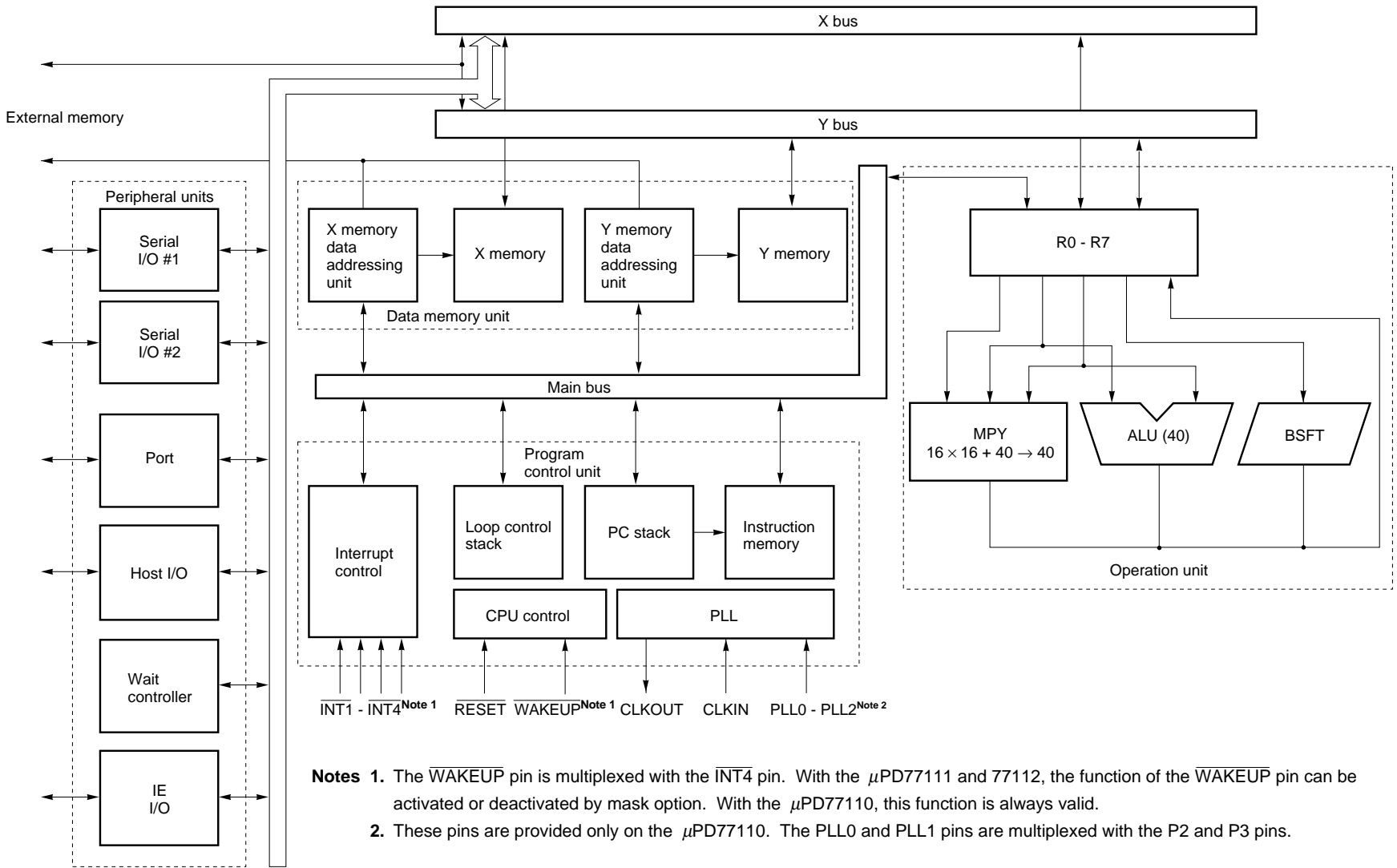

- Notes**
1. The  $\overline{\text{WAKEUP}}$  pin is multiplexed with the  $\overline{\text{INT4}}$  pin. With the  $\mu\text{PD77111}$  and  $77112$ , the function of the  $\overline{\text{WAKEUP}}$  pin can be activated or deactivated by mask option. With the  $\mu\text{PD77110}$ , this function is always valid.
  2. These pins are provided only on the  $\mu\text{PD77110}$ . The PLL0 and PLL1 pins are multiplexed with the P2 and P3 pins.

PIN CONFIGURATION

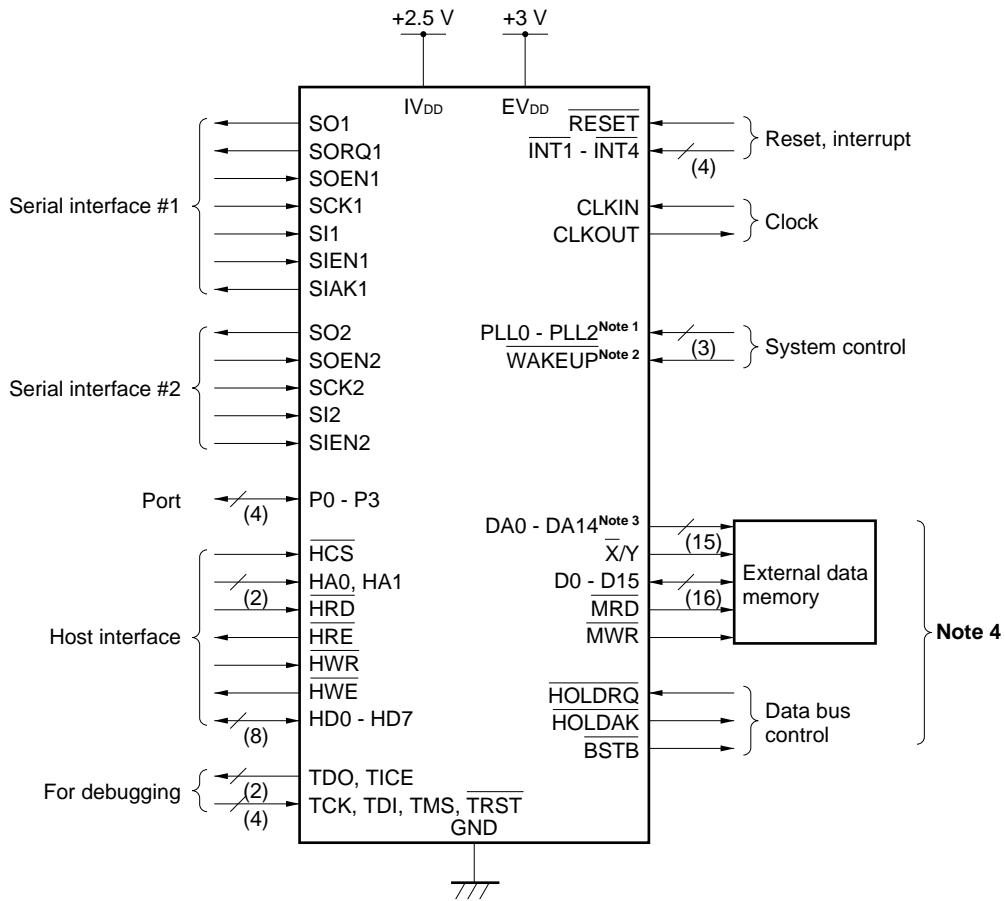

- Notes**
1. These pins are provided only on the μPD77110.
  2. With the μPD77111 and 77112, the function of this pin can be activated or deactivated by mask option. With the μPD77110, this function is always valid.
  3. DA14 is not provided on the μPD77112.
  4. An external data memory interface is not provided on the μPD77111.

★ DSP FUNCTION LIST

Item		μPD77016	μPD77018A	μPD77019	μPD77019-013	μPD77110	μPD77111	μPD77112	μPD77113	μPD77114	
Memory space (words × bits)	Internal instruction RAM	1.5K × 32	256 × 32	4K × 32		35.5K × 32	1K × 32		3.5K × 32		
	Internal instruction ROM	None	24K × 32		None		31.75K × 32		48K × 32		
	Data RAM (X/Y memory)	2K × 16 each	3K × 16 each			24K × 16 each	3K × 16 each		16K × 16 each		
	Data ROM (X/Y memory)	None	12K × 16 each		None		16K × 16 each		32K × 16 each		
	External instruction memory	48K × 32	None								
	External data memory (X/Y memory)	48K × 16 each	16K × 16 each			32K × 16 each	None	16K × 16 each	None	8K × 16 each	
Instruction cycle (at maximum speed)	30 ns (33 MHz)	16.6 ns (60 MHz)			15.3 ns (65 MHz)	13.3 ns (75 MHz)					
Multiple	–	×1, 2, 3, 4, 8 (mask option)		Fixed to ×4	Integer of ×1 to 8 (external pin)	Integer of ×1 to 16 (mask option)					
Serial interface (two channels)	Channels 1 and 2 have same function.	Channel 1 has same function as μPD77016. Channel 2 does not have SORQ2 and SIAK2 pins (for connection of codec).									
Supply voltage	5 V	3 V				DSP core: 2.5 V I/O pins : 3 V					
Package	160-pin QFP	100-pin TQFP 116-pin BGA	100-pin TQFP			80-pin TQFP 80-pin FBGA	100-pin TQFP	80-pin FBGA	100-pin TQFP		

PIN CONFIGURATION

100-pin plastic TQFP (fine-pitch) (14 × 14 mm) (Top View)

μPD77110GC-9EU

μPD77112GC-xxx-9EU

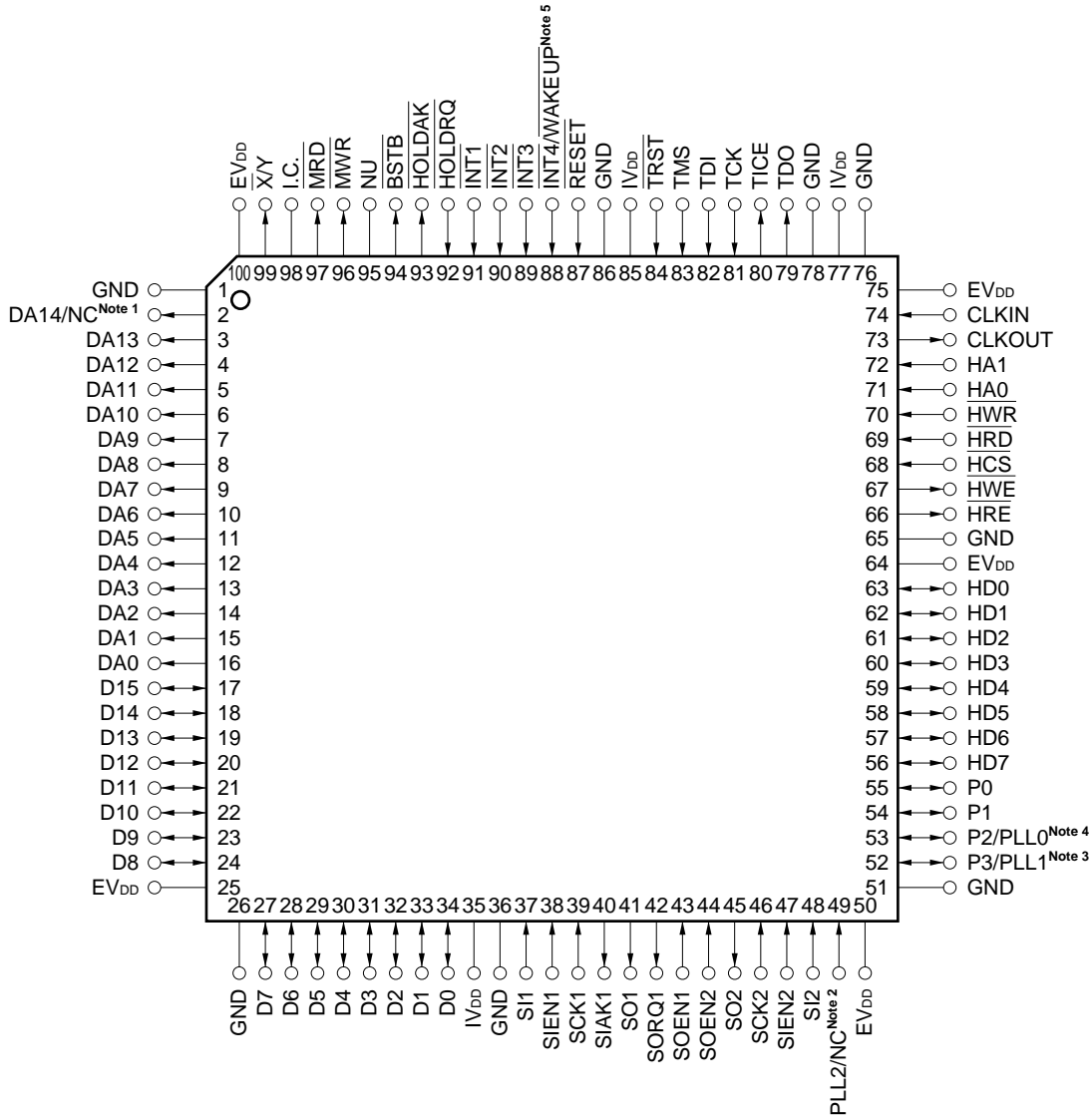

- Notes**
1. DA14 with μPD77110, NC with μPD77112
  2. PLL2 with μPD77110, NC with μPD77112
  3. P3 only for μPD77112
  4. P2 only for μPD77112
  5. With the μPD77112, the function of the WAKEUP pin can be activated or deactivated by a mask option.

Pin No.	Pin Name	Pin No.	Pin Name	Pin No.	Pin Name	Pin No.	Pin Name
1	GND	26	GND	51	GND	76	GND
2	DA14/NC	27	D7	52	P3/PLL1	77	IV <sub>DD</sub>
3	DA13	28	D6	53	P2/PLL0	78	GND
4	DA12	29	D5	54	P1	79	TDO
5	DA11	30	D4	55	P0	80	TICE
6	DA10	31	D3	56	HD7	81	TCK
7	DA9	32	D2	57	HD6	82	TD1
8	DA8	33	D1	58	HD5	83	TMS
9	DA7	34	D0	59	HD4	84	TR <sub>ST</sub>
10	DA6	35	IV <sub>DD</sub>	60	HD3	85	IV <sub>DD</sub>
11	DA5	36	GND	61	HD2	86	GND
12	DA4	37	SI1	62	HD1	87	RESET
13	DA3	38	SIEN1	63	HD0	88	INT4/WAKEUP
14	DA2	39	SCK1	64	EV <sub>DD</sub>	89	INT3
15	DA1	40	SIK1	65	GND	90	INT2
16	DA0	41	SO1	66	HRE	91	INT1
17	D15	42	SORQ1	67	HWE	92	HOLD <sub>RQ</sub>
18	D14	43	SOEN1	68	HCS	93	HOLD <sub>AK</sub>
19	D13	44	SOEN2	69	HRD	94	BST <sub>B</sub>
20	D12	45	SO2	70	HWR	95	NU
21	D11	46	SCK2	71	HA0	96	MWR
22	D10	47	SIEN2	72	HA1	97	MRD
23	D9	48	SI2	73	CLKOUT	98	I.C.
24	D8	49	PLL2/NC	74	CLKIN	99	X/Y
25	EV <sub>DD</sub>	50	EV <sub>DD</sub>	75	EV <sub>DD</sub>	100	EV <sub>DD</sub>

80-pin plastic TQFP (fine-pitch) (12 × 12 mm) (Top view)

μPD77111GK-xxx-9EU

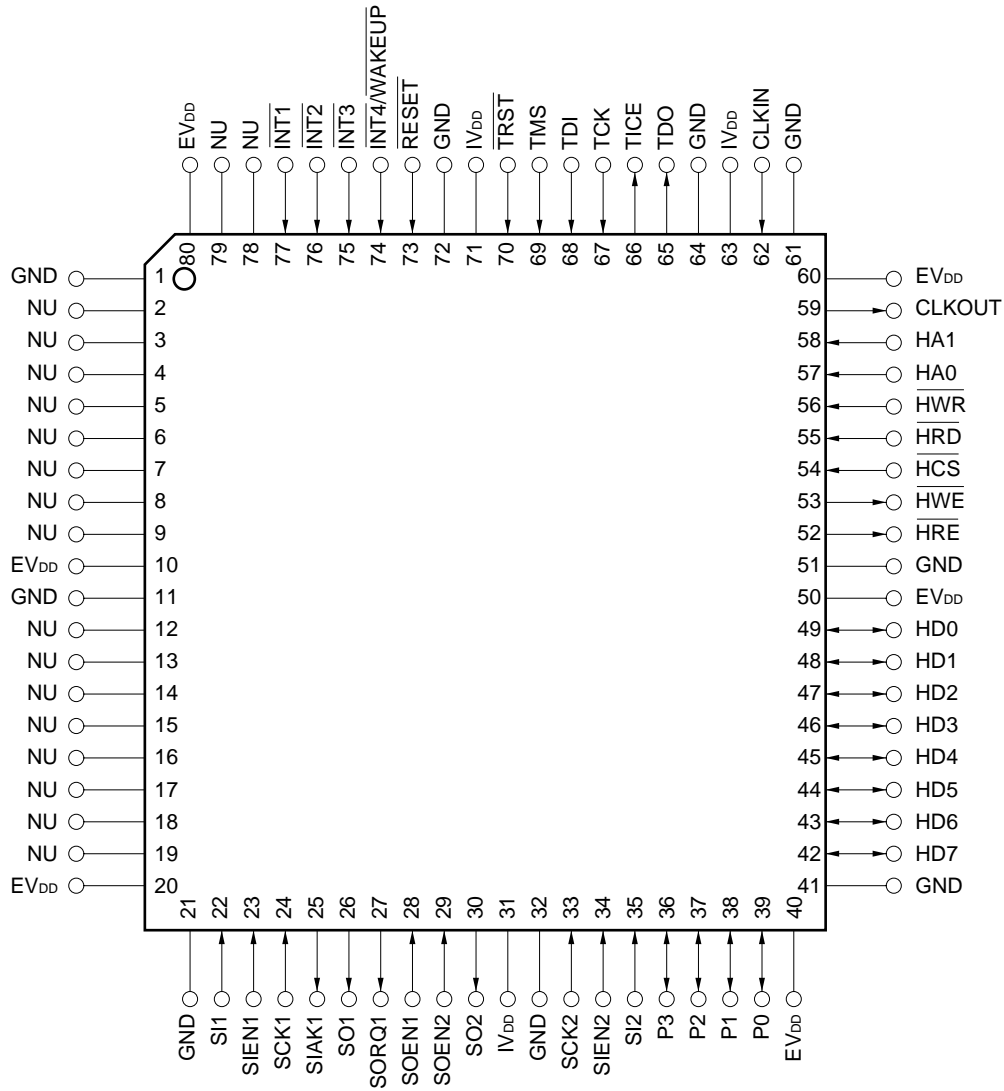



Pin No.	Pin Name	Pin No.	Pin Name	Pin No.	Pin Name	Pin No.	Pin Name
1	GND	21	GND	41	GND	61	GND
2	NU	22	SI1	42	HD7	62	CLKIN
3	NU	23	SIEN1	43	HD6	63	IV <sub>DD</sub>
4	NU	24	SCK1	44	HD5	64	GND
5	NU	25	SIK1	45	HD4	65	TDO
6	NU	26	SO1	46	HD3	66	TICE
7	NU	27	SORQ1	47	HD2	67	TCK
8	NU	28	SOEN1	48	HD1	68	TDI
9	NU	29	SOEN2	49	HD0	69	TMS
10	EV <sub>DD</sub>	30	SO2	50	EV <sub>DD</sub>	70	$\overline{\text{TRST}}$
11	GND	31	IV <sub>DD</sub>	51	GND	71	IV <sub>DD</sub>
12	NU	32	GND	52	$\overline{\text{HRE}}$	72	GND
13	NU	33	SCK2	53	$\overline{\text{HWE}}$	73	$\overline{\text{RESET}}$
14	NU	34	SIEN2	54	$\overline{\text{HCS}}$	74	$\overline{\text{INT4/WAKEUP}}^{\text{Note}}$
15	NU	35	SI2	55	$\overline{\text{HRD}}$	75	$\overline{\text{INT3}}$
16	NU	36	P3	56	$\overline{\text{HWR}}$	76	$\overline{\text{INT2}}$
17	NU	37	P2	57	HA0	77	$\overline{\text{INT1}}$
18	NU	38	P1	58	HA1	78	NU
19	NU	39	P0	59	CLKOUT	79	NU
20	EV <sub>DD</sub>	40	EV <sub>DD</sub>	60	EV <sub>DD</sub>	80	EV <sub>DD</sub>

**Note** The function of the  $\overline{\text{WAKEUP}}$  pin can be activated or deactivated by a mask option.

80-pin plastic fine-pitch BGA (9 × 9 mm)  
μPD77111F1-xxx-CN1

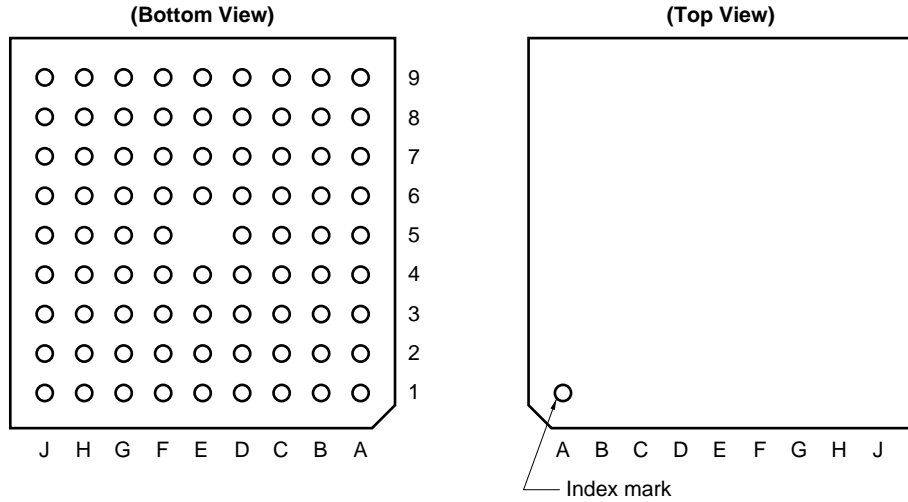

Pin No.	Pin Name	Pin No.	Pin Name	Pin No.	Pin Name	Pin No.	Pin Name
A1	EV <sub>DD</sub>	C3	NU	E6	$\overline{\text{HRE}}$	G8	HD4
A2	NU	C4	$\overline{\text{RESET}}$	E7	HD0	G9	HD5
A3	$\overline{\text{INT2}}$	C5	$\overline{\text{TRST}}$	E8	GND	H1	NU
A4	$\overline{\text{INT4/WAKEUP}}$ <sup>Note</sup>	C6	TICE	E9	EV <sub>DD</sub>	H2	NU
A5	IV <sub>DD</sub>	C7	CLKIN	F1	NU	H3	SIEN1
A6	TCK	C8	HA0	F2	NU	H4	SOEN1
A7	IV <sub>DD</sub>	C9	$\overline{\text{HWR}}$	F3	NU	H5	GND
A8	GND	D1	NU	F4	SIAK1	H6	SI2
A9	EV <sub>DD</sub>	D2	NU	F5	SOEN2	H7	P1
B1	NU	D3	NU	F6	P2	H8	GND
B2	GND	D4	$\overline{\text{INT1}}$	F7	HD1	H9	HD7
B3	NU	D5	TMS	F8	HD3	J1	EV <sub>DD</sub>
B4	$\overline{\text{INT3}}$	D6	TDO	F9	HD2	J2	GND
B5	GND	D7	$\overline{\text{HCS}}$	G1	NU	J3	SCK1
B6	TDI	D8	HRD	G2	NU	J4	SORQ1
B7	GND	D9	$\overline{\text{HWE}}$	G3	SI1	J5	IV <sub>DD</sub>
B8	CLKOUT	E1	EV <sub>DD</sub>	G4	SO1	J6	SCK2
B9	HA1	E2	GND	G5	SO2	J7	P3
C1	NU	E3	NU	G6	SIEN2	J8	P0
C2	NU	E4	NU	G7	HD6	J9	EV <sub>DD</sub>

**Note** The function of the  $\overline{\text{WAKEUP}}$  pin can be activated or deactivated by a mask option.

**PIN NAME**

$\overline{\text{BSTB}}$	: Bus Strobe
CLKIN	: Clock Input
CLKOUT	: Clock Output
D0 - D15	: 16-bit Data Bus
DA0 - DA14	: External Data Memory Address Bus
EV <sub>DD</sub>	: Power Supply for I/O Pins
GND	: Ground
HA0, HA1	: Host Data Access
$\overline{\text{HCS}}$	: Host Chip Select
HD0 - HD7	: Host Data Bus
$\overline{\text{HOLDAK}}$	: Hold Acknowledge
$\overline{\text{HOLDRQ}}$	: Hold Request
$\overline{\text{HRD}}$	: Host Read
$\overline{\text{HRE}}$	: Host Read Enable
$\overline{\text{HWE}}$	: Host Write Enable
$\overline{\text{HWR}}$	: Host Write
I.C.	: Internally Connected
$\overline{\text{INT1}} - \overline{\text{INT4}}$	: Interrupt
IV <sub>DD</sub>	: Power Supply for DSP Core
$\overline{\text{MRD}}$	: Memory Read Output
$\overline{\text{MWR}}$	: Memory Write Output
NC	: Non-Connection
NU	: Not Used
P0 - P3	: Port
PLL0 - PLL2	: PLL Multiple Rate Set
$\overline{\text{RESET}}$	: Reset
SCK1, SCK2	: Serial Clock Input
SI1, SI2	: Serial Data Input
SI <sub>AK1</sub>	: Serial Input Acknowledge
SI <sub>EN1</sub> , SI <sub>EN2</sub>	: Serial Input Enable
SO1, SO2	: Serial Data Output
SO <sub>EN1</sub> , SO <sub>EN2</sub>	: Serial Output Enable
SORQ1	: Serial Output Request
TCK	: Test Clock Input
TDI	: Test Data Input
TDO	: Test Data Output
TICE	: Test In-Circuit Emulator
TMS	: Test Mode Select
$\overline{\text{TRST}}$	: Test Reset
$\overline{\text{WAKEUP}}$	: Wakeup from STOP Mode
$\overline{\text{X/Y}}$	: X/Y Memory Select

**CONTENTS**

<b>1. PIN FUNCTION .....</b>	<b>13</b>
1.1 Pin Function Description .....	13
1.2 Connection of Unused Pins.....	18
<b>2. FUNCTION OUTLINE.....</b>	<b>20</b>
2.1 Program Control Unit .....	20
2.2 Arithmetic Unit.....	21
2.3 Data Memory Unit .....	22
2.4 Peripheral Units .....	22
<b>3. CLOCK GENERATOR .....</b>	<b>23</b>
<b>4. RESET FUNCTION .....</b>	<b>23</b>
4.1 Hardware Reset.....	23
4.2 Initializing PLL .....	24
<b>5. FUNCTIONS OF BOOT-UP ROM.....</b>	<b>24</b>
5.1 Boot at Reset.....	24
5.2 Reboot .....	25
5.3 Signature Operation .....	26
<b>6. STANDBY MODES .....</b>	<b>26</b>
6.1 HALT Mode.....	26
6.2 STOP Mode.....	27
<b>7. MEMORY MAP.....</b>	<b>27</b>
7.1 Instruction Memory .....	27
7.2 Data Memory .....	29
<b>8. MASK OPTION.....</b>	<b>30</b>
8.1 Clock Control Options.....	30
8.2 WAKEUP Function.....	31
8.3 Mask Option Equivalent Function of μPD77110.....	31
<b>9. INSTRUCTIONS .....</b>	<b>33</b>
9.1 Outline of Instructions .....	33
9.2 Instruction Set and Operation .....	34
<b>10. ELECTRICAL SPECIFICATIONS .....</b>	<b>40</b>
<b>11. PACKAGE .....</b>	<b>72</b>
<b>12. RECOMMENDED SOLDERING CONDITIONS.....</b>	<b>75</b>

1. PIN FUNCTION

Because the pin numbers differ depending on the package, refer to the diagram of the package to be used.

1.1 Pin Function Description

• Power supply

Pin Name	Pin No.			I/O	Function	Shared by:
	100-pin TQFP	80-pin TQFP	80-pin FBGA			
IV <sub>DD</sub>	35, 77, 85	31, 63, 71	A5, A7, J5	–	Power to DSP core (+2.5 V)	–
EV <sub>DD</sub>	25, 50, 64, 75, 100	10, 20, 40, 50, 60, 80	A1, A9, E1, E9, J1, J9	–	Power to I/O pins (+3 V)	–
GND	1, 26, 36, 51, 65, 76, 78, 86	1, 11, 21, 32, 41, 51, 61, 64, 72	A8, B2, B5, B7, E2, E8, H5, H8, J2	–	Ground	–

• System control

Pin Name	Pin No.			I/O	Function	Shared by:
	100-pin TQFP	80-pin TQFP	80-pin FBGA			
CLKIN	74	62	C7	Input	System clock input	–
CLKOUT	73	59	B8	Output	Internal system clock output	–
RESET	87	73	C4	Input	Internal system reset signal input	
PLL0	53	–	–	Input	PLL multiple setting input (μPD77110 only) • Determines the PLL multiple at reset as follows: PLL2: PLL1: PLL0: 000 : Selects PLL multiple of ×1. 001 : Selects PLL multiple of ×2. 010 : Selects PLL multiple of ×3. : 111 : Selects PLL multiple of ×8. • These pins have no function on the μPD77111 and 77112 .	P2
PLL1	52	–	–	Input		P3
PLL2	49	–	–	Input		–
WAKEUP	88	74	A4	Input	Stop mode release signal input. • When this pin is asserted active, the stop mode is released. The function of this pin can be activated or deactivated by a mask option. • This pin is always valid on the μPD77110 .	INT4

• Interrupt

Pin Name	Pin No.			I/O	Function	Shared by:
	100-pin TQFP	80-pin TQFP	80-pin FBGA			
$\overline{\text{INT1}} - \overline{\text{INT3}}$	91 - 89	77 - 75	D4, A3, B4	Input	External maskable interrupt input. • Detected at the falling edge.	–
$\overline{\text{INT4}}$	88	74	A4	Input		WAKEUP

• External data memory interface

Pin Name	Pin No.			I/O	Function	Shared by:
	100-pin TQFP	80-pin TQFP	80-pin FBGA			
$\overline{\text{X}}/\text{Y}$	99	–	–	Output (3S)	Memory select signal output. 0: Uses X memory. 1: Uses Y memory.	–
DA0 - DA14	16 - 2	–	–	Output (3S)	Address bus of external data memory. • Accesses the external memory. • Continuously outputs the external memory address accessed last when the external memory is not being accessed. Kept low (0x000) if the external memory is never accessed after reset. • DA14 is NC (no connection) and does not function on the μPD77112.	–
D0 - D15	34 - 27, 24 - 17	–	–	I/O (3S)	16-bit data bus. • Accesses the external memory.	–
$\overline{\text{MRD}}$	97	–	–	Output (3S)	Read output • External memory read	–
$\overline{\text{MWR}}$	96	–	–	Output (3S)	Write output • External memory write	–
$\overline{\text{HOLD}}\overline{\text{RQ}}$	92	–	–	Input	Hold request signal • Input a low level to this pin when the external device uses the external data memory bus of the μPD77110 and 77112.	–
$\overline{\text{BSTB}}$	94	–	–	Output	Bus strobe signal • This pin goes low when the μPD77110 and 77112 use the external data memory bus.	–
$\overline{\text{HOLD}}\overline{\text{AK}}$	93	–	–	Output	Hold acknowledge signal • This pin goes low when the external device is enabled to use the external data memory bus of the μPD77110 and 77112.	–

**Remark** Pins marked “3S” under the heading “I/O” go into a high-impedance state in the following conditions:  
 $\overline{\text{X}}/\text{Y}$ , DA0-DA14,  $\overline{\text{MRD}}$ ,  $\overline{\text{MWR}}$ : When the bus is released ( $\overline{\text{HOLD}}\overline{\text{AK}}$  = low level)  
 D0-D15: When the external data memory is not being accessed and when the bus is released ( $\overline{\text{HOLD}}\overline{\text{AK}}$  = low level)

• Serial interface

Pin Name	Pin No.			I/O	Function	Shared by:
	100-pin TQFP	80-pin TQFP	80-pin FBGA			
SCK1	39	24	J3	Input	Serial 1 clock input	–
SORQ1	42	27	J4	Output	Serial output 1 request	–
SOEN1	43	28	H4	Input	Serial output 1 enable	–
SO1	41	26	G4	Output (3S)	Serial data output 1	–
SIEN1	38	23	H3	Input	Serial input 1 enable	–
SI1	37	22	G3	Input	Serial data input 1	–
SIK1	40	25	F4	Output	Serial input 1 acknowledge	–
SCK2	46	33	J6	Input	Serial 2 clock input	–
SOEN2	44	29	F5	Input	Serial output 2 enable	–
SO2	45	30	G5	Output (3S)	Serial data output 2	–
SIEN2	47	34	G6	Input	Serial input 2 enable	–
SI2	48	35	H6	Input	Serial data input 2	–

**Remark** The pins marked “3S” under the heading “I/O” go into a high-impedance state on completion of data transfer and input of the hardware reset ( $\overline{\text{RESET}}$ ) signal.

• Host interface

Pin Name	Pin No.			I/O	Function	Shared by:
	100-pin TQFP	80-pin TQFP	80-pin FBGA			
HA1	72	58	B9	Input	Specifies the register to be accessed by HD7 through HD0. <ul style="list-style-type: none"> <li>• 1: Accesses the host interface status register (HST).</li> <li>• 0: Accesses the host transmit data register (HDT (out)) when read (<math>\overline{\text{HRD}} = 0</math>), and host receive data register (HDT (in)) when written (<math>\overline{\text{HWR}} = 0</math>).</li> </ul>	–
HA0	71	57	C8	Input	Specifies the register to be accessed by HD7 through HD0. <ul style="list-style-type: none"> <li>• 1: Accesses bits 15 through 8 of HST, HDT (in), and HDT (out).</li> <li>• 0: Accesses bits 7 through 0 of HST, HDT (in), and HDT (out).</li> </ul>	–
$\overline{\text{HCS}}$	68	54	D7	Input	Chip select input	–
$\overline{\text{HRD}}$	69	55	D8	Input	Host read input	–
$\overline{\text{HWR}}$	70	56	C9	Input	Host write input	–
$\overline{\text{HRE}}$	66	52	E6	Output	Host read enable output	–
$\overline{\text{HWE}}$	67	53	D9	Output	Host write enable output	–
HD0 - HD7	63 - 56	49 - 42	E7, F7, F9, F8, G8, G9, G7, H9	I/O (3S)	8-bit host data bus	–

**Remark** The pins marked “3S” under the heading “I/O” go into a high-impedance state when the host interface is not being accessed.

• I/O ports

Pin Name	Pin No.			I/O	Function	Shared by:
	100-pin TQFP	80-pin TQFP	80-pin FBGA			
P0	55	39	J8	I/O	General-purpose I/O port	–
P1	54	38	H7	I/O		–
P2	53	37	F6	I/O		PLL0 <sup>Note</sup>
P3	52	36	J7	I/O		PLL1 <sup>Note</sup>

**Note** Only the μPD77110. The μPD77111 and 77112 have no multiplexed pins.



• Debugging interface

Pin Name	Pin No.			I/O	Function	Shared by:
	100-pin TQFP	80-pin TQFP	80-pin FBGA			
TDO	79	65	D6	Output	For debugging	-
TICE	80	66	C6	Output		-
TCK	81	67	A6	Input		-
TDI	82	68	B6	Input		-
TMS	83	69	D5	Input		-
TRST	84	70	C5	Input		-

• Others

Pin Name	Pin No.			I/O	Function	Shared by:
	100-pin TQFP	80-pin TQFP	80-pin FBGA			
I.C.	98	-	-	-	Internally connected. Leave this pin unconnected.	-
NU	95	2, 3, 4, 5, 6, 7, 8, 9, 12, 13, 14, 15, 16, 17, 18, 19, 78, 79	A2, B1, B3, C1, C2, C3, D1, D2, D3, E3, E4, F1, F2, F3, G1, G2, H1, H2	-	No function pins. Connect these pins to EV <sub>DD</sub> .	-
NC	2, 49	-	-	-	No-connect pins (with μPD77112). Leave these pins unconnected.	-

**Caution** If any signal is input to these pins or if an attempt is made to read these pins, the normal operation of the μPD77110, 77111, and 77112 is not guaranteed.

## 1.2 Connection of Unused Pins

### 1.2.1 Connection of Function Pins

When mounting, connect unused pins as follows:

Pin	I/O	Recommended Connection
$\overline{\text{INT}}1 - \overline{\text{INT}}4$	Input	Connect to EV <sub>DD</sub> .
$\overline{\text{X}}/\text{Y}$	Output	Leave unconnected.
DA0 - DA14	Output	
D0 - D15 <sup>Note 1</sup>	I/O	Connect to EV <sub>DD</sub> via pull-up resistor, or connect to GND via pull-down resistor.
$\overline{\text{MRD}}$ , $\overline{\text{MWR}}$	Output	Leave unconnected.
$\overline{\text{HOLD}}\text{RQ}$	Input	Connect to EV <sub>DD</sub> .
$\overline{\text{BSTB}}$ , $\overline{\text{HOLD}}\text{AK}$	Output	Leave unconnected.
SCK1, SCK2	Input	Connect to EV <sub>DD</sub> or GND.
SI1, SI2	Input	
SIEN1, SIEN2	Input	Connect to GND.
SOEN1, SOEN2	Input	
SORQ1	Output	Leave unconnected.
SO1, SO2	Output	
SI <sub>AK</sub> 1	Output	
HA0, HA1	Input	Connect to EV <sub>DD</sub> or GND.
$\overline{\text{HCS}}$ , $\overline{\text{HRD}}$ , $\overline{\text{HWR}}$	Input	Connect to EV <sub>DD</sub> .
$\overline{\text{HRE}}$ , $\overline{\text{HWE}}$	Output	Leave unconnected.
HD0 - HD7 <sup>Note 2</sup>	I/O	Connect to EV <sub>DD</sub> via pull-up resistor, or connect to GND via pull-down resistor.
P0 - P3	I/O	
TCK	Input	Connect to GND via pull-down resistor.
TDO, TICE	Output	Leave unconnected.
TMS, TDI	Input	Leave unconnected. (internally pulled up).
$\overline{\text{TRST}}$	Input	Leave unconnected. (internally pulled down).
CLKOUT	Output	Leave unconnected.

- Notes**
1. These pins may be left unconnected if the external data memory is not accessed in the program. However, connect these pins as recommended in the halt and stop modes when the power consumption must be lowered.
  2. These pins may be left unconnected if  $\overline{\text{HCS}}$ ,  $\overline{\text{HRD}}$ , and  $\overline{\text{HWR}}$  are fixed to the high level. However, connect these pins as recommended in the halt and stop modes when the power consumption must be lowered.

**1.2.2 Connection of no-function pins**

Pin	I/O	Recommended Connection
I.C.	–	Leave unconnected.
NU	–	Connect to EV <sub>DD</sub> .
NC	–	Leave unconnected.

## 2. FUNCTION OUTLINE

### 2.1 Program Control Unit

This unit is used to execute instructions, and control branching, loops, interrupts, the clock, and the standby mode of the DSP.

#### 2.1.1 CPU control

A three-stage pipeline architecture is employed and almost all the instructions, except some instructions such as branch instructions, are executed in one system clock.

#### 2.1.2 Interrupt control

Interrupt requests input from external pins ( $\overline{\text{INT1}}$  through  $\overline{\text{INT4}}$ ) or generated by the internal peripherals (serial interface and host interface) are serviced. The interrupt of each interrupt source can be enabled or disabled. Multiple interrupts are also supported.

#### 2.1.3 Loop control task

A loop function without any hardware overhead is provided. A loop stack with four levels is provided to support multiple loops.

#### 2.1.4 PC stack

A 15-level PC stack that stores the program counter supports multiple interrupts and subroutine calls.

#### 2.1.5 PLL

A PLL is provided as a clock generator that can multiply or divide an external clock input to supply an operating clock to the DSP. The multiplication and division ratio are set as follows:

- $\mu$ PD77110: A multiple of  $\times 1$  to  $\times 8$  is specified by an external pin (division ratio is fixed).
- $\mu$ PD77111 and 77112: A multiple of  $\times 1$  to  $\times 16$  or a division ratio of  $1/1$  to  $1/16$  can be set by a mask option.

Two standby modes are available for lowering the power consumption while the DSP is not in use.

- HALT mode: Set by execution of the HALT instruction. The current consumption drops to several mA. The normal operation mode is recovered by an interrupt or hardware reset.
- STOP mode: Set by execution of the STOP instruction. The current consumption drops to several  $10 \mu\text{A}$ . The normal operation mode is recovered by hardware reset or  $\overline{\text{WAKEUP}}$  pin<sup>Note</sup>.

**Note** If the WAKEUP function is activated by mask option

#### 2.1.6 Instruction memory

The capacity and type of the memory differ depending on the model of the DSP.

64 words of the instruction RAM are allocated to interrupt vectors.

A boot-up ROM that boots up the instruction RAM is provided, and the instruction RAM can be initialized or rewritten by self boot (boot from the internal data ROM or external data space) or host boot (boot via host interface).

- $\mu$ PD77110: 35.5K-word RAM
- $\mu$ PD77111, 77112: 1K-word RAM and 31.75K-word ROM

## 2.2 Arithmetic Unit

This unit performs multiplication, addition, logical operations, and shift, and consists of a 40-bit multiply accumulator, 40-bit data ALU, 40-bit barrel shifter, and eight 40-bit general-purpose registers.

### 2.2.1 General-purpose registers (R0 through R7)

These eight 40-bit registers are used to input/output data for arithmetic operations, and load or store data from/to data memory.

A general-purpose register (R0 to R7) is made up of three parts: R0L through R7L (bits 15 through 0), R0H through R7H (bits 31 through 16), and R0E through R7E (bits 39 through 32). Depending on the type of operation, RnL, RnH, and RnE are used as one register or in different combinations.

### 2.2.2 Multiply accumulator (MAC)

The MAC multiplies two 16-bit values, and adds or subtracts the multiplication result from one 40-bit value, and outputs a 40-bit value.

The MAC is provided with a shifter (MSFT: MAC ShiFTer) at the stage preceding the input stage. This shifter can arithmetically shift the 40-bit value to be added to or subtracted from the multiplication result 1 or 16 bits to the right .

### 2.2.3 Arithmetic logic unit (ALU)

This unit inputs one or two 40-bit values, executes an arithmetic or logical operation, and outputs a 40-bit value.

### 2.2.4 Barrel shifter (BSFT: Barrel ShiFTer)

The barrel shifter inputs a 40-bit value, shifts it to the left or right by any number of bits, and outputs a 40-bit value. The data may be arithmetically shifted to the right shifted to the right, in which case the data is sign-extended, or logically shifted to the right, in which case 0 is inserted from the MSB.

## 2.3 Data Memory Unit

The data memory unit consists of two banks of data memory and two data addressing units.

### 2.3.1 Data memory

The capacity and type of the memory differ depending on the model of the DSP. All DSPs have two banks of data memory (X data memory and Y data memory). A 64-word peripheral area is assigned in the data memory space.

- $\mu$ PD77110: RAM of 24K words  $\times$  2 banks
- $\mu$ PD77111, 77112: RAM of 3K words  $\times$  2 banks and ROM of 16K words  $\times$  2 banks

In addition, some models have an external data memory interface so that the external memory can be expanded.

- $\mu$ PD77110: External data memory of 32K words  $\times$  2 banks
- $\mu$ PD77112: External data memory of 16K words  $\times$  2 banks

### 2.3.2 Data addressing unit

An independent data addressing unit is provided for each of the X data memory and Y data memory spaces.

Each data addressing unit has four data pointers (DPn), four index registers (DNn), one modulo register (DMX or DMY), and an address ALU.

## 2.4 Peripheral Units

A serial interface, host interface, general-purpose I/O port, and wait cycle register are provided. All these internal peripherals are mapped to the X data memory and Y data memory spaces, and are accessed from program as memory-mapped I/Os.

### 2.4.1 Serial interface (SIO)

Two serial interfaces are provided. These serial interfaces have the following features:

- Serial clock : Supplied from external source to each interface. The same clock is used for input and output on the interface.
- Frame length: 8 or 16 bits, and MSB or LSB first selectable for each interface and input or output
- Handshake : Handshaking with external devices is implemented with a dedicated status signal. With the internal units, polling, wait, or interrupt are used.

### 2.4.2 Host interface (HIO)

This is an 8-bit parallel port that inputs data from or outputs data to an external host CPU or DMA controller. In the DSP, a 16-bit register is mapped to memory for input data, output data, and status. Handshaking with an external device is implemented by using a dedicated status signal. Handshaking with internal units is achieved by means of polling, wait, or interrupts.

### 2.4.3 General-purpose I/O port (PIO)

This is a 4-bit I/O port that can be set in the input or output mode in 1-bit units.

**2.4.4 Wait cycle register**

The number of wait cycles to be inserted when the external data memory area is accessed can be specified in advance by using a register (DWTR)<sup>Note</sup>. The number of wait cycles that can be set is 1, 3, or 7.

**Note** This function is not available on the  $\mu$ PD77111 because this DSP does not have an external data area.

**3. CLOCK GENERATOR**

The clock generator generates an internal system clock based on the external clock input from the CLKIN pin and supplies the generated clock to the internal units of the DSP.

For details of how to set the PLL multiple, refer to **4.2 Initializing PLL**, **8.1 Clock Control Options**, and **8.3.1 Settings related to clock control**.

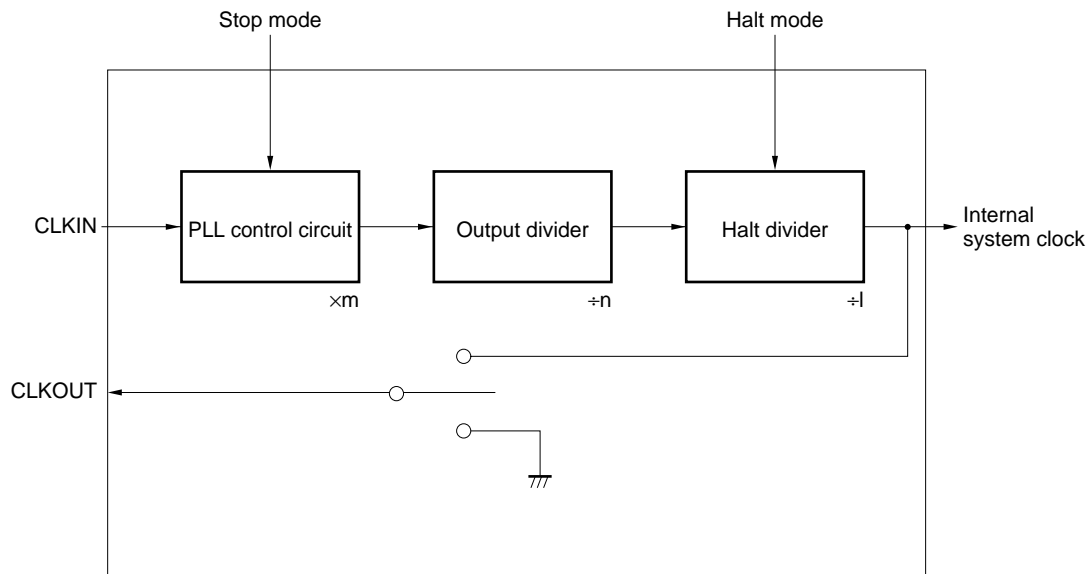

**4. RESET FUNCTION**

When a low level of a specified width is input to the  $\overline{\text{RESET}}$  pin, the device is initialized.

**4.1 Hardware Reset**

If the  $\overline{\text{RESET}}$  pin is asserted active (low level) for a specified period, the internal circuitry of the DSP is initialized. If the  $\overline{\text{RESET}}$  pin is then deasserted inactive (high level), boot processing of the instruction RAM is performed according to the status of the port pins (P0 and P1). After boot processing, processing is executed starting from the instruction at address 0x200 of instruction memory (reset entry).

On power application, the  $\overline{\text{RESET}}$  pin must be asserted active (low level) after 4 input clocks have been input with the  $\overline{\text{RESET}}$  pin in the inactive status (high level), after the supply voltage has reached the level of the operating voltage. In other words, no power-ON reset function is available. On power application, the PLL must be initialized.

### 4.2 Initializing PLL

Initializing the PLL starts from the 1024th input clock after the  $\overline{\text{RESET}}$  pin has been asserted active (low level). Initialization takes 1024 clocks and it takes the PLL 100 μs to be locked.

After that, the DSP operates with the set value of the PLL specified by a mask option (μPD77111 or 77112) or an external pin (μPD77110) when the  $\overline{\text{RESET}}$  pin is deasserted inactive (high level).

After initializing the PLL, be sure to execute boot-up processing to re-initialize the internal RAM. To initialize the PLL, the internal memory contents and register status of the DSP are not retained.

If the  $\overline{\text{RESET}}$  pin is deasserted inactive before the PLL initialization mode is set, the DSP is normally reset (the PLL is not initialized).

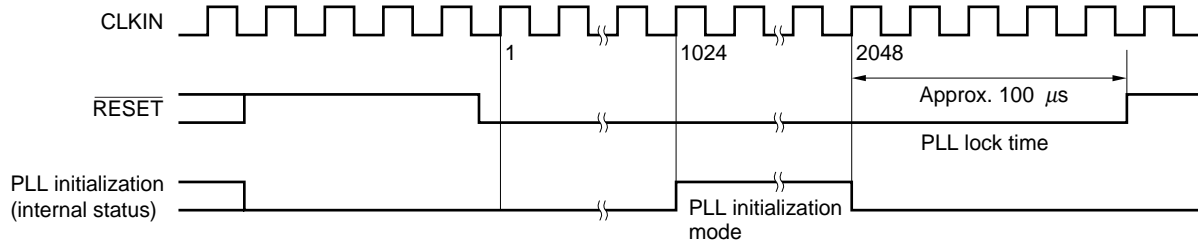

**Caution** Do not deassert the  $\overline{\text{RESET}}$  signal inactive in the PLL initialization mode and during PLL lock period.

## 5. FUNCTIONS OF BOOT-UP ROM

To rewrite the contents of the instruction memory on power application or from program, boot up the instruction RAM by using the internal boot-up ROM.

The μPD77110 has a function to verify the contents of the internal instruction RAM in the boot-up ROM.

### 5.1 Boot at Reset

After hardware reset has been cleared, the boot program first reads the general-purpose I/O ports P0 and P1 and, depending on their bit pattern, determines the boot mode (self boot or host boot). After boot processing, processing is executed starting from the instruction at address 0x200 (reset entry) of the instruction memory.

The pins (P0 and P1) that specify the boot mode must be kept stable for the duration of 3 clocks before and for the duration of 12 clocks after reset has been cleared (the clock is input from CLKIN).

P1	P0	Boot Mode
0	0	Does not execute boot but branches to address 0x200 <sup>Note</sup> .
0	1	Executes host boot and then branches to address 0x200.
1	1	Executes self boot and then branches to address 0x200.
1	0	Setting prohibited

**Note** This setting is used when the DSP must be reset to recover from the standby mode after reset boot has been executed once.



**5.1.1 Self boot**

The boot-up ROM transfers the instruction code stored in the data memory space to the instruction RAM, based on the boot parameter written to address 0x4000 of the Y data memory. Generally, with a mask ROM model (μPD77111 or 77112), this function is implemented by storing the instructions to be booted in the data ROM.

In addition, the instructions to be booted can be also stored in an external data area in the form of flash ROM, and self boot can be executed from this external data area.

With the μPD77110, the value of address 0x4000 of the Y data memory is undefined on power application, because this address is in RAM. Therefore, with the μPD77110, the self boot mode cannot be selected on power application, and host boot must be executed. This also applies when the PLL is initialized. By writing a boot parameter to address 0x4000 or those that follow of the Y data memory, self boot can be executed when the RESET signal is subsequently input (except the reset that initializes the PLL). In this case, however, the instructions to be booted are only those at address 0x0200 through 0x0FFF of the instruction RAM.

**5.1.2 Host boot**

In this boot mode, a boot parameter and instruction code are obtained via the host interface, and transferred to the instruction RAM.

With the μPD77110, the host boot mode is used on power application. The boot instruction area is the instruction RAM from addresses 0x0200 through 0x0FFF. To boot up the instruction RAM from 0x4000 through 0xBFFF, host reboot is used.

**5.2 Reboot**

By calling the next reboot entry from the program, the contents of the instruction RAM can be rewritten. In particular, the μPD77110 has a reboot function that boots up the instruction RAM from 0x4000 through 0xBFFF.

Reboot Mode			Entry Address
Self boot	X memory	Word reboot	0x2
		Byte reboot	0x4
	Y memory	Word reboot	0x1
		Byte reboot	0x3
Host boot	Host reboot	0x6 (μPD77110) 0x5 (μPD77111, 77112)	

**5.2.1 Self reboot**

The instruction codes stored in the data memory are transferred to the instruction RAM.

This boot mode cannot be used with the μPD77110.

Set the following parameters and call the entry address of the corresponding reboot mode to execute self reboot.

- R7L: Number of instruction steps for rebooting
- DP3: First address of X memory in which instruction codes are stored (in the case of reboot from X memory), or first address of the instruction memory to be loaded (in the case of reboot from Y memory)
- DP7: First address of instruction memory to be loaded (in the case of reboot from X memory), or first address of X memory in which instruction codes are stored (in the case of reboot from Y memory)

### 5.2.2 Host reboot

An instruction code is obtained via the host interface and transferred to the instruction RAM.

With the  $\mu$ PD77110, the host reboot mode is used to boot up the instruction RAM from addresses 0x4000 through 0xBFFF. Areas 0x0200 through 0x0FFF and 0x4000 through 0xBFFF cannot be rebooted all at once.

The entry address of the  $\mu$ PD77110 is 0x6, and that of the  $\mu$ PD77111 and 77112 is 0x5. Host reboot is executed by calling this address after setting the following parameter:

- R7L: Number of instruction steps for rebooting
- DP3: First address of instruction memory to be loaded

### 5.3 Signature Operation

The  $\mu$ PD77110 has a signature operation function so that the contents of the internal instruction RAM can be verified. The signature operation performs a specific arithmetic operation on the data in the instruction RAM booted up, and returns the result to a register. Perform the signature operation in advance on the device when it is operating normally, and repeat the signature operation later to check whether the data in RAM is correct by comparing the operation result with the previous result. If the results are identical, there is no problem.

The entry address is 0x9. Execute the operation by calling this address after setting the following parameter. Note that the operation cannot be performed on the areas 0x0200 through 0x0FFF and 0x4000 through 0xBFFF at the same time. The operation result is stored in register R7.

- R7L: Number of instruction steps for operation
- DP3: First address of instruction memory for operation

## 6. STANDBY MODES

Two standby modes are available. By executing the corresponding instruction, each mode is set and the power consumption can be reduced.

### 6.1 HALT Mode

To set this mode, execute the HALT instruction. In this mode, functions other than clock circuit and PLL are stopped to reduce the current consumption.

To release the HALT mode, use an interrupt or hardware reset. When releasing the HALT mode using an interrupt, the contents of the internal registers and memory are retained. It takes several 10 system clocks to release the HALT mode when the HALT mode is released using an interrupt.

In the HALT Mode, the clock circuit of the  $\mu$ PD77111 family supplies the following clock as the internal system clock. The clock output from the CLKOUT pin is as follows.

The clock output from the CLKOUT pin, however, has a high-level width that is equivalent to 1 cycle of the normal operation (i.e., the duty factor is not 50%).

- $\mu$ PD77110: 1/8 of internal system clock
- $\mu$ PD77111, 77112: 1/l of internal system clock (l = integer from 1 to 16, specified by mask option)

## 6.2 STOP Mode

To set this mode, execute the STOP instruction. In this mode, all the functions, including the clock circuit and PLL, are stopped and the power consumption is minimized with only leakage current flowing.

To release the STOP mode, use hardware reset or  $\overline{\text{WAKEUP}}$  pin.

When releasing the STOP mode by using the  $\overline{\text{WAKEUP}}$  pin, the contents of the internal registers and memory are retained, but it takes several 100 μs to release the mode.

The  $\overline{\text{WAKEUP}}$  pin is multiplexed with the  $\overline{\text{INT4}}$  pin. Usually, this pin functions as an interrupt pin, but functions as the  $\overline{\text{WAKEUP}}$  pin when it is asserted active in the STOP mode. Whether the  $\overline{\text{WAKEUP}}$  pin is used to release the STOP mode is selected by mask option. For details, refer to **8.2 WAKEUP Function** and **8.3.2 WAKEUP function**.

## 7. MEMORY MAP

A Harvard architecture, in which the instruction memory space and data memory space are separated is employed.

### 7.1 Instruction Memory

#### 7.1.1 Instruction memory map

The instruction memory space consists of 64K words × 32 bits, and the capacity and type of the memory differ depending on the product.

μPD77110		μPD77111, 77112	
0xFFFF	System		System
0xC000	Internal instruction RAM (32K words)	0xBF00	Internal instruction ROM (31.75K words)
0xBFFF		0xBEFF	
0x4000	System		System
0x3FFF	Internal instruction RAM (3.5K words)	0x0600	Internal instruction RAM (1K words)
0x1000		0x05FF	
0x0FFF	Vector area (64 words)		Vector area (64 words)
0x0240	System		System
0x023F			
0x0200	Boot-up ROM (256 words)		Boot-up ROM (256 words)
0x01FF			
0x0100			
0x00FF			
0x0000			

**Caution** Programs and data cannot be placed at addresses reserved for the system, nor can these addresses be accessed. If these addresses are accessed, the normal operation of the device cannot be guaranteed.

### 7.1.2 Interrupt vector table

Addresses 0x200 through 0x23F of the instruction memory are entry points (vectors) of interrupts. Four instruction addresses are assigned to each interrupt source.

Vector	Interrupt Source
0x200	Reset
0x204	Reserved
0x208	
0x20C	
0x210	INT1
0x214	INT2
0x218	INT3
0x21C	INT4
0x220	SI1 input
0x224	SO1 output
0x228	SI2 input
0x22C	SO2 output
0x230	HI input
0x234	HO output
0x238	Reserved
0x23C	

- Cautions**
1. Although reset is not an interrupt, it is handled like an interrupt as an entry to a vector.
  2. It is recommended that unused interrupt source vectors be used to branch an error processing routine.
  3. Because a vector area also exists in the internal RAM area of the mask ROM model, this area must be booted up. In addition, because the entry address after reset is 0x200, address 0x200 must be booted up even when the internal instruction RAM and interrupts are not used.

7.2 Data Memory

7.2.1 Data memory map

The data memory space consists of an X memory space and a Y memory space of 64K words × 16 bits each, and the memory capacity and memory type differ depending on the product.

	μPD77110		μPD77111		μPD77112
0xFFFF	External data memory (32K words)		System	0xC000 0xBFFF	External data memory (16K words)
					System
0x8000 0x7FFF	Data RAM (16K words)		Data ROM (16K words)		Data ROM (16K words)
0x4000 0x3FFF	System		System		System
0x3840 0x383F	Peripheral (64 words)		Peripheral (64 words)		Peripheral (64 words)
0x3800 0x37FF	System		System		System
0x3000 0x2FFF	Data RAM (4K words)				
0x2000 0x1FFF	System				
0x1000 0x0FFF	Data RAM (4K words)	0x0C00 0x0BFF	Data RAM (3K words)		Data RAM (3K words)
0x0000					

**Caution** Programs and data cannot be placed at addresses reserved for the system, nor can these addresses be accessed. If these addresses are accessed, the normal operation of the device cannot be guaranteed.

**7.2.2 Internal peripherals**

The internal peripherals are mapped to the internal data memory space.

X/Y Memory Address	Register Name	Function	Peripheral Name
0x3800	SDT1	First serial data register	SIO
0x3801	SST1	First serial status register	
0x3802	SDT2	Second serial data register	
0x3803	SST2	Second serial status register	
0x3804	PDT	Port data register	IOP
0x3805	PCD	Port command register	
0x3806	HDT	Host data register	HIO
0x3807	HST	Host status register	
0x3808	DWTR	Data memory wait cycle register	WTR
0x3809 - 0x383F	Reserved area	<b>Caution Do not access this area.</b>	-

- Cautions**
1. The register names listed in this table are not reserved words of the assembler or the C language. Therefore, when using these names in assembler or C, the user must define them.
  2. The same register is accessed, as long as the address is the same, regardless of whether the X memory space or Y memory space is accessed.
  3. Even different registers cannot be accessed at the same time from both the X and Y memory spaces.

**8. MASK OPTION**

The μPD77111 and 77112 have mask options that must be specified when an order for a ROM is placed. This section explains these mask options. The mask options are specified in the Workbench (WB77016) development tool. To order a mask ROM, output a mask ROM ordering file format (.msk file) using WB77016.

**8.1 Clock Control Options**

The following four clock related options must be specified.

- PLL multiple
- Output division ratio
- HALT division ratio
- Validity of CLKOUT pin

When the PLL multiple is m, output division ratio is n, and halt division ratio is l, the relationship between each operation mode and operating clock is as follows:

Operation Mode	Clock Supplied Inside DSP
Normal operation mode	m/n times external input clock
HALT mode	m/n/l times external input clock
STOP mode	Stopped

The PLL control circuit multiplies the input clock by an integer from 1 to 16. Specify the mask option of the PLL multiple so that the multiplied frequency falls within the specified PLL lock frequency range.

The output divider divides the clock multiplied by the PLL by an integer from 1 to 16. Specify the mask option of the output division ratio so that the frequency m/n times the external input clock supplied to the DSP falls within the specified operating frequency range of the DSP.

The HALT divider functions only in the HALT mode. It divides the clock of the output divider by an integer from 1 to 16 and supplies the divided clock to the internal circuitry. Specify the mask option of the HALT division ratio so that necessary division can be performed.

Whether the clock supplied to the internal circuitry of the DSP (internal system clock) is “output” or “not output” from the CLKOUT pin can be specified. Specify the mask option as necessary.

If an odd value (other than 1) is specified as the output division ratio, the high-level width of the clock output from the CLKOUT pin is equal to one cycle during normal operation (i.e., the clock does not have a duty factor of 50%).

### 8.2 WAKEUP Function

The  $\overline{\text{WAKEUP}}$  pin can be used to release the STOP mode as well as a hardware reset.

If the STOP mode is released by means of a hardware reset, the status before the STOP mode was set cannot be restored after the STOP mode has been released. If the  $\overline{\text{WAKEUP}}$  pin is used, however, the status before the STOP mode is set can be retained and program execution can be resumed starting from the instruction after the STOP instruction.

Whether the  $\overline{\text{WAKEUP}}$  pin is used to release the STOP mode can be specified by a mask option.

When the WAKEUP function is specified valid, the  $\overline{\text{WAKEUP}}$  pin is multiplexed with the  $\overline{\text{INT4}}$  pin and it usually functions as an interrupt pin. The pin functions as the  $\overline{\text{WAKEUP}}$  pin only in the STOP mode (if this pin is asserted active in the STOP mode, it is used only to release the STOP mode, and execution does not branch to an interrupt vector).

### 8.3 Mask Option Equivalent Function of μPD77110

Because the μPD77110 does not have mask options, the multiple of the PLL cannot be specified in the same manner as the μPD77111 and 77112. However, an external pin on the μPD77110 has a function equivalent to the mask option. Care must be exercised when using the μPD77110, including when it is used to emulate the μPD77111 and 77112.

**8.3.1 Settings related to clock control**

External pins PLL0 through PLL2 are used to set the multiple of the PLL. PLL0 and PLL1 are multiplexed with general-purpose I/O ports P2 and P3, and can be used as PLL setting pins only when it is so specified.

The multiple must be an integer from 1 to 8.

```
<PLL2: PLL1: PLL0> 000 m = 1
                    001 m = 2
                    :
                    111 m = 8
```

The output division ratio is fixed to 1/1 and the halt division ratio is fixed to 1/8.

Where the PLL multiple is m, the relationship between each operation mode and operating clock is as follows:

Operation Mode	Clock Supplied to DSP
Normal operation mode	m times external input clock
HALT mode	m/8 times external input clock
STOP mode	Stopped

For details on how to set the PLL multiple, refer to **4.2 Initializing PLL**. Because the setting of PLL0 through PLL2 becomes valid in the PLL initialization mode, the value of PLL0 through PLL2 must be fixed before the PLL initialization mode is set.

The option that makes CLKOUT pin output valid or invalid is fixed to "valid".

**8.3.2 WAKEUP function**

The WAKEUP function of the μPD77110 is fixed to "valid".



## 9. INSTRUCTIONS

### 9.1 Outline of Instructions

An instruction consists of 32 bits. Almost all the instructions, except some such as branch instructions, are executed with one system clock. The maximum instruction cycle of the  $\mu$ PD77110 is 15.3 ns. The maximum instruction cycle of the  $\mu$ PD77111 and 77112 is 13.3 ns. The following nine types of instructions are available:

**(1) Trinomial operation instructions**

These instructions specify an operation by the MAC. As the operands, three general-purpose registers can be specified.

**(2) Binomial operation instructions**

These instructions specify an operation by the MAC, ALU, or BSFT. As the operands, two general-purpose registers can be specified. An immediate value can be specified for some of these instructions, instead of a general-purpose register, for one input.

**(3) Uninomial operation instructions**

These instructions specify an operation by the ALU. As the operands, one general-purpose register can be specified.

**(4) Load/store instructions**

These instructions transfer 16-bit values between memory and a general-purpose register. Any general-purpose register can be specified as the transfer source or destination.

**(5) Register-to-register transfer instructions**

These instructions transfer data from one general-purpose register to another.

**(6) Immediate value setting instructions**

These instructions write an immediate value to a general-purpose register and the registers of the address operation unit.

**(7) Branch instructions**

These instructions specify branching of program execution.

**(8) Hardware loop instructions**

These instructions specify repetitive execution of an instruction.

**(9) Control instructions**

These instructions are used to control the program.

**9.2 Instruction Set and Operation**

An operation is written in the operation field for each instruction in accordance with the operation representation format of that instruction. If two or more parameters can be written, select one of them.

**(a) Representation formats and selectable registers**

The following table shows the representation formats and selectable registers.

Representation Format	Selectable Register
r0, r0', r0''	R0 - R7
rl, rl'	R0L - R7L
rh, rh'	R0H - R7H
re	R0E - R7E
reh	R0EH - R7EH
dp	DP0 - DP7
dn	DN0 - DN7
dm	DMX, DMY
dpx	DP0 - DP3
dpy	DP4 - DP7
dpx_mod	DPn, DPn++, DPn--, DPn##, DPn%%, !DPn## (n = 0 - 3)
dpy_mod	DPn, DPn++, DPn--, DPn##, DPn%%, !DPn## (n = 4 - 7)
dp_imm	DPn##imm (n = 0 - 7)
*xxx	Contents of memory with address xxx <Example> If the contents of the DP0 register are 1000, *DP0 indicates the contents of address 1000 of the memory.

**(b) Modifying data pointer**

The data pointer is modified after the memory has been accessed. The result of modification becomes valid starting from the instruction that immediately follows. The data pointer cannot be modified.

Example	Operation
DPn	Nothing is done (value of DPn is not changed.)
DPn++	$DPn \leftarrow DPn + 1$
DPn--	$DPn \leftarrow DPn - 1$
DPn##	$DPn \leftarrow DPn + DNn$ (Adds value of corresponding DN0 to DN7 to DP0 to DP7.) Example: $DP0 \leftarrow DP0 + DN0$
DPn%%	$(n = 0 - 3) DPn = ((DP_L + DNn) \bmod (DMX + 1)) + DP_H$
	$(n = 4 - 7) DPn = ((DP_L + DNn) \bmod (DMY + 1)) + DP_H$
!DPn##	Reverses bits of DPn and then accesses memory. After memory access, $DPn \leftarrow DPn + DNn$
DPn##imm	$DPn \leftarrow DPn + imm$

**(c) Instructions that can be simultaneously written**

Instructions that can be simultaneously written are indicated by O.

**(d) Status of overflow flag (OV)**

The status of the overflow flag is indicated by the following symbol:

- : Not affected
- †: Set to 1 when overflow occurs

**Caution** If an overflow does not occur as a result of an operation, the overflow flag is not reset but retains the status before the operation.

Instruction Set

Instruction	Instruction Name	Mnemonic	Operation	Instructions Simultaneously Written										Flag	
				Trinomial	Binomial	Uninomial	Load/store	Transfer	Immediate-value	Branch	Loop	Control	OV		
Trinomial operation	Multiply add	$ro = ro + rh * rh'$	$ro \leftarrow ro + rh * rh'$				○								‡
	Multiply sub	$ro = ro - rh * rh'$	$ro \leftarrow ro - rh * rh'$				○								‡
	Sign unsign multiply add	$ro = ro + rh * rl$ (rl is in positive integer format.)	$ro \leftarrow ro + rh * rl$				○								‡
	Unsign unsign multiply add	$ro = ro + rl * rl'$ (rl and rl' are in positive integer format.)	$ro \leftarrow ro + rl * rl'$				○								‡
	1-bit shift multiply add	$ro = (ro >> 1) + rh * rh'$	$ro \leftarrow \frac{ro}{2} + rh * rh'$				○								‡
	16-bit shift multiply add	$ro = (ro >> 16) + rh * rh'$	$ro \leftarrow \frac{ro}{2^{16}} + rh * rh'$				○								●
Binomial operation	Multiply	$ro = rh * rh'$	$ro \leftarrow rh * rh'$				○								●
	Add	$ro'' = ro + ro'$	$ro'' \leftarrow ro + ro'$				○								‡
	Immediate add	$ro' = ro + imm$	$ro' \leftarrow ro + imm$ (where $imm \neq 1$ )												‡
	Sub	$ro'' = ro - ro'$	$ro'' \leftarrow ro - ro'$				○								‡
	Immediate sub	$ro' = ro - imm$	$ro \leftarrow ro - imm$ (where $imm \neq 1$ )												‡
	Arithmetic right shift	$ro' = ro \text{ SRA } rl$	$ro' \leftarrow ro >> rl$				○								●
	Immediate arithmetic right shift	$ro' = ro \text{ SRA } imm$	$ro' \leftarrow ro >> imm$												●
	Logical right shift	$ro' = ro \text{ SRL } rl$	$ro' \leftarrow ro >> rl$				○								●
	Immediate logical right shift	$ro' = ro \text{ SRL } imm$	$ro' \leftarrow ro >> imm$												●
	Logical left shift	$ro' = ro \text{ SLL } rl$	$ro' \leftarrow ro << rl$				○								●
	Immediate logical left shift	$ro' = ro \text{ SLL } imm$	$ro' \leftarrow ro << imm$												●
	AND	$ro'' = ro \& ro'$	$ro'' \leftarrow ro \& ro'$				○								●
	Immediate AND	$ro' = ro \& imm$	$ro' \leftarrow ro \& imm$												●
	OR	$ro'' = ro   ro'$	$ro'' \leftarrow ro   ro'$				○								●
	Immediate OR	$ro' = ro   imm$	$ro' \leftarrow ro   imm$												●
Exclusive OR	$ro'' = ro \wedge ro'$	$ro'' \leftarrow ro \wedge ro'$				○								●	
Immediate exclusive OR	$ro' = ro \wedge imm$	$ro' \leftarrow ro \wedge imm$												●	

Instruc- tion	Instruction Name	Mnemonic	Operation	Instructions Simultaneously Written									Flag		
				Trino- mial	Bino- mial	Unino- mial	Load/ store	Trans- fer	Imme- diate- value	Bran- ch	Loop	Cont- rol	OV		
Binomial operation	Less than	ro'' = LT (ro, ro')	if (ro < ro') {ro'' ← 0x0000000001} else {ro'' ← 0x0000000000}				○								●
Uninomial operation	Clear	CLR (ro)	ro ← 0x0000000000				○							○	●
	Increment	ro' = ro + 1	ro' ← ro + 1				○							○	‡
	Decrement	ro' = ro - 1	ro' ← ro - 1				○							○	‡
	Absolute value	ro' = ABS (ro)	if (ro < 0) {ro' ← -ro} else {ro' ← ro}				○							○	‡
	1's complement	ro' = ~ro	ro' ← ~ro				○							○	●
	2's complement	ro' = -ro	ro' ← -ro				○							○	‡
	Clip	ro' = CLIP (ro)	if (ro > 0x007FFFFFFF) {ro' ← 0x007FFFFFFF} elseif (ro < 0xFF80000000) {ro' ← 0xFF80000000} else {ro' ← ro}				○							○	●
	Round	ro' = ROUND (ro)	if (ro > 0x007FFF0000) {ro' ← 0x007FFF0000} elseif (ro < 0xFF80000000) {ro' ← 0xFF80000000} else {ro' ← (ro + 0x8000) & 0xFFFFF0000}				○							○	●
	Exponent	ro' = EXP (ro)	ro' ← log <sub>2</sub> ( $\frac{1}{ro}$ )				○							○	●
	Substitution	ro' = ro	ro' ← ro				○							○	●
	Accumulated addition	ro' += ro	ro' ← ro' + ro				○							○	‡
	Accumulated subtraction	ro' -= ro	ro' ← ro' - ro				○							○	‡
Division	ro' / = ro	if (sign (ro') == sign (ro)) {ro' ← (ro' - ro) << 1} else {ro' ← (ro' + ro) << 1} if (sign (ro') == 0) {ro' ← ro' + 1}				○							○	‡	

Instruction	Instruction Name	Mnemonic	Operation	Instructions Simultaneously Written										Flag					
				Trino- mial	Bino- mial	Unino- mial	Load/ store	Trans- fer	Imme- diate- value	Bran- ch	Loop	Cont- rol	OV						
Load/ store	Parallel load/store <sup>Notes 1, 2</sup>	ro = *dpx_mod ro' = *dpy_mod	ro ← *dpx, ro' ← *dpy	○	○	○												●	
		ro = *dpx_mod *dpy_mod = rh	ro ← *dpx, *dpy ← rh																
		*dpx_mod = rh ro = *dpy_mod	*dpx ← rh, ro ← *dpy																
		*dpx_mod = rh *dpy_mod = rh'	*dpx ← rh, *dpy ← rh'																
	Partial load/ store <sup>Notes 1, 2, 3</sup>	dest = *dpx_mod dest' = *dpy_mod	dest ← *dpx, dest' ← *dpy																●
		dest = *dpx_mod *dpy_mod = source	dest ← *dpx, *dpy ← source																
		*dpx_mod = source dest = *dpy_mod	*dpx ← source, dest ← *dpy																
		*dpx_mod = source *dpy_mod = source'	*dpx ← source, *dpy ← source'																
	Direct addressing load/store <sup>Note 4</sup>	dest = *addr	dest ← *addr																●
		*addr = source	*addr ← source																
	Immediate value index load/store <sup>Note 5</sup>	dest = *dp_imm	dest ← *dp																●
		*dp_imm = source	*dp ← source																
Register- to-register transfer	dest = rl	dest ← rl															○	●	
	rl = source	rl ← source																	
Immediate value setting	rl = imm (where imm = 0 to 0xFFFF)	rl ← imm																●	
	dp = imm (where imm = 0 to 0xFFFF)	dp ← imm																	
	dn = imm (where imm = 0 to 0xFFFF)	dn ← imm																	
	dm = imm (where imm = 1 to 0xFFFF)	dm ← imm																	

- Notes**
1. Of the two mnemonics, either one of them or both can be written.
  2. After transfer, modification specified by mod is performed.
  3. Select any of dest, dest' = {ro, reh, re, rh, rl}, source, source' = {re, rh, rl}.
  4. Select any of dest = {ro, reh, re, rh, rl}, source = {re, rh, rl}, addr =  $\left. \begin{matrix} 0: X-0xFFFF : X (X \text{ memory}) \\ 0: Y-0xFFFF: Y (Y \text{ memory}) \end{matrix} \right\}$ .
  5. Select any of dest = {ro, reh, re, rh, rl}, source = {re, rh, rl}.
  6. Select any register other than general-purpose registers as dest and source.

Instruc- tion	Instruction Name	Mnemonic	Operation	Instructions Simultaneously Written									Flag	
				Trino- mial	Bino- mial	Unino- mial	Load/ store	Trans- fer	Imme- diate- value	Bran- ch	Loop	Cont- rol	OV	
Branch	Jump	JMP imm	PC ← imm										○	●
	Register indirect jump	JMP dp	PC ← dp										○	●
	Subroutine call	CALL imm	SP ← SP + 1 STK ← PC + 1 PC ← imm										○	●
	Register indirect subroutine call	CALL dp	SP ← SP + 1 STK ← PC + 1 PC ← dp										○	●
	Return	RET	PC ← STK SP ← SP - 1										○	●
	Interrupt return	RETI	PC ← STK STK ← SP - 1 Recovery of interrupt enable flag										○	●
Hard- ware loop	Repeat	REP count	Start RC ← count RF ← 0 During repeat PC ← PC RC ← RC - 1 End PC ← PC + 1 RF ← 1											●
	Loop	LOOP count (instruction of two or more lines)	Start RC ← count RF ← 0 During repeat PC ← PC RC ← RC - 1 End PC ← PC + 1 RF ← 1											●
	Loop hop	LPOP	LC ← LSR3 LE ← LSR2 LS ← LSR1 LSP ← LSP - 1											●
Control	No operation	NOP	PC ← PC + 1											●
	Halt	HALT	CPU stops.											●
	Stop	STOP	CPU, PLL, and OSC stop.											●
	Condition	IF (ro cond)	Condition test			○		○			○			●
	Forget interrupt	FINT	Discard interrupt request											●

10. ELECTRICAL SPECIFICATIONS

Absolute Maximum Ratings (T<sub>A</sub> = +25°C)

Parameter	Symbol	Condition	Rating	Unit
Supply voltage	IV <sub>DD</sub>	For DSP core	- 0.5 to +3.6	V
	EV <sub>DD</sub>	For I/O pins	-0.5 to +4.6	V
Input voltage	V <sub>I</sub>	V <sub>I</sub> < EV <sub>DD</sub> + 0.5 V	-0.5 to +4.1	V
Output voltage	V <sub>O</sub>		-0.5 to +4.1	V
Storage temperature	T <sub>stg</sub>		-65 to +150	°C
Operating temperature	T <sub>A</sub>		-40 to +85	°C

**Caution** If any of the parameters exceeds the absolute maximum ratings, even momentarily, the quality of the product may be impaired. The absolute maximum ratings are values that may physically damage the product(s). Be sure to use the product(s) within the ratings.

Recommended Operating Conditions

μPD77110

Parameter	Symbol	Condition	MIN.	TYP.	MAX.	Unit
Operating voltage	IV <sub>DD</sub>	For DSP core	2.3		2.7	V
	EV <sub>DD</sub>	For I/O pins	2.7		3.6	V
Input voltage	V <sub>I</sub>		0		EV <sub>DD</sub>	V

μPD77111, 77112

Parameter	Symbol	Condition	MIN.	TYP.	MAX.	Unit
Operating voltage	IV <sub>DD</sub>	For DSP core	1.8		2.7	V
	EV <sub>DD</sub>	For I/O pins	IV <sub>DD</sub> = 1.8 to 2.7 V		3.3	V
			IV <sub>DD</sub> = 2.3 to 2.7 V		3.6	
Input voltage	V <sub>I</sub>		0		EV <sub>DD</sub>	V

Capacitance (T<sub>A</sub> = +25°C, IV<sub>DD</sub> = 0 V, EV<sub>DD</sub> = 0 V)

Parameter	Symbol	Condition	MIN.	TYP.	MAX.	Unit
Input capacitance	C <sub>I</sub>	f = 1 MHz, Pins other than those tested: 0 V		10		pF
Output capacitance	C <sub>O</sub>			10		pF
I/O capacitance	C <sub>IO</sub>			10		pF



DC Characteristics (T<sub>A</sub> = -40 to +85°C, with IV<sub>DD</sub> and EV<sub>DD</sub> within recommended operating condition range)

Parameter	Symbol	Condition	MIN.	TYP.	MAX.	Unit
High-level input voltage	V <sub>IHN</sub>	Pins other than below	0.7 EV <sub>DD</sub>		EV <sub>DD</sub>	V
	V <sub>IHS</sub>	CLKIN, RESET, INT1 - INT4, SCK1, SIEN1, SOEN1, SCK2, SIEN2, SOEN2	0.8 EV <sub>DD</sub>		EV <sub>DD</sub>	V
Low-level input voltage	V <sub>IL</sub>		0		0.2 EV <sub>DD</sub>	V
High-level output voltage	V <sub>OH</sub>	I <sub>OH</sub> = -2.0 mA	0.7 EV <sub>DD</sub>			V
		I <sub>OH</sub> = -100 μA	0.8 EV <sub>DD</sub>			V
Low-level output voltage	V <sub>OL</sub>	I <sub>OL</sub> = 2.0 mA			0.2 EV <sub>DD</sub>	V
High-level input leakage current	I <sub>LH</sub>	Other than TDI, TMS, and TRST V <sub>i</sub> = EV <sub>DD</sub>	0		10	μA
Low-level input leakage current	I <sub>LL</sub>	Other than TDI, TMS, and TRST V <sub>i</sub> = 0 V	-10		0	μA
Pull-up pin current	I <sub>PUI</sub>	TDI, TMS, 0 V ≤ V <sub>i</sub> ≤ EV <sub>DD</sub>	-250		0	μA
Pull-down pin current	I <sub>PDI</sub>	TRST, 0 V ≤ V <sub>i</sub> ≤ EV <sub>DD</sub>	0		250	μA
Internal supply current [V <sub>IHN</sub> = V <sub>IHS</sub> = EV <sub>DD</sub> , V <sub>IL</sub> = 0 V, no load]	I <sub>DD</sub> <sup>Note 1</sup>	During operating, 30 ns, IV <sub>DD</sub> = 2.7 V		TBD	75	mA
	I <sub>DDH</sub>	In halt mode, t <sub>cC</sub> = 30 ns, divided by eight, IV <sub>DD</sub> = 2.7 V		TBD	10	mA
	I <sub>DDS</sub>	In stop mode, 0°C < T <sub>A</sub> < 60°C			100 <sup>Note 2</sup>	μA

- Notes**
- The TYP. values are when an ordinary program is executed. The MAX. values are when a special program that brings about frequent switching inside the device is executed.
  - Values of μPD77111 and 77112. The parameters of the μPD77110 are still under evaluation.

Common Test Criteria of Switching Characteristics

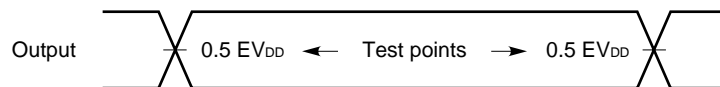
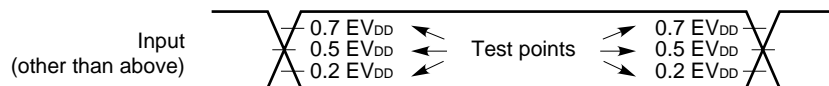
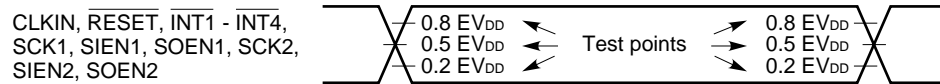

μPD77110

(1) μPD77110 AC Characteristics (Unless otherwise specified, T<sub>A</sub> = -40 to +85°C, with IV<sub>DD</sub> and EV<sub>DD</sub> within recommended operating condition range)

Clock

Timing requirements

Parameter	Symbol	Condition	MIN.	TYP.	MAX.	Unit
★ CLKIN cycle time <sup>Note 1</sup>	t <sub>cCX</sub>		25			ns
		PLL lock range <sup>Note 2</sup>	10 × m		50 × m	ns
CLKIN high-level width	t <sub>wCXH</sub>		12.5			ns
CLKIN low-level width	t <sub>wCXL</sub>		12.5			ns
CLKIN rise/fall time	t <sub>r/cCX</sub>				5	ns
Internal clock cycle time requirements <sup>Note 3</sup>	t <sub>cC (R)</sub>		15.3			ns

Notes 1. m: Multiple

2. This is the range in which the PLL is locked (stably oscillates). Input t<sub>cCX</sub> within this range.

3. Input t<sub>cCX</sub> so that the value of (t<sub>cCX</sub> ÷ m) satisfies this condition.

Timing requirements (T<sub>A</sub> = -40 to +60°C, IV<sub>DD</sub> = 2.5 to 2.7 V, EV<sub>DD</sub> = 2.7 to 3.6 V)

Parameter	Symbol	Condition	MIN.	TYP.	MAX.	Unit
★ CLKIN cycle time <sup>Note 1</sup>	t <sub>cCX</sub>		25			ns
		PLL lock range <sup>Note 2</sup>	10 × m		50 × m	ns
CLKIN high-level width	t <sub>wCXH</sub>		12.5			ns
CLKIN low-level width	t <sub>wCXL</sub>		12.5			ns
CLKIN rise/fall time	t <sub>r/cCX</sub>				5	ns
Internal clock cycle time requirements <sup>Note 2</sup>	t <sub>cC (R)</sub>		13.3			ns

Notes 1. m: Multiple

2. This is the range in which the PLL is locked (stably oscillates). Input t<sub>cCX</sub> within this range.

3. Input t<sub>cCX</sub> so that the value of (t<sub>cCX</sub> ÷ m) satisfies this condition.

Switching characteristics

Parameter	Symbol	Condition	MIN.	TYP.	MAX.	Unit
Internal clock cycle <sup>Note</sup>	$t_{cC}$	During normal operation		$t_{cCX} + m$		ns
		In HALT mode		$t_{cCX} + m \times l$		ns
CLKOUT cycle time	$t_{cCO}$			$t_{cC}$		ns
CLKOUT width	$t_{wCO}$	During normal operation	$t_{cCX} + 2 - 3$			ns
		In HALT mode	$t_{cCX} + m - 3$			ns
CLKOUT rise/fall time	$t_{rCO}$				5	ns
CLKOUT delay time	$t_{dCO}$				15	ns

**Note** m: Multiple, l: HALT division ratio

Clock I/O timing

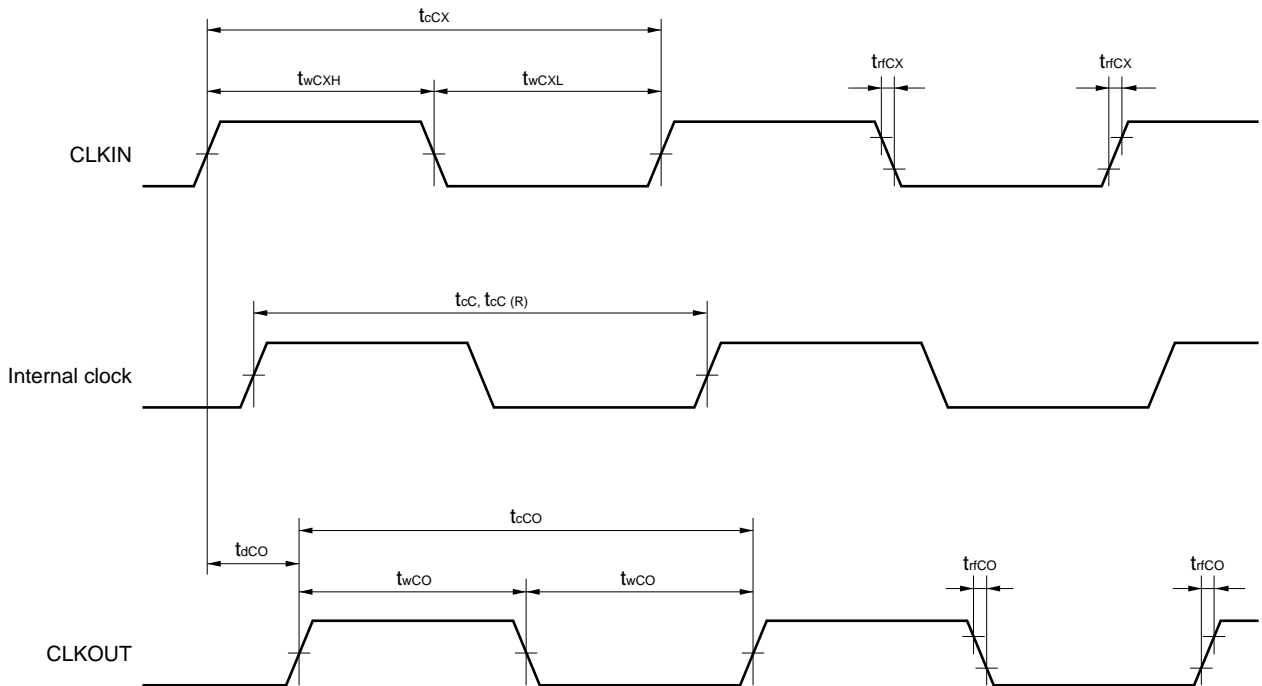

μPD77110

Reset, Interrupt

Timing requirements

Parameter	Symbol	Condition	MIN.	TYP.	MAX.	Unit
★ RESET low-level width	$t_w(RL)$	On power application <sup>Note 1</sup> , in STOP mode	100 + 2048 $t_{cCX}$			μs
		During normal operation, in HALT mode	4 $t_{cC}$ <sup>Note 2</sup>		<b>Note 3</b>	ns
★ RESET recovery time	$t_{rec}(R)$	On power application <sup>Note 4</sup>	4 $t_{cCX}$			ns
			4 $t_{cC}$ <sup>Note 2</sup>			ns
★ WAKEUP low-level width	$t_w(WAKEUPL)$		100			μs
INT1 - INT4 low-level width	$t_w(INTL)$		3 $t_{cC}$ <sup>Note 2</sup>			ns
INT1 - INT4 recovery time	$t_{rec}(INT)$		3 $t_{cC}$			ns

- Notes**
1. The value on power application is the time from when the supply voltages have reached  $IV_{DD} = 1.8 V$  and  $EV_{DD} = 2.7 V$ . A stable clock input is also required.
  2. Note that  $t_{cC}$  is eight times this value during normal operation in the HALT mode.
  3. If the low-level width of RESET is greater than  $1024t_{cC}$ , the PLL initialization mode is triggered. If there is no need to use the PLL initialization mode, set the width to less than  $1024t_{cC}$ .
  4. When the power is turned on, a recovery period of  $4t_{cCX}$  is necessary before inputting RESET.

Reset timing

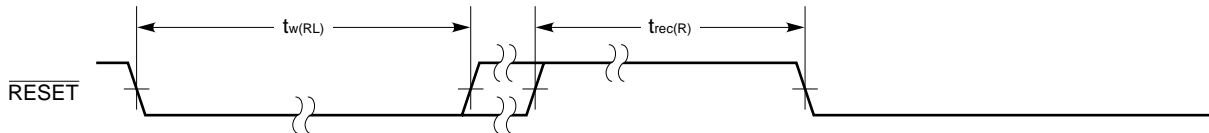

★ WAKEUP timing

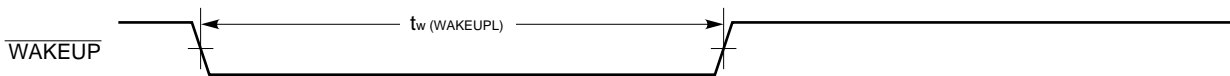

Interrupt timing

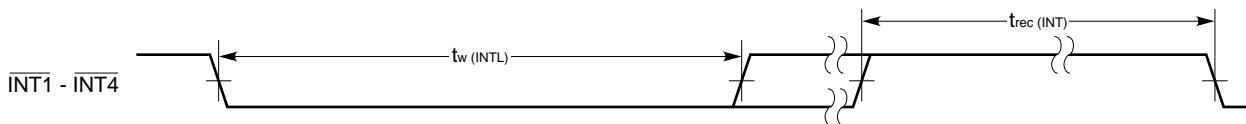

**External Data Memory Access**

**Timing requirements**

Parameter	Symbol	Condition	MIN.	TYP.	MAX.	Unit
Read data setup time	$t_{suDDR}$		18			ns
Read data hold time	$t_{hDDR}$		0			ns

**Switching characteristics**

Parameter	Symbol	Condition	MIN.	TYP.	MAX.	Unit
Address cycle time	$t_{cDA}$			$t_{cC} + (t_{cC} \times t_{cDW})^{Note}$		ns
Address output hold time	$t_{hDA}$		0			ns
M $\overline{RD}$ output delay time	$t_{dDR}$				5	ns
Write data output valid time	$t_{vDDWD}$				5	ns
Write data output hold time	$t_{hDDWD}$		0			ns
M $\overline{WR}$ output delay time	$t_{dDW}$		0		0.5 $t_{cC}$	ns
M $\overline{WR}$ output hold time	$t_{hDA}$		0			ns
M $\overline{WR}$ low-level width	$t_{wDWL}$		$t_{cC} \times t_{cDW} - 3$			ns
M $\overline{WR}$ high-level width	$t_{wDWH}$		0.5 $t_{cC} - 3$			ns

**Note**  $t_{cDW}$ : Number of data wait cycles

$\mu$ PD77110

External data memory access timing (read)

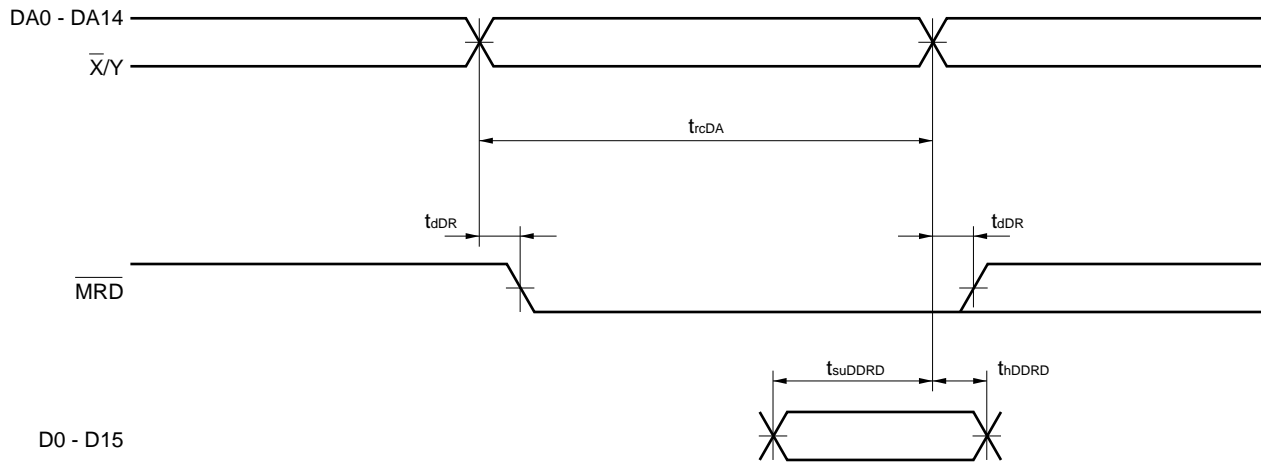

External data memory access timing (write)

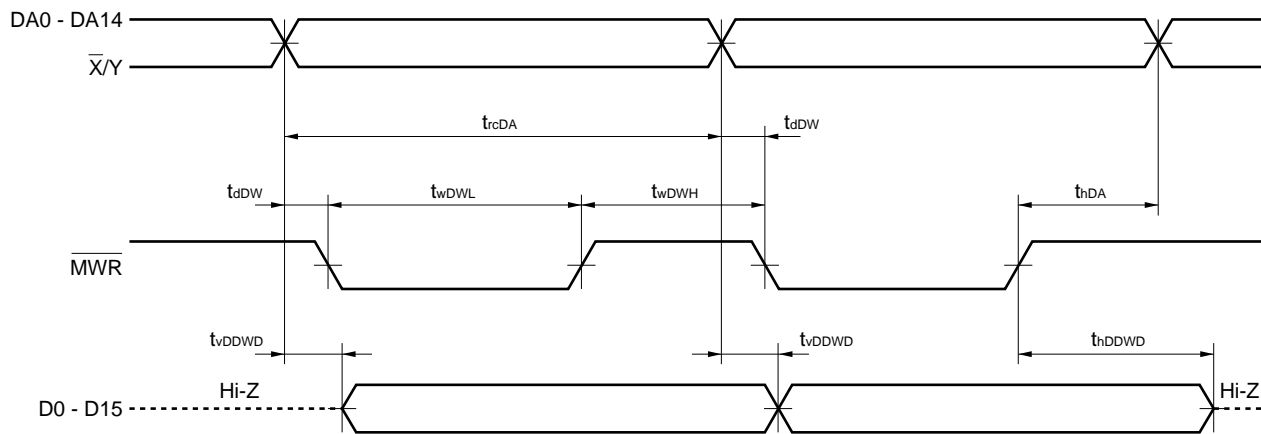

**Bus Arbitration**

**Timing requirements**

Parameter	Symbol	Condition	MIN.	TYP.	MAX.	Unit
HOLDRQ setup time	t <sub>suHRQ</sub>		0			ns
HOLDRQ hold time	t <sub>hHRQ</sub>		0			ns

**Switching characteristics**

Parameter	Symbol	Condition	MIN.	TYP.	MAX.	Unit
BSTB hold time	t <sub>hBS</sub>		0			ns
BSTB output delay time	t <sub>dBS</sub>				20	ns
HOLDAK output delay time	t <sub>dHAK</sub>				18	ns
Data hold time during bus arbitration	t <sub>h (BS-D)</sub>				25	ns
Data valid time during bus arbitration	t <sub>v (BS-D)</sub>				25	ns

μPD77110

**Bus arbitration timing (when bus is idle)**

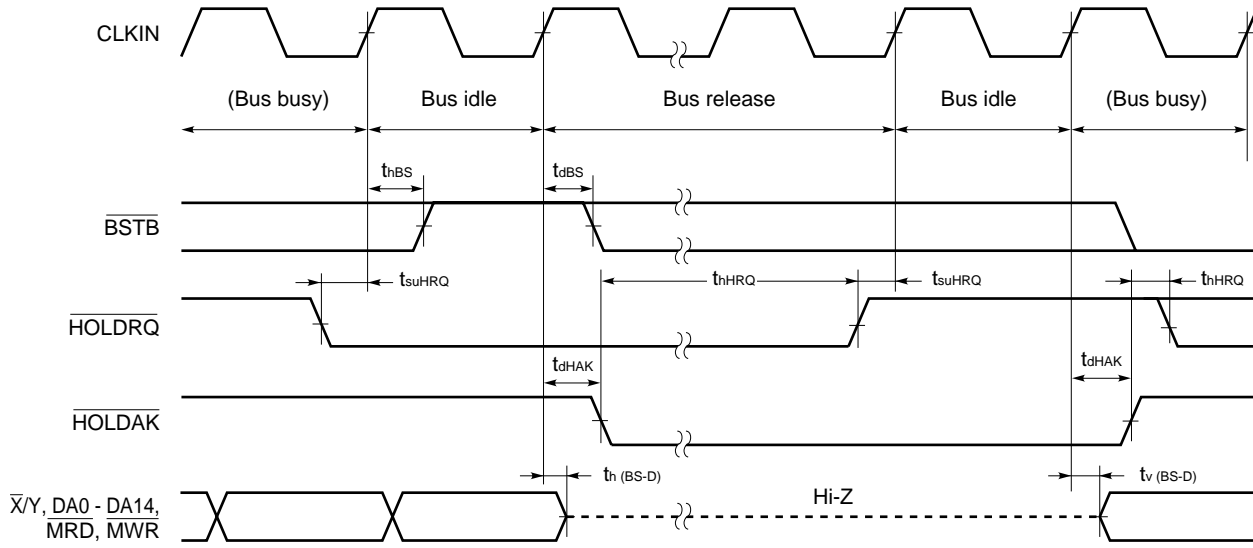

**Bus arbitration timing (when bus is busy)**

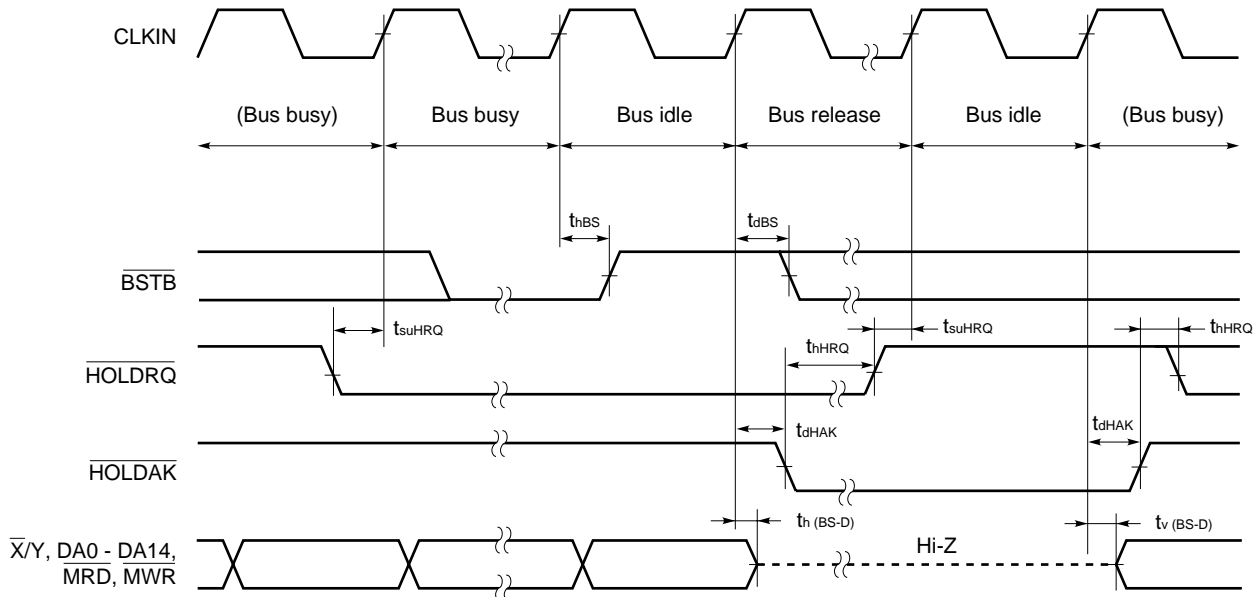



**Serial Interface**

**Timing requirements**

Parameter	Symbol	Condition	MIN.	TYP.	MAX.	Unit
SCK cycle time	$t_{SC}$		60			ns
SCK high-/low-level width	$t_{WSC}$		25			ns
SCK rise/fall time	$t_{rsc}$				20	ns
SOEN setup time	$t_{suSOE}$		5			ns
SOEN hold time	$t_{hSOE}$		10			ns
SIEN setup time	$t_{suSIE}$		5			ns
SIEN hold time	$t_{hSIE}$		10			ns
SI setup time	$t_{suSI}$		5			ns
SI hold time	$t_{hSI}$		10			ns

**Switching characteristics**

Parameter	Symbol	Condition	MIN.	TYP.	MAX.	Unit
SORQ output delay time	$t_{dSOR}$				25	ns
SORQ hold time	$t_{hSOR}$		0			ns
SO output delay time	$t_{dSO}$				25	ns
SO hold time	$t_{hSO}$		0			ns
SI AK output delay time	$t_{dSIA}$				25	ns
SI AK hold time	$t_{hSIA}$		0			ns

**Caution** If noise is superimposed on the serial clock, the serial interface may be deadlocked. Bear in mind the following points when designing your system:

- Reinforce the wiring for power supply and ground (if noise is superimposed on the power and ground lines, it has the same effect as if noise were superimposed on the serial clock).
- Shorten the wiring between the device's SCK1 and SCK2 pins, and clock supply source.
- Do not cross the signal lines of the serial clock with any other signal lines. Do not route the serial clock line in the vicinity of a line through which a high alternating current flows.
- Supply the clock to the SCK1 and SCK2 pins of the device from the clock source on a one-to-one basis. Do not supply clock to several devices from one clock source.
- Exercise care that the serial clock does not overshoot or undershoot. In particular, make sure that the rising and falling of the serial clock waveform are clear.

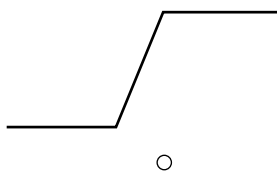

○

Make sure that the serial clock rises and falls linearly.



×

The serial clock must not bound. Noise must not be superimposed on the serial clock.

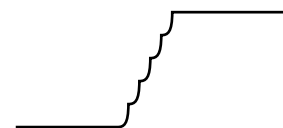

×

The serial clock must not rise or fall step-wise.

μPD77110

Serial output timing 1

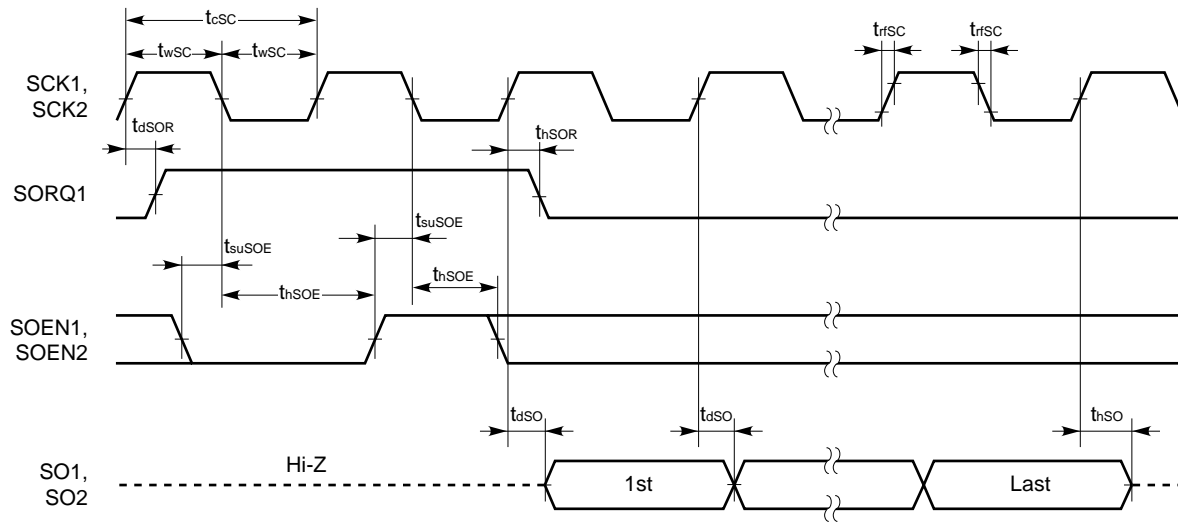

Serial output timing 2 (during successive output)

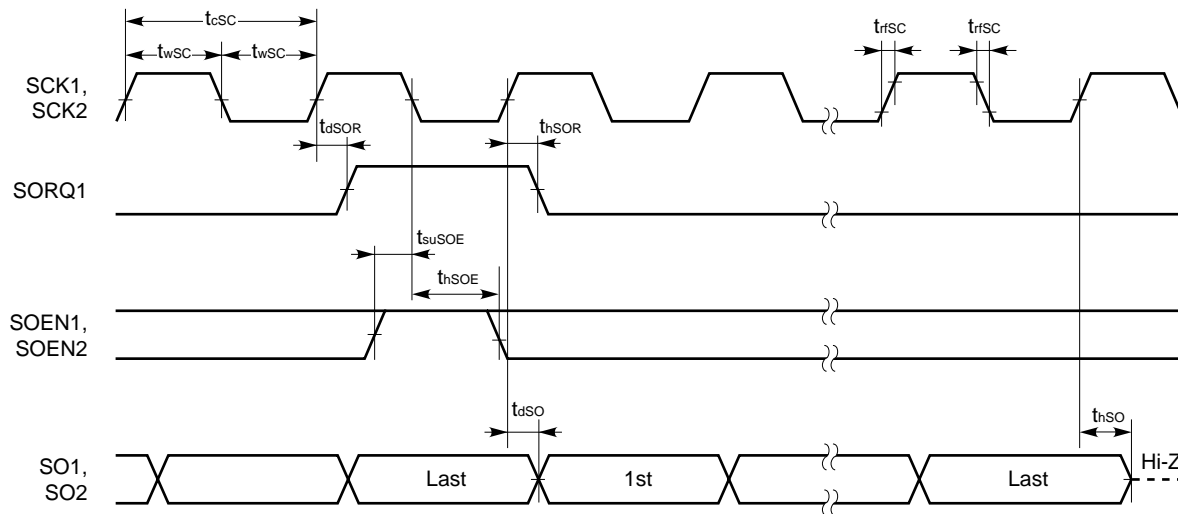

Serial input timing 1

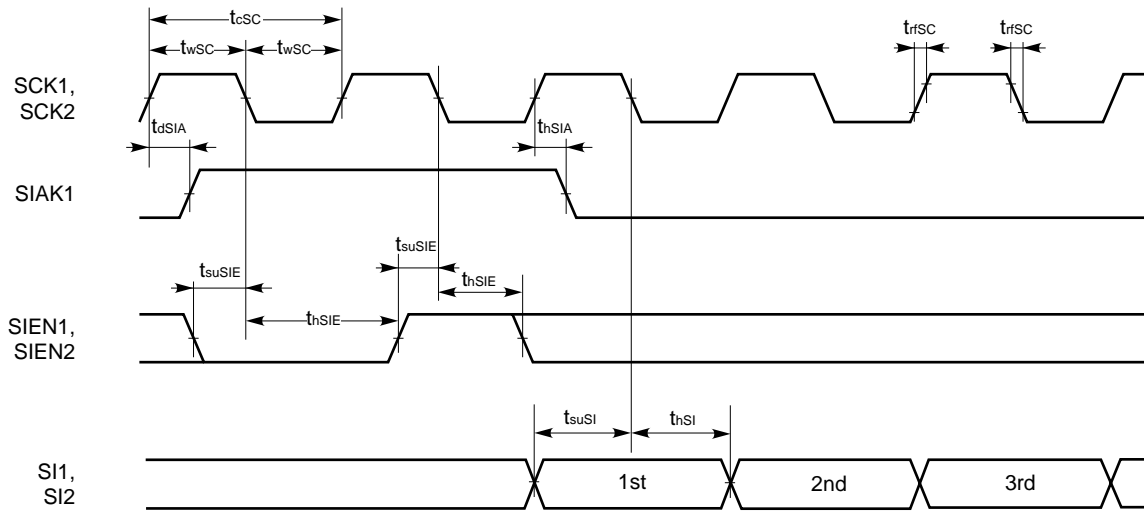

Serial input timing 2 (during successive input)

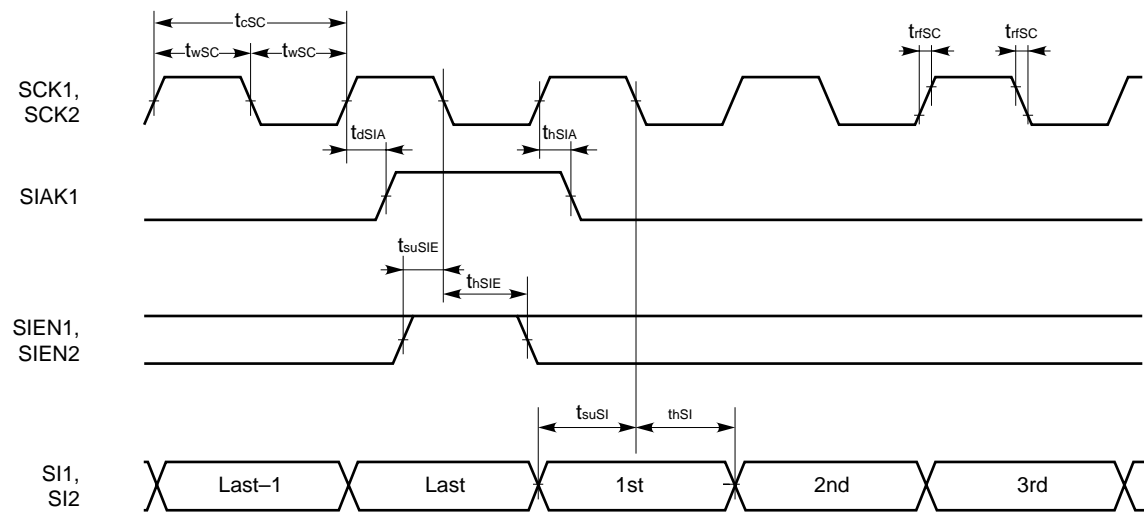

μPD77110

**Host Interface**

**Timing requirements**

Parameter	Symbol	Condition	MIN.	TYP.	MAX.	Unit
$\overline{\text{HRD}}$ delay time	$t_{dHR}$		10			ns
$\overline{\text{HRD}}$ width	$t_{wHR}$		60			ns
$\overline{\text{HCS}}$ , HA0, HA1, read hold time	$t_{hCAR}$		0			ns
HCS, HA0, HA1 line hold time	$t_{hCAW}$		0			ns
$\overline{\text{HRD}}$ , $\overline{\text{HWR}}$ recovery time	$t_{recHS}$		60			ns
$\overline{\text{HWR}}$ delay time	$t_{dHW}$		10			ns
$\overline{\text{HWR}}$ width	$t_{wHW}$		60			ns
$\overline{\text{HWR}}$ hold time	$t_{hHDW}$		0			ns
$\overline{\text{HWR}}$ setup time	$t_{suHDW}$		10			ns

**Switching characteristics**

Parameter	Symbol	Condition	MIN.	TYP.	MAX.	Unit
$\overline{\text{HRE}}$ , $\overline{\text{HWE}}$ output delay time	$t_{dHE}$				25	ns
$\overline{\text{HRE}}$ , $\overline{\text{HWE}}$ hold time	$t_{hHE}$				25	ns
$\overline{\text{HRD}}$ valid time	$t_{vHDR}$				25	ns
$\overline{\text{HRD}}$ hold time	$t_{hHDR}$		0			ns

Host read interface timing

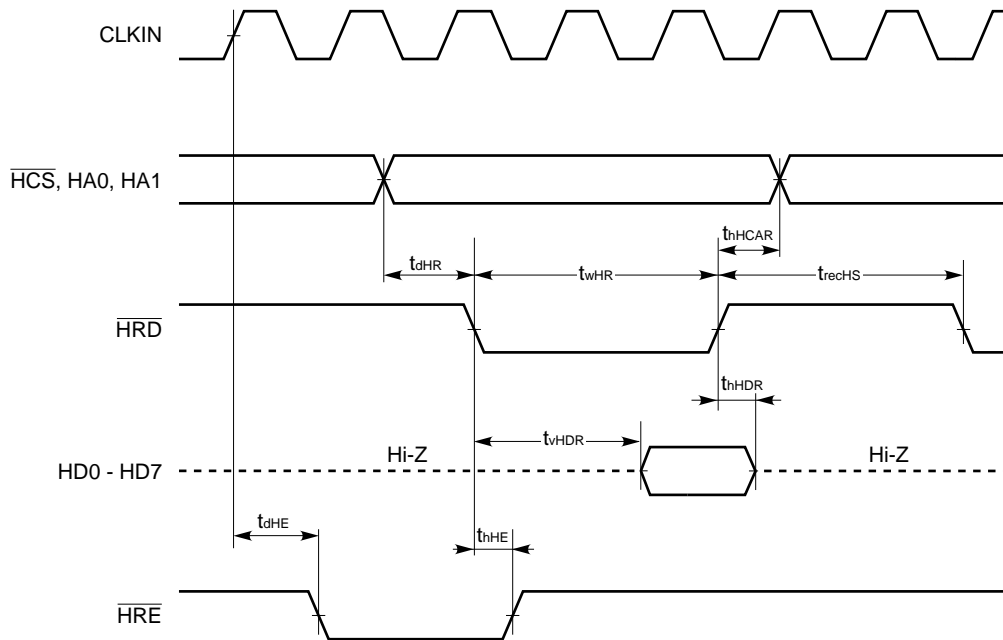

Host write interface timing

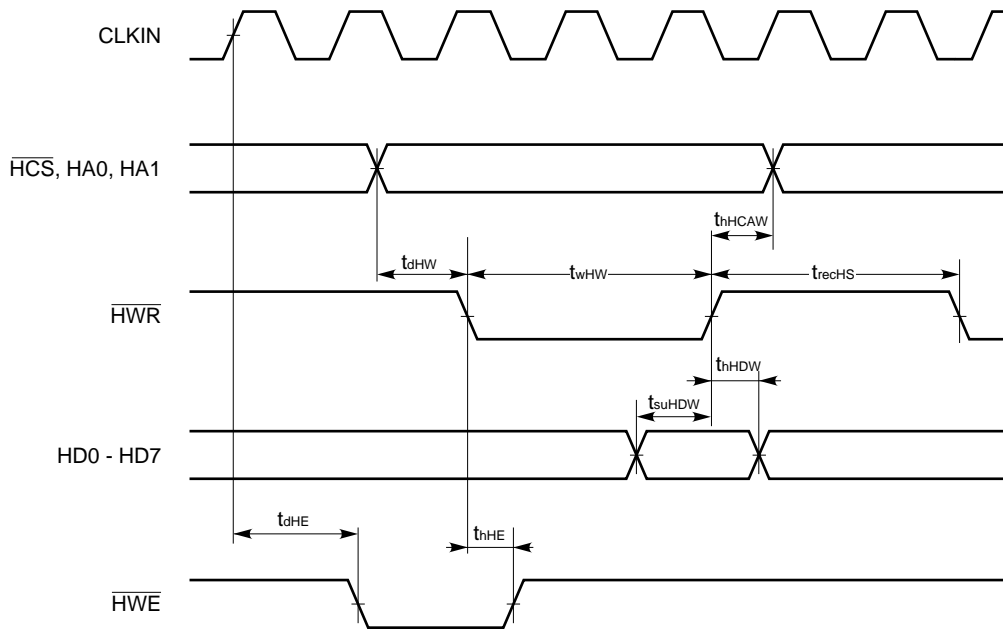

μPD77110

General-purpose I/O Port

Timing requirements

Parameter	Symbol	Condition	MIN.	TYP.	MAX.	Unit
Port input setup time	$t_{suPI}$		0			ns
Port input hold time	$t_{hPI}$		10			ns

Switching characteristics

Parameter	Symbol	Condition	MIN.	TYP.	MAX.	Unit
Port output delay time	$t_{dPO}$				25	ns

General-purpose I/O port timing

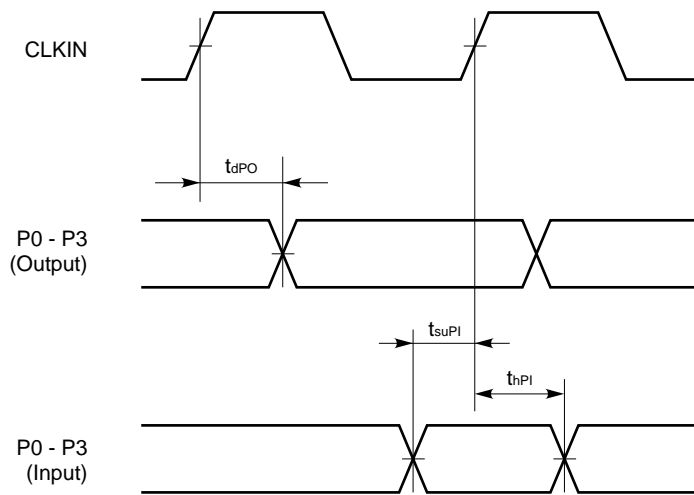

Debugging Interface (JTAG)

Timing requirements

Parameter	Symbol	Condition	MIN.	TYP.	MAX.	Unit
TCK cycle time	$t_{cTCK}$		120			ns
TCK high-/low-level width	$t_{wTCK}$		50			ns
TCK rise/fall time	$t_{rTCK}$				20	ns
TMS, TDI setup time	$t_{suDI}$		20			ns
TMS, TDI hold time	$t_{hDI}$		20			ns
Input pin setup time	$t_{suJIN}$		20			ns
Input pin hold time	$t_{hJIN}$		20			ns
$\overline{TRST}$ setup time	$t_{suTRST}$		100			ns

Switching characteristics

Parameter	Symbol	Condition	MIN.	TYP.	MAX.	Unit
TDO output delay time	$t_{dDO}$				20	ns
Output pin output delay time	$t_{dJOUT}$				20	ns

Debugging interface timing

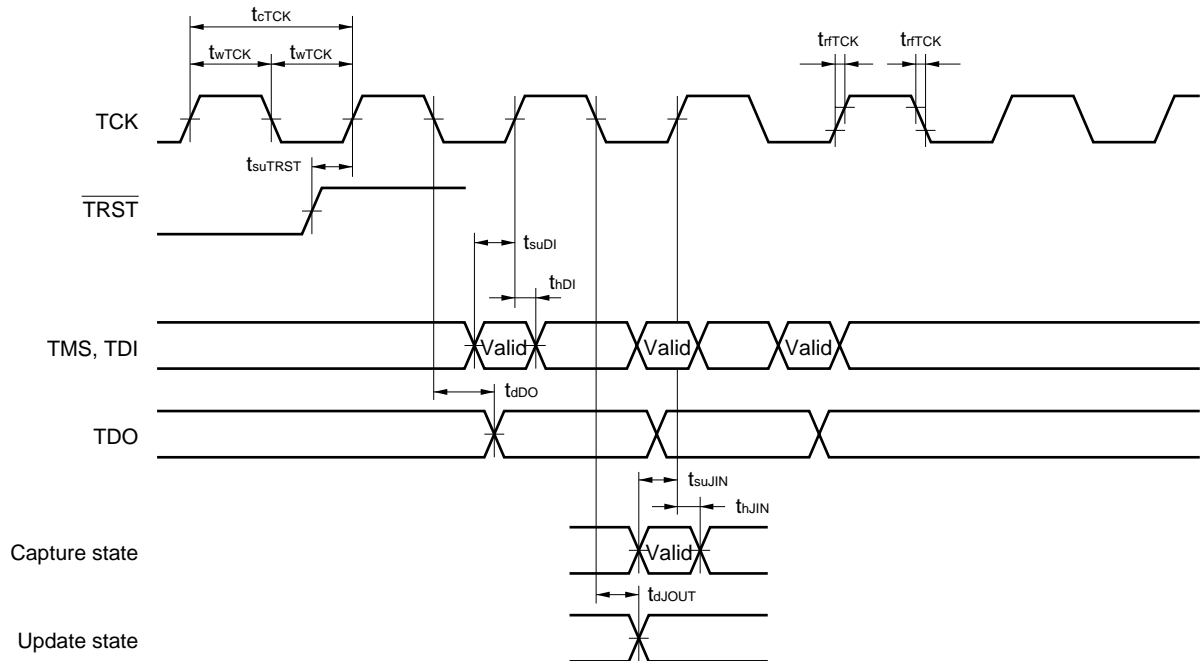

**Remark** For details of JTAG, refer to IEEE1149.1.

μPD77111, 77112

(2) μPD77111, 77112 AC Characteristics (T<sub>A</sub> = -40 to +85°C, with IV<sub>DD</sub> and EV<sub>DD</sub> within recommended operating condition range)

Clock

Timing requirements

Parameter	Symbol	Condition	MIN.	TYP.	MAX.	Unit	
★ CLKIN cycle time <sup>Note 1</sup>	t <sub>cCX</sub>		25			ns	
		PLL lock range <sup>Note 2</sup>	IV <sub>DD</sub> = 1.8 to 2.7 V	25 × m		50 × m	ns
			IV <sub>DD</sub> = 2.3 to 2.7 V	10 × m		50 × m	ns
CLKIN high-level width	t <sub>wCXH</sub>		12.5			ns	
CLKIN low-level width	t <sub>wCXL</sub>		12.5			ns	
CLKIN rise/fall time	t <sub>rCX</sub>				5	ns	
Internal clock cycle time requirements <sup>Note 3</sup>	t <sub>cC (R)</sub>	IV <sub>DD</sub> = 1.8 to 2.7 V	25			ns	
		IV <sub>DD</sub> = 2.3 to 2.7 V	13.3			ns	

- Notes**
1. m: Multiple, n: Division ratio
  2. This is the range in which the PLL is locked (stably oscillates). Input t<sub>cCX</sub> within this range.
  3. Input t<sub>cCX</sub> so that the value of (t<sub>cCX</sub> ÷ m × n) satisfies this condition.

Switching characteristics

Parameter	Symbol	Condition	MIN.	TYP.	MAX.	Unit
Internal clock cycle <sup>Note</sup>	t <sub>cC</sub>	During normal operation		t <sub>cCX</sub> × n ÷ m		ns
		In HALT mode		t <sub>cCX</sub> × n ÷ m × l		ns
CLKOUT cycle time	t <sub>cCO</sub>			t <sub>cC</sub>		ns
CLKOUT width	t <sub>wCO</sub>	During normal operation	n = 1, or even number	t <sub>cCX</sub> ÷ 2 - 3		ns
			n = odd number (other than 1)	t <sub>cCX</sub> ÷ m - 3		ns
		In HALT mode	t <sub>cCX</sub> + m × n - 3		ns	
CLKOUT rise/fall time	t <sub>rCO</sub>				5	ns
CLKOUT delay time	t <sub>dCO</sub>	IV <sub>DD</sub> = 1.8 to 2.7 V			20	ns
		IV <sub>DD</sub> = 2.3 to 2.7 V			15	ns

**Note** m: Multiple, n: Division ratio, l: HALT division ratio



Clock I/O timing

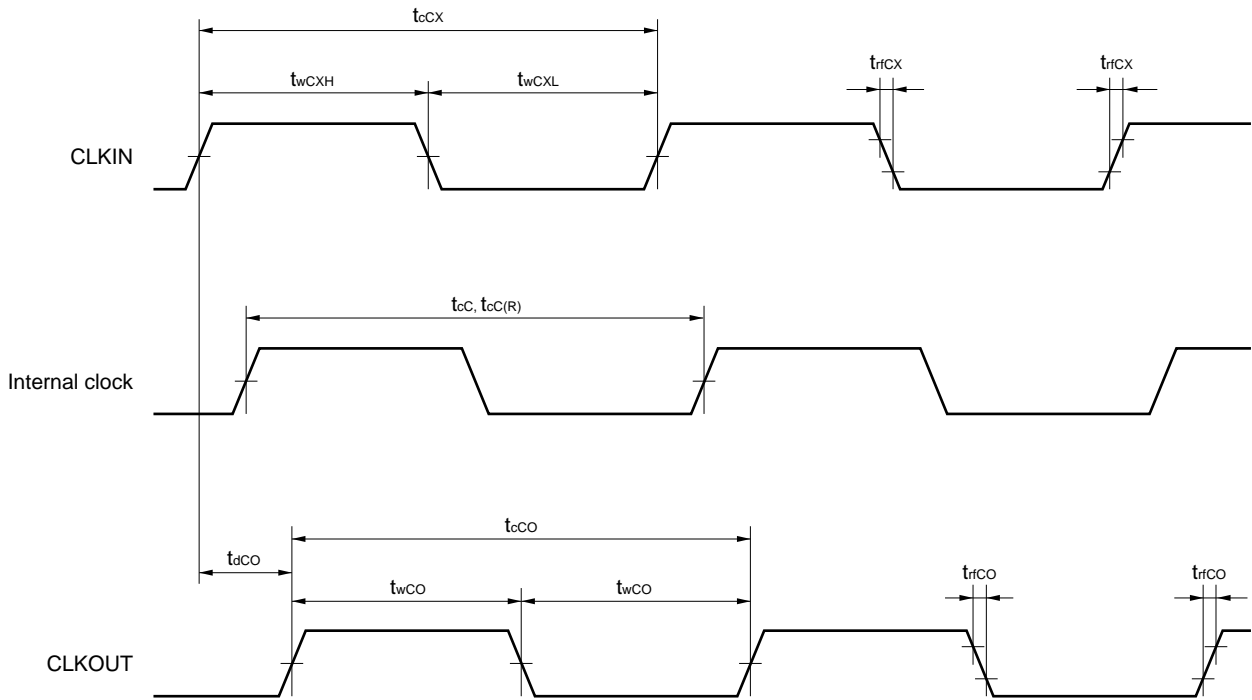

Reset, Interrupt

Timing requirements

Parameter	Symbol	Condition	MIN.	TYP.	MAX.	Unit
★ $\overline{\text{RESET}}$ low-level width	$t_{w(RL)}$	On power application <sup>Note 1</sup> , in STOP mode	100 + 2048 $t_{cCX}$			μs
		During normal operation, in HALT mode	4 $t_{cC}$ <sup>Note 2</sup>		<b>Note 3</b>	ns
★ $\overline{\text{RESET}}$ recovery time	$t_{rec(R)}$	On power application <sup>Note 4</sup>	4 $t_{cCX}$			ns
			4 $t_{cC}$ <sup>Note 2</sup>			ns
★ $\overline{\text{WAKEUP}}$ low-level width	$t_{w(WAKEUPL)}$		100			μs
$\overline{\text{INT1}} - \overline{\text{INT4}}$ low-level width	$t_{w(INTL)}$		3 $t_{cC}$ <sup>Note 2</sup>			ns
$\overline{\text{INT1}} - \overline{\text{INT4}}$ recovery time	$t_{rec(INT)}$		3 $t_{cC}$			ns

- Notes**
1. The value on power application is the time from when the supply voltages have reached  $IV_{DD} = 1.8\text{ V}$  and  $EV_{DD} = 2.7\text{ V}$ . A stable clock input is also required.
  2. Note that  $t_{cC}$  is  $I$  ( $I = \text{integer of } 1 \text{ to } 16$ ) times that during normal operation in the HALT mode.
  3. If the low-level width of  $\overline{\text{RESET}}$  is greater than  $1024t_{cC}$ , the PLL initialization mode is triggered. If there is no need to use the PLL initialization mode, set the width to less than  $1024t_{cC}$ .
  4. When the power is turned on, a recovery period of  $4t_{cCX}$  is necessary before inputting  $\overline{\text{RESET}}$ .

Reset timing

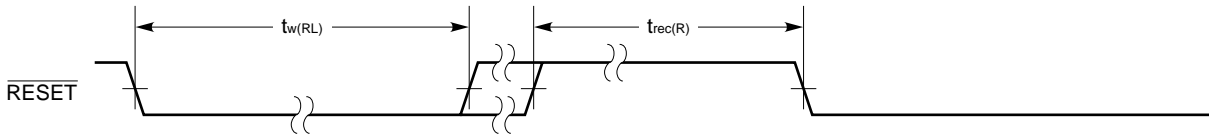

★ WAKEUP timing

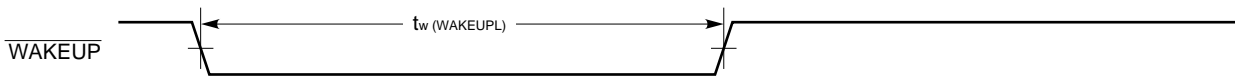

Interrupt timing

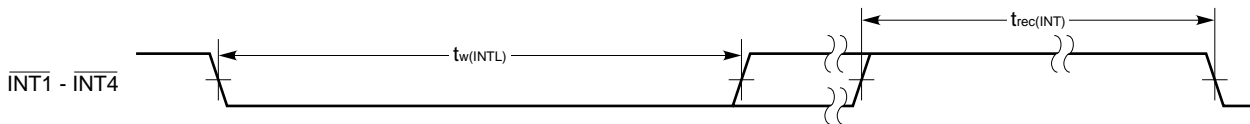

External Data Memory Access (μPD77112 only)

Timing requirements

Parameter	Symbol	Condition	MIN.	TYP.	MAX.	Unit
Read data setup time	$t_{suDDR}$		18			ns
Read data hold time	$t_{hDDR}$		0			ns

Switching characteristics

Parameter	Symbol	Condition	MIN.	TYP.	MAX.	Unit
Address cycle time	$t_{cDA}$			$t_{cC} + (t_{cD} \times t_{cDW})^{Note}$		ns
Address output hold time	$t_{hDA}$		0			ns
$\overline{MRD}$ output delay time	$t_{dDR}$				5	ns
Write data output valid time	$t_{vDDWD}$				5	ns
Write data output hold time	$t_{hDDWD}$		0			ns
$\overline{MWR}$ output delay time	$t_{dDW}$		0		0.5 $t_{cC}$	ns
$\overline{MWR}$ output hold time	$t_{hDA}$		0			ns
$\overline{MWR}$ low-level width	$t_{wDWL}$		$t_{cC} \times t_{cDW} - 3$			ns
$\overline{MWR}$ high-level width	$t_{wDWH}$		0.5 $t_{cC} - 3$			ns

**Note**  $t_{cDW}$ : Number of data wait cycles

μPD77111, 77112

External data memory access timing (read)

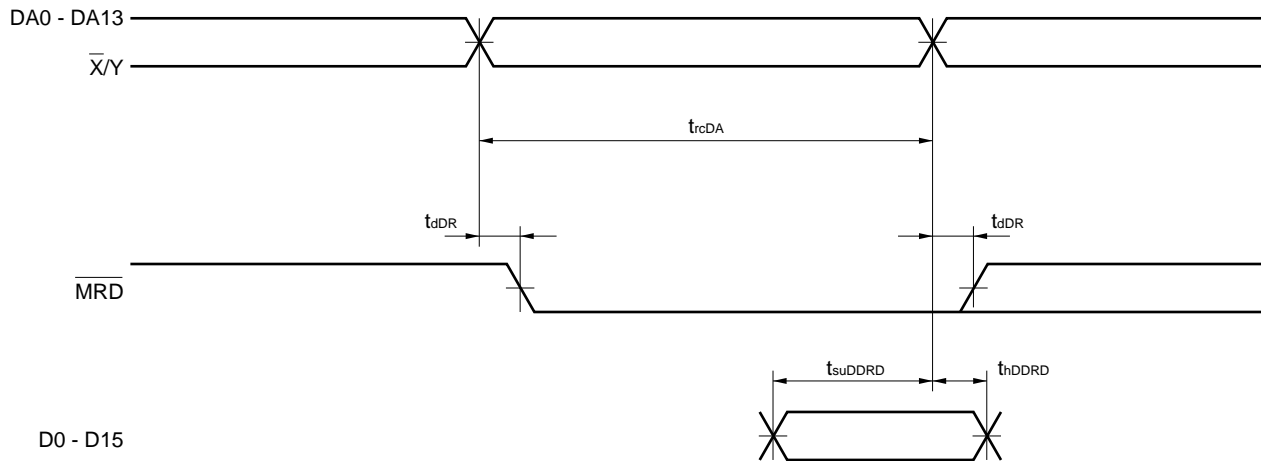

External data memory access timing (write)

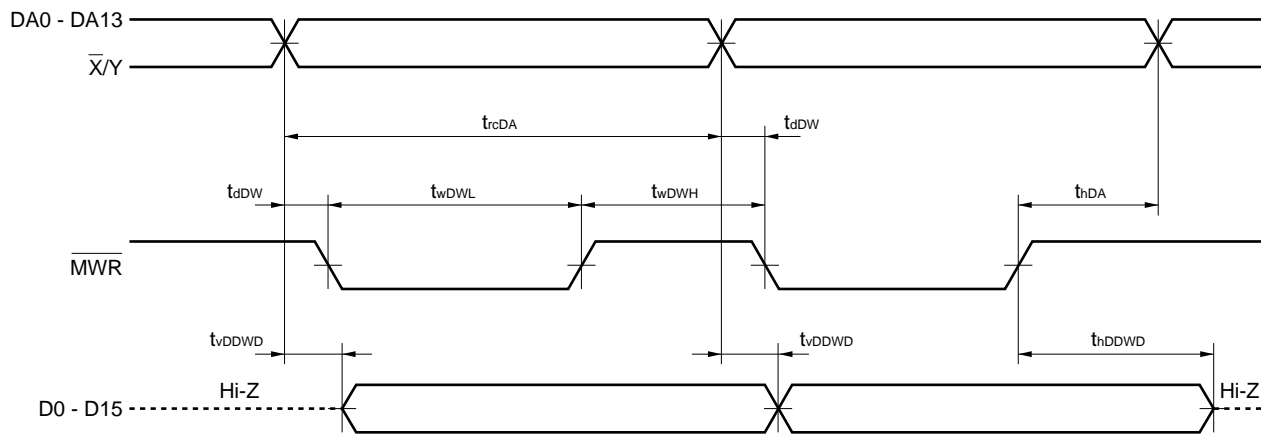

**Bus Arbitration (μPD77112 only)**

**Timing requirements**

Parameter	Symbol	Condition	MIN.	TYP.	MAX.	Unit
HOLDRQ setup time	t <sub>suHRQ</sub>		0			ns
HOLDRQ hold time	t <sub>hHRQ</sub>		0			ns

**Switching characteristics**

Parameter	Symbol	Condition	MIN.	TYP.	MAX.	Unit
BSTB hold time	t <sub>hBS</sub>		0			ns
BSTB output delay time	t <sub>dBS</sub>				20	ns
HOLDAK output delay time	t <sub>dHAK</sub>				18	ns
Data hold time during bus arbitration	t <sub>h (BS-D)</sub>				25	ns
Data valid time during bus arbitration	t <sub>v (BS-D)</sub>				25	ns

μPD77111, 77112

**Bus arbitration timing (when bus is idle)**

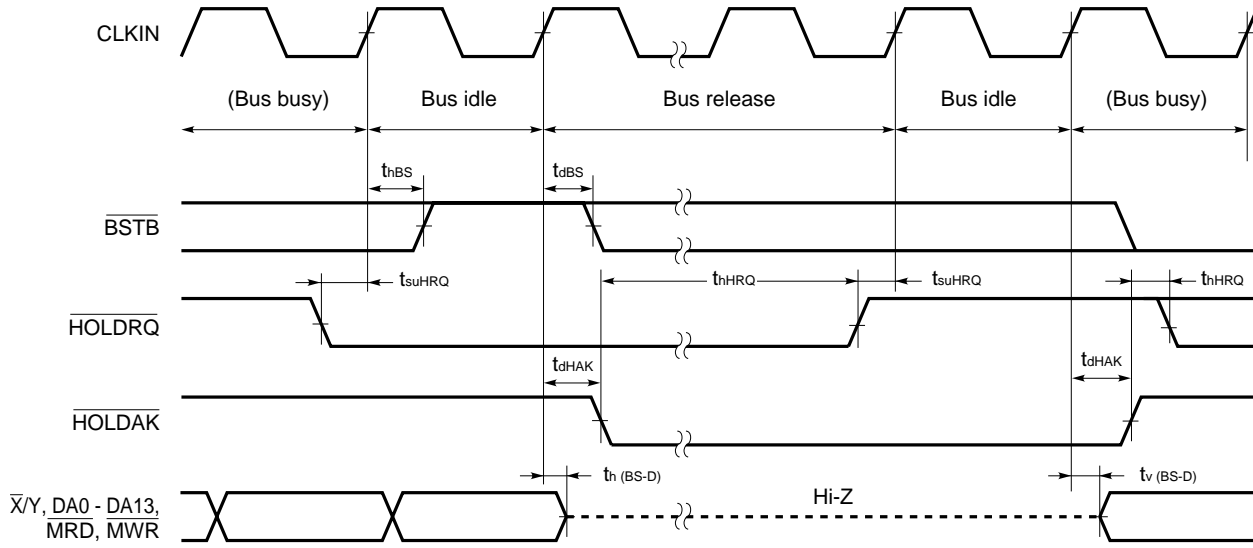

**Bus arbitration timing (when bus is busy)**

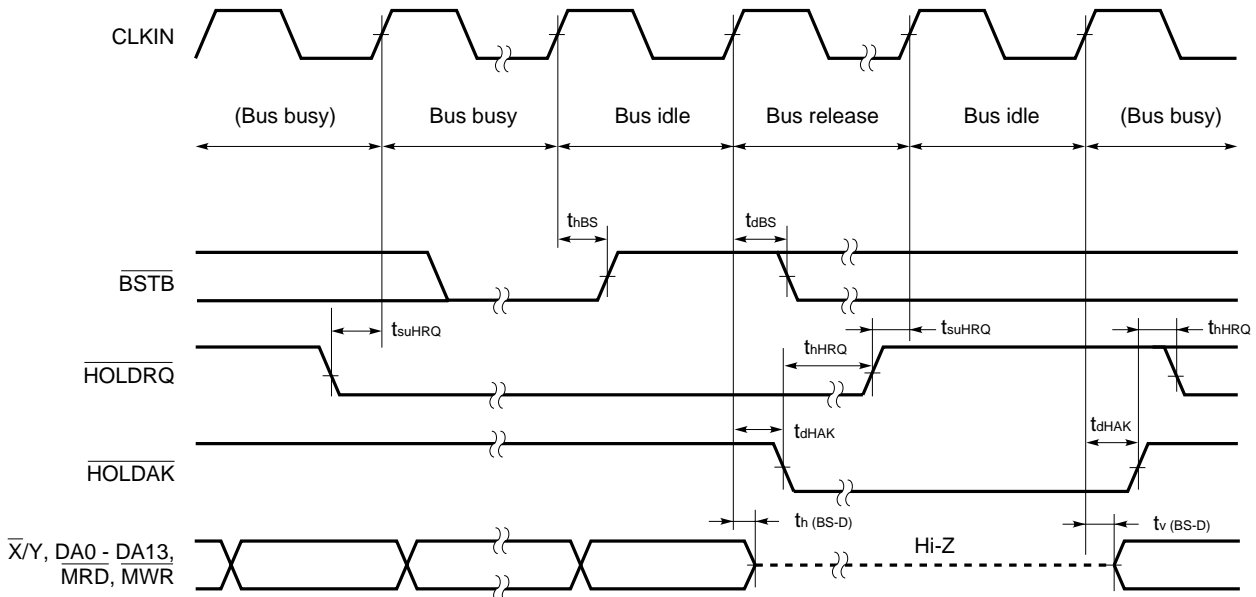

Serial Interface

Timing requirements

Parameter	Symbol	Condition	MIN.	TYP.	MAX.	Unit
SCK cycle time	$t_{SC}$		60			ns
SCK high-/low-level width	$t_{WSC}$		25			ns
SCK rise/fall time	$t_{rsc}$				20	ns
SOEN setup time	$t_{suSOE}$	$IV_{DD} = 1.8 \text{ to } 2.7 \text{ V}$	10			ns
		$IV_{DD} = 2.3 \text{ to } 2.7 \text{ V}$	5			ns
SOEN hold time	$t_{hSOE}$	$IV_{DD} = 1.8 \text{ to } 2.7 \text{ V}$	15			ns
		$IV_{DD} = 2.3 \text{ to } 2.7 \text{ V}$	10			ns
SIEN setup time	$t_{suSIE}$	$IV_{DD} = 1.8 \text{ to } 2.7 \text{ V}$	10			ns
		$IV_{DD} = 2.3 \text{ to } 2.7 \text{ V}$	5			ns
SIEN hold time	$t_{hSIE}$	$IV_{DD} = 1.8 \text{ to } 2.7 \text{ V}$	15			ns
		$IV_{DD} = 2.3 \text{ to } 2.7 \text{ V}$	10			ns
SI setup time	$t_{suSI}$	$IV_{DD} = 1.8 \text{ to } 2.7 \text{ V}$	10			ns
		$IV_{DD} = 2.3 \text{ to } 2.7 \text{ V}$	5			ns
SI hold time	$t_{hSI}$	$IV_{DD} = 1.8 \text{ to } 2.7 \text{ V}$	15			ns
		$IV_{DD} = 2.3 \text{ to } 2.7 \text{ V}$	10			ns

Switching characteristics

Parameter	Symbol	Condition	MIN.	TYP.	MAX.	Unit
SORQ output delay time	$t_{dSOR}$	$IV_{DD} = 1.8 \text{ to } 2.7 \text{ V}$			30	ns
		$IV_{DD} = 2.3 \text{ to } 2.7 \text{ V}$			25	ns
SORQ hold time	$t_{hSOR}$		0			ns
SO output delay time	$t_{dSO}$	$IV_{DD} = 1.8 \text{ to } 2.7 \text{ V}$			30	ns
		$IV_{DD} = 2.3 \text{ to } 2.7 \text{ V}$			25	ns
SO hold time	$t_{hSO}$		0			ns
SIAM output delay time	$t_{dSIA}$	$IV_{DD} = 1.8 \text{ to } 2.7 \text{ V}$			30	ns
		$IV_{DD} = 2.3 \text{ to } 2.7 \text{ V}$			25	ns
SIAM hold time	$t_{hSIA}$		0			ns

μPD77111, 77112

**Caution** If noise is superimposed on the serial clock, the serial interface may be deadlocked. Bear in mind the following points when designing your system:

- Reinforce the wiring for power supply and ground (if noise is superimposed on the power and ground lines, it has the same effect as if noise were superimposed on the serial clock).
- Shorten the wiring between the device's SCK1 and SCK2 pins, and clock supply source.
- Do not cross the signal lines of the serial clock with any other signal lines. Do not route the serial clock line in the vicinity of a line through which a high alternating current flows.
- Supply the clock to the SCK1 and SCK2 pins of the device from the clock source on a one-to-one basis. Do not supply clock to several devices from one clock source.
- Exercise care that the serial clock does not overshoot or undershoot. In particular, make sure that the rising and falling of the serial clock waveform are clear.

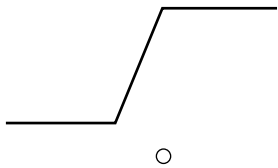

Make sure that the serial clock rises and falls linearly.

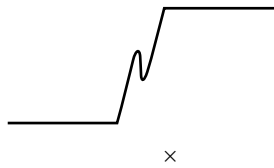

The serial clock must not bound. Noise must not be superimposed on the serial clock.

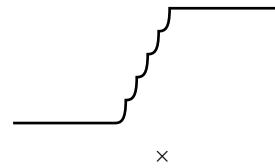

The serial clock must not rise or fall step-wise.



**Serial output timing 1**

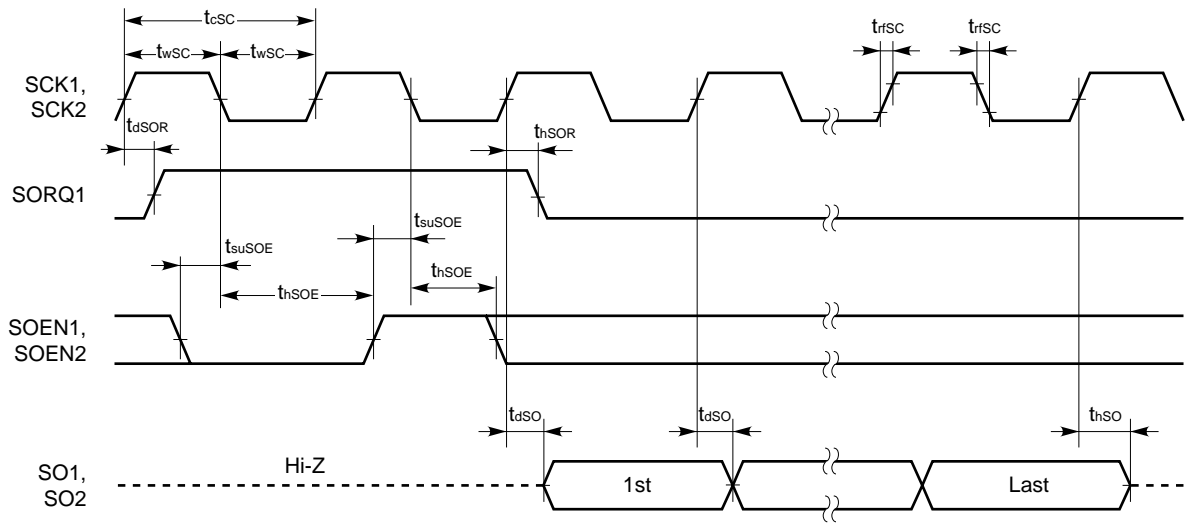

**Serial output timing 2 (during successive output)**

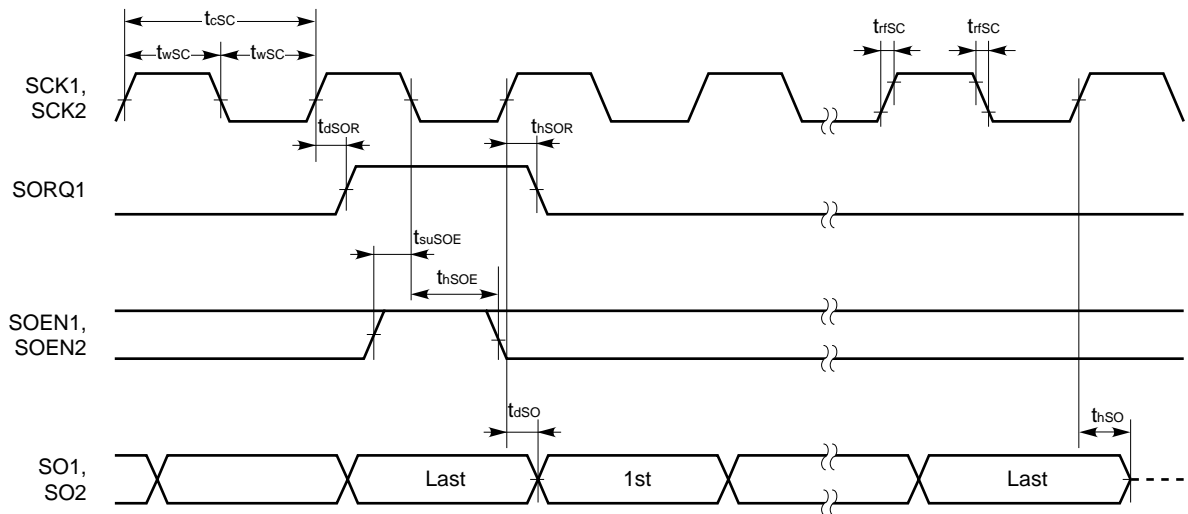

$\mu$ PD77111, 77112

Serial input timing 1

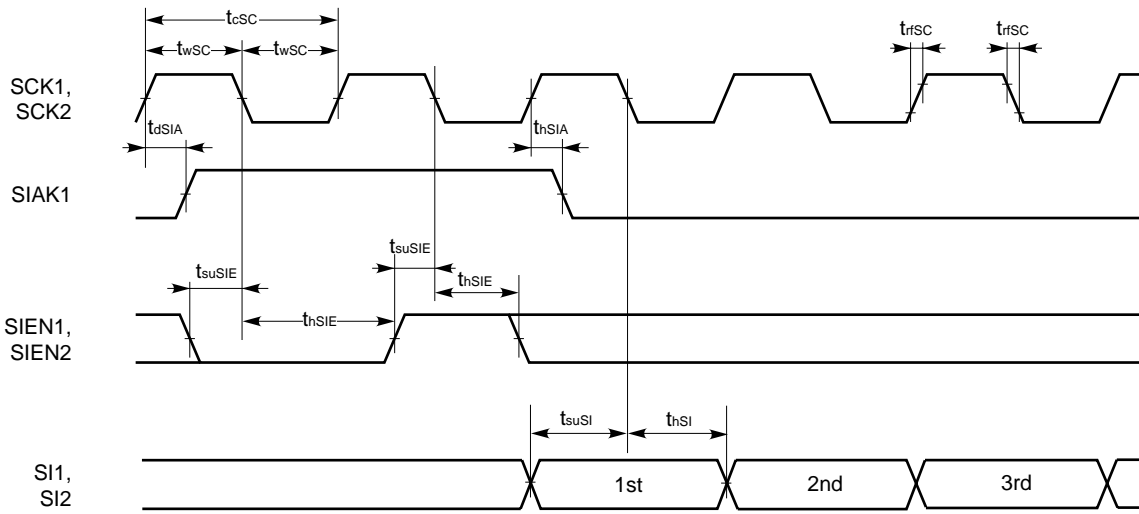

Serial input timing 2 (during successive input)

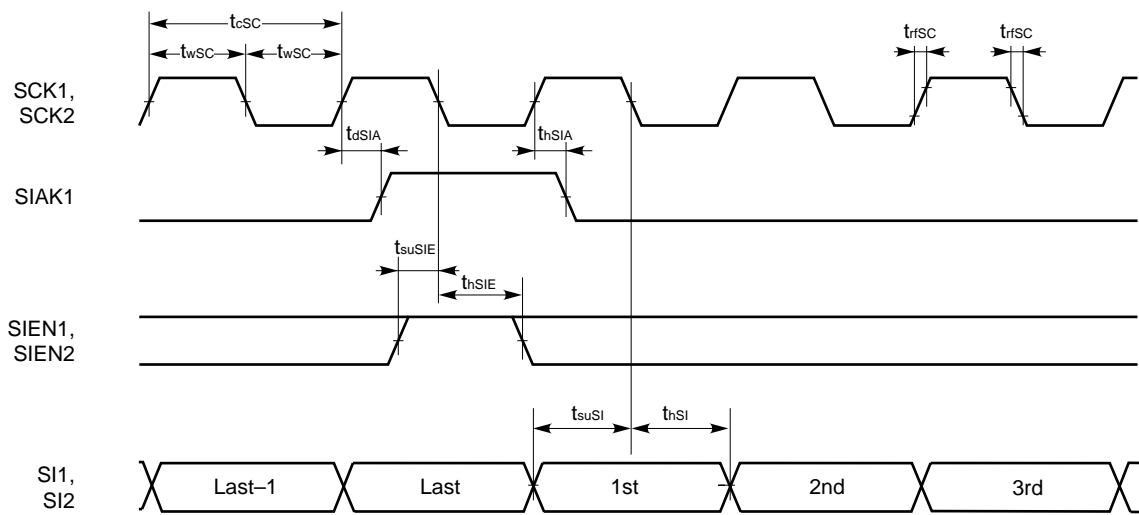

Host Interface

Timing requirements

Parameter	Symbol	Condition	MIN.	TYP.	MAX.	Unit
$\overline{\text{HRD}}$ delay time	$t_{\text{dHR}}$	$V_{\text{DD}} = 1.8 \text{ to } 2.7 \text{ V}$	15			ns
		$V_{\text{DD}} = 2.3 \text{ to } 2.7 \text{ V}$	10			ns
$\overline{\text{HRD}}$ width	$t_{\text{wHR}}$		60			ns
HCS, HA0, HA1, read hold time	$t_{\text{hCAR}}$		0			ns
HCS, HA0, HA1 line hold time	$t_{\text{hCAW}}$		0			ns
$\overline{\text{HRD}}$ , $\overline{\text{HWR}}$ recovery time	$t_{\text{recHS}}$		60			ns
$\overline{\text{HWR}}$ delay time	$t_{\text{dHW}}$	$V_{\text{DD}} = 1.8 \text{ to } 2.7 \text{ V}$	15			ns
		$V_{\text{DD}} = 2.3 \text{ to } 2.7 \text{ V}$	10			ns
$\overline{\text{HWR}}$ width	$t_{\text{wHW}}$		60			ns
$\overline{\text{HWR}}$ hold time	$t_{\text{hHDW}}$		0			ns
$\overline{\text{HWR}}$ setup time	$t_{\text{suHDW}}$	$V_{\text{DD}} = 1.8 \text{ to } 2.7 \text{ V}$	15			ns
		$V_{\text{DD}} = 2.3 \text{ to } 2.7 \text{ V}$	10			ns

Switching characteristics

Parameter	Symbol	Condition	MIN.	TYP.	MAX.	Unit
$\overline{\text{HRE}}$ , $\overline{\text{HWE}}$ output delay time	$t_{\text{dHE}}$	$V_{\text{DD}} = 1.8 \text{ to } 2.7 \text{ V}$			30	ns
		$V_{\text{DD}} = 2.3 \text{ to } 2.7 \text{ V}$			25	ns
$\overline{\text{HRE}}$ , $\overline{\text{HWE}}$ hold time	$t_{\text{hHE}}$	$V_{\text{DD}} = 1.8 \text{ to } 2.7 \text{ V}$			30	ns
		$V_{\text{DD}} = 2.3 \text{ to } 2.7 \text{ V}$			25	ns
$\overline{\text{HRD}}$ valid time	$t_{\text{vHDR}}$	$V_{\text{DD}} = 1.8 \text{ to } 2.7 \text{ V}$			30	ns
		$V_{\text{DD}} = 2.3 \text{ to } 2.7 \text{ V}$			25	ns
$\overline{\text{HRD}}$ hold time	$t_{\text{hHDR}}$		0			ns

$\mu$ PD77111, 77112

**Host read interface timing**

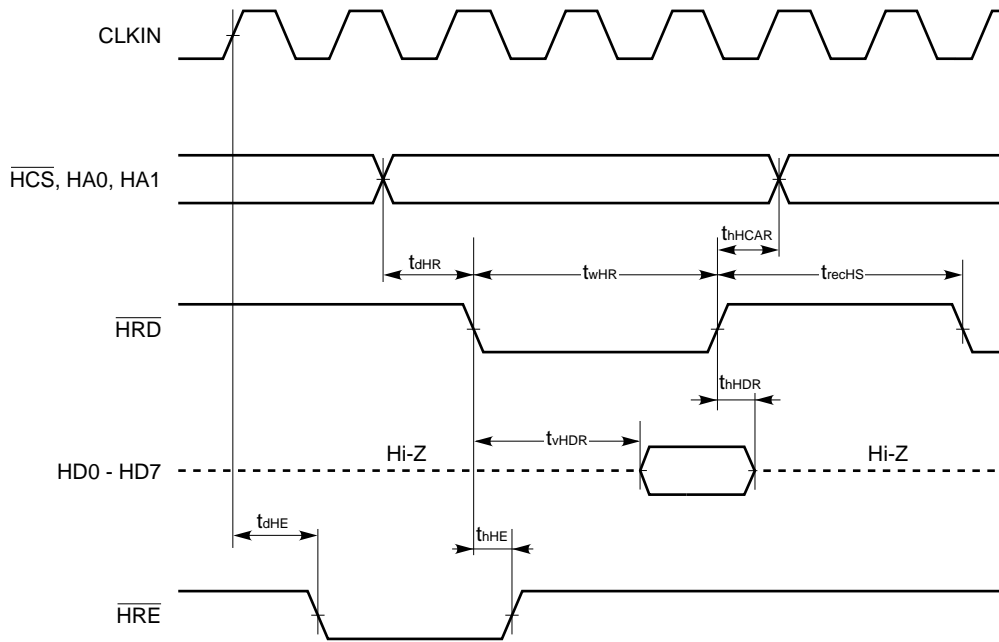

**Host write interface timing**

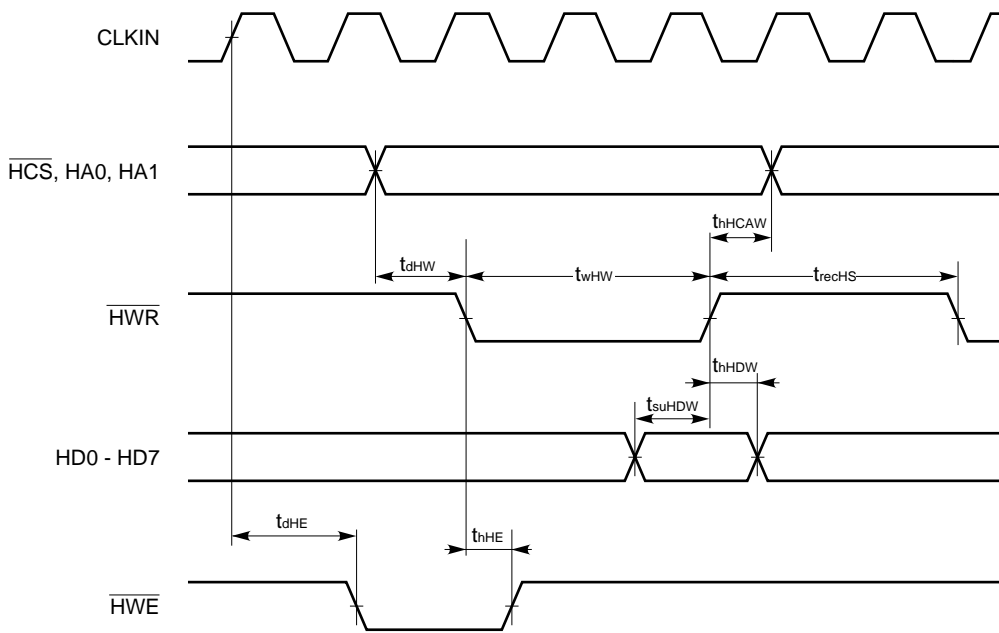

General-purpose I/O Port

Timing requirements

Parameter	Symbol	Condition	MIN.	TYP.	MAX.	Unit
Port input setup time	$t_{suPI}$		0			ns
Port input hold time	$t_{hPI}$	$V_{DD} = 1.8 \text{ to } 2.7 \text{ V}$	15			ns
		$V_{DD} = 2.3 \text{ to } 2.7 \text{ V}$	10			ns

Switching characteristics

Parameter	Symbol	Condition	MIN.	TYP.	MAX.	Unit
Port output delay time	$t_{dPO}$	$V_{DD} = 1.8 \text{ to } 2.7 \text{ V}$			30	ns
		$V_{DD} = 2.3 \text{ to } 2.7 \text{ V}$			25	ns

General-purpose I/O port timing

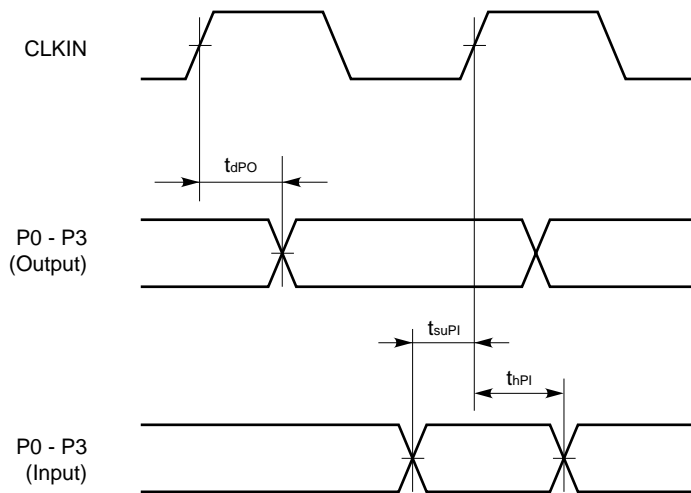

Debugging Interface (JTAG)

Timing requirements

Parameter	Symbol	Condition	MIN.	TYP.	MAX.	Unit
TCK cycle time	$t_{\text{tTCK}}$		120			ns
TCK high-/low-level width	$t_{\text{wTCK}}$		50			ns
TCK rise/fall time	$t_{\text{rTCK}}$				20	ns
TMS, TDI setup time	$t_{\text{suDI}}$	$V_{\text{DD}} = 1.8 \text{ to } 2.7 \text{ V}$	25			ns
		$V_{\text{DD}} = 2.3 \text{ to } 2.7 \text{ V}$	20			ns
TMS, TDI hold time	$t_{\text{hDI}}$	$V_{\text{DD}} = 1.8 \text{ to } 2.7 \text{ V}$	25			ns
		$V_{\text{DD}} = 2.3 \text{ to } 2.7 \text{ V}$	20			ns
Input pin setup time	$t_{\text{suJIN}}$	$V_{\text{DD}} = 1.8 \text{ to } 2.7 \text{ V}$	25			ns
		$V_{\text{DD}} = 2.3 \text{ to } 2.7 \text{ V}$	20			ns
Input pin hold time	$t_{\text{hJIN}}$	$V_{\text{DD}} = 1.8 \text{ to } 2.7 \text{ V}$	25			ns
		$V_{\text{DD}} = 2.3 \text{ to } 2.7 \text{ V}$	20			ns
$\overline{\text{TRST}}$ setup time	$t_{\text{suTRST}}$		100			ns

Switching characteristics

Parameter	Symbol	Condition	MIN.	TYP.	MAX.	Unit
TDO output delay time	$t_{\text{dDO}}$	$V_{\text{DD}} = 1.8 \text{ to } 2.7 \text{ V}$			25	ns
		$V_{\text{DD}} = 2.3 \text{ to } 2.7 \text{ V}$			20	ns
Output pin output delay time	$t_{\text{dJOUT}}$	$V_{\text{DD}} = 1.8 \text{ to } 2.7 \text{ V}$			25	ns
		$V_{\text{DD}} = 2.3 \text{ to } 2.7 \text{ V}$			20	ns

Debugging interface timing

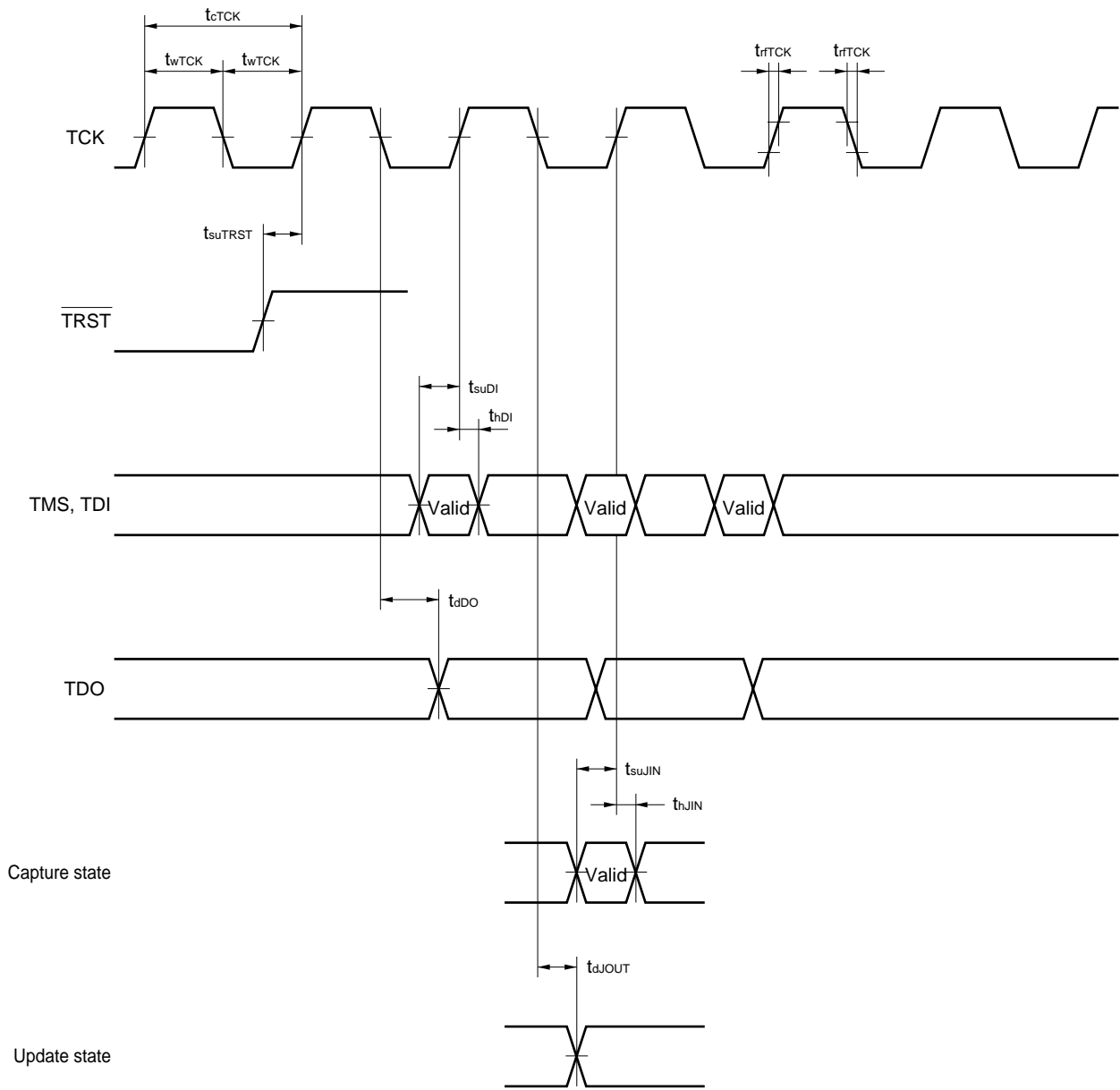

**Remark** For details of JTAG, refer to **IEEE1149.1**.

11. PACKAGE

100-PIN PLASTIC TQFP (FINE PITCH) (14x14)

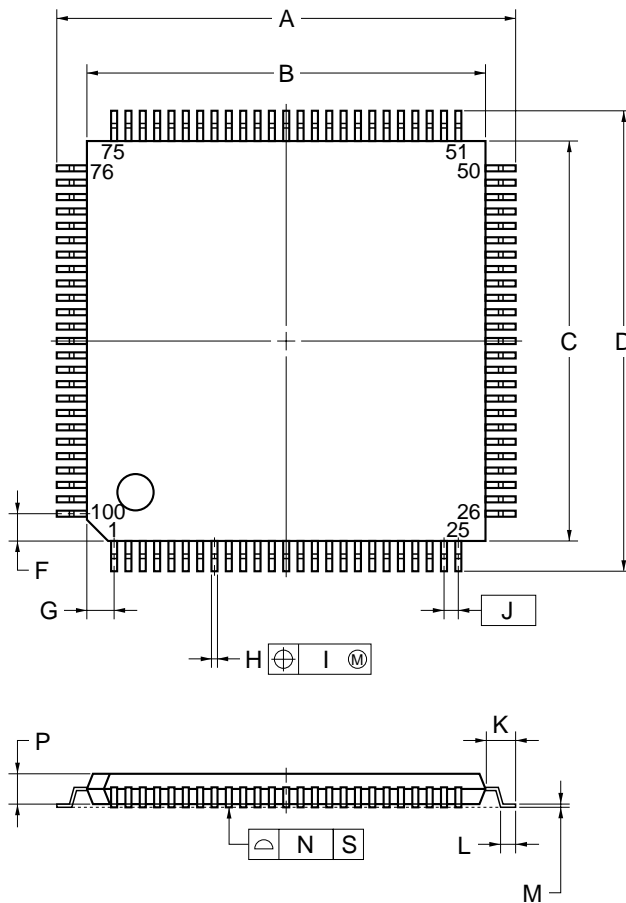

NOTE

Each lead centerline is located within 0.10 mm of its true position (T.P.) at maximum material condition.

ITEM	MILLIMETERS
A	16.0±0.2
B	14.0±0.2
C	14.0±0.2
D	16.0±0.2
F	1.0
G	1.0
H	0.22 <sup>+0.05</sup> <sub>-0.04</sub>
I	0.10
J	0.5 (T.P.)
K	1.0±0.2
L	0.5±0.2
M	0.145 <sup>+0.055</sup> <sub>-0.045</sub>
N	0.10
P	1.0±0.1
Q	0.1±0.05
R	3° <sup>+7°</sup> <sub>-3°</sub>
S	1.27 MAX.

S100GC-50-9EU-2



80-PIN PLASTIC TQFP (FINE PITCH) (12x12)

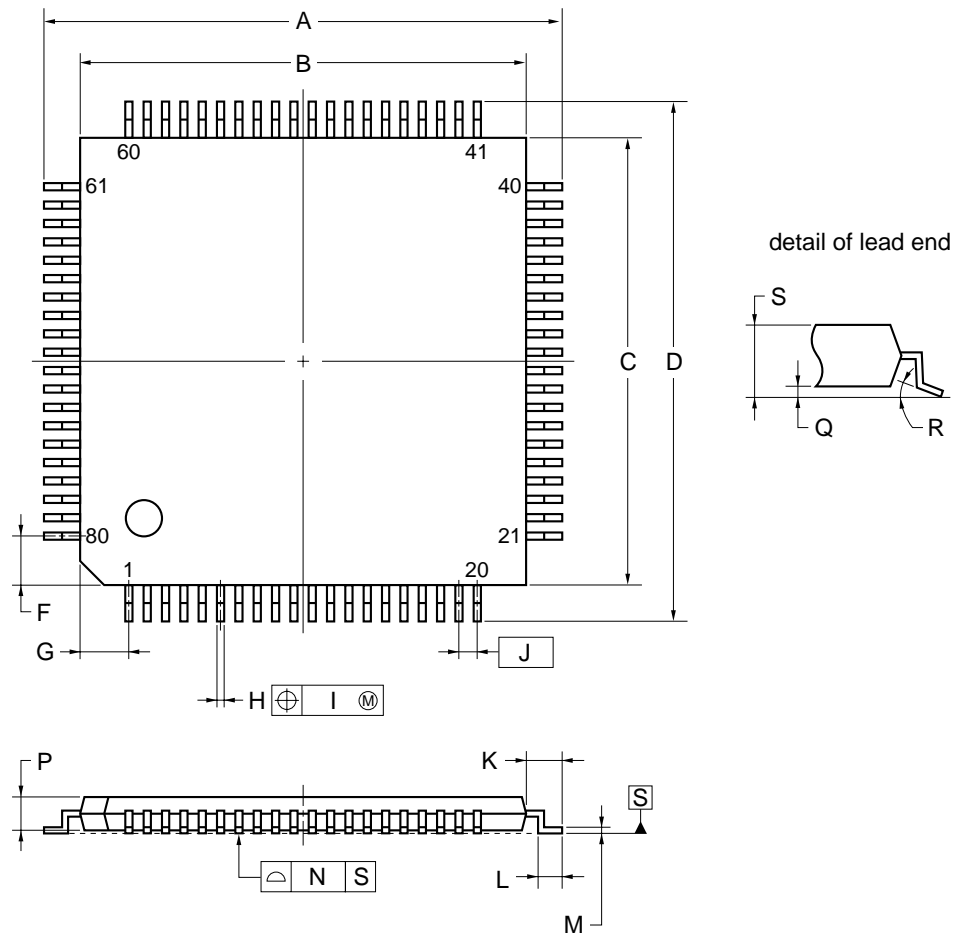

**NOTE**  
 Each lead centerline is located within 0.10 mm of its true position (T.P.) at maximum material condition.

ITEM	MILLIMETERS
A	14.0±0.2
B	12.0±0.2
C	12.0±0.2
D	14.0±0.2
F	1.25
G	1.25
H	0.22±0.05
I	0.10
J	0.5 (T.P.)
K	1.0±0.2
L	0.5±0.2
M	0.145±0.05
N	0.10
P	1.0±0.05
Q	0.1±0.05
R	3°+7° -3°
S	1.2 MAX.

S80GK-50-9EU-1

80-PIN PLASTIC FBGA (9x9)

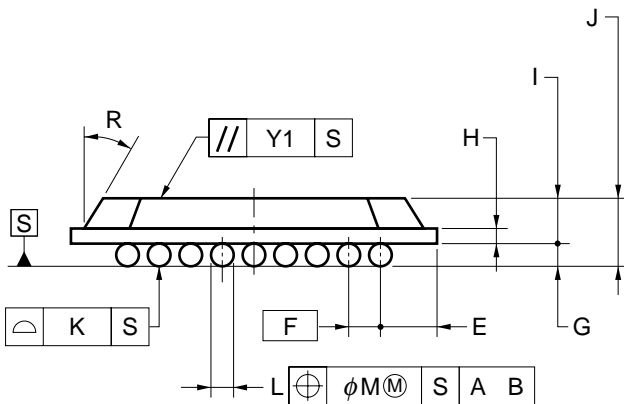
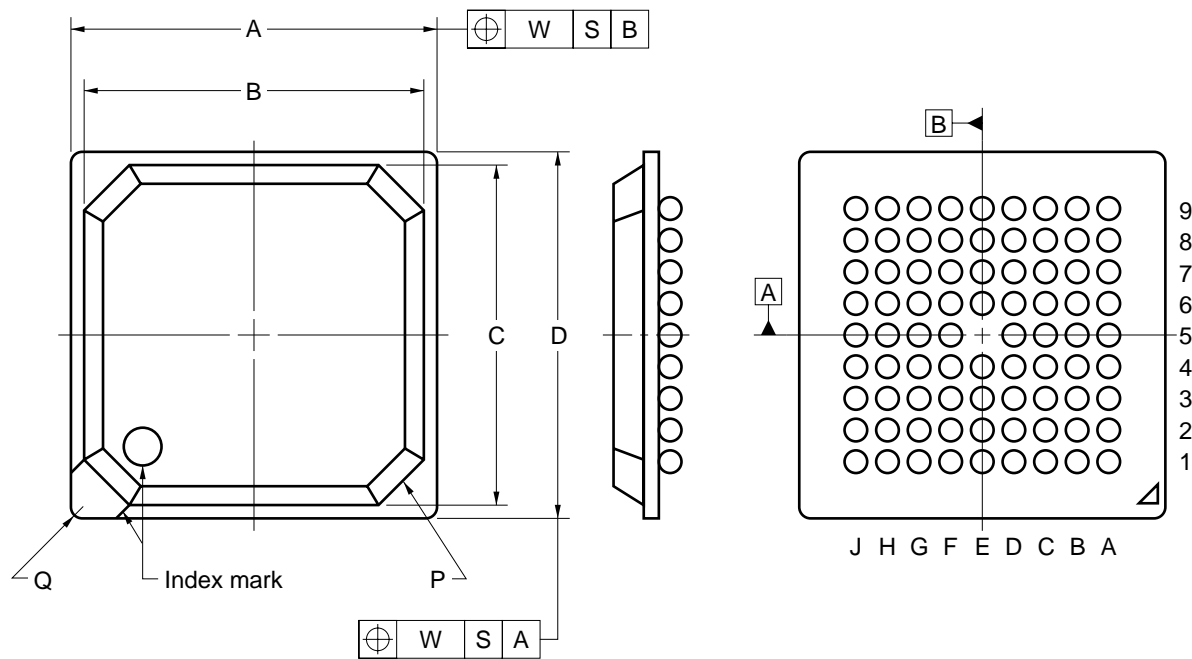

ITEM	MILLIMETERS
A	9.00±0.10
B	8.40
C	8.40
D	9.00±0.10
E	1.30
F	0.8 (T.P.)
G	0.35±0.1
H	0.36
I	0.96
J	1.31±0.15
K	0.10
L	$\phi 0.50^{+0.05}_{-0.10}$
M	0.08
P	C1.0
Q	R0.3
R	25°
W	0.20
Y1	0.20

S80F1-80-CN1-1

**12. RECOMMENDED SOLDERING CONDITIONS**

It is recommended to solder this product under the following conditions.

For details of the recommended soldering conditions, refer to information document “**SEMICONDUCTOR DEVICE MOUNTING TECHNOLOGY MANUAL**” (C10535E).

For soldering methods and conditions other than those recommended, consult NEC.

**Surface mount type**

**μPD77110GC-9EU: 100-pin plastic TQFP (fine pitch) (14 × 14 mm)**

**μPD77111GK-xxx-9EU: 80-pin plastic TQFP (fine pitch) (12 × 12 mm)**

Process	Conditions	Symbol
Infrared ray reflow	Package peak temperature: 235°C, Time: 30 seconds MAX (210°C MIN), Number of times: 2 MAX, Number of days: 3 <sup>Note</sup> (after that, prebaking is necessary for 10 hours)	IR35-103-2
VPS	Package peak temperature: 215°C, Time: 30 seconds MAX (210°C MIN), Number of times: 2 MAX, Number of days: 3 <sup>Note</sup> (after that, prebaking is necessary for 10 hours)	VP15-103-2
Partial heating method	Pin temperature: 300°C MAX, Time: 3 seconds MAX (per side of device)	–

**μPD77112GC-xxx-9EU: 100-pin plastic TQFP (fine pitch) (14 × 14 mm)**

Process	Conditions	Symbol
Infrared ray reflow	Package peak temperature: 235°C, Time: 30 seconds MAX (210°C MIN), Number of times: 3 MAX, Number of days: 7 <sup>Note</sup> (after that, prebaking is necessary for 10 hours)	IR35-107-3
VPS	Package peak temperature: 215°C, Time: 30 seconds MAX (210°C MIN), Number of times: 3 MAX, Number of days: 7 <sup>Note</sup> (after that, prebaking is necessary for 10 hours)	VP15-107-3
Partial heating method	Pin temperature: 300°C MAX, Time: 3 seconds MAX (per side of device)	–

**Note** Number of days in storage after the dry pack has been opened. The storage conditions are at 25°C, 65% RH MAX.

**Caution** Do not use two or more soldering methods in combination (except partial heating method).

**μPD77111F1-xxx-CN1: 80-pin plastic fine-pitch BGA (9 × 9 mm)**

Process	Conditions	Symbol
Infrared ray reflow	Package peak temperature: 230°C, Time: 30 seconds MAX (210°C MIN), Number of times: 2 MAX, Number of days: 3 <sup>Note</sup> (after that, prebaking is necessary for 10 hours)	IR30-103-2
VPS	Package peak temperature: 215°C, Time: 30 seconds MAX (210°C MIN), Number of times: 2 MAX, Number of days: 3 <sup>Note</sup> (after that, prebaking is necessary for 10 hours)	VP15-103-2

**Note** Number of days in storage after the dry pack has been opened. The storage conditions are at 25°C, 65% RH MAX.

**Caution** Do not use two or more soldering methods in combination (except partial heating method).

[MEMO]

**NOTES FOR CMOS DEVICES****① PRECAUTION AGAINST ESD FOR SEMICONDUCTORS**

Note:

Strong electric field, when exposed to a MOS device, can cause destruction of the gate oxide and ultimately degrade the device operation. Steps must be taken to stop generation of static electricity as much as possible, and quickly dissipate it once, when it has occurred. Environmental control must be adequate. When it is dry, humidifier should be used. It is recommended to avoid using insulators that easily build static electricity. Semiconductor devices must be stored and transported in an anti-static container, static shielding bag or conductive material. All test and measurement tools including work bench and floor should be grounded. The operator should be grounded using wrist strap. Semiconductor devices must not be touched with bare hands. Similar precautions need to be taken for PW boards with semiconductor devices on it.

**② HANDLING OF UNUSED INPUT PINS FOR CMOS**

Note:

No connection for CMOS device inputs can be cause of malfunction. If no connection is provided to the input pins, it is possible that an internal input level may be generated due to noise, etc., hence causing malfunction. CMOS devices behave differently than Bipolar or NMOS devices. Input levels of CMOS devices must be fixed high or low by using a pull-up or pull-down circuitry. Each unused pin should be connected to  $V_{DD}$  or GND with a resistor, if it is considered to have a possibility of being an output pin. All handling related to the unused pins must be judged device by device and related specifications governing the devices.

**③ STATUS BEFORE INITIALIZATION OF MOS DEVICES**

Note:

Power-on does not necessarily define initial status of MOS device. Production process of MOS does not define the initial operation status of the device. Immediately after the power source is turned ON, the devices with reset function have not yet been initialized. Hence, power-on does not guarantee out-pin levels, I/O settings or contents of registers. Device is not initialized until the reset signal is received. Reset operation must be executed immediately after power-on for devices having reset function.

## Regional Information

Some information contained in this document may vary from country to country. Before using any NEC product in your application, please contact the NEC office in your country to obtain a list of authorized representatives and distributors. They will verify:

- Device availability
- Ordering information
- Product release schedule
- Availability of related technical literature
- Development environment specifications (for example, specifications for third-party tools and components, host computers, power plugs, AC supply voltages, and so forth)
- Network requirements

In addition, trademarks, registered trademarks, export restrictions, and other legal issues may also vary from country to country.

**NEC Electronics Inc. (U.S.)**

Santa Clara, California  
 Tel: 408-588-6000  
 800-366-9782  
 Fax: 408-588-6130  
 800-729-9288

**NEC Electronics (Germany) GmbH**

Duesseldorf, Germany  
 Tel: 0211-65 03 02  
 Fax: 0211-65 03 490

**NEC Electronics (UK) Ltd.**

Milton Keynes, UK  
 Tel: 01908-691-133  
 Fax: 01908-670-290

**NEC Electronics Italiana s.r.l.**

Milano, Italy  
 Tel: 02-66 75 41  
 Fax: 02-66 75 42 99

**NEC Electronics (Germany) GmbH**

Benelux Office  
 Eindhoven, The Netherlands  
 Tel: 040-2445845  
 Fax: 040-2444580

**NEC Electronics (France) S.A.**

Velizy-Villacoublay, France  
 Tel: 01-30-67 58 00  
 Fax: 01-30-67 58 99

**NEC Electronics (France) S.A.**

Spain Office  
 Madrid, Spain  
 Tel: 91-504-2787  
 Fax: 91-504-2860

**NEC Electronics (Germany) GmbH**

Scandinavia Office  
 Taebly, Sweden  
 Tel: 08-63 80 820  
 Fax: 08-63 80 388

**NEC Electronics Hong Kong Ltd.**

Hong Kong  
 Tel: 2886-9318  
 Fax: 2886-9022/9044

**NEC Electronics Hong Kong Ltd.**

Seoul Branch  
 Seoul, Korea  
 Tel: 02-528-0303  
 Fax: 02-528-4411

**NEC Electronics Singapore Pte. Ltd.**

United Square, Singapore 1130  
 Tel: 65-253-8311  
 Fax: 65-250-3583

**NEC Electronics Taiwan Ltd.**

Taipei, Taiwan  
 Tel: 02-2719-2377  
 Fax: 02-2719-5951

**NEC do Brasil S.A.**

Electron Devices Division  
 Rodovia Presidente Dutra, Km 214  
 07210-902-Guarulhos-SP Brasil  
 Tel: 55-11-6465-6810  
 Fax: 55-11-6465-6829

J99.1

The export of these products from Japan is regulated by the Japanese government. The export of some or all of these products may be prohibited without governmental license. To export or re-export some or all of these products from a country other than Japan may also be prohibited without a license from that country. Please call an NEC sales representative.

License not needed :  $\mu$ PD77110GC-9EU

The customer must judge the need for license:  $\mu$ PD77111GK-xxx-9EU,  $\mu$ PD77111F1-xxx-CN1,  
 $\mu$ PD77112GC-xxx-9EU

• **The information in this document is subject to change without notice. Before using this document, please confirm that this is the latest version.**

- No part of this document may be copied or reproduced in any form or by any means without the prior written consent of NEC Corporation. NEC Corporation assumes no responsibility for any errors which may appear in this document.
- NEC Corporation does not assume any liability for infringement of patents, copyrights or other intellectual property rights of third parties by or arising from use of a device described herein or any other liability arising from use of such device. No license, either express, implied or otherwise, is granted under any patents, copyrights or other intellectual property rights of NEC Corporation or others.
- Descriptions of circuits, software, and other related information in this document are provided for illustrative purposes in semiconductor product operation and application examples. The incorporation of these circuits, software, and information in the design of the customer's equipment shall be done under the full responsibility of the customer. NEC Corporation assumes no responsibility for any losses incurred by the customer or third parties arising from the use of these circuits, software, and information.
- While NEC Corporation has been making continuous effort to enhance the reliability of its semiconductor devices, the possibility of defects cannot be eliminated entirely. To minimize risks of damage or injury to persons or property arising from a defect in an NEC semiconductor device, customers must incorporate sufficient safety measures in its design, such as redundancy, fire-containment, and anti-failure features.
- NEC devices are classified into the following three quality grades:  
"Standard", "Special", and "Specific". The Specific quality grade applies only to devices developed based on a customer designated "quality assurance program" for a specific application. The recommended applications of a device depend on its quality grade, as indicated below. Customers must check the quality grade of each device before using it in a particular application.

Standard: Computers, office equipment, communications equipment, test and measurement equipment, audio and visual equipment, home electronic appliances, machine tools, personal electronic equipment and industrial robots

Special: Transportation equipment (automobiles, trains, ships, etc.), traffic control systems, anti-disaster systems, anti-crime systems, safety equipment and medical equipment (not specifically designed for life support)

Specific: Aircraft, aerospace equipment, submersible repeaters, nuclear reactor control systems, life support systems or medical equipment for life support, etc.

The quality grade of NEC devices is "Standard" unless otherwise specified in NEC's Data Sheets or Data Books. If customers intend to use NEC devices for applications other than those specified for Standard quality grade, they should contact an NEC sales representative in advance.