

## 16-BIT SINGLE-CHIP MICROCONTROLLER

**DESCRIPTION**

The  $\mu$ PD78F4938A is a product in the  $\mu$ PD784938A Subseries in the 78K/IV Series.

The  $\mu$ PD78F4938A has flash memory in place of the internal ROM of the  $\mu$ PD784938A. The flash memory incorporated enables program writing or erasing with the microcontroller mounted on the target board.

**Detailed function descriptions are provided in the following user's manuals. Be sure to read them before designing.**

$\mu$ PD784938A Subseries User's Manual Hardware: U13570E

78K/IV Series User's Manual Instructions: U10905E

**FEATURES**

- Pin-compatible with mask ROM version (except V<sub>PP</sub> pin)
- Flash memory: 256 KB
- Internal RAM: 10496 bytes
- Serial interface: 4 channels
  - UART/IOE (3-wire serial I/O): 2 channels (on-chip baud rate generator)
  - CSI (3-wire serial I/O): 2 channels
- On-chip IEBus™ controller
- Supply voltage: V<sub>DD</sub> = 4.0 to 5.5 V (@12.58 MHz operation)  
V<sub>DD</sub> = 3.0 to 5.5 V (@6.29 MHz operation)

**APPLICATION**

Car audio, etc.

**ORDERING INFORMATION**

Part Number	Package	Internal ROM	Internal RAM
$\mu$ PD78F4938AGF-3BA	100-pin plastic QFP (14 × 20)	256 KB	10496 bytes

The information in this document is subject to change without notice. Before using this document, please confirm that this is the latest version.

Not all devices/types available in every country. Please check with local NEC representative for availability and additional information.

78K/IV SERIES LINEUP

: Products in mass-production

: Products under development

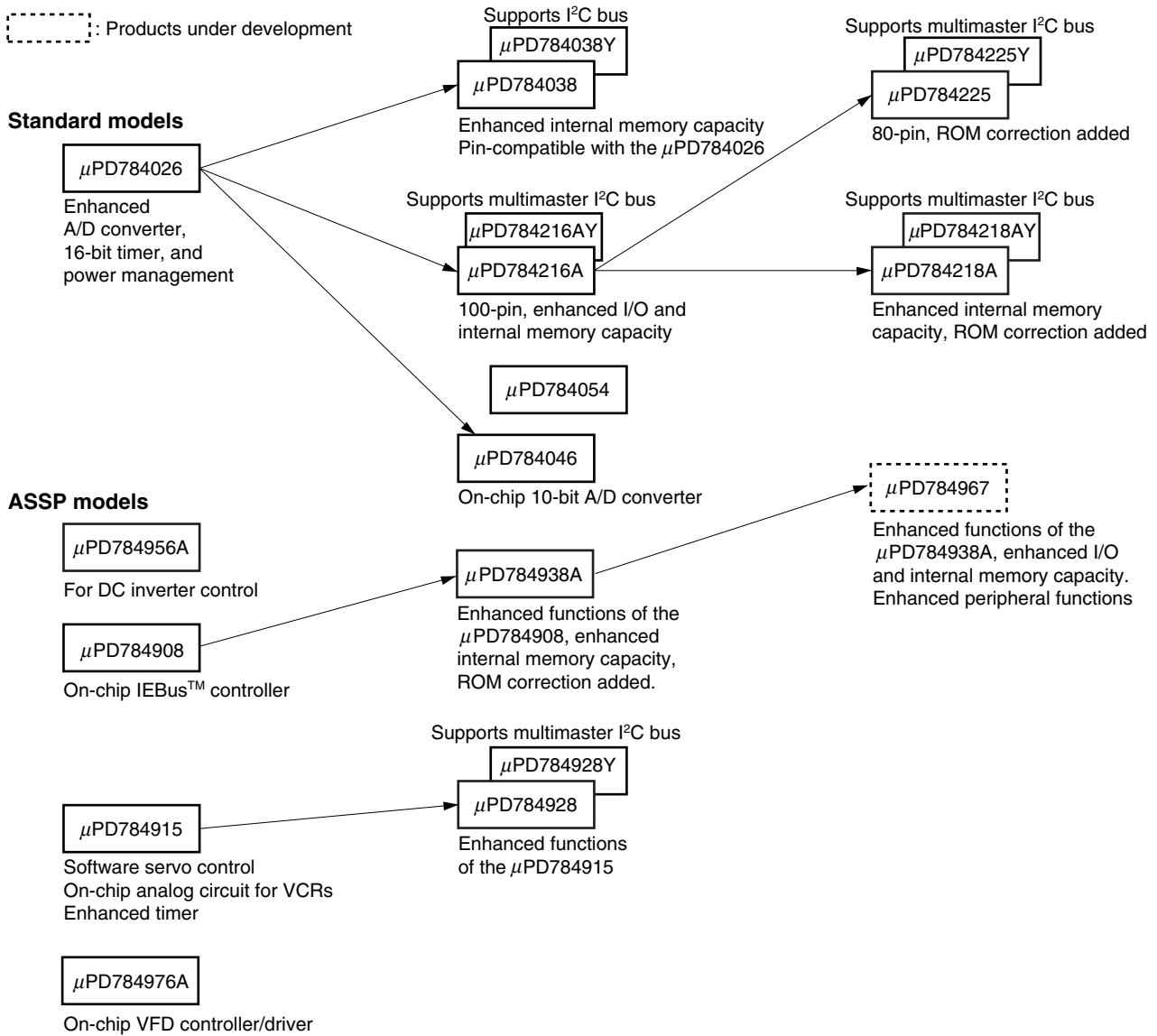

**Remark** Although VFD (Vacuum Florescent Display is generally used, in some documents, the display is described as FIP™ (Florescent Indicator Panel). VFD and FIP are functionally equivalent.

OVERVIEW OF FUNCTIONS

(1/2)

Part Number		μPD78F4938A	
Item			
Number of basic instructions (mnemonics)	113		
General-purpose registers	8 bits × 32 registers × 8 banks, or 16 bits × 8 registers × 8 banks (memory map)		
Minimum instruction execution time	320 ns/636 ns/1.27 μs/2.54 μs (@6.29 MHz operation) 160 ns/320 ns/636 ns/1.27 μs (@12.58 MHz operation)		
Internal memory	ROM	256 KB	
	RAM	10496 bytes	
Memory space	1 MB with program and data spaces combined		
I/O port	Total	80 pins	
	Input	8 pins	
	I/O	72 pins	
Pins with ancillary function <sup>Note</sup>	LED direct drive output	24 pins	
	Transistor direct drive	8 pins	
	N-ch open drain drive	4 pins	
Real-time output port	4 bits × 2, or 8 bits × 1		
IEBus controller	Internal (simple version)		
Timer/counter	Timer/event counter 0: (16 bits)	Timer counter × 1 Capture register × 1 Compare register × 2	Pulse output possible • Toggle output • PWM/PPG output • One-shot pulse output
	Timer/event counter 1: (16 bits)	Timer counter × 1 Capture register × 1 Capture/compare register × 1 Compare register × 1	Real-time output port
	Timer/event counter 2: (16 bits)	Timer counter × 1 Capture register × 1 Capture/compare register × 1 Compare register × 1	Pulse output possible • Toggle output • PWM/PPG output
	Timer 3 (16 bits):	Timer counter × 1 Compare register × 1	
Watch timer	Generates interrupt request at 0.5-second intervals (On-chip watch clock oscillator) Main clock (12.58 MHz) or watch clock (32.7 kHz) selectable as input clock		
Clock output	Selectable from f <sub>CLK</sub> , f <sub>CLK</sub> /2, f <sub>CLK</sub> /4, f <sub>CLK</sub> /8, or f <sub>CLK</sub> /16 (also usable as 1-bit output port)		
PWM output	12-bit resolution × 2 channels		
Serial interface	UART/IOE (3-wire serial I/O): 2 channels (on-chip baud rate generator) CSI (3-wire serial I/O): 2 channels		
A/D converter	8-bit resolution × 8 channels		
Watchdog timer	1 channel		
ROM correction function	Internal (4 points of correction addresses can be set.)		
External expansion function	Provided (up to 1 MB)		

**Note** Pins with ancillary functions are included in the I/O pins.

(2/2)

Item	Part Number	μPD78F4938A
Standby		HALT/STOP/IDLE mode
Interrupt	Hardware source	27 (internal: 20, external: 7 (sampling clock variable input: 1))
	Software source	BRK instruction, BRKCS instruction, operand error
	Non-maskable	Internal: 1, external: 1
	Maskable	Internal: 19, external: 6
		Four programmable priority levels Three types of processing formats: Vectored interrupt/macro service/context switching
Supply voltage		<ul style="list-style-type: none"> <li>• V<sub>DD</sub> = 4.0 to 5.5 V (@12.58 MHz operation)</li> <li>• V<sub>DD</sub> = 3.0 to 5.5 V (@6.29 MHz operation)</li> </ul>
Package		100-pin plastic QFP (14 × 20)

**CONTENTS**

1. DIFFERENCES AMONG PRODUCTS IN μPD784938A SUBSERIES ..... 6

2. PIN CONFIGURATION (TOP VIEW)..... 7

3. BLOCK DIAGRAM ..... 9

4. PIN FUNCTIONS ..... 10

    4.1 Port Pins ..... 10

    4.2 Non-Port Pins ..... 12

    4.3 Pin I/O Circuits and Recommended Connection of Unused Pins ..... 14

5. INTERNAL MEMORY SIZE SWITCHING REGISTER (IMS) ..... 18

6. PROGRAMMING FLASH MEMORY ..... 19

    6.1 Selecting Communication Mode ..... 19

    6.2 Flash Memory Programming Functions ..... 20

    6.3 Connecting Flashpro III ..... 21

7. ELECTRICAL SPECIFICATIONS..... 22

8. PACKAGE DRAWING ..... 42

9. RECOMMENDED SOLDERING CONDITIONS..... 43

APPENDIX A. DEVELOPMENT TOOLS..... 44

APPENDIX B. RELATED DOCUMENTS ..... 47

1. DIFFERENCES AMONG PRODUCTS IN μPD784938A SUBSERIES

The only difference between the μPD784935A, 784936A, 784937A, and 784938A is the internal memory capacity.

The μPD78F4938A has a 256 KB flash memory in the place of the mask ROM of the above products. Table 1-1 shows the differences between these products.

Table 1-1. Differences Among Products in μPD784938A Subseries

Item \ Part Number	μPD784935A	μPD784936A	μPD784937A	μPD784938A	μPD78F4938A
Internal ROM	96 KB	128 KB	192 KB	256 KB	
	Mask ROM				Flash memory
Internal RAM	5120 bytes	6656 bytes	8192 bytes	10496 bytes	
Regulator	Provided				None
Electrical specifications	Refer to the data sheet of each product.				
Internal memory size switching register <sup>Note</sup>	None				Provided
IC pin	Provided				None
V <sub>PP</sub> pin	None				Provided

**Note** The internal flash memory capacity and internal RAM capacity can be changed by using the internal memory size switching register (IMS).

**Caution** There are differences in noise immunity and noise radiation between the flash memory and mask ROM versions. When pre-producing an application set with the flash memory version and then mass-producing it with the mask ROM version, be sure to conduct sufficient evaluations for the commercial samples (not engineering samples) of the mask ROM version.

2. PIN CONFIGURATION (TOP VIEW)

- 100-pin plastic QFP (14 × 20)  
μPD78F4938AGF-3BA

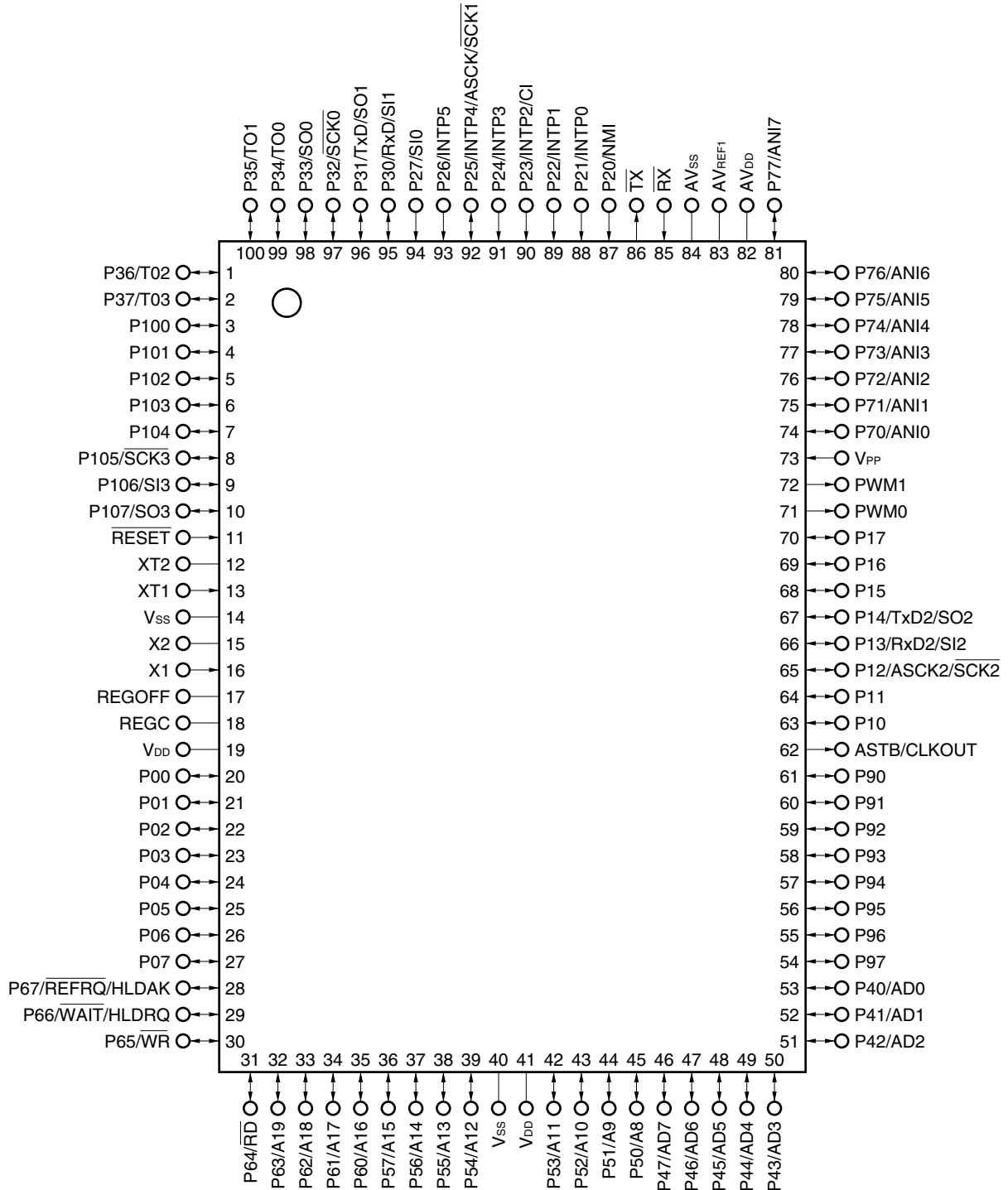

- Cautions**
1. In normal operation mode, connect V<sub>PP</sub> pin directly to the V<sub>SS</sub> pin, or pull it down.  
In a system where the internal flash memory is rewritten while mounted on board, pull the V<sub>PP</sub> pin down.  
When pulling down, connection via a 470Ω or higher and 10 kΩ or lower resistor is recommended.
  2. Connect the AV<sub>DD</sub> pin directly to V<sub>DD</sub>.
  3. Connect the AV<sub>SS</sub> pin directly to V<sub>SS</sub>.

A8 to A19:	Address bus	PWM0, PWM1:	Pulse width modulation output
AD0 to AD7:	Address/data bus	$\overline{RD}$ :	Read strobe
ANI0 to ANI7:	Analog input	$\overline{REFRQ}$ :	Refresh request
ASCK, ASCK2:	Asynchronous serial clock	REGC:	Regulator capacitance
ASTB:	Address strobe	REGOFF:	Regulator off
AV <sub>DD</sub> :	Analog power supply	$\overline{RESET}$ :	Reset
AV <sub>REF1</sub> :	Reference voltage	$\overline{RX}$ :	IEBus receive data
AV <sub>SS</sub> :	Analog ground	RxD, RxD2:	Receive data
Cl:	Clock input	$\overline{SCK0}$ to $\overline{SCK3}$ :	Serial clock
CLKOUT:	Clock output	SI0 to SI3:	Serial input
HLD <sub>AK</sub> :	Hold acknowledge	SO0 to SO3:	Serial output
HLD <sub>RQ</sub> :	Hold request	TO0 to TO3:	Timer output
INTP0 to INTP5:	Interrupt from peripherals	$\overline{TX}$ :	IEBus transmit data
NMI:	Non-maskable interrupt	TxD, TxD2:	Transmit data
P00 to P07:	Port 0	V <sub>DD</sub> :	Power supply
P10 to P17:	Port 1	V <sub>PP</sub> :	Programming power supply
P20 to P27:	Port 2	V <sub>SS</sub> :	Ground
P30 to P37:	Port 3	$\overline{WAIT}$ :	Wait
P40 to P47:	Port 4	$\overline{WR}$ :	Write strobe
P50 to P57:	Port 5	X1, X2:	Crystal (main system clock)
P60 to P67:	Port 6	XT1, XT2:	Crystal (watch)
P70 to P77:	Port 7		
P90 to P97:	Port 9		
P100 to P107:	Port 10		



3. BLOCK DIAGRAM

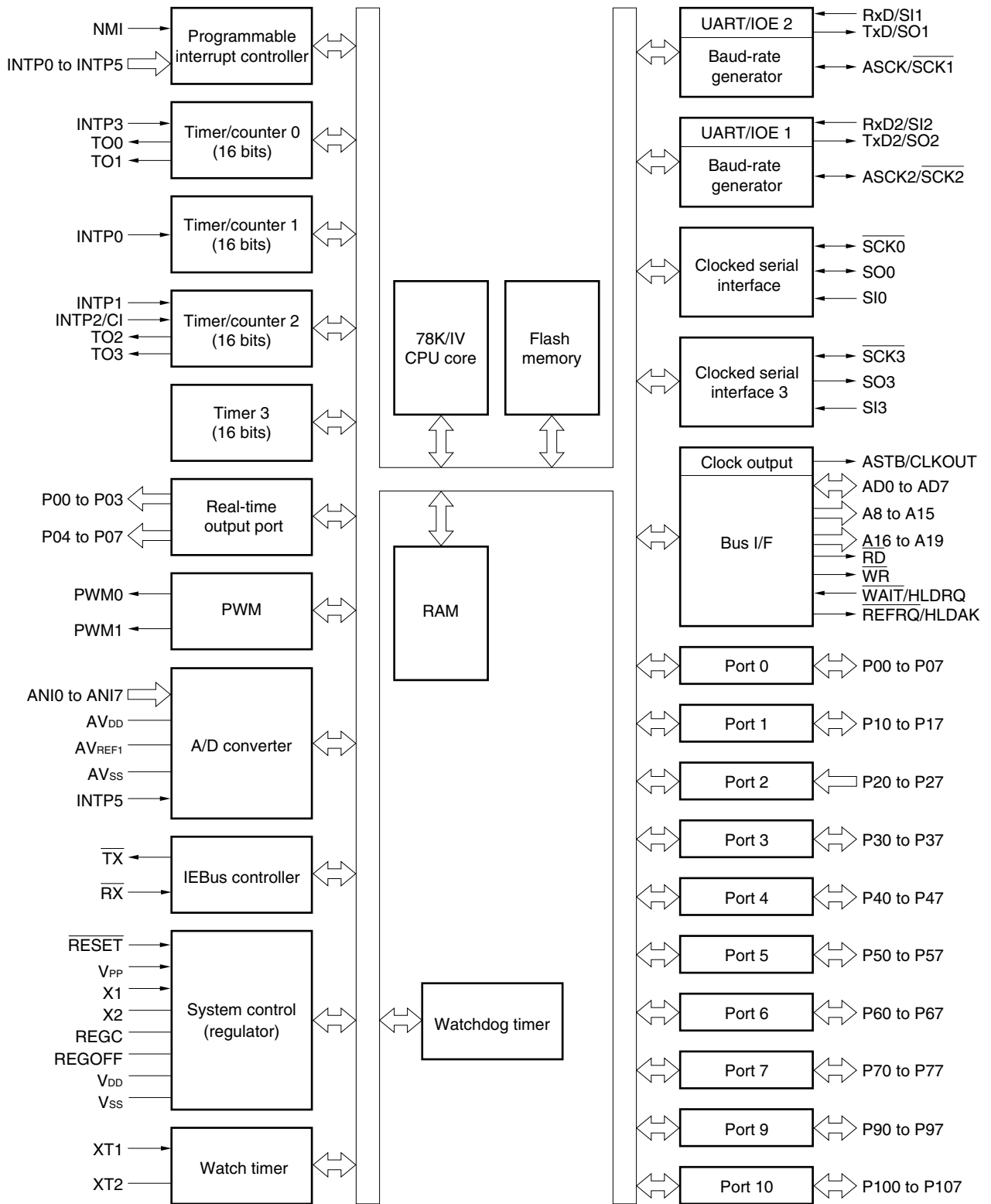

4. PIN FUNCTIONS

4.1 Port Pins (1/2)

Pin Name	I/O	Alternate Function	Function
P00 to P07	I/O	—	<p>Port 0 (P0):</p> <ul style="list-style-type: none"> <li>• 8-bit I/O port.</li> <li>• Can be used as real-time output port (4 bits × 2).</li> <li>• Input/output can be specified in 1-bit units.</li> <li>• An on-chip pull-up resistor can be specified by means of software for pins in input mode.</li> <li>• Can drive transistor.</li> </ul>
P10	I/O	—	<p>Port 1 (P1):</p> <ul style="list-style-type: none"> <li>• 8-bit I/O port.</li> <li>• Input/output can be specified in 1-bit units.</li> <li>• An on-chip pull-up resistor can be specified by means of software for pins in input mode.</li> <li>• Can drive LED.</li> </ul>
P11		—	
P12		ASCK2/SCK2	
P13		RxD2/SI2	
P14		TxD2/SO2	
P15 to 17		—	
P20	Input	NMI	<p>Port 2 (P2):</p> <ul style="list-style-type: none"> <li>• 8-bit input port.</li> <li>• P20 cannot be used as general-purpose port pin (non-maskable interrupt). However, input level can be checked by interrupt routine.</li> <li>• An on-chip pull-up resistor can be specified for P22 to P27 by means of software in 6-bit units.</li> <li>• P25/INTP4/ASCK/SCK1 pin operates as SCK1 I/O pin if so specified by CSIM1.</li> </ul>
P21		INTP0	
P22		INTP1	
P23		INTP2/CI	
P24		INTP3	
P25		INTP4/ASCK/SCK1	
P26		INTP5	
P27		SI0	
P30	I/O	RxD/SI1	<p>Port 3 (P3):</p> <ul style="list-style-type: none"> <li>• 8-bit I/O port.</li> <li>• Input/output can be specified in 1-bit units.</li> <li>• An on-chip pull-up resistor can be specified by means of software for pins in input mode.</li> <li>• P32 and P33 can be specified for N-ch open-drain connection.</li> </ul>
P31		TxD/SO1	
P32		SCK0	
P33		SO0	
P34 to P37		TO0 to TO3	
P40 to P47	I/O	AD0 to AD7	<p>Port 4 (P4):</p> <ul style="list-style-type: none"> <li>• 8-bit I/O port.</li> <li>• Input/output can be specified in 1-bit units.</li> <li>• An on-chip pull-up resistor can be specified by means of software for pins in input mode.</li> <li>• Can drive LED.</li> </ul>
P50 to P57	I/O	A8 to A15	<p>Port 5 (P5):</p> <ul style="list-style-type: none"> <li>• 8-bit I/O port.</li> <li>• Input/output can be specified in 1-bit units.</li> <li>• An on-chip pull-up resistor can be specified by means of software for pins in input mode.</li> <li>• Can drive LED.</li> </ul>
P60 to P63	I/O	A16 to A19	<p>Port 6 (P6):</p> <ul style="list-style-type: none"> <li>• 8-bit I/O port.</li> <li>• Input/output can be specified in 1-bit units.</li> <li>• An on-chip pull-up resistor can be specified by means of software for pins in input mode.</li> </ul>
P64		RD	
P65		WR	
P66		WAIT/HLDRQ	
P67		REFRQ/HLDAK	

4.1 Port Pins (2/2)

Pin Name	I/O	Alternate Function	Function
P70 to P77	I/O	ANI0 to ANI7	Port 7 (P7): <ul style="list-style-type: none"> <li>• 8-bit I/O port.</li> <li>• Input/output can be specified in 1-bit units.</li> </ul>
P90 to P97	I/O	—	Port 9 (P9): <ul style="list-style-type: none"> <li>• 8-bit I/O port.</li> <li>• Input/output can be specified in 1-bit units.</li> <li>• An on-chip pull-up resistor can be specified by means of software for pins in input mode.</li> </ul>
P100 to P104	I/O	—	Port 10 (P10): <ul style="list-style-type: none"> <li>• 8-bit I/O port.</li> <li>• Input/output can be specified in 1-bit units.</li> <li>• An on-chip pull-up resistor can be specified by means of software for pins in input mode.</li> <li>• P105 and P107 can be specified for N-ch open-drain connection.</li> </ul>
P105		$\overline{\text{SCK3}}$	
P106		SI3	
P107		SO3	

4.2 Non-Port Pins (1/2)

Pin Name	I/O	Alternate Function	Function
TO0 to TO3	Output	P34 to P37	Timer output
CI	Input	P23/INTP2	Count clock input to timer/counter 2
RxD	Input	P30/SI1	Serial data input (UART0)
RxD2		P13/SI2	Serial data input (UART2)
TxD	Output	P31/SO1	Serial data output (UART0)
TxD2		P14/SO2	Serial data output (UART2)
ASCK	Input	P25/INTP4/ $\overline{\text{SCK1}}$	Baud rate clock input (UART0)
ASCK2		P12/ $\overline{\text{SCK2}}$	Baud rate clock input (UART2)
SI0	Input	P27	Serial data input (3-wire serial I/O0)
SI1		P30/RxD	Serial data input (3-wire serial I/O1)
SI2		P13/RxD2	Serial data input (3-wire serial I/O2)
SI3		P106	Serial data input (3-wire serial I/O3)
SO0	Output	P33	Serial data output (3-wire serial I/O0)
SO1		P31/TxD	Serial data output (3-wire serial I/O1)
SO2		P14/TxD2	Serial data output (3-wire serial I/O2)
SO3		P107	Serial data output (3-wire serial I/O3)
$\overline{\text{SCK0}}$	I/O	P32	Serial clock input/output (3-wire serial I/O0)
$\overline{\text{SCK1}}$		P25/INTP4/ASCK	Serial clock input/output (3-wire serial I/O1)
$\overline{\text{SCK2}}$		P12/ASCK2	Serial clock input/output (3-wire serial I/O2)
$\overline{\text{SCK3}}$		P105	Serial clock input/output (3-wire serial I/O3)
NMI	Input	P20	External interrupt requests
INTP0		P21	<ul style="list-style-type: none"> <li>Count clock input to timer/counter 1</li> <li>Capture trigger signal of CR11 or CR12</li> </ul>
INTP1		P22	<ul style="list-style-type: none"> <li>Count clock input to timer/counter 2</li> <li>Capture trigger signal of CR22</li> </ul>
INTP2		P23/CI	<ul style="list-style-type: none"> <li>Count clock input to timer/counter 2</li> <li>Capture trigger signal of CR21</li> </ul>
INTP3		P24	<ul style="list-style-type: none"> <li>Count clock input to timer/counter 0</li> <li>Capture trigger signal of CR02</li> </ul>
INTP4		P25/ASCK/ $\overline{\text{SCK1}}$	—
INTP5		P26	Conversion start trigger input of A/D converter
AD0 to AD7	I/O	P40 to P47	Time-division address/data bus (external memory connection)
A8 to A15	Output	P50 to P57	Higher address bus (external memory connection)
A16 to A19	Output	P60 to P63	Higher address for address extension (external memory connection)
$\overline{\text{RD}}$	Output	P64	Read strobe to external memory
$\overline{\text{WR}}$	Output	P65	Write strobe to external memory
$\overline{\text{WAIT}}$	Input	P66/HLDRQ	Wait insertion
$\overline{\text{REFRQ}}$	Output	P67/HLDAK	Refresh pulse output to external pseudo-static memory
HLDRQ	Input	P66/ $\overline{\text{WAIT}}$	Bus hold request input
HLDAK	Output	P67/ $\overline{\text{REFRQ}}$	Bus hold acknowledge output
ASTB	Output	CLKOUT	Latch timing output of time-division address (A0 to A7) (when external memory is accessed)

4.2 Non-Port Pins (2/2)

Pin Name	I/O	Alternate Function	Function
CLKOUT	Output	ASTB	Clock output
PWM0	Output	—	PWM output 0
PWM1	Output	—	PWM output 1
$\overline{RX}$	Input	—	Data input (IEBus)
$\overline{TX}$	Output	—	Data output (IEBus)
REGC	—	—	Connecting capacitor for regulation output stabilization/power supply when regulator is stopped
REGOFF	—	—	Regulator operation specification signal
$\overline{RESET}$	Input	—	Chip reset
X1	Input	—	Connecting crystal resonator for system clock oscillation (clock can be also input to X1.)
X2	—		
XT1	Input	—	Watch clock connection
XT2	—	—	
ANI0 to ANI7	Input	P70 to P77	Analog voltage input for A/D converter
$AV_{REF1}$	—	—	Application of reference voltage for A/D converter
$AV_{DD}$			Positive power supply for A/D converter
$AV_{SS}$			GND for A/D converter
$V_{DD}$			Positive power supply
$V_{SS}$			GND
$V_{PP}$			Input

**4.3 Pin I/O Circuits and Recommended Connection of Unused Pins**

The I/O circuit type of each pin and recommended connection of unused pins are shown in Table 4-1.

For the I/O circuit configuration of each type, refer to **Figure 4-1**.

**Table 4-1. Types of Pin I/O Circuits and Recommended Connection of Unused Pins (1/2)**

Pin Name	I/O Circuit Type	I/O	Recommended Connection of Unused Pins			
P00 to P07	5-A	I/O	Input: Connect to V <sub>DD</sub> . Output: Leave open.			
P10, P11						
P12/ASCK2/SCK2						
P13/RxD2/SI2						
P14/TxD2/SO2						
P15 to P17						
P20/NMI	2	Input	Connect to V <sub>DD</sub> or V <sub>SS</sub> .			
P21/INTP0						
P22/INTP1				2-A	Connect to V <sub>DD</sub> .	
P23/INTP2/CI						
P24/INTP3						
P25/INTP4/ASCK/SCK1	8-A	I/O	Input: Connect to V <sub>DD</sub> . Output: Leave open.			
P26/INTP5	2-A	Input	Connect to V <sub>DD</sub> .			
P27/SI0						
P30/RxD/SI1	5-A	I/O	Input: Connect to V <sub>DD</sub> . Output: Leave open.			
P31/TxD/SO1						
P32/SCK0	10-A					
P33/SO0						
P34/TO0 to P37/TO3	5-A					
P40/AD0 to P47/AD7						
P50/A8 to P57/A15						
P60/A16 to P63/A19						
P64/RD						
P65/WR						
P66/WAIT/HLD RQ						
P67/REFRQ/HLDAK						
P70/ANI0 to P77/ANI7				20	I/O	Input: Connect to V <sub>DD</sub> or V <sub>SS</sub> . Output: Leave open.
P90 to P97						
P100 to P104						
P105/SCK3						
P106/SI3						
P107/SO3						
ASTB/CLKOUT	4	Output	Leave open.			
RESET	2	Input	—			
V <sub>PP</sub>	1		Connect directly to V <sub>SS</sub> .			
XT2	—	—	Leave open.			
XT1	—	Input	Connect directly to V <sub>SS</sub> .			

**Table 4-1. Types of Pin I/O Circuits and Recommended Connection of Unused Pins (2/2)**

Pin Name	I/O Circuit Type	I/O	Recommended Connection of Unused Pins
REGOFF	1	—	Connect directly to V <sub>DD</sub> .
REGC	—	—	Connect to V <sub>DD</sub> .
PWM0, PWM1	3	Output	Leave open.
$\overline{RX}$	1	Input	Connect to V <sub>DD</sub> or V <sub>SS</sub> .
$\overline{TX}$	3	Output	Leave open.
AV <sub>REF1</sub>	—	—	Connect to V <sub>SS</sub> .
AV <sub>SS</sub>			
AV <sub>DD</sub>			Connect to V <sub>DD</sub> .

**Caution** Connect an I/O pin to V<sub>DD</sub> via a resistor of several 10 kΩ if the I/O mode of the pin is unstable (especially if the voltage on the reset pin is higher than the low-level input voltage on power application or if the mode is changed between input and output by software).

**Remark** The circuit type numbers are common for the 78K Series and are not always sequential for one product (some circuits are not provided).

Figure 4-1. Pin I/O Circuits (1/2)

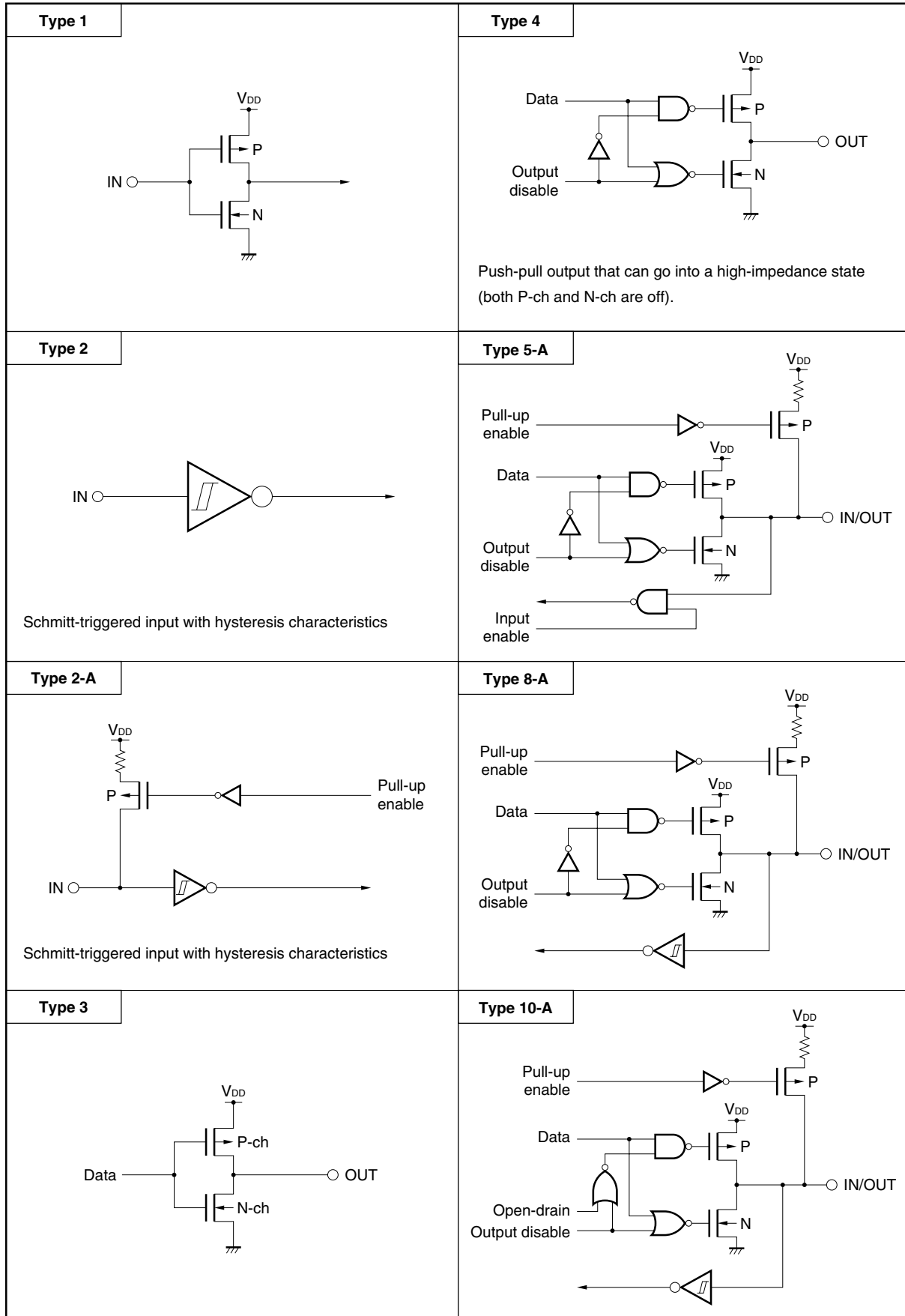
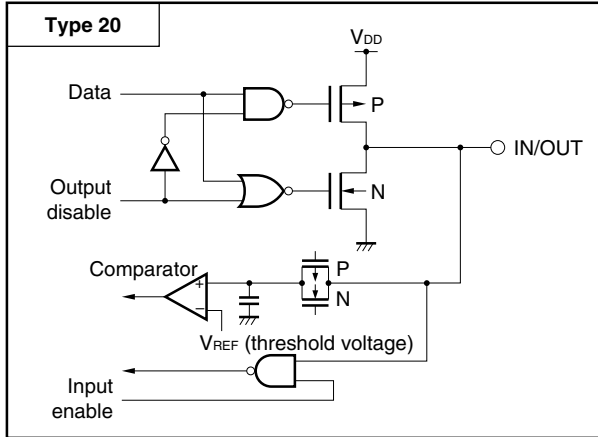



Figure 4-1. Pin I/O Circuits (2/2)



### 5. INTERNAL MEMORY SIZE SWITCHING REGISTER (IMS)

IMS is a register to prevent a certain part of the internal memory from being used by software. By setting the IMS, it is possible to establish a memory map that is the same as that of mask ROM version with a different internal memory (ROM, RAM) capacity.

IMS is set with an 8-bit memory manipulation instruction.

$\overline{\text{RESET}}$  input sets IMS to FFH.

**Figure 5-1. Internal Memory Size Switching Register (IMS) Format**

Address	0FFFCH	After reset	FFH	W					
Symbol	7	6	5	4	3	2	1	0	
IMS	1	1	ROM1	ROM0	1	1	RAM1	RAM0	

ROM1	ROM0	Internal ROM Capacity Selection
0	0	256 KB
0	1	96 KB
1	0	128 KB
1	1	192 KB

RAM1	RAM0	Internal RAM Capacity Selection
0	0	10496 bytes
0	1	5120 bytes
1	0	6656 bytes
1	1	8192 bytes

**Caution** IMS is not available for mask ROM versions (μPD784935A, 784936A, 784937A, and 784938A).

The IMS settings to create the same memory map as mask ROM versions are shown in Table 5-1.

**Table 5-1. Internal Memory Size Switching Register (IMS) Settings**

Relevant Mask ROM Version	IMS Setting
μPD784935A	DDH
μPD784936A	EEH
μPD784937A	FFH
μPD784938A	CCH

**Note** Shifting to the flash memory programming mode sets all pins not used for flash memory programming to the same state as immediately after reset. Therefore, if the external devices do not acknowledge the port state immediately after reset, handling such as connecting to V<sub>DD</sub> via a resistor or connecting to V<sub>SS</sub> via a resistor is required.

## 6. PROGRAMMING FLASH MEMORY

Flash memory can be written while mounted on the target system (on-board writing). Connect the dedicated flash programmer (Flashpro III (part No.: FL-PR3, PG-FP3)) to the host machine and target system for programming. Moreover, writing to flash memory can also be performed using a flash memory writing adapter connected to Flashpro III.

**Remark** FL-PR3 is a product of Naito Densai Machida Mfg. Co., Ltd.

### 6.1 Selecting Communication Mode

The Flashpro III is used to write data into a flash memory by serial communications. Select the communication mode for writing from Table 6-1. Figure 6-1 shows the format used to select the communication mode. Each communication mode is selected with the number of  $V_{PP}$  pulses shown in Table 6-1.

**Table 6-1. Communication Mode**

Communication Mode	Number of Channels	Pins Used	Number of $V_{PP}$ Pulses
3-wire serial I/O	3	SCK3/P105 SI3/P106 SO3/P107	1
		SCK0/P32 SI0/P27 SO0/P33	0
		SCK3/P105 SI3/P106 SO3/P107 P104 (for handshake)	3
UART	1	RxD/P30 TxD/P31	8

**Caution** Always select the communication mode using the number of  $V_{PP}$  pulses shown in Table 6-1.

**Figure 6-1. Communication Mode Selection Format**

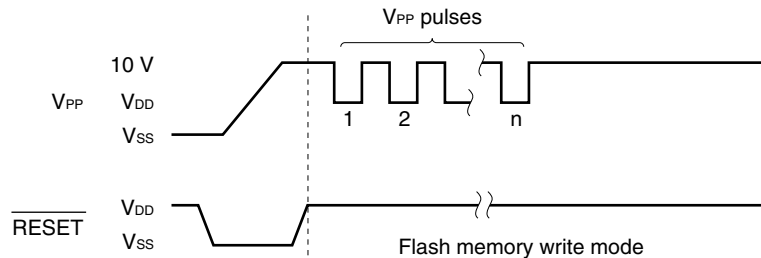

## 6.2 Flash Memory Programming Functions

By transmitting and receiving various commands and data by the selected communication mode, operations such as writing to the flash memory are performed. Table 6-2 shows the major functions.

**Table 6-2. Flash Memory Programming Functions**

Function	Description
Area erase	Erase the contents of the specified memory area where one memory block is 16 KB.
Area blank check	Checks the erase state of the specified area.
Data write	Writes to the flash memory based on the start write address and the number of data written (number of bytes).
Area verify	Compares the data input with the contents of the specified memory area.

Verification for the flash memory entails supplying the data to be verified from an external source via a serial interface, and then outputting the existence of unmatched data to the external source after referencing the areas or all of the data. Consequently, the flash memory is not equipped with a read function, and it is not possible for third parties to read the contents of the flash memory with the use of the verification function.

### 6.3 Connecting Flashpro III

The connection between the Flashpro III and the μPD78F4938A differs depending on the communication mode (3-wire serial I/O or UART). Figures 6-2 and 6-3 are the connection diagrams in each case.

**Figure 6-2. Flashpro III Connection in 3-Wire Serial I/O Mode**

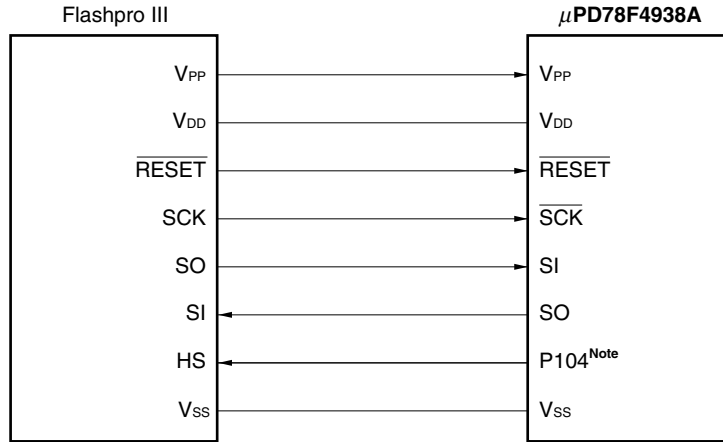

**Note** Only in the handshake communication

**Figure 6-3. Flashpro III Connection in UART Mode**

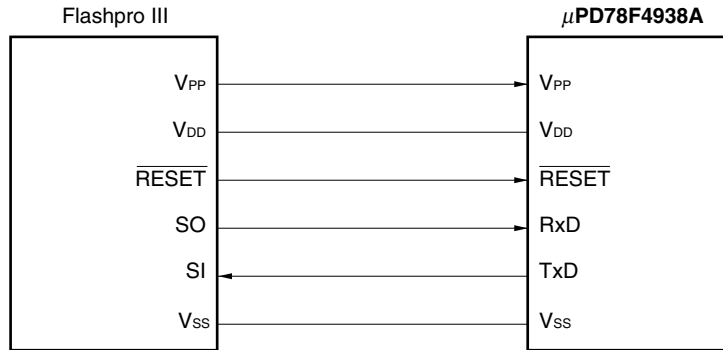

7. ELECTRICAL SPECIFICATIONS

Absolute Maximum Ratings (T<sub>A</sub> = 25°C)

Parameter	Symbol	Conditions	Ratings	Unit
Supply voltage	V <sub>DD</sub>		-0.3 to +6.5	V
	AV <sub>DD</sub>		-0.3 to V <sub>DD</sub> + 0.3	V
	AV <sub>SS</sub>		-0.3 to V <sub>SS</sub> + 0.3	V
	AV <sub>REF1</sub>	A/D converter reference voltage input	-0.3 to V <sub>DD</sub> + 0.3	V
Input voltage	V <sub>I2</sub>		-0.3 to +10.5	V
Analog input voltage	V <sub>IAN</sub>	Analog input voltage	AV <sub>SS</sub> - 0.3 to AV <sub>REF1</sub> + 0.3	V
Output voltage	V <sub>O</sub>		-0.3 to V <sub>DD</sub> + 0.3	V
Output current, low	I <sub>OL</sub>	Per pin	10	mA
		Total for all pins of ports 0, 3, 6, 10 and P54 to P57	50	mA
		Total for all pins of ports 1, 4, 7, 9, P50 to P53, PWM0, PWM1, and TX pins	50	mA
Output current, high	I <sub>OH</sub>	Per pin	-6	mA
		Total for all pins of ports 0, 3, 6, 10, and P54 to P57	-30	mA
		Total for all pins of ports 1, 4, 7, 9, P50 to P53, PWM0, PWM1, and TX pins	-30	mA
Operating ambient temperature	T <sub>A</sub>		-40 to +85	°C
Storage temperature	T <sub>stg</sub>		-40 to +150	°C

**Caution** Product quality may suffer if the absolute maximum rating is exceeded even momentarily for any parameter. That is, the absolute maximum ratings are rated values at which the product is on the verge of suffering physical damage, and therefore the product must be used under conditions that ensure that the absolute maximum ratings are not exceeded.

**Remark** Unless specified otherwise, the characteristics of alternate-function pins are the same as those of port pins.

**Operating Conditions**

- Clock frequency

Clock Frequency	Supply Voltage
4 MHz ≤ f <sub>xx</sub> ≤ 12.58 MHz	4.0 ≤ V <sub>DD</sub> ≤ 5.5 V
4 MHz ≤ f <sub>xx</sub> ≤ 6.29 MHz	3.0 ≤ V <sub>DD</sub> ≤ 5.5 V

- Operating ambient temperature (T<sub>A</sub>): -40 to +85°C
- Power supply voltage and clock cycle time: Refer to **Figure 7-1**
- Selection of internal regulator operation (REGOFF pin: low-level input)

**Figure 7-1. Power Supply Voltage and Clock Cycle Time**

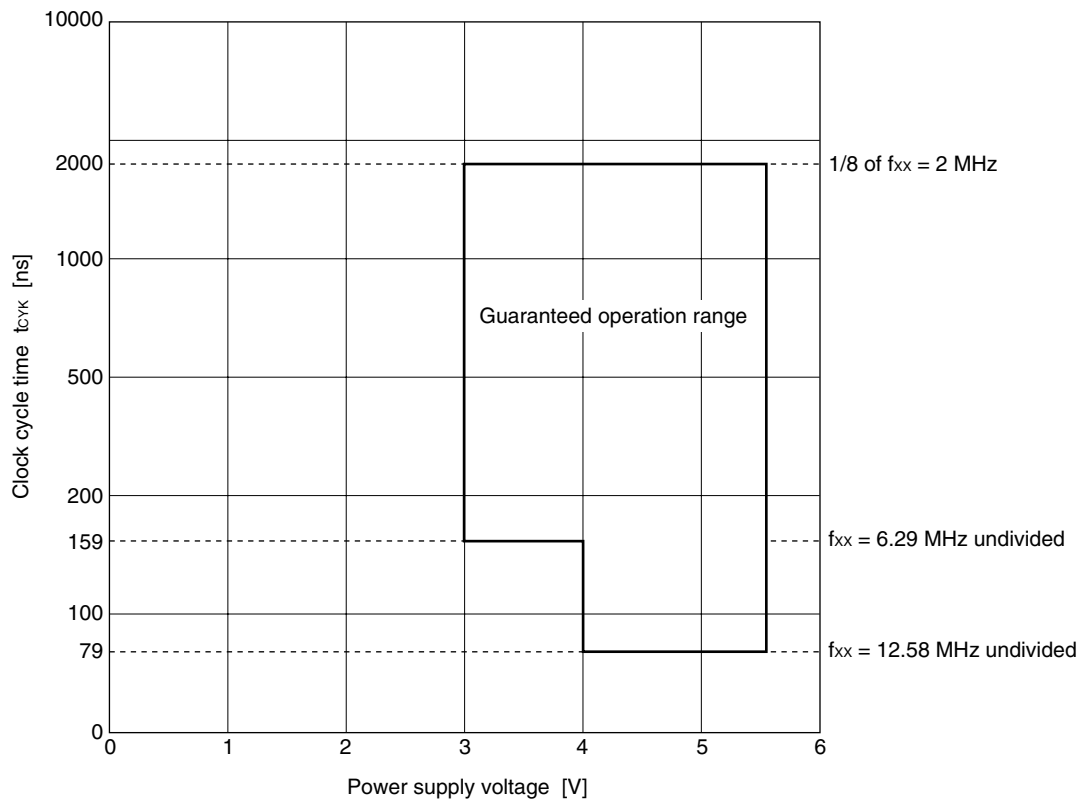

**Capacitance (T<sub>A</sub> = 25°C, V<sub>DD</sub> = V<sub>SS</sub> = 0 V)**

Parameter	Symbol	Conditions	MIN.	TYP.	MAX.	Unit
Input capacitance	C <sub>IN</sub>	f = 1 MHz			15	pF
Output capacitance	C <sub>OUT</sub>	Unmeasured pins returned to 0 V.			15	pF
I/O capacitance	C <sub>IO</sub>				15	pF

**Main Oscillator Characteristics (T<sub>A</sub> = -40 to +85°C, V<sub>DD</sub> = 3.0 to 5.5 V, V<sub>SS</sub> = 0 V)**

Parameter	Symbol	Conditions	MIN.	MAX.	Unit	
Oscillator frequency	f <sub>xx</sub>	Ceramic resonator or recommended resonator	4.0 ≤ V <sub>DD</sub> ≤ 5.5 V	4.0	12.58	MHz
			3.0 ≤ V <sub>DD</sub> ≤ 5.5 V	4.0	6.29	MHz

**Caution** When using the main clock oscillator, wire as follows to avoid an adverse effect from wiring capacitance.

- Keep the wiring length as short as possible.
- Do not cross the wiring with the other signal lines.
- Do not route the wiring near a signal line through which a high fluctuating current flows.
- Always make the ground point of the oscillator capacitor the same potential as V<sub>SS</sub>.
- Do not ground the capacitor to a ground pattern through which a high current flows.
- Do not fetch signals from the oscillator.

- Remarks**
1. Connect a 12.582912 MHz or 6.291456 MHz oscillator to operate the internal clock timer with the main clock.
  2. For the resonator selection and oscillator constant, customers are requested to either evaluate the oscillation themselves or apply to the resonator manufacturer for evaluation.

**Clock Oscillator Characteristics (T<sub>A</sub> = -40 to +85°C, V<sub>DD</sub> = 3.0 to 5.5 V, V<sub>SS</sub> = 0 V)**

Parameter	Symbol	Conditions	MIN.	TYP.	MAX.	Unit
Oscillator frequency	f <sub>XT</sub>	Ceramic resonator or crystal resonator	32	32.768	35	kHz
Oscillation stabilization time	f <sub>sxt</sub>	4.5 ≤ V <sub>DD</sub> ≤ 5.5 V		1.2	2	s
					10	s
Oscillation hold voltage	V <sub>DDXT</sub>		3.0		5.5	V
Watch timer operating voltage	V <sub>DDW</sub>		3.0		5.5	V



DC Characteristics (T<sub>A</sub> = -40 to +85°C, V<sub>DD</sub> = AV<sub>DD</sub> = 3.0 to 5.5 V, V<sub>SS</sub> = AV<sub>SS</sub> = 0 V) (1/2)

Parameter	Symbol	Conditions	MIN.	TYP.	MAX.	Unit
Input voltage, low <sup>Note</sup>	V <sub>IL1</sub>	P10, P11, P13 to P17, P30, P31, P34 to P37, P70 to P77, P90 to P97, P100 to P104, X1, X2, XT1, XT2	-0.3		0.3V <sub>DD</sub>	V
	V <sub>IL2</sub>	P12, P20 to P27, P32, P33, P105 to P107 RESET	-0.3		0.2V <sub>DD</sub>	V
	V <sub>IL3</sub>	P00 to P07, P40 to P47, 4.5 ≤ V <sub>DD</sub> ≤ 5.5 V	-0.3		0.8	V
	V <sub>IL4</sub>	P50 to P57, P60 to P67	-0.3		0.2V <sub>DD</sub>	V
Input voltage, high	V <sub>IH1</sub>	P10, P11, P13 to P17, P30, P31, P34 to P37, P70 to P77, P90 to P97, P100 to P104, X1, X2, XT1, XT2	0.7V <sub>DD</sub>		V <sub>DD</sub> +0.3	V
	V <sub>IH2</sub>	P12, P20 to P27, P32, P33, P105 to P107 RESET	0.8V <sub>DD</sub>		V <sub>DD</sub> +0.3	V
	V <sub>IH3</sub>	P00 to P07, P40 to P47, 4.5 ≤ V <sub>DD</sub> ≤ 5.5 V	2.2		V <sub>DD</sub> +0.3	V
	V <sub>IH4</sub>	P50 to P57, P60 to P67	0.7V <sub>DD</sub>		0.3V <sub>DD</sub>	V
Output voltage, low	V <sub>OL1</sub>	I <sub>OL</sub> = 20 μA			0.1	V
		I <sub>OL</sub> = 100 μA			0.2	V
		I <sub>OL</sub> = 2 mA			0.4	V
	V <sub>OL2</sub>	I <sub>OL</sub> = 8 mA, P10 to P17, P40 to P47, P50 to P57, 4.5 ≤ V <sub>DD</sub> ≤ 5.5 V			1.0	V
Output voltage, high	V <sub>OH1</sub>	I <sub>OH</sub> = -20 μA	V <sub>DD</sub> -0.1			V
		I <sub>OH</sub> = -100 μA	V <sub>DD</sub> -0.2			V
		I <sub>OH</sub> = -2 mA	V <sub>DD</sub> -1.0			V
	V <sub>OH2</sub>	I <sub>OL</sub> = -5 mA, P10 to P17, P40 to P47, P50 to P57, 4.5 V ≤ V <sub>DD</sub> ≤ 5.5 V	V <sub>DD</sub> -2.4			V
Input leakage current, low	I <sub>LIL1</sub>	V <sub>IN</sub> = 0 V			10	μA
	I <sub>LIL2</sub>		For pins other than X1, X2, XT1, and XT2		-20	μA
Input leakage current, high	I <sub>LIH1</sub>	V <sub>IN</sub> = V <sub>DD</sub>			10	μA
	I <sub>LIH2</sub>		For pins other than X1, X2, XT1, and XT2		20	μA
Output leakage current, low	I <sub>LOL1</sub>	V <sub>OUT</sub> = 0 V			-10	μA
Output leakage current, high	I <sub>LOH1</sub>	V <sub>OUT</sub> = V <sub>DD</sub>			10	μA

**Note** These values are valid when the pull-up resistor is off.

DC Characteristics (T<sub>A</sub> = -40 to +85°C, V<sub>DD</sub> = AV<sub>DD</sub> = 3.0 to 5.5 V, V<sub>SS</sub> = AV<sub>SS</sub> = 0 V) (2/2)

Parameter	Symbol	Conditions		MIN.	TYP.	MAX.	Unit
Power supply current	I <sub>DD1</sub>	Operating mode	f <sub>XX</sub> = 12.58 MHz, 4.0 V ≤ V <sub>DD</sub> ≤ 5.5 V		19	38	mA
			f <sub>XX</sub> = 6.29 MHz, 3.0 V ≤ V <sub>DD</sub> ≤ 5.5 V		10	20	mA
	I <sub>DD2</sub>	HALT mode	f <sub>XX</sub> = 12.58 MHz, when peripheral clock stops <sup>Note</sup> , 4.0 V ≤ V <sub>DD</sub> ≤ 5.5 V		3	6	mA
			f <sub>XX</sub> = 6.29 MHz, when peripheral clock stops <sup>Note</sup> , 3.0 V ≤ V <sub>DD</sub> ≤ 5.5 V		1.8	3.6	mA
	I <sub>DD3</sub>	IDLE mode	f <sub>XX</sub> = 12.58 MHz, 4.0 ≤ V <sub>DD</sub> ≤ 5.5 V		2	4	mA
			f <sub>XX</sub> = 6.29 MHz, 3.0 V ≤ V <sub>DD</sub> ≤ 5.5 V		1	2	mA
Data hold voltage	V <sub>DDDR</sub>	STOP mode		2.5		5.5	V
Data hold current	I <sub>DDDR</sub>	STOP mode	V <sub>DD</sub> = 2.5 V, subsystem clock stops		4	20	μA
			V <sub>DD</sub> = 5.5 V, subsystem clock stops		20	100	μA
Pull-up resistor	R <sub>L</sub>	V <sub>IN</sub> = 0 V		15	40	80	kΩ

**Note** When the main system clock: f<sub>CLK</sub> = f<sub>XX</sub>/8 is selected (set by the standby control register (STBC)) and the watch timer is operating.

**Remark** These values are valid when the internal regulator is on (REGOFF pin = low-level input).

AC Characteristics (T<sub>A</sub> = -40 to +85°C, V<sub>DD</sub> = AV<sub>DD</sub> = 3.0 to 5.5 V, V<sub>SS</sub> = AV<sub>SS</sub> = 0 V)

(1) Read/write operation (1/2)

Parameter	Symbol	Conditions	MIN.	TYP.	MAX.	Unit
Cycle time	t <sub>CYK</sub>	4.0 ≤ V <sub>DD</sub> ≤ 5.5 V	79			ns
		V <sub>DD</sub> = 3.0 V	159			ns
Address setup time (to ASTB↓)	t <sub>SAST</sub>	V <sub>DD</sub> = 5.0 V	(0.5+a) T-11			ns
		V <sub>DD</sub> = 3.0 V	(0.5+a) T-15			ns
Address hold time (from ASTB↓)	t <sub>HSTLA</sub>	V <sub>DD</sub> = 5.0 V	0.5T-19			ns
		V <sub>DD</sub> = 3.0 V	0.5T-24			ns
ASTB high-level width	t <sub>WSTH</sub>	V <sub>DD</sub> = 5.0 V	(0.5+a) T-17			ns
		V <sub>DD</sub> = 3.0 V	(0.5+a) T-40			ns
Address hold time (from $\overline{RD}\uparrow$ )	t <sub>HRA</sub>	V <sub>DD</sub> = 5.0 V	0.5T-14			ns
		V <sub>DD</sub> = 3.0 V	0.5T-14			ns
Delay time from address to $\overline{RD}\downarrow$	t <sub>DAR</sub>	V <sub>DD</sub> = 5.0 V	(1+a) T-5			ns
		V <sub>DD</sub> = 3.0 V	(1+a) T-10			ns
Address float time (from $\overline{RD}\downarrow$ )	t <sub>FAR</sub>				0	ns
Data input time from address	t <sub>DAID</sub>	V <sub>DD</sub> = 5.0 V			(2.5+a+n) T-37	ns
		V <sub>DD</sub> = 3.0 V			(2.5+a+n) T-52	ns
Data input time from ASTB↓	t <sub>DSTID</sub>	V <sub>DD</sub> = 5.0 V			(2+n) T-35	ns
		V <sub>DD</sub> = 3.0 V			(2+n) T-50	ns
Data input time from $\overline{RD}\downarrow$	t <sub>DRID</sub>	V <sub>DD</sub> = 5.0 V			(1.5+n) T-40	ns
		V <sub>DD</sub> = 3.0 V			(1.5+n) T-50	ns
Delay time from ASTB ↓ to $\overline{RD}\downarrow$	t <sub>DSTR</sub>	V <sub>DD</sub> = 5.0 V	0.5T-9			ns
		V <sub>DD</sub> = 3.0 V	0.5T-9			ns
Data hold time (from $\overline{RD}\uparrow$ )	t <sub>HRID</sub>		0			ns
Address active time from $\overline{RD}\uparrow$	t <sub>DRA</sub>	V <sub>DD</sub> = 5.0 V	0.5T-2			ns
		V <sub>DD</sub> = 3.0 V	0.5T-12			ns
Delay time from $\overline{RD}\uparrow$ to ASTB↑	t <sub>DRST</sub>	V <sub>DD</sub> = 5.0 V	0.5T-9			ns
		V <sub>DD</sub> = 3.0 V	0.5T-9			ns
$\overline{RD}$ low-level width	t <sub>WRL</sub>	V <sub>DD</sub> = 5.0 V	(1.5+n) T-25			ns
		V <sub>DD</sub> = 3.0 V	(1.5+n) T-30			ns

- Remarks**
1. T: t<sub>CYK</sub> = 1/f<sub>CLK</sub> (f<sub>CLK</sub>: internal system clock)
  2. a: 1 during address wait; otherwise 0
  3. n: Number of wait states (n ≥ 0)
  4. Calculated as T = 79 ns (min.) @ V<sub>DD</sub> = 5.0 V
  5. Calculated as T = 159 ns (min.) @ V<sub>DD</sub> = 3.0 V

AC Characteristics (T<sub>A</sub> = -40 to +85°C, V<sub>DD</sub> = AV<sub>DD</sub> = 3.0 to 5.5 V, V<sub>SS</sub> = AV<sub>SS</sub> = 0 V)

(1) Read/write operation (2/2)

Parameter	Symbol	Conditions	MIN.	TYP.	MAX.	Unit
Delay time from address to $\overline{WR}\downarrow$	t <sub>DAW</sub>	V <sub>DD</sub> = 5.0 V	(1+a) T-5			ns
		V <sub>DD</sub> = 3.0 V	(1+a) T-10			ns
Address hold time (from $\overline{WR}\uparrow$ )	t <sub>HWA</sub>	V <sub>DD</sub> = 5.0 V	0.5T-14			ns
		V <sub>DD</sub> = 3.0 V	0.5T-14			ns
Delay time from ASTB ↓ to data output	t <sub>DSTOD</sub>	V <sub>DD</sub> = 5.0 V			0.5T+15	ns
		V <sub>DD</sub> = 3.0 V			0.5T+20	ns
Data output time from $\overline{WR}\downarrow$	t <sub>DWOD</sub>				15	ns
Delay time from ASTB ↓ to $\overline{WR}\downarrow$	t <sub>DSTW</sub>	V <sub>DD</sub> = 5.0 V	0.5T-9			ns
		V <sub>DD</sub> = 3.0 V	0.5T-9			ns
Data setup time (to $\overline{WR}\uparrow$ )	t <sub>SODWR</sub>	V <sub>DD</sub> = 5.0 V	(1.5+n) T-20			ns
		V <sub>DD</sub> = 3.0 V	(1.5+n) T-25			ns
Data hold time (from $\overline{WR}\uparrow$ )	t <sub>HWOD</sub>	V <sub>DD</sub> = 5.0 V	0.5T-14			ns
		V <sub>DD</sub> = 3.0 V	0.5T-14			ns
Delay time from $\overline{WR}\uparrow$ to ASTB ↑	t <sub>DWST</sub>	V <sub>DD</sub> = 5.0 V	0.5T-9			ns
		V <sub>DD</sub> = 3.0 V	0.5T-9			ns
$\overline{WR}$ low-level width	t <sub>WWL</sub>	V <sub>DD</sub> = 5.0 V	(1.5+n) T-25			ns
		V <sub>DD</sub> = 3.0 V	(1.5+n) T-30			ns

- Remarks**
1. T: t<sub>CYK</sub> = 1/f<sub>CLK</sub> (f<sub>CLK</sub>: internal system clock)
  2. a: 1 during address wait; otherwise 0
  3. n: Number of wait states (n ≥ 0)
  4. Calculated as T = 79 ns (min.) @ V<sub>DD</sub> = 5.0 V
  5. Calculated as T = 159 ns (min.) @ V<sub>DD</sub> = 3.0 V

AC Characteristics (T<sub>A</sub> = -40 to +85°C, V<sub>DD</sub> = AV<sub>DD</sub> = 3.0 to 5.5 V, V<sub>SS</sub> = AV<sub>SS</sub> = 0 V)

(2) External wait timing

Parameter	Symbol	Conditions	MIN.	TYP.	MAX.	Unit
$\overline{\text{WAIT}}\downarrow$ input time from address	t <sub>DAWT</sub>	V <sub>DD</sub> = 5.0 V			(2+a) T-40	ns
		V <sub>DD</sub> = 3.0 V			(2+a) T-60	ns
$\overline{\text{WAIT}}\downarrow$ input time from ASTB $\downarrow$	t <sub>DSTWT</sub>	V <sub>DD</sub> = 5.0 V			1.5T-40	ns
		V <sub>DD</sub> = 3.0 V			1.5T-60	ns
$\overline{\text{WAIT}}$ hold time from ASTB $\downarrow$	t <sub>HSTWTH</sub>	V <sub>DD</sub> = 5.0 V	(0.5+n) T+5			ns
		V <sub>DD</sub> = 3.0 V	(0.5+n) T+10			ns
Delay time from ASTB $\downarrow$ to $\overline{\text{WAIT}}\uparrow$	t <sub>DSTWTH</sub>	V <sub>DD</sub> = 5.0 V			(1.5+a) T-40	ns
		V <sub>DD</sub> = 3.0 V			(1.5+a) T-60	ns
$\overline{\text{WAIT}}\downarrow$ input time from $\overline{\text{RD}}\downarrow$	t <sub>DRWTL</sub>	V <sub>DD</sub> = 5.0 V			T-40	ns
		V <sub>DD</sub> = 3.0 V			T-60	ns
$\overline{\text{WAIT}}$ hold time from $\overline{\text{RD}}\downarrow$	t <sub>HRWT</sub>	V <sub>DD</sub> = 5.0 V	nT+5			ns
		V <sub>DD</sub> = 3.0 V	nT+10			ns
Delay time from $\overline{\text{RD}}\downarrow$ to $\overline{\text{WAIT}}\uparrow$	t <sub>DRWTH</sub>	V <sub>DD</sub> = 5.0 V			(1+n) T-40	ns
		V <sub>DD</sub> = 3.0 V			(1+n) T-60	ns
Data input time from $\overline{\text{WAIT}}\uparrow$	t <sub>DWTID</sub>	V <sub>DD</sub> = 5.0 V			0.5T-5	ns
		V <sub>DD</sub> = 3.0 V			0.5T-10	ns
Delay time from $\overline{\text{WAIT}}\uparrow$ to $\overline{\text{RD}}\uparrow$	t <sub>DWTR</sub>	V <sub>DD</sub> = 5.0 V	0.5T			ns
		V <sub>DD</sub> = 3.0 V	0.5T			ns
Delay time from $\overline{\text{WAIT}}\uparrow$ to $\overline{\text{WR}}\uparrow$	t <sub>DWTW</sub>	V <sub>DD</sub> = 5.0 V	0.5T			ns
		V <sub>DD</sub> = 3.0 V	0.5T			ns
$\overline{\text{WAIT}}\downarrow$ input time from $\overline{\text{WR}}\downarrow$	t <sub>DWWTL</sub>	V <sub>DD</sub> = 5.0 V			T-40	ns
		V <sub>DD</sub> = 3.0 V			T-60	ns
$\overline{\text{WAIT}}$ hold time from $\overline{\text{WR}}\downarrow$	t <sub>HWWT</sub>	V <sub>DD</sub> = 5.0 V	nT+5			ns
		V <sub>DD</sub> = 3.0 V	nT+10			ns
Delay time from $\overline{\text{WR}}\downarrow$ to $\overline{\text{WAIT}}\uparrow$	t <sub>DWWTH</sub>	V <sub>DD</sub> = 5.0 V			(1+n) T-40	ns
		V <sub>DD</sub> = 3.0 V			(1+n) T-60	ns

- Remarks**
1. T: t<sub>CYK</sub> = 1/f<sub>CLK</sub> (f<sub>CLK</sub>: internal system clock)
  2. a: 1 during address wait; otherwise 0
  3. n: Number of wait states (n ≥ 0)
  4. Calculated as T = 79 ns (min.) @ V<sub>DD</sub> = 5.0 V
  5. Calculated as T = 159 ns (min.) @ V<sub>DD</sub> = 3.0 V

AC Characteristics (T<sub>A</sub> = -40 to +85°C, V<sub>DD</sub> = AV<sub>DD</sub> = 3.0 to 5.5 V, V<sub>SS</sub> = AV<sub>SS</sub> = 0 V)

(3) Bus hold/refresh timing

Parameter	Symbol	Conditions	MIN.	TYP.	MAX.	Unit
Delay time from HLDRQ↑ to float	t <sub>FHQC</sub>	V <sub>DD</sub> = 5.0 V			(2+4+a+n) T+50	ns
		V <sub>DD</sub> = 3.0 V			(2+4+a+n) T+50	ns
Delay time from HLDRQ↑ to HLDAC↑	t <sub>DHQHHAH</sub>	V <sub>DD</sub> = 5.0 V			(3+4+a+n) T+30	ns
		V <sub>DD</sub> = 3.0 V			(3+4+a+n) T+40	ns
Delay time from float to HLDAC↑	t <sub>DCFHA</sub>	V <sub>DD</sub> = 5.0 V			T+30	ns
		V <sub>DD</sub> = 3.0 V			T+30	ns
Delay time from HLDRQ↓ to HLDAC↓	t <sub>DHQLHAL</sub>	V <sub>DD</sub> = 5.0 V			2T+40	ns
		V <sub>DD</sub> = 3.0 V			2T+60	ns
Delay time from HLDAC↓ to active	t <sub>DHAC</sub>	V <sub>DD</sub> = 5.0 V	T-20			ns
		V <sub>DD</sub> = 3.0 V	T-30			ns
Random read/write cycle time	t <sub>RC</sub>	V <sub>DD</sub> = 5.0 V	3T			ns
		V <sub>DD</sub> = 3.0 V	3T			ns
REFRQ low-level pulse width	t <sub>WRFQL</sub>	V <sub>DD</sub> = 5.0 V	1.5T-25			ns
		V <sub>DD</sub> = 3.0 V	1.5T-30			ns
Delay time from ASTB↓ to REFRQ	t <sub>DSTRFQ</sub>	V <sub>DD</sub> = 5.0 V	0.5T-9			ns
		V <sub>DD</sub> = 3.0 V	0.5T-9			ns
Delay time from RD↑ to REFRQ	t <sub>DRRFQ</sub>	V <sub>DD</sub> = 5.0 V	1.5T-9			ns
		V <sub>DD</sub> = 3.0 V	1.5T-9			ns
Delay time from WR↑ to REFRQ	t <sub>DWRFQ</sub>	V <sub>DD</sub> = 5.0 V	1.5T-9			ns
		V <sub>DD</sub> = 3.0 V	1.5T-9			ns
Delay time from REFRQ↑ to ASTB	t <sub>DRFQST</sub>	V <sub>DD</sub> = 5.0 V	0.5T-9			ns
		V <sub>DD</sub> = 3.0 V	0.5T-9			ns
REFRQ high-level pulse width	t <sub>WRFQH</sub>	V <sub>DD</sub> = 5.0 V	1.5T-25			ns
		V <sub>DD</sub> = 3.0 V	1.5T-30			ns

- Remarks**
1. T: t<sub>CYK</sub> = 1/f<sub>CLK</sub> (f<sub>CLK</sub>: internal system clock)
  2. a: 1 during address wait; otherwise 0
  3. n: Number of wait states (n ≥ 0)
  4. Calculated as T = 79 ns (min.) @ V<sub>DD</sub> = 5.0 V
  5. Calculated as T = 159 ns (min.) @ V<sub>DD</sub> = 3.0 V

Timing Waveform

(1) Read operation

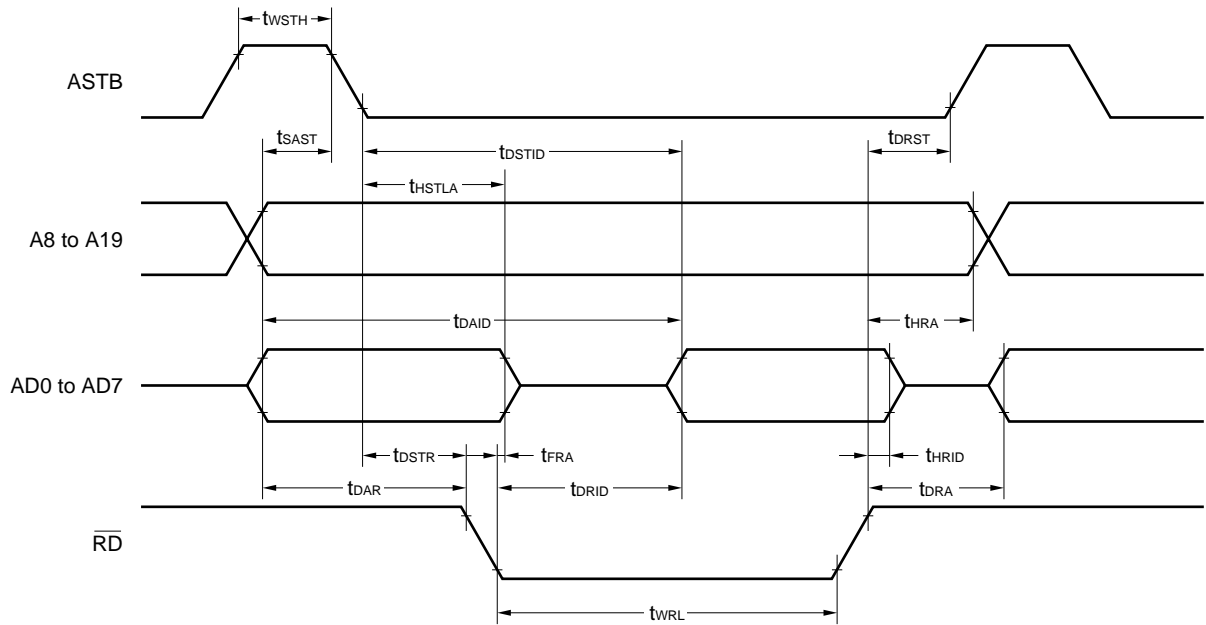

(2) Write operation

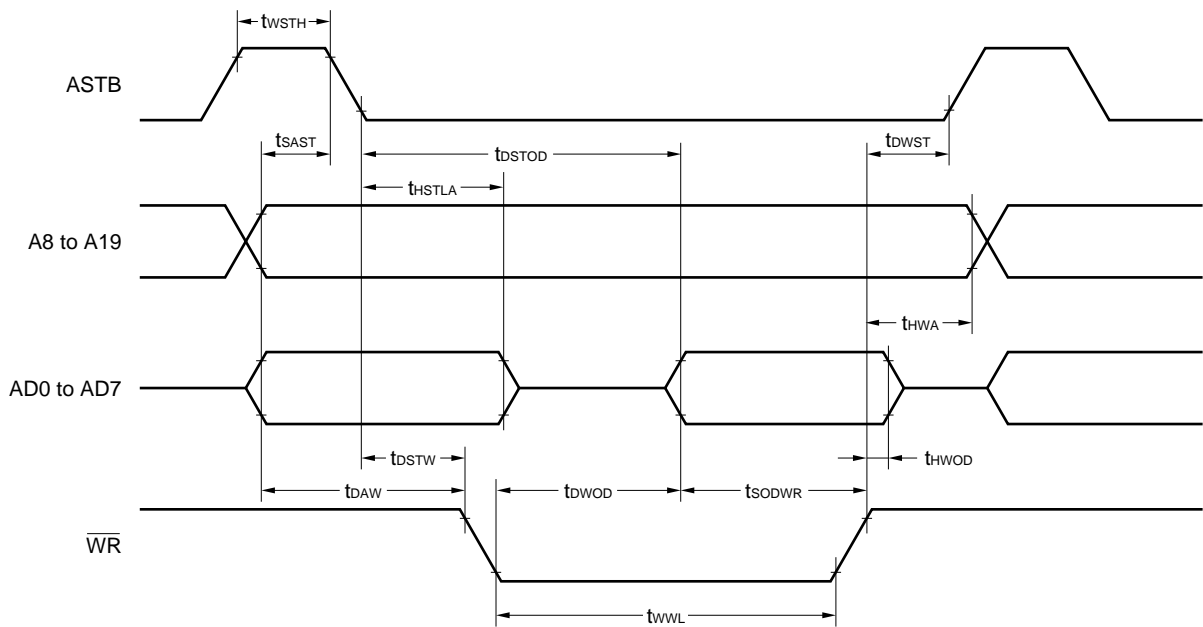

Hold Timing

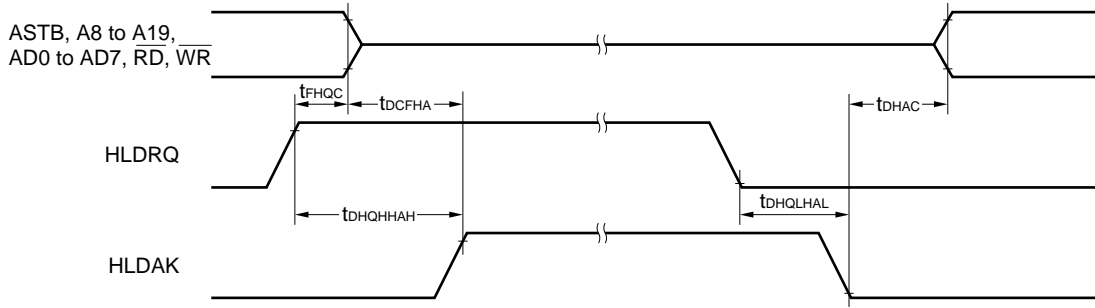

External Wait Signal Input Timing

(1) Read operation

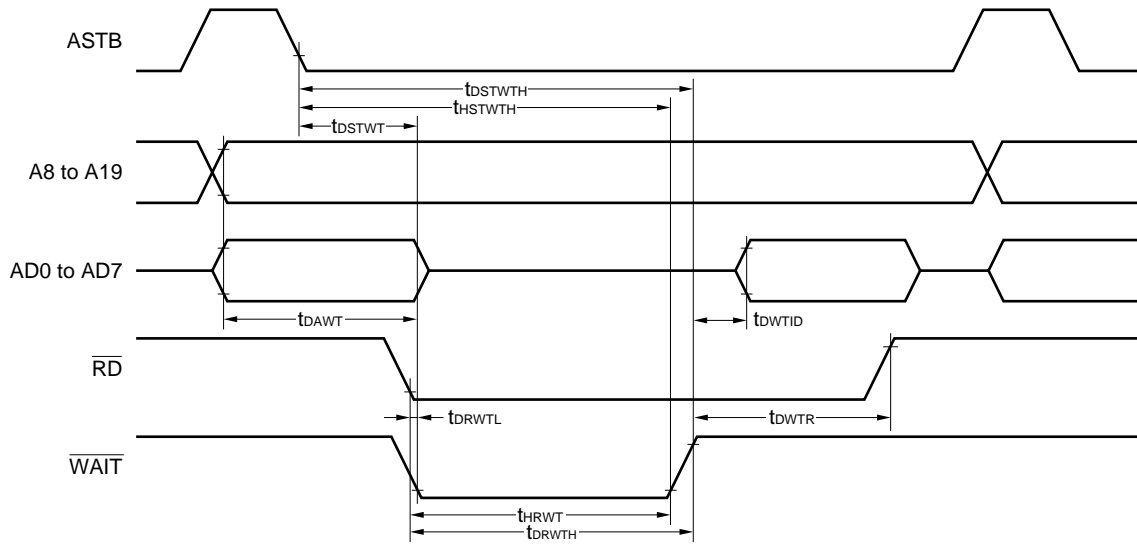

(2) Write operation

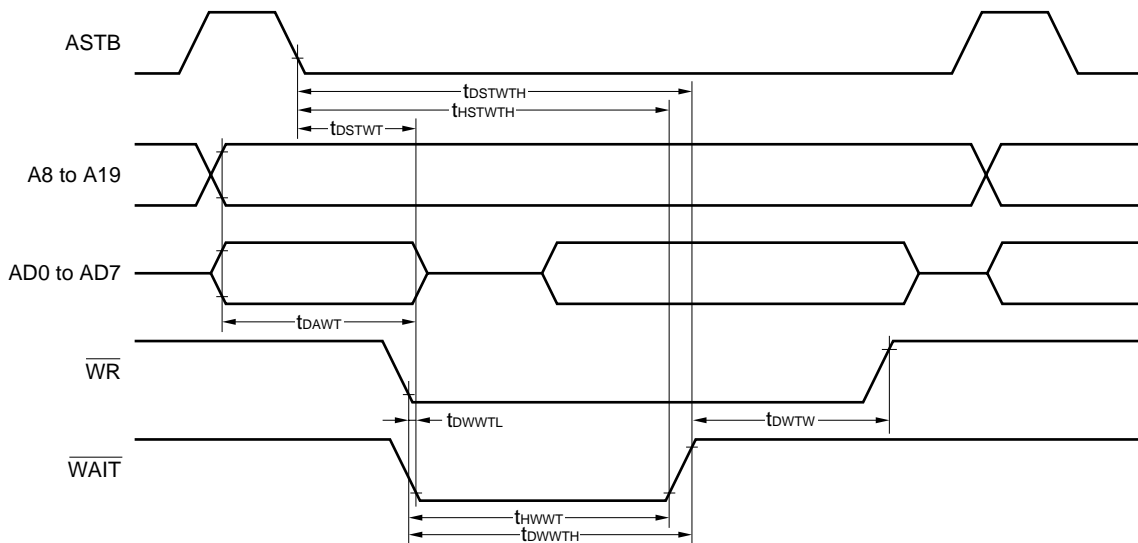



Refresh Timing Waveform

(1) Random read/write cycle

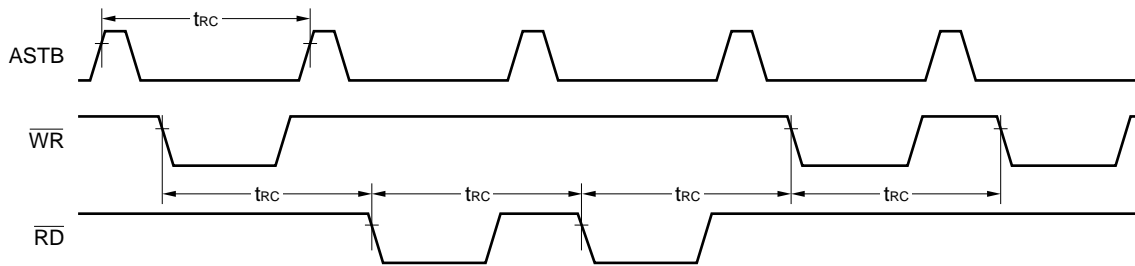

(2) When refresh memory is accessed for a read and write at the same time

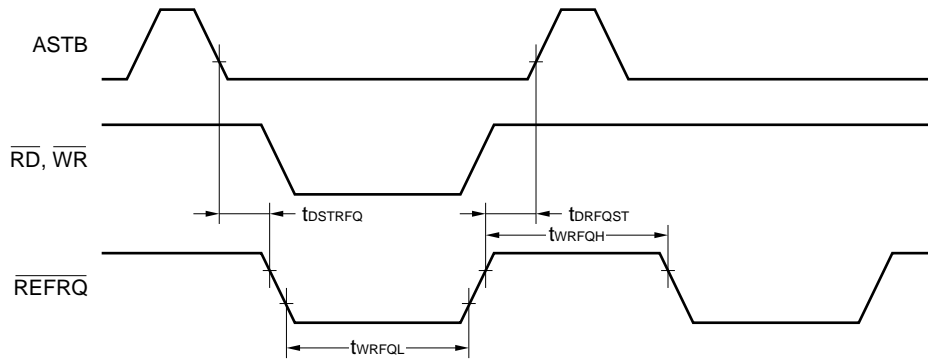

(3) Refresh after a read

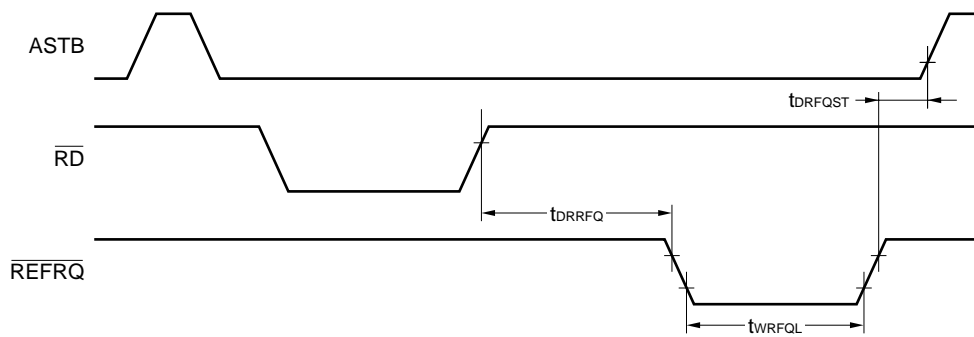

(4) Refresh after a write

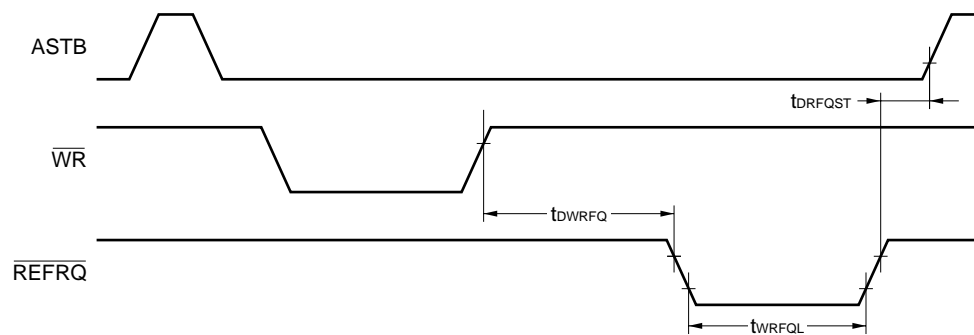

Serial Operation (T<sub>A</sub> = -40 to +85°C, V<sub>DD</sub> = AV<sub>DD</sub> = 3.0 to 5.5 V, V<sub>SS</sub> = AV<sub>SS</sub> = 0 V)

(a) CSI0, CSI3 3-wire serial I/O mode ( $\overline{\text{SCK0}}$ ,  $\overline{\text{SCK3}}$  ... External clock input)

Parameter	Symbol	Conditions	MIN.	MAX.	Unit
$\overline{\text{SCK}}$ cycle time ( $\overline{\text{SCK0}}$ , $\overline{\text{SCK3}}$ )	t <sub>CYSK0</sub> , t <sub>CYSK3</sub>	SO0 and SO3 are CMOS outputs	f <sub>CLK</sub> = f <sub>XX</sub>	8/f <sub>XX</sub>	ns
			Except f <sub>CLK</sub> = f <sub>XX</sub>	4/f <sub>CLK</sub>	ns
$\overline{\text{SCK}}$ low-level width ( $\overline{\text{SCK0}}$ , $\overline{\text{SCK3}}$ )	t <sub>WSKL0</sub> , t <sub>WSKL3</sub>	SO0 and SO3 are CMOS outputs	f <sub>CLK</sub> = f <sub>XX</sub>	4/f <sub>XX</sub> - 40	ns
			Except f <sub>CLK</sub> = f <sub>XX</sub>	2/f <sub>CLK</sub> - 40	ns
$\overline{\text{SCK}}$ high-level width ( $\overline{\text{SCK0}}$ , $\overline{\text{SCK3}}$ )	t <sub>WSKH0</sub> , t <sub>WSKH3</sub>	SO0 and SO3 are CMOS outputs	f <sub>CLK</sub> = f <sub>XX</sub>	4/f <sub>XX</sub> - 40	ns
			Except f <sub>CLK</sub> = f <sub>XX</sub>	2/f <sub>CLK</sub> - 40	ns
SI0, SI3 setup time (to $\overline{\text{SCK0}}$ , $\overline{\text{SCK3}}$ ↑)	t <sub>SSSK0</sub> , t <sub>SSSK3</sub>		80		ns
SI0, SI3 hold time (from $\overline{\text{SCK0}}$ , $\overline{\text{SCK3}}$ ↑)	t <sub>HSSK0</sub> , t <sub>HSSK3</sub>		1/f <sub>CLK</sub> + 80		ns
Delay time from $\overline{\text{SCK0}}$ , $\overline{\text{SCK3}}$ ↓ to output	t <sub>DBSK0</sub> , t <sub>DBSK3</sub>	CMOS output	0	1/f <sub>CLK</sub> + 150	ns
		N-ch open-drain output (R <sub>L</sub> = 1 kΩ)	0	1/f <sub>CLK</sub> + 400	ns
SO0, SO3 output hold time (from $\overline{\text{SCK0}}$ , $\overline{\text{SCK3}}$ ↑)	t <sub>HSBSK0</sub> , t <sub>HSBSK3</sub>	When data is transferred	0.5t <sub>CYSK0</sub> - 40, 0.5t <sub>CYSK3</sub> - 40		ns

- Remarks**
- The values in this table are those when CL = 100 pF.
  - f<sub>XX</sub>: External oscillator frequency (f<sub>XX</sub> = 12.58 MHz or f<sub>XX</sub> = 6.29 MHz)
  - f<sub>CLK</sub>: System clock oscillation frequency (selectable from f<sub>XX</sub>, f<sub>XX</sub>/2, f<sub>XX</sub>/4, and f<sub>XX</sub>/8 by the standby control register (STBC))

(b) CSI0, CSI3 3-wire serial I/O mode ( $\overline{\text{SCK0}}$ ,  $\overline{\text{SCK3}}$  ... Internal clock output)

Parameter	Symbol	Conditions	MIN.	MAX.	Unit
$\overline{\text{SCK}}$ cycle time ( $\overline{\text{SCK0}}$ , $\overline{\text{SCK3}}$ )	t <sub>CYSK0</sub> , t <sub>CYSK3</sub>	SO0 and SO3 are CMOS outputs	Except f <sub>CLK</sub> = f <sub>XX</sub> /8	8/f <sub>XX</sub>	ns
			f <sub>CLK</sub> = f <sub>XX</sub> /8	16/f <sub>XX</sub>	ns
$\overline{\text{SCK}}$ low-level width ( $\overline{\text{SCK0}}$ , $\overline{\text{SCK3}}$ )	t <sub>WSKL0</sub> , t <sub>WSKL3</sub>	SO0 and SO3 are CMOS outputs	Except f <sub>CLK</sub> = f <sub>XX</sub> /8	4/f <sub>XX</sub> - 40	ns
			f <sub>CLK</sub> = f <sub>XX</sub> /8	8/f <sub>XX</sub> - 40	ns
$\overline{\text{SCK}}$ high-level width ( $\overline{\text{SCK0}}$ , $\overline{\text{SCK3}}$ )	t <sub>WSKH0</sub> , t <sub>WSKH3</sub>	SO0 and SO3 are CMOS outputs	Except f <sub>CLK</sub> = f <sub>XX</sub> /8	4/f <sub>XX</sub> - 40	ns
			f <sub>CLK</sub> = f <sub>XX</sub> /8	8/f <sub>XX</sub> - 40	ns
SI0, SI3 setup time (to $\overline{\text{SCK0}}$ , $\overline{\text{SCK3}}$ ↑)	t <sub>SSSK0</sub> , t <sub>SSSK3</sub>		80		ns
SI0, SI3 hold time (from $\overline{\text{SCK0}}$ , $\overline{\text{SCK3}}$ ↑)	t <sub>HSSK0</sub> , t <sub>HSSK3</sub>		80		ns
Delay time from $\overline{\text{SCK0}}$ , $\overline{\text{SCK3}}$ ↓ to output	t <sub>DBSK0</sub> , t <sub>DBSK3</sub>	CMOS output	0	150	ns
		N-ch open-drain output (R <sub>L</sub> = 1 kΩ)	0	400	ns
SO0, SO3 output hold time (from $\overline{\text{SCK0}}$ , $\overline{\text{SCK3}}$ ↑)	t <sub>HSBSK0</sub> , t <sub>HSBSK3</sub>	When data is transferred	0.5t <sub>CYSK0</sub> - 40, 0.5t <sub>CYSK3</sub> - 40		ns

- Remarks**
- The values in this table are those when CL = 100 pF.
  - f<sub>XX</sub>: External oscillator frequency (f<sub>XX</sub> = 12.58 MHz or f<sub>XX</sub> = 6.29 MHz)
  - f<sub>CLK</sub>: System clock oscillation frequency (selectable from f<sub>XX</sub>, f<sub>XX</sub>/2, f<sub>XX</sub>/4, and f<sub>XX</sub>/8 by the standby control register (STBC))

Serial Operation ( $T_A = -40$  to  $+85^\circ\text{C}$ ,  $V_{DD} = AV_{DD} = 3.0$  to  $5.5$  V,  $V_{SS} = AV_{SS} = 0$  V)

(c) UART0, UART3 (Asynchronous serial interface mode)

Parameter	Symbol	Conditions	MIN.	TYP.	MAX.	Unit
ASCK0, ASCK2 cycle time	$t_{CYASK}$	$4.0 \leq V_{DD} \leq 5.5$ V	160			ns
			320			ns
ASCK0, ASCK2 low-level width	$t_{WASKL}$	$4.0 \leq V_{DD} \leq 5.5$ V	65			ns
			120			ns
ASCK0, ASCK2 high-level width	$t_{WASKH}$	$4.0 \leq V_{DD} \leq 5.5$ V	65			ns
			120			ns

Serial Operation ( $T_A = -40$  to  $+85^\circ\text{C}$ ,  $V_{DD} = AV_{DD} = 3.0$  to  $5.5$  V,  $V_{SS} = AV_{SS} = 0$  V)

(d) IOE1, IOE2 3-wire serial I/O mode ( $\overline{\text{SCK1}}$ ,  $\overline{\text{SCK2}}$  ... External clock input)

Parameter	Symbol	Conditions	MIN.	MAX.	Unit
$\overline{\text{SCK}}$ cycle time ( $\overline{\text{SCK1}}$ , $\overline{\text{SCK2}}$ )	$t_{\text{CYSK1}}$	$4.0 \leq V_{DD} \leq 5.5$ V	640		ns
	$t_{\text{CYSK2}}$		1280		ns
$\overline{\text{SCK}}$ low-level width ( $\overline{\text{SCK1}}$ , $\overline{\text{SCK2}}$ )	$t_{\text{WSKL1}}$	$4.0 \leq V_{DD} \leq 5.5$ V	280		ns
	$t_{\text{WSKL2}}$		600		ns
$\overline{\text{SCK}}$ high-level width ( $\overline{\text{SCK1}}$ , $\overline{\text{SCK2}}$ )	$t_{\text{WSKH1}}$	$4.0 \leq V_{DD} \leq 5.5$ V	280		ns
	$t_{\text{WSKH2}}$		600		ns
SI1, SI2 setup time (to $\overline{\text{SCK1}}$ , $\overline{\text{SCK2}}\uparrow$ )	$t_{\text{SSSK1}}$ , $t_{\text{SSSK2}}$		40		ns
SI1, SI2 hold time (from $\overline{\text{SCK1}}$ , $\overline{\text{SCK2}}\uparrow$ )	$t_{\text{HSSK1}}$ , $t_{\text{HSSK2}}$		40		ns
Delay time from $\overline{\text{SCK1}}$ , $\overline{\text{SCK2}}\downarrow$ to output	$t_{\text{DSOSK1}}$ , $t_{\text{DSOSK2}}$		0	50	ns
SO1, SO2 output hold time (from $\overline{\text{SCK1}}$ , $\overline{\text{SCK2}}\uparrow$ )	$t_{\text{HSOSK1}}$ , $t_{\text{HSOSK2}}$	When data is transferred	$0.5t_{\text{CYSK1}} - 40$ , $0.5t_{\text{CYSK2}} - 40$		ns

- Remarks 1.** The values in this table are those when  $CL = 100$  pF.  
**2.** T: Selected serial clock cycle. The minimum value is  $8/f_{xx}$ .

(e) IOE1, IOE2 3-wire serial I/O mode ( $\overline{\text{SCK1}}$ ,  $\overline{\text{SCK2}}$  ... Internal clock output)

Parameter	Symbol	Conditions	MIN.	MAX.	Unit
$\overline{\text{SCK}}$ cycle time ( $\overline{\text{SCK1}}$ , $\overline{\text{SCK2}}$ )	$t_{\text{CYSK1}}$ $t_{\text{CYSK2}}$		T		ns
$\overline{\text{SCK}}$ low-level width ( $\overline{\text{SCK1}}$ , $\overline{\text{SCK2}}$ )	$t_{\text{WSKL1}}$ , $t_{\text{WSKL2}}$		$0.5T - 40$		ns
$\overline{\text{SCK}}$ high-level width ( $\overline{\text{SCK1}}$ , $\overline{\text{SCK2}}$ )	$t_{\text{WSKH1}}$ , $t_{\text{WSKH2}}$		$0.5T - 40$		ns
SI1, SI2 setup time (to $\overline{\text{SCK1}}$ , $\overline{\text{SCK2}}\uparrow$ )	$t_{\text{SSSK1}}$ , $t_{\text{SSSK2}}$		40		ns
SI1, SI2 hold time (from $\overline{\text{SCK1}}$ , $\overline{\text{SCK2}}\uparrow$ )	$t_{\text{HSSK1}}$ , $t_{\text{HSSK2}}$		40		ns
Delay time from $\overline{\text{SCK1}}$ , $\overline{\text{SCK2}}\downarrow$ to output	$t_{\text{DSOSK1}}$ , $t_{\text{DSOSK2}}$		0	50	ns
SO1, SO2 output hold time (from $\overline{\text{SCK1}}$ , $\overline{\text{SCK2}}\uparrow$ )	$t_{\text{HSOSK1}}$ , $t_{\text{HSOSK2}}$	When data is transferred	$0.5t_{\text{CYSK1}} - 40$ , $0.5t_{\text{CYSK2}} - 40$		ns

- Remarks 1.** The values in this table are those when  $CL = 100$  pF.  
**2.** T: Selected serial clock cycle. The minimum value is  $8/f_{xx}$ .

**Other Operations (T<sub>A</sub> = -40 to +85°C, V<sub>DD</sub> = AV<sub>DD</sub> = 3.0 to 5.5 V, V<sub>SS</sub> = AV<sub>SS</sub> = 0 V)**

Parameter	Symbol	Conditions	MIN.	TYP.	MAX.	Unit
NMI high-/low-level width	t <sub>WNIL</sub> t <sub>WNIH</sub>		10			μs
INTP0 high-/low-level width	t <sub>WIT0L</sub> t <sub>WIT0H</sub>		4t <sub>CYAMP</sub>			s
INTP1 to INTP3, CI high-/low-level width	t <sub>WIT1L</sub> t <sub>WIT1H</sub>		4t <sub>CYCPU</sub>			s
INTP4, INTP5 high-/low-level width	t <sub>WIT2L</sub> t <sub>WIT2H</sub>		10			μs
RESET high-/low-level width <sup>Note</sup>	t <sub>WRSL</sub> t <sub>WRSH</sub>		10			μs

**Note** When the power is turned on or when STOP mode is released by reset, secure the oscillation stabilization wait time while the RESET is at a low-level width.

When the power is applied, be sure to activate V<sub>DD</sub> in the RESET = low-level state.

**Remark** t<sub>CYAMP</sub>: Sampling clock set by software

t<sub>CYCPU</sub>: CPU clock set by software in the CPU

**Clock Output Operation (T<sub>A</sub> = -40 to +85°C, V<sub>DD</sub> = AV<sub>DD</sub> = 3.0 to 5.5 V, V<sub>SS</sub> = AV<sub>SS</sub> = 0 V)**

Parameter	Symbol	Conditions	MIN.	TYP.	MAX.	Unit
CLKOUT cycle time	t <sub>CYCL</sub>	nT	79		32000	ns
CLKOUT low-level width	t <sub>CLL</sub>	4.5 ≤ V <sub>DD</sub> ≤ 5.5 V	0.5T - 10			ns
			0.5T - 20			ns
CLKOUT high-level width	t <sub>CLH</sub>	4.5 ≤ V <sub>DD</sub> ≤ 5.5 V	0.5T - 10			ns
			0.5T - 20			ns
CLKOUT rise time	t <sub>CLR</sub>	4.5 ≤ V <sub>DD</sub> ≤ 5.5 V			10	ns
		3.0 ≤ V <sub>DD</sub> ≤ 4.5 V			20	ns
CLKOUT fall time	t <sub>CLF</sub>	4.5 ≤ V <sub>DD</sub> ≤ 5.5 V			10	ns
		3.0 ≤ V <sub>DD</sub> ≤ 4.5 V			20	ns

**Remark** n: Division ratio of clock output frequency, T: t<sub>CYK</sub> = 1/f<sub>CLK</sub> (system clock cycle time)

**IEBus Controller Characteristics (T<sub>A</sub> = -40 to +85°C, V<sub>DD</sub> = AV<sub>DD</sub> = 4.5 to 5.5 V, V<sub>SS</sub> = AV<sub>SS</sub> = 0 V)**

Parameter	Symbol	Conditions	MIN.	TYP.	MAX.	Unit
IEBus system clock frequency	f <sub>s</sub>	Mode 1		6.29		MHz

**Remark** Although the system clock frequency in the IEBus specifications is 6.0 MHz, in the μPD78F4938A, operation at 6.29 MHz is also guaranteed. Note, however, that operation at 6.0 MHz and 6.29 MHz cannot be used together.

**A/D Converter Characteristics (T<sub>A</sub> = -40 to +85°C, V<sub>DD</sub> = AV<sub>DD</sub> = AV<sub>REF1</sub> = 3.0 to 5.5 V, V<sub>SS</sub> = AV<sub>SS</sub> = 0 V)**

Parameter	Symbol	Conditions	MIN.	TYP.	MAX.	Unit	
Resolution			8			bit	
Overall error <sup>Note 1</sup>		IEAD = 00H	6.29 MHz ≤ f <sub>xx</sub> ≤ 12.58 MHz and other than FR = 1			±0.6	%FSR <sup>Note 2</sup>
			6.29 MHz ≤ f <sub>xx</sub> ≤ 12.58 MHz and FR = 1			±1.5	%FSR <sup>Note 2</sup>
		IEAD = 01H	4.5 ≤ V <sub>DD</sub> ≤ 5.5 V		±1	±2.2	%FSR <sup>Note 2</sup>
			3.0 ≤ V <sub>DD</sub> < 5.5 V		±1.4	±2.6	%FSR <sup>Note 2</sup>
Quantization error					±1/2	LSB	
Conversion time	t <sub>CONV</sub>	FR = 1: 120t <sub>CYK</sub>	9.5		480	μs	
		FR = 0: 240t <sub>CYK</sub>	19.1		960	μs	
Sampling time	t <sub>SAMP</sub>	FR = 1: 18t <sub>CYK</sub>	1.4		72	μs	
		FR = 0: 36t <sub>CYK</sub>	2.9		144	μs	
Analog input voltage	V <sub>IAN</sub>		AV <sub>SS</sub>		AV <sub>REF1</sub>	V	
Analog input impedance	R <sub>AN</sub>			1000		MΩ	
Reference voltage	AV <sub>REF1</sub>		3.0		AV <sub>DD</sub>	V	
AV <sub>REF1</sub> resistor	R <sub>AVREF1</sub>		3.0	10		kΩ	
AV <sub>REF1</sub> current	AI <sub>REF1</sub>			0.5	1.5	mA	
AV <sub>DD</sub> current	AI <sub>DD1</sub>			2.0	5.0	mA	
	AI <sub>DD2</sub>				20	mA	

- Notes**
1. Excludes quantization error (±1/2 LSB).
  2. It is indicated as a ratio (%FSR) to the full-scale value.

**Caution** The analog input pins of the μPD78F4938A function alternately as the port 7 pins (I/O port pins). However when using the A/D converter, it is necessary to set all the pins of port 7 to input mode in order to prevent data from being inverted by the output port operation, thus degrading the A/D conversion accuracy. At this time, pins cannot be used as output ports even though they are not used as A/D analog input port.

**Serial Operation (CSI, CSI3)**

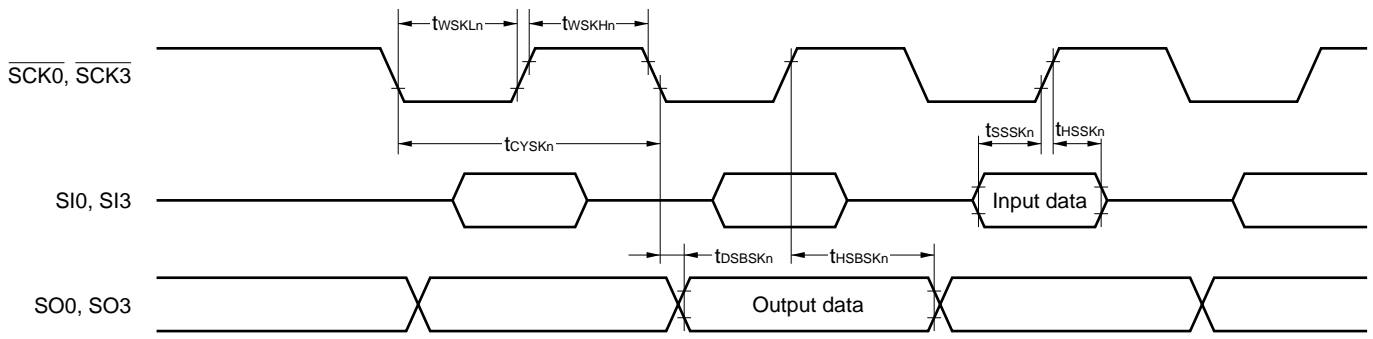

$n = 0, 3$

**Serial Operation (IOE1, IOE2)**

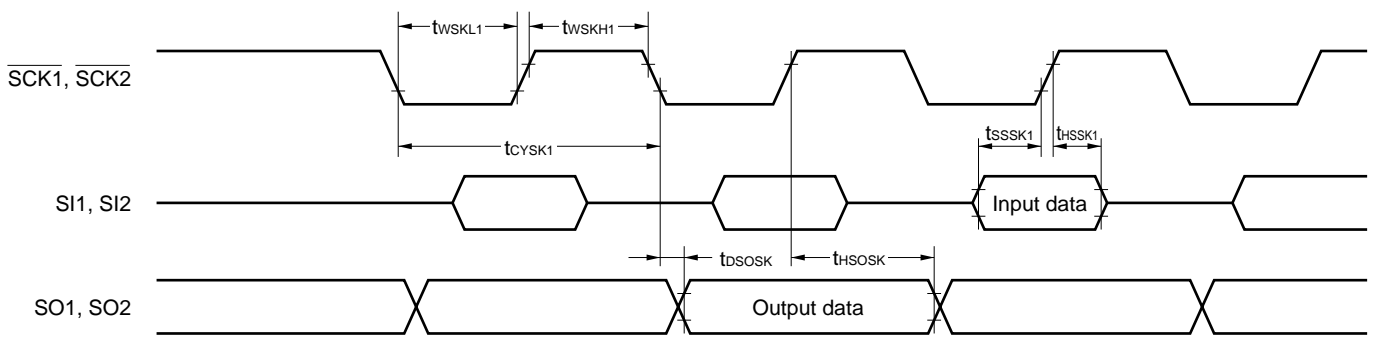

**Serial Operation (UART0, UART2)**

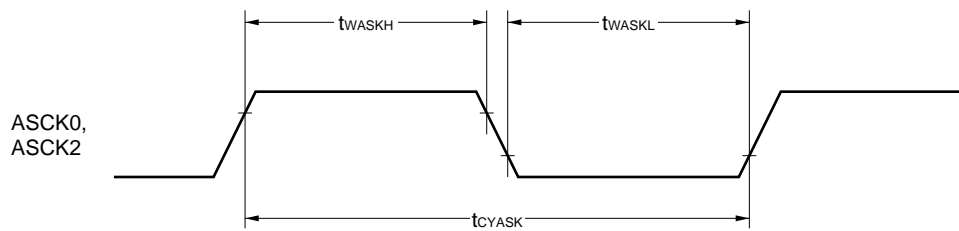

**Clock Output Timing**

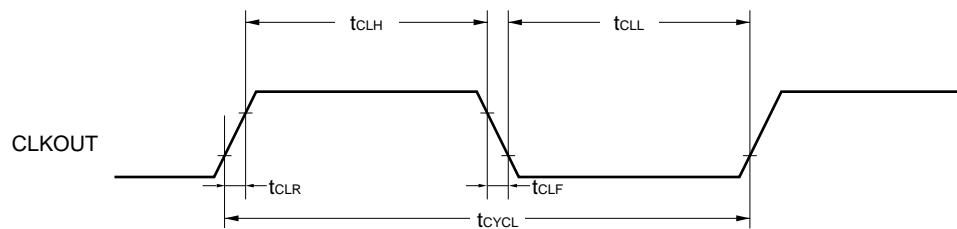

**Interrupt Request Input Timing**

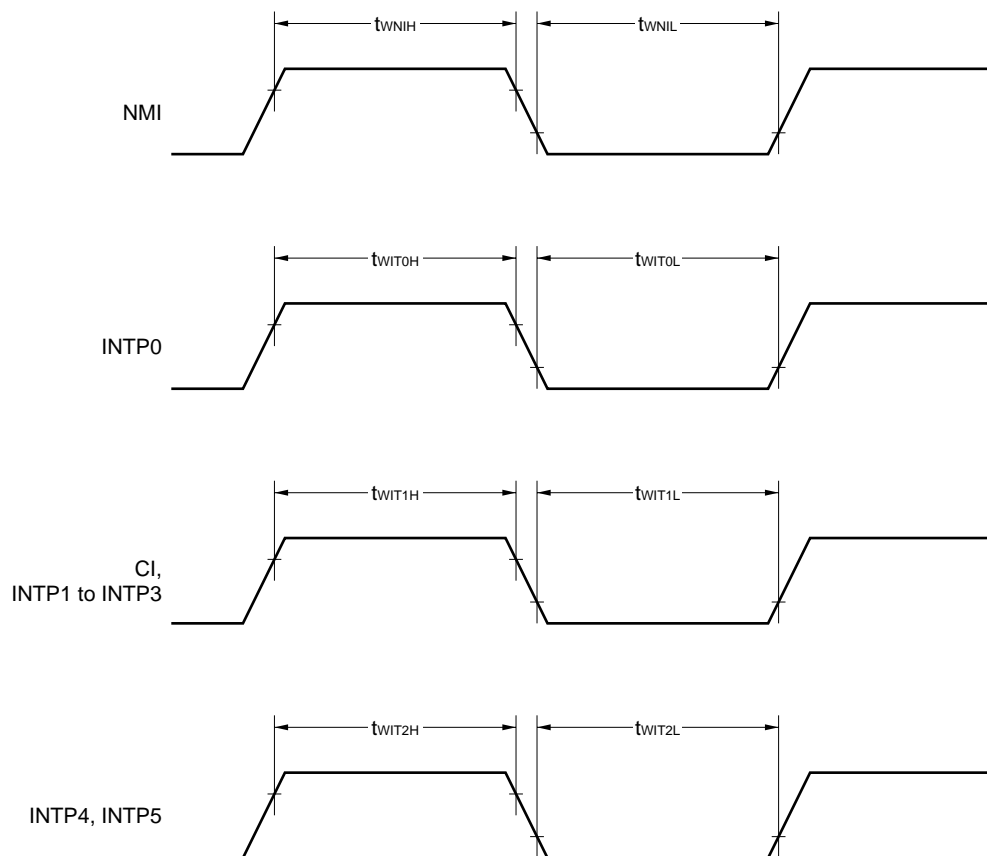

**Reset Input Timing**

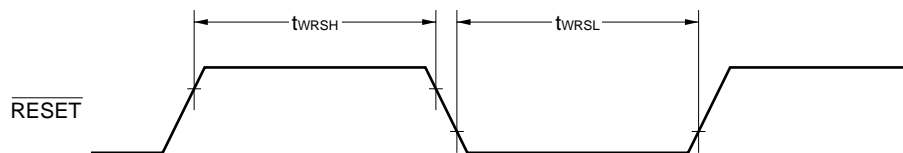



Data Retention Characteristics

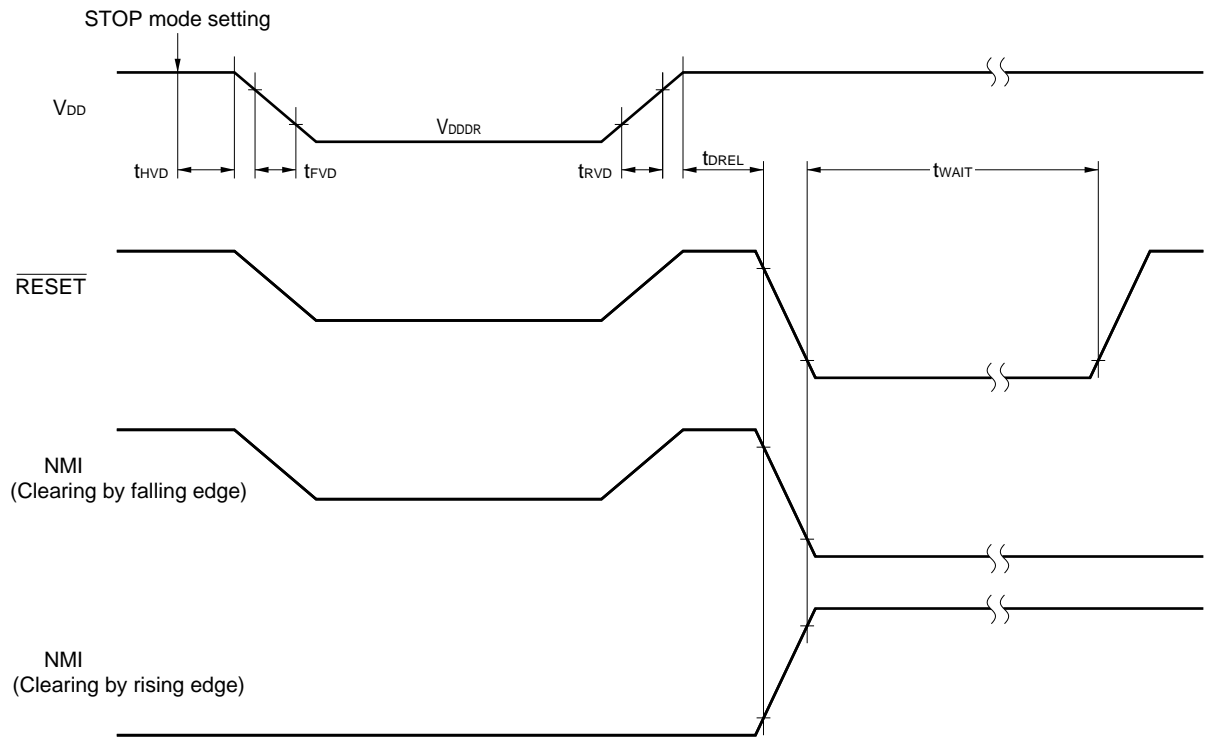

8. PACKAGE DRAWING

100PIN PLASTIC QFP (14x20)

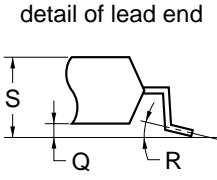
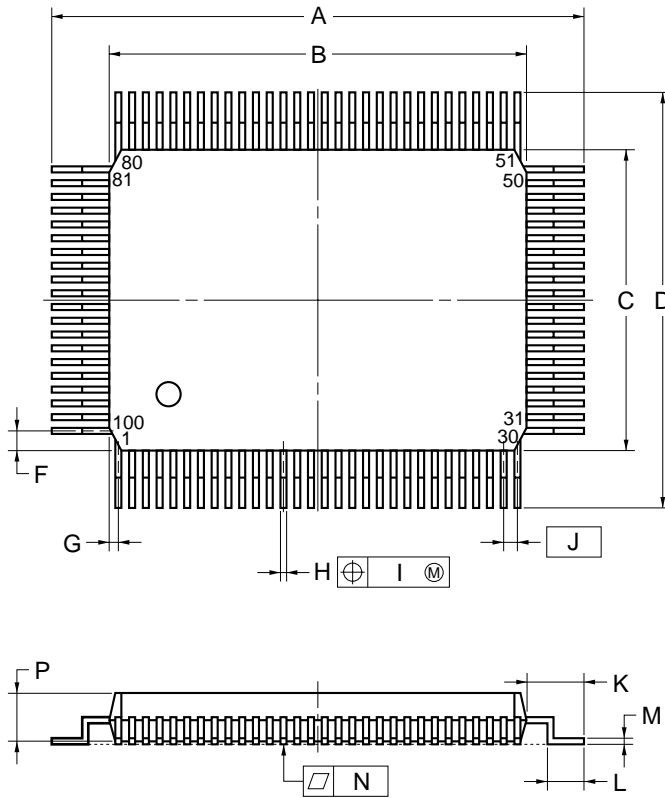

NOTE

Each lead centerline is located within 0.15 mm (0.006 inch) of its true position (T.P.) at maximum material condition.

ITEM	MILLIMETERS	INCHES
A	23.6±0.4	0.929±0.016
B	20.0±0.2	0.795 <sup>+0.009</sup> <sub>-0.008</sub>
C	14.0±0.2	0.551 <sup>+0.009</sup> <sub>-0.008</sub>
D	17.6±0.4	0.693±0.016
F	0.8	0.031
G	0.6	0.024
H	0.30±0.10	0.012 <sup>+0.004</sup> <sub>-0.005</sub>
I	0.15	0.006
J	0.65 (T.P.)	0.026 (T.P.)
K	1.8±0.2	0.071 <sup>+0.008</sup> <sub>-0.009</sub>
L	0.8±0.2	0.031 <sup>+0.009</sup> <sub>-0.008</sub>
M	0.15 <sup>+0.10</sup> <sub>-0.05</sub>	0.006 <sup>+0.004</sup> <sub>-0.003</sub>
N	0.10	0.004
P	2.7±0.1	0.106 <sup>+0.005</sup> <sub>-0.004</sub>
Q	0.1±0.1	0.004±0.004
R	5°±5°	5°±5°
S	3.0 MAX.	0.119 MAX.

P100GF-65-3BA1-3

**Remark** The external dimensions and material of the ES version are the same as those of the mass-produced version.

**9. RECOMMENDED SOLDERING CONDITIONS**

The μPD78F4938A should be soldered and mounted under the following recommended conditions.

For details of the recommended soldering conditions, refer to the document **Semiconductor Device Mounting Technology Manual (C10535E)**.

For soldering methods and conditions other than those recommended below, contact an NEC sales representative.

**Table 9-1. Surface Mounting Type Soldering Conditions**

**μPD78F4938AGF-3BA: 100-pin plastic QFP (14 × 20)**

Soldering Method	Soldering Conditions	Recommended Condition Symbol
Infrared reflow	Package peak temperature: 235°C, Time: 30 seconds max. (at 210°C or higher), Count: two times or less, Exposure limit: 7 days <sup>Note</sup> (after that, prebake at 125°C for 20 hours)	IR35-207-2
VPS	Package peak temperature: 215°C, Time: 40 seconds max. (at 200°C or higher), Count: two times or less, Exposure limit: 7 days <sup>Note</sup> (after that, prebake at 125°C for 20 hours)	VP15-207-2
Wave soldering	Solder bath temperature: 260°C max., Time: 10 seconds max., Count: once, Preheating temperature: 120°C max. (package surface temperature), Exposure limit: 7 days <sup>Note</sup> (after that, prebake at 125°C for 20 hours)	WS60-207-1
Partial heating	Pin temperature: 300°C max., Time: 3 seconds max. (per pin row)	—

**Note** After opening the dry pack, store it at 25°C or less and 65% RH or less for the allowable storage period.

## APPENDIX A. DEVELOPMENT TOOLS

The following development tools are available for system development using the μPD78F4938A.

Also refer to **(5) Cautions on using development tools.**

### (1) Language processing software

RA78K4	Assembler package common to 78K/IV Series
CC78K4	C compiler package common to 78K/IV Series
DF784937	Device file for μPD784938A Subseries
CC78K4-L	C compiler library source file common to 78K/IV Series

### (2) Flash memory writing tools

Flashpro III (PG-FP3)	Flash programmer for microcontroller with on-chip flash memory
FA-100GF	Flash memory writing adapter for 100-pin plastic QFP (GF-3BA type). Wiring must be performed according to the product used.

### (3) Debugging tools

- **When IE-78K4-NS in-circuit emulator is used**

IE-78K4-NS	In-circuit emulator common to 78K/IV Series
IE-70000-MC-PS-B	Power supply unit for IE-78K4-NS
IE-70000-98-IF-C	Interface adapter used when PC-9800 series (except notebook type) is used as host machine
IE-70000-CD-IF-C	PC card and cable used when PC-9800 series notebook type PC is used as host machine
IE-70000-PC-IF-C	Interface adapter used when IBM PC/AT™ or compatible is used as host machine
IE-784937-NS-EM1	Emulation board to emulate μPD784938A Subseries
NP-100GF	Emulation probe for 100-pin plastic QFP (GF-3BA type)
EV-9200GF-100	Socket to be mounted on a target system board made for 100-pin plastic QFP (GF-3BA type)
ID78K4-NS	Integrated debugger for IE-78K4-NS
SM78K4	System simulator common to 78K/IV Series
DF784937	Device file for μPD784938A Subseries

- When IE-784000-R in-circuit emulator is used

IE-784000-R	In-circuit emulator common to 78K/IV Series
IE-70000-98-IF-B IE-70000-98-IF-C	Interface adapter used when PC-9800 series (except notebook type) is used as host machine
IE-70000-98N-IF	Interface adapter and cable used when PC-9800 series notebook type PC is used as host machine
IE-70000-PC-IF-B IE-70000-PC-IF-C	Interface adapter used when IBM PC/AT or compatible is used as host machine
IE-78000-R-SV3	Interface adapter and cable used when EWS is used as host machine
IE-784937-NS-EM1	Emulation board to emulate $\mu$ PD784938A Subseries
IE-784000-R-EM	Emulation board common to 78K/IV Series
IE-78K4-R-EX2	Emulation probe conversion board necessary when using IE-784937-NS-EM1 on IE-784000-R. Not necessary when using IE-784937-R-EM1
EP-78064GF-R	Emulation probe for 100-pin plastic QFP (GF-3BA type)
EV-9200GF-100	Socket to be mounted on a target system board made for 100-pin plastic QFP (GF-3BA type)
ID78K4	Integrated debugger for IE-784000-R
SM78K4	System simulator common to 78K/IV Series
DF784937	Device file for $\mu$ PD784938A Subseries

#### (4) Real-time OS

RX78K/IV	Real-time OS for 78K/IV Series
MX78K4	OS for 78K/IV Series

**(5) Cautions on using development tools**

- The ID78K4-NS, ID78K4, and SM78K4 are used in combination with the DF784937.
- The CC78K4 and RX78K/IV are used in combination with the RA78K4 or DF784937.
- The Flashpro III, FA-100GF, and NP-100GF are products made by Naito Densai Machida Mfg. Co, Ltd (TEL +81-44-822-3813).
- The host machine and OS suitable for each software are as follows:

Host Machine [OS] Software	PC	EWS
	PC-9800 series [Windows] IBM PC/AT and compatibles [Japanese/English Windows]	HP9000 series 700™ [HP-UX™] SPARCstation™ [SunOS™, Solaris™] NEWS™ (RISC) [NEWS-OS™]
RA78K4	√ <b>Note</b>	√
CC78K4	√ <b>Note</b>	√
ID78K4-NS	√	—
ID78K4	√	√
SM78K4	√	—
RX78K/IV	√ <b>Note</b>	√
MX78K4	√ <b>Note</b>	√

**Note** DOS-based software

**APPENDIX B. RELATED DOCUMENTS**

The related documents indicated in this publication may include preliminary versions. However, preliminary versions are not marked as such.

• **Documents related to devices**

Document Name	Document No.
μPD784935A, 784936A, 784937A, 784938A Data Sheet	Under preparation
μPD78F4938A Data Sheet	This document
μPD784938 Subseries User's Manual Hardware	U13987E
78K/IV Series User's Manual Instructions	U10905E
78K/IV Series Application Note Software Basics	U10095E

• **Documents related to development tools (user's manuals)**

Document Name		Document No.
RA78K4 Assembler Package	Language	U11162E
	Operation	U11334E
	Structured Assembler Preprocessor	U11743E
CC78K4 C Compiler	Language	U11571E
	Operation	U11572E
PG-FP3 Flash Memory Programmer		U13502E
IE-78K4-NS		U13556E
IE-784000-R		U12903E
IE-784937-R-EM1		To be prepared
IE-784937-NS-EM1		To be prepared
EP-78064		EEU-1469
SM78K4 System Simulator Windows Based	Reference	U10093E
SM78K Series System Simulator	External Part User Open Interface Specifications	U10092E
ID78K4 Integrated Debugger Windows Based	Reference	U10440E
ID78K4-NS Integrated Debugger Windows Based	Reference	U12796E
Project Manager Ver. 3.12 or Later Windows Based		U14610E

**Caution** The related documents listed above are subject to change without notice. Be sure to use the latest version of each document for designing.

• Documents related to embedded software (user's manuals)

Document Name		Document No.
78K/IV Series Real-Time OS	Fundamental	U10603E
	Installation	U10604E

• Other documents

Document Name	Document No.
SEMICONDUCTOR SELECTION GUIDE Products & Packages (CD-ROM)	X13769X
Semiconductor Device Mounting Technology Manual	C10535E
Quality Grades on NEC Semiconductor Devices	C11531E
NEC Semiconductor Device Reliability/Quality Control System	U10983E
Guide to Prevent Damage for Semiconductor Devices by Electrostatic Discharge (ESD)	C11892E

**Caution** The related documents listed above are subject to change without notice. Be sure to use the latest version of each document for designing.



[MEMO]

**NOTES FOR CMOS DEVICES****① PRECAUTION AGAINST ESD FOR SEMICONDUCTORS**

Note:

Strong electric field, when exposed to a MOS device, can cause destruction of the gate oxide and ultimately degrade the device operation. Steps must be taken to stop generation of static electricity as much as possible, and quickly dissipate it once, when it has occurred. Environmental control must be adequate. When it is dry, humidifier should be used. It is recommended to avoid using insulators that easily build static electricity. Semiconductor devices must be stored and transported in an anti-static container, static shielding bag or conductive material. All test and measurement tools including work bench and floor should be grounded. The operator should be grounded using wrist strap. Semiconductor devices must not be touched with bare hands. Similar precautions need to be taken for PW boards with semiconductor devices on it.

**② HANDLING OF UNUSED INPUT PINS FOR CMOS**

Note:

No connection for CMOS device inputs can be cause of malfunction. If no connection is provided to the input pins, it is possible that an internal input level may be generated due to noise, etc., hence causing malfunction. CMOS devices behave differently than Bipolar or NMOS devices. Input levels of CMOS devices must be fixed high or low by using a pull-up or pull-down circuitry. Each unused pin should be connected to  $V_{DD}$  or GND with a resistor, if it is considered to have a possibility of being an output pin. All handling related to the unused pins must be judged device by device and related specifications governing the devices.

**③ STATUS BEFORE INITIALIZATION OF MOS DEVICES**

Note:

Power-on does not necessarily define initial status of MOS device. Production process of MOS does not define the initial operation status of the device. Immediately after the power source is turned ON, the devices with reset function have not yet been initialized. Hence, power-on does not guarantee out-pin levels, I/O settings or contents of registers. Device is not initialized until the reset signal is received. Reset operation must be executed immediately after power-on for devices having reset function.

**EEPROM, FIP, and IEBus are trademarks of NEC Corporation.  
Windows is either a registered trademark or a trademark of Microsoft Corporation in the United States and/or other countries.**

**PC/AT is a trademark of International Business Machines Corporation.**

**HP9000 series 700 and HP-UX are trademarks of Hewlett-Packard Company.**

**SPARCstation is a trademark of SPARC International, Inc.**

**Solaris and SunOS are trademarks of Sun Microsystems, Inc.**

**NEWS and NEWS-OS are trademarks of Sony Corporation.**

## Regional Information

Some information contained in this document may vary from country to country. Before using any NEC product in your application, please contact the NEC office in your country to obtain a list of authorized representatives and distributors. They will verify:

- Device availability
- Ordering information
- Product release schedule
- Availability of related technical literature
- Development environment specifications (for example, specifications for third-party tools and components, host computers, power plugs, AC supply voltages, and so forth)
- Network requirements

In addition, trademarks, registered trademarks, export restrictions, and other legal issues may also vary from country to country.

### **NEC Electronics Inc. (U.S.)**

Santa Clara, California  
Tel: 408-588-6000  
800-366-9782  
Fax: 408-588-6130  
800-729-9288

### **NEC Electronics (Germany) GmbH**

Duesseldorf, Germany  
Tel: 0211-65 03 02  
Fax: 0211-65 03 490

### **NEC Electronics (UK) Ltd.**

Milton Keynes, UK  
Tel: 01908-691-133  
Fax: 01908-670-290

### **NEC Electronics Italiana s.r.l.**

Milano, Italy  
Tel: 02-66 75 41  
Fax: 02-66 75 42 99

### **NEC Electronics (Germany) GmbH**

Benelux Office  
Eindhoven, The Netherlands  
Tel: 040-2445845  
Fax: 040-2444580

### **NEC Electronics (France) S.A.**

Velizy-Villacoublay, France  
Tel: 01-3067-5800  
Fax: 01-3067-5899

### **NEC Electronics (France) S.A.**

Madrid Office  
Madrid, Spain  
Tel: 091-504-2787  
Fax: 091-504-2860

### **NEC Electronics (Germany) GmbH**

Scandinavia Office  
Taeby, Sweden  
Tel: 08-63 80 820  
Fax: 08-63 80 388

### **NEC Electronics Hong Kong Ltd.**

Hong Kong  
Tel: 2886-9318  
Fax: 2886-9022/9044

### **NEC Electronics Hong Kong Ltd.**

Seoul Branch  
Seoul, Korea  
Tel: 02-528-0303  
Fax: 02-528-4411

### **NEC Electronics Singapore Pte. Ltd.**

Novena Square, Singapore  
Tel: 253-8311  
Fax: 250-3583

### **NEC Electronics Taiwan Ltd.**

Taipei, Taiwan  
Tel: 02-2719-2377  
Fax: 02-2719-5951

### **NEC do Brasil S.A.**

Electron Devices Division  
Guarulhos-SP, Brasil  
Tel: 11-6462-6810  
Fax: 11-6462-6829

• **The information in this document is current as of December, 2000. The information is subject to change without notice. For actual design-in, refer to the latest publications of NEC's data sheets or data books, etc., for the most up-to-date specifications of NEC semiconductor products. Not all products and/or types are available in every country. Please check with an NEC sales representative for availability and additional information.**

- No part of this document may be copied or reproduced in any form or by any means without prior written consent of NEC. NEC assumes no responsibility for any errors that may appear in this document.
- NEC does not assume any liability for infringement of patents, copyrights or other intellectual property rights of third parties by or arising from the use of NEC semiconductor products listed in this document or any other liability arising from the use of such products. No license, express, implied or otherwise, is granted under any patents, copyrights or other intellectual property rights of NEC or others.
- Descriptions of circuits, software and other related information in this document are provided for illustrative purposes in semiconductor product operation and application examples. The incorporation of these circuits, software and information in the design of customer's equipment shall be done under the full responsibility of customer. NEC assumes no responsibility for any losses incurred by customers or third parties arising from the use of these circuits, software and information.
- While NEC endeavours to enhance the quality, reliability and safety of NEC semiconductor products, customers agree and acknowledge that the possibility of defects thereof cannot be eliminated entirely. To minimize risks of damage to property or injury (including death) to persons arising from defects in NEC semiconductor products, customers must incorporate sufficient safety measures in their design, such as redundancy, fire-containment, and anti-failure features.
- NEC semiconductor products are classified into the following three quality grades:  
"Standard", "Special" and "Specific". The "Specific" quality grade applies only to semiconductor products developed based on a customer-designated "quality assurance program" for a specific application. The recommended applications of a semiconductor product depend on its quality grade, as indicated below. Customers must check the quality grade of each semiconductor product before using it in a particular application.

"Standard": Computers, office equipment, communications equipment, test and measurement equipment, audio and visual equipment, home electronic appliances, machine tools, personal electronic equipment and industrial robots

"Special": Transportation equipment (automobiles, trains, ships, etc.), traffic control systems, anti-disaster systems, anti-crime systems, safety equipment and medical equipment (not specifically designed for life support)

"Specific": Aircraft, aerospace equipment, submersible repeaters, nuclear reactor control systems, life support systems and medical equipment for life support, etc.

The quality grade of NEC semiconductor products is "Standard" unless otherwise expressly specified in NEC's data sheets or data books, etc. If customers wish to use NEC semiconductor products in applications not intended by NEC, they must contact an NEC sales representative in advance to determine NEC's willingness to support a given application.

(Note)

(1) "NEC" as used in this statement means NEC Corporation and also includes its majority-owned subsidiaries.

(2) "NEC semiconductor products" means any semiconductor product developed or manufactured by or for NEC (as defined above).