



MOS INTEGRATED CIRCUIT

μ PD8862

(2700 + 2700) PIXELS \times 3 COLOR CCD LINEAR IMAGE SENSOR

DESCRIPTION

The μ PD8862 is a color CCD (Charge Coupled Device) linear image sensor which changes optical images to electrical signal and has the function of color separation.

The μ PD8862 has 3 rows of (2700 + 2700) staggered pixels, and each row has a dual-sided readout-type charge transfer register. And it has reset feed-through level clamp circuits and voltage amplifiers. Therefore, it is suitable for 600 dpi/A4 color image scanners, color facsimiles and so on.

FEATURES

- Valid photocell : (2700 + 2700) staggered pixels \times 3
- Photocell pitch : 5.25 μ m
- Line spacing : 63 μ m (12 lines) Red line - Green line, Green line - Blue line
10.5 μ m (2 lines) Odd line - Even line (for each color)
- Color filter : Primary colors (red, green and blue), pigment filter (with light resistance 10^7 lx \cdot hour)
- Resolution : 24 dot/mm A4 (210 \times 297 mm) size (shorter side)
600 dpi US letter (8.5" \times 11") size (shorter side)
- Drive clock level : CMOS output under 5 V operation
- Data rate : 6 MHz Max.
- Power supply : +12 V
- On-chip circuits : Reset feed-through level clamp circuits
Voltage amplifiers

ORDERING INFORMATION

Part Number	Package
μ PD8862CY	CCD linear image sensor 22-pin plastic DIP (10.16 mm (400))

The information in this document is subject to change without notice. Before using this document, please confirm that this is the latest version.

Not all products and/or types are available in every country. Please check with an NEC Electronics sales representative for availability and additional information.

BLOCK DIAGRAM

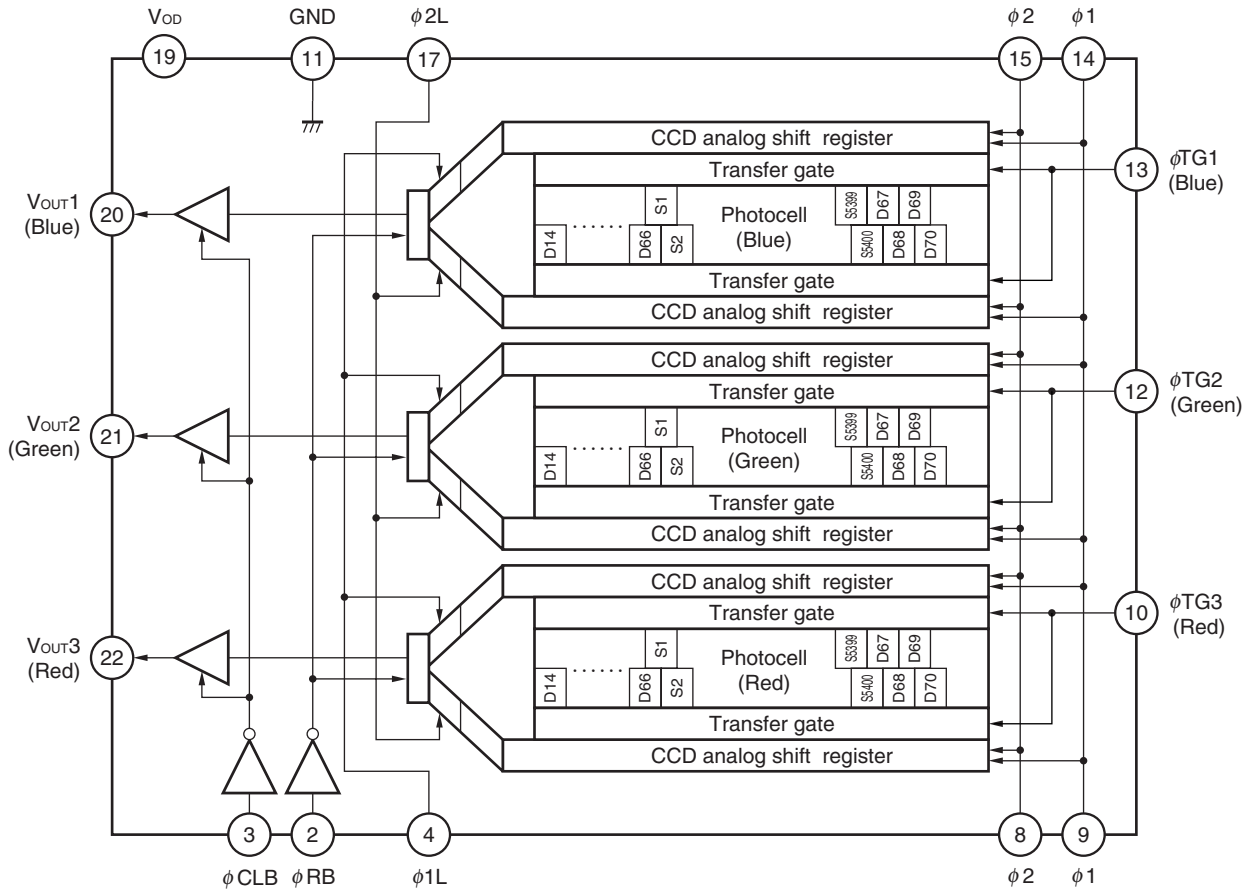

PIN CONFIGURATION (Top View)

CCD linear image sensor 22-pin plastic DIP (10.16 mm (400))

• μPD8862CY

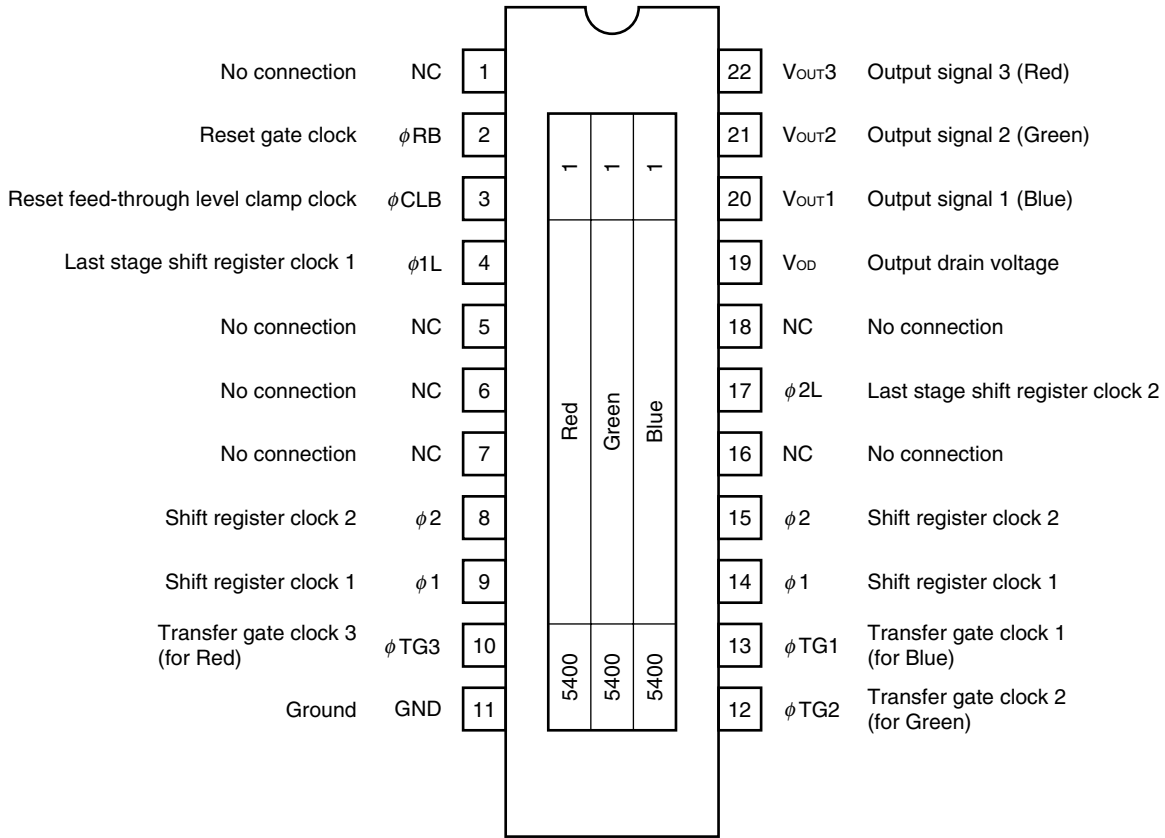

Caution Connect the No connection pins (NC) to GND.

PHOTOCELL STRUCTURE DIAGRAM

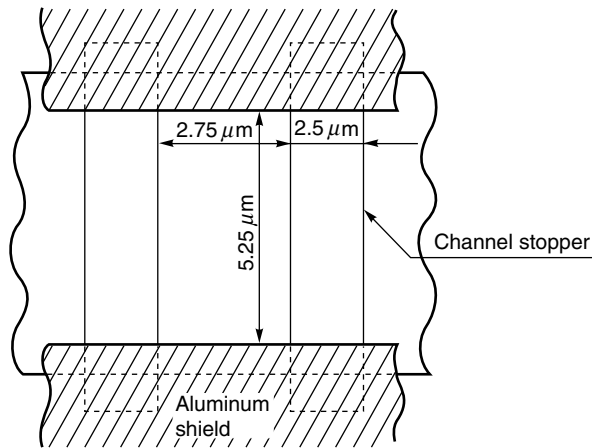

PHOTOCELL ARRAY STRUCTURE DIAGRAM (Line spacing)

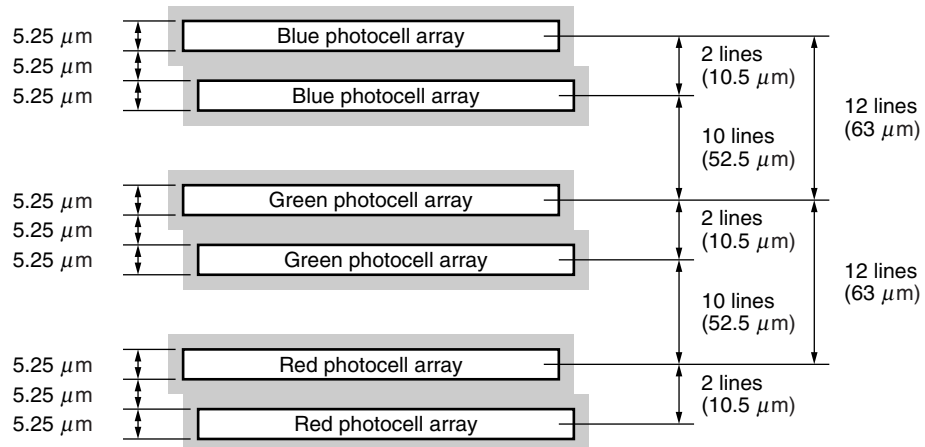

ABSOLUTE MAXIMUM RATINGS (T_A = +25°C)

Parameter	Symbol	Ratings	Unit
Output drain voltage	V _{OD}	-0.3 to +15	V
Shift register clock voltage	V _{φ1} , V _{φ2} , V _{φ1L} , V _{φ2L}	-0.3 to +8	V
Reset gate clock voltage	V _{φRB}	-0.3 to +8	V
Reset feed-through level clamp clock voltage	V _{φCLB}	-0.3 to +8	V
Transfer gate clock voltage	V _{φTG1} to V _{φTG3}	-0.3 to +8	V
Operating ambient temperature ^{Note}	T _A	0 to +60	°C
Storage temperature	T _{stg}	-40 to +70	°C

Note Use at the condition without dew condensation.

Caution Product quality may suffer if the absolute maximum rating is exceeded even momentarily for any parameter. That is, the absolute maximum ratings are rated values at which the product is on the verge of suffering physical damage, and therefore the product must be used under conditions that ensure that the absolute maximum ratings are not exceeded.

RECOMMENDED OPERATING CONDITIONS (T_A = +25°C)

Parameter	Symbol	Min.	Typ.	Max.	Unit
Output drain voltage	V _{OD}	11.4	12.0	12.6	V
Shift register clock high level	V _{φ1_H} , V _{φ2_H} , V _{φ1LH} , V _{φ2LH}	4.75	5.0	5.5	V
Shift register clock low level	V _{φ1_L} , V _{φ2_L} , V _{φ1LL} , V _{φ2LL}	-0.3	0	+0.25	V
Reset gate clock high level	V _{φRBH}	4.5	5.0	5.5	V
Reset gate clock low level	V _{φRBL}	-0.3	0	+0.5	V
Reset feed-through level clamp clock high level	V _{φCLBH}	4.5	5.0	5.5	V
Reset feed-through level clamp clock low level	V _{φCLBL}	-0.3	0	+0.5	V
Transfer gate clock high level	V _{φTG1H} to V _{φTG3H}	4.75	V _{φ1_H} ^{Note}	V _{φ1_H} ^{Note}	V
Transfer gate clock low level	V _{φTG1L} to V _{φTG3L}	-0.3	0	+0.15	V
Data rate	f _{φRB}	-	2.0	6.0	MHz

Note When Transfer gate clock high level (V_{φTG1H} to V_{φTG3H}) is higher than Shift register clock high level (V_{φ1_H}), Image lag can increase.

ELECTRICAL CHARACTERISTICS

$T_A = +25^\circ\text{C}$, $V_{OD} = 12\text{ V}$, data rate ($f_{\phi RB}$) = 2 MHz, storage time = 5.5 ms, input signal clock = 5 V_{p-p},
light source : 3200 K halogen lamp + C-500S (infrared cut filter, t = 1 mm) + HA-50 (heat absorbing filter, t = 3 mm)

Parameter	Symbol	Test Conditions	Min.	Typ.	Max.	Unit
Saturation voltage	V _{sat}		2.0	2.5	–	V
Saturation exposure	Red	SER	–	0.421	–	lx•s
	Green	SEG	–	0.477	–	lx•s
	Blue	SEB	–	0.740	–	lx•s
Photo response non-uniformity	PRNU	V _{OUT} = 1.0 V	–	6	20	%
Average dark signal	ADS	Light shielding	–	0.2	2.0	mV
Dark signal non-uniformity	DSNU	Light shielding	–	1.5	5.0	mV
Power consumption	P _w		–	360	540	mW
Output impedance	Z _o		–	0.35	1	kΩ
Response	Red	R _R	4.15	5.94	7.73	V/lx•s
	Green	R _G	3.66	5.24	6.82	V/lx•s
	Blue	R _B	2.36	3.38	4.39	V/lx•s
Image lag	IL	V _{OUT} = 1.0 V	–	3.0	7.0	%
Offset level ^{Note 1}	V _{OS}		4.5	6.0	7.5	V
Output fall delay time ^{Note 2}	t _d	V _{OUT} = 1.0 V, t ₁ ' , t ₂ ' = 5 ns	–	25	–	ns
Total transfer efficiency	TTE	V _{OUT} = 1.0 V, data rate = 6 MHz	92	98	–	%
Register imbalance	RI	V _{OUT} = 1.0 V	–	1.0	4.0	%
Response peak	Red		–	630	–	nm
	Green		–	540	–	nm
	Blue		–	460	–	nm
Dynamic range	DR1	V _{sat} /DSNU	–	1666	–	times
	DR2	V _{sat} /σCDS	–	2500	–	times
Reset feed-through noise ^{Note 1}	RFTN	Light shielding	–2000	+300	+1000	mV
Random noise (CDS)	σCDS	Light shielding	–	1.0	–	mV

Notes 1. Refer to **TIMING CHART 2, 3.**

2. When each fall time of φ1L and φ2L (t₁' , t₂') is the Typ. value (refer to **TIMING CHART 2, 3**).

INPUT PIN CAPACITANCE (T_A = +25°C, V_{OD} = 12 V)

Parameter	Symbol	Pin name	Pin No.	Min.	Typ.	Max.	Unit
Shift register clock pin capacitance 1	C _{φ1}	φ 1	9	–	250	–	pF
			14	–	250	–	pF
	φ 1 total capacitance			–	500	–	pF
Shift register clock pin capacitance 2	C _{φ2}	φ 2	8	–	250	–	pF
			15	–	250	–	pF
	φ 2 total capacitance			–	500	–	pF
Last stage shift register clock pin capacitance	C _{φL}	φ 1L	4	–	10	–	pF
		φ 2L	17	–	10	–	pF
Reset gate clock pin capacitance	C _{φRB}	φ RB	2	–	10	–	pF
Reset feed-through level clamp clock pin capacitance	C _{φCLB}	φ CLB	3	–	10	–	pF
Transfer gate clock pin capacitance	C _{φTG}	φ TG1	13	–	100	–	pF
		φ TG2	12	–	100	–	pF
		φ TG3	10	–	100	–	pF

Remarks 1. Pins 9 and 14 (φ1), 8 and 15 (φ2) are each connected inside of the device.

2. C_{φ1} and C_{φ2} show the equivalent capacity of the real drive including the capacity of between φ 1 and φ 2.

TIMING CHART 1-1 (Bit clamp mode, for each color)

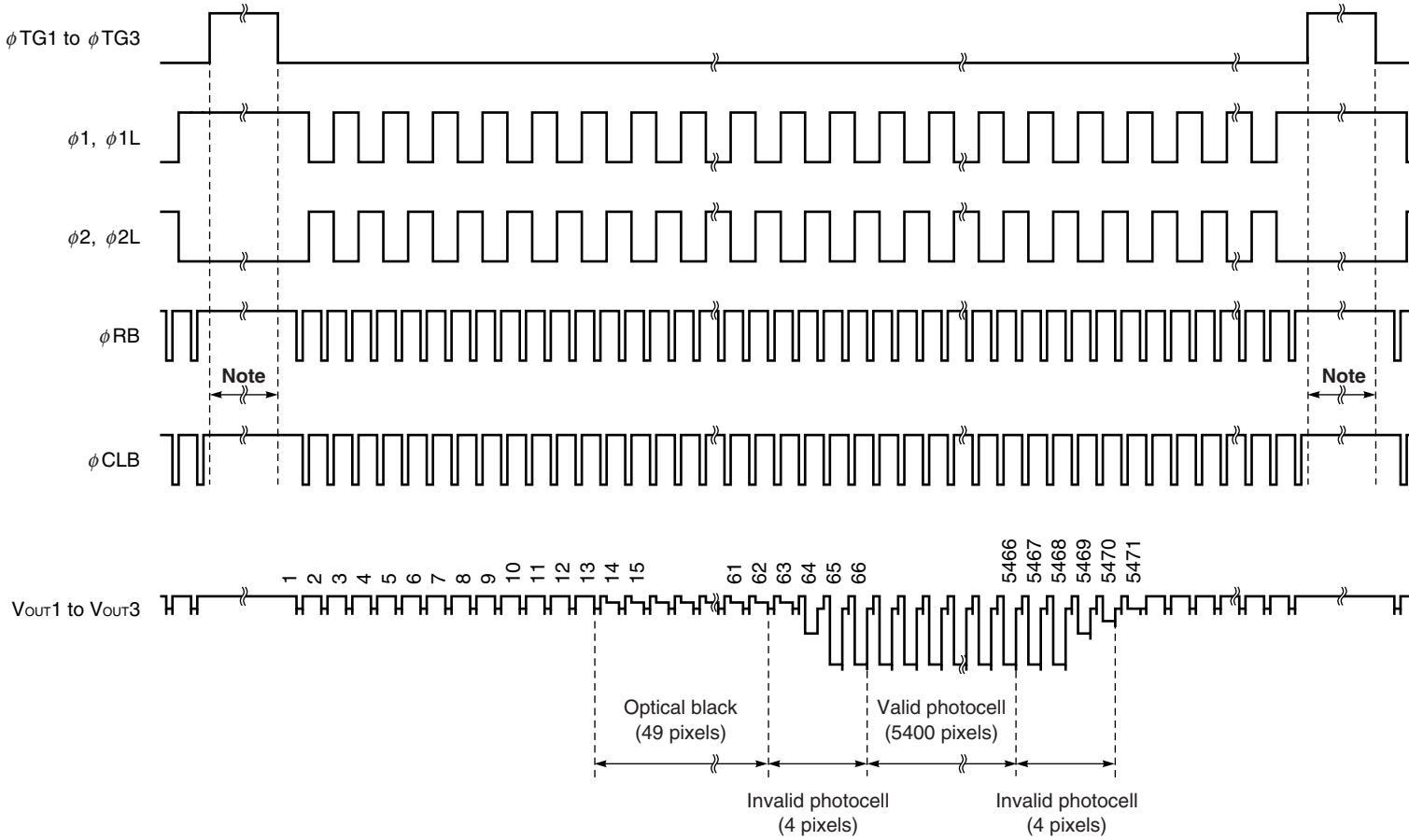

Note Set the ϕ RB and ϕ CLB to high level during this period.

TIMING CHART 1-2 (Line clamp mode, for each color)

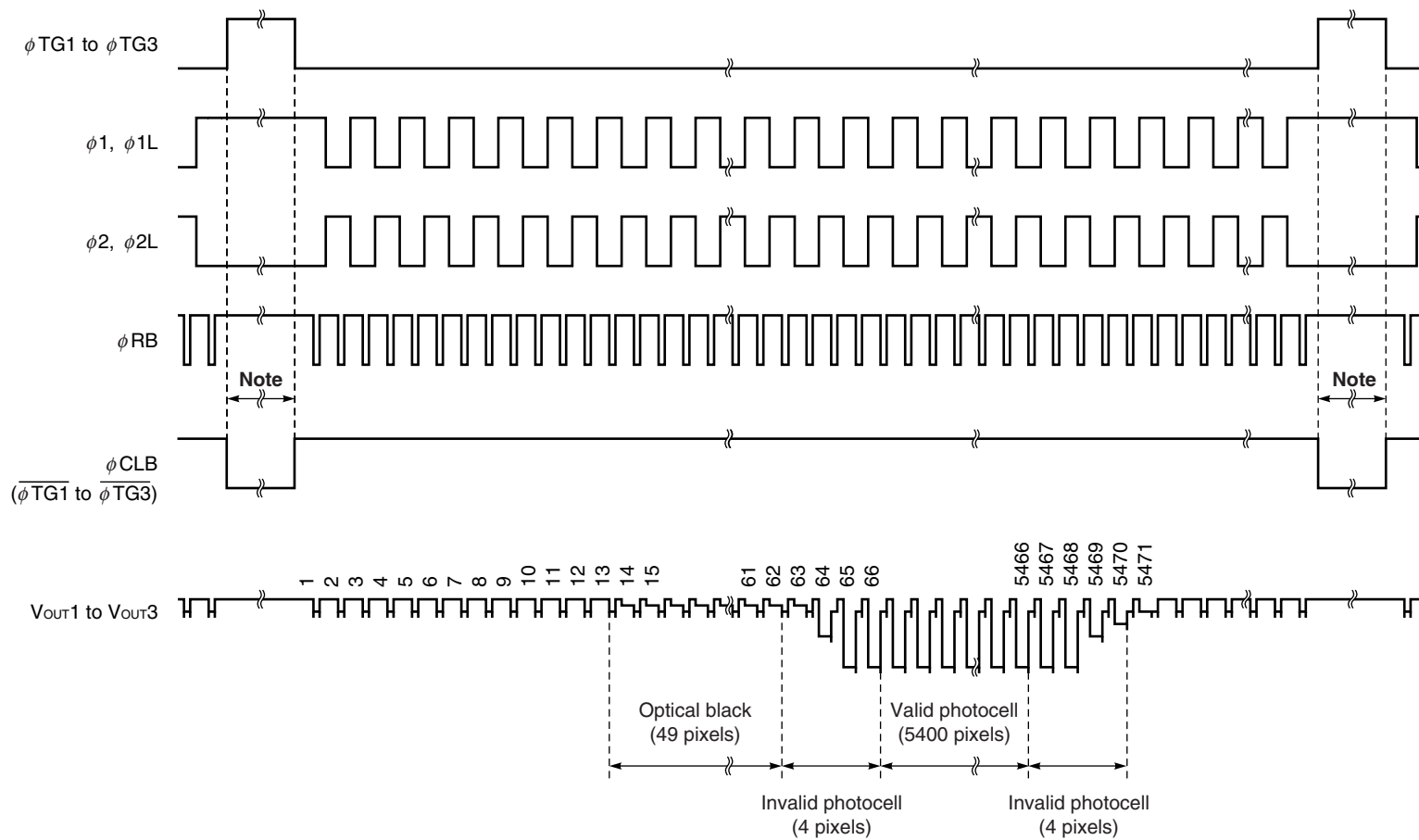

Note Set the ϕ RB to high level during this period.

Remark Inverse pulse of the ϕ TG1 to ϕ TG3 can be used as ϕ CLB.

TIMING CHART 2 (Bit clamp mode, for each color)

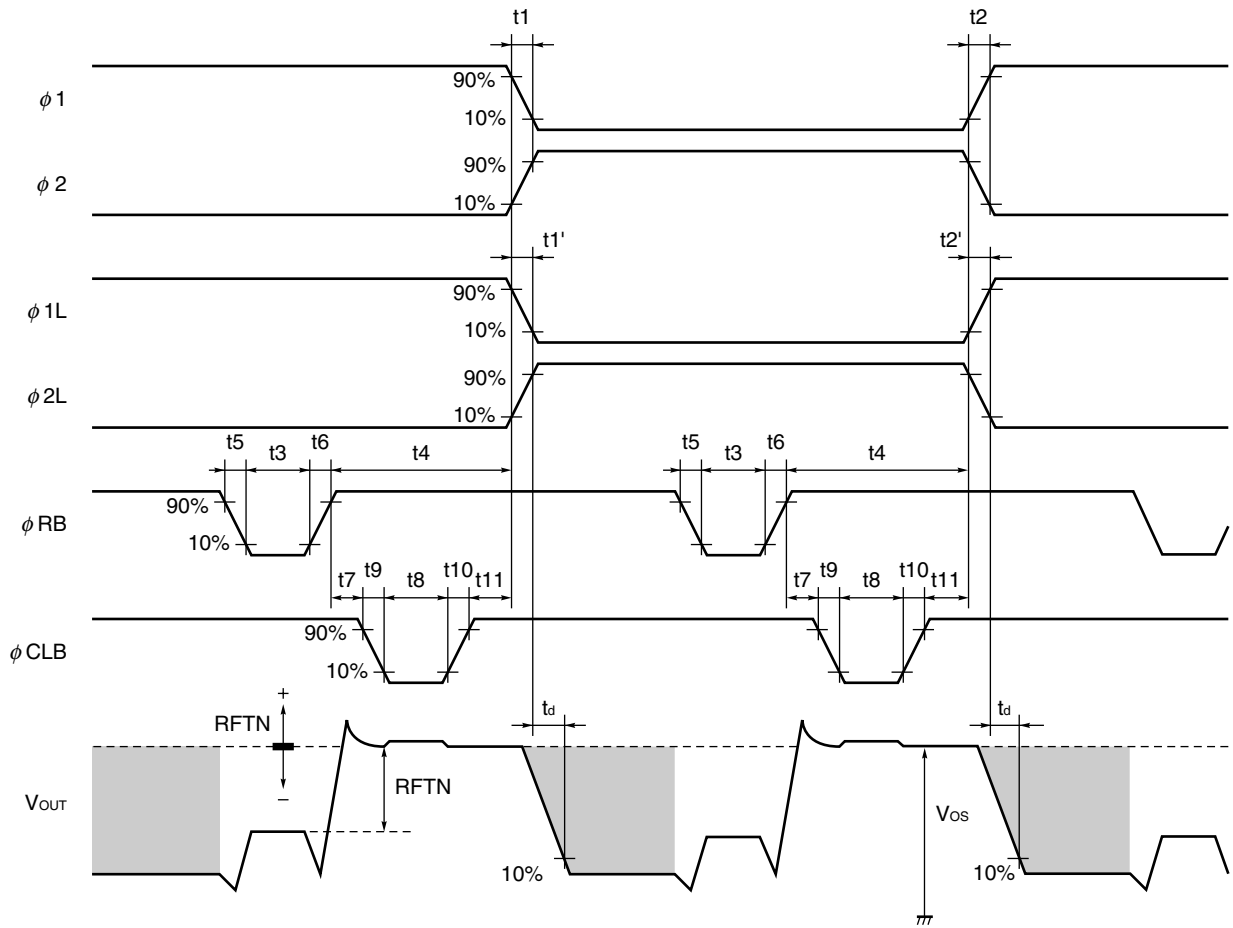

Symbol	Min.	Typ.	Max.	Unit
t1, t2	0	25	–	ns
t1', t2'	0	5	–	ns
t3	20	100	–	ns
t4	30	150	–	ns
t5, t6	0	25	–	ns
t7	-5 ^{Note}	25	–	ns
t8	20	100	–	ns
t9, t10	0	25	–	ns
t11	5	25	–	ns

Note Min. of t7 shows that the ϕRB and ϕCLB overlap each other.

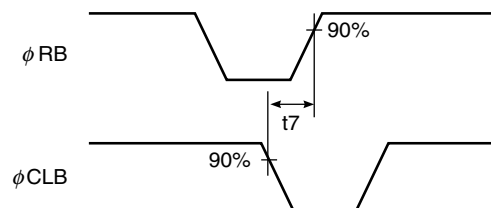

TIMING CHART 3 (Line clamp mode, for each color)

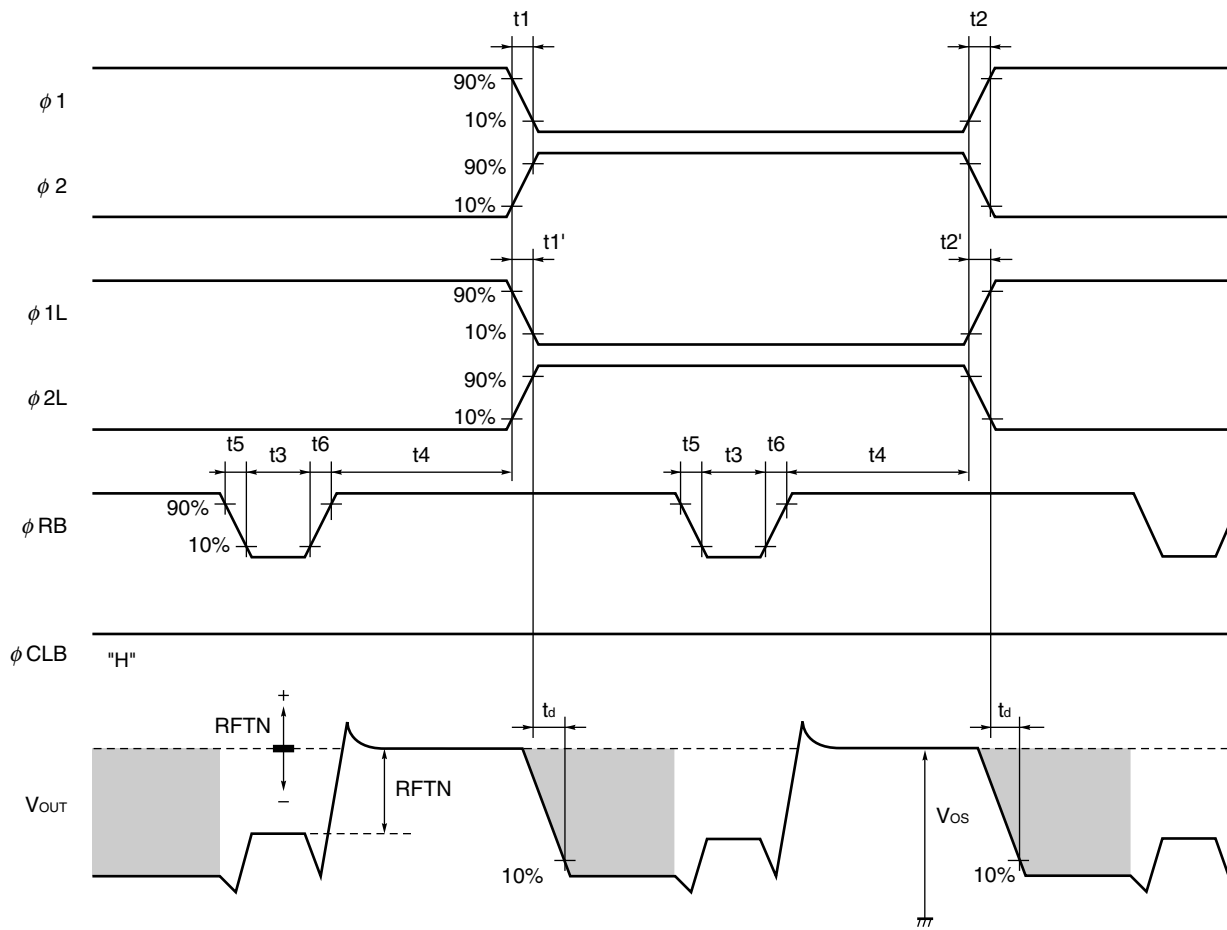

Symbol	Min.	Typ.	Max.	Unit
t1, t2	0	25	–	ns
t1', t2'	0	5	–	ns
t3	20	100	–	ns
t4	30	150	–	ns
t5, t6	0	25	–	ns

φTG1 to φTG3, φ1, φ2 TIMING CHART

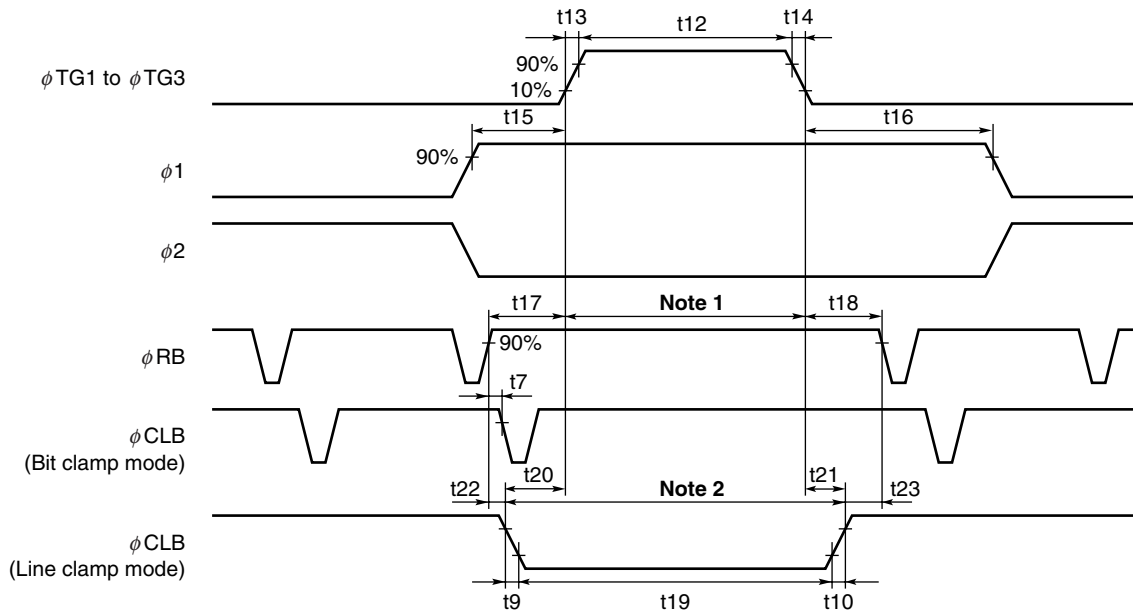

Symbol	Min.	Typ.	Max.	Unit
t7	-5 ^{Note 3}	25	-	ns
t9, t10	0	25	-	ns
t12	5000	10000	50000	ns
t13, t14	0	50	-	ns
t15, t16	900	1000	-	ns
t17, t18	200	400	-	ns
t19	t12	t12	50000	ns
t20, t21	0	50	-	ns
t22, t23	0	350	-	ns

- Notes**
1. Set the φRB and φCLB to high level during this period.
 2. Set the φRB to high level during this period.
 3. Min. of t7 shows that the φRB and φCLB overlap each other.

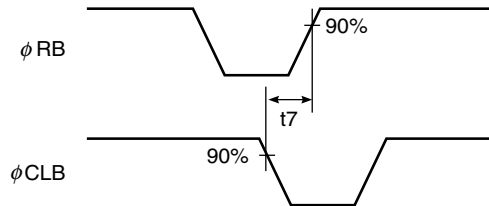

Remark Inverse pulse of the φTG1 to φTG3 can be used as φCLB.

$\phi 1, \phi 2$ cross points

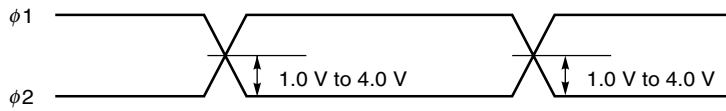

$\phi 1, \phi 2L$ cross points

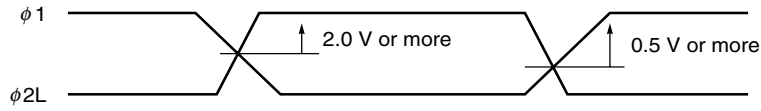

$\phi 2, \phi 1L$ cross points

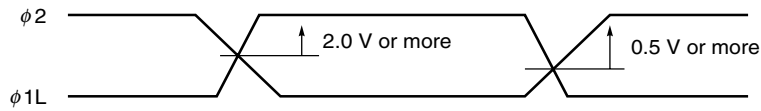

Remark Adjust cross points ($\phi 1, \phi 2$), ($\phi 1, \phi 2L$) and ($\phi 2, \phi 1L$) with input resistance of each pin.

DEFINITIONS OF CHARACTERISTIC ITEMS

1. Saturation voltage : **V_{sat}**
Output signal voltage at which the response linearity is lost.

2. Saturation exposure : **SE**
Product of intensity of illumination (lx) and storage time (s) when saturation of output voltage occurs.

3. Photo response non-uniformity : **PRNU**
The output signal non-uniformity of all the valid pixels when the photosensitive surface is applied with the light of uniform illumination. This is calculated by the following formula.

$$PRNU (\%) = \frac{\Delta x}{\bar{x}} \times 100$$

Δx : maximum of |x_j - \bar{x} |

$$\bar{x} = \frac{\sum_{j=1}^{5400} x_j}{5400}$$

x_j : Output voltage of valid pixel number j

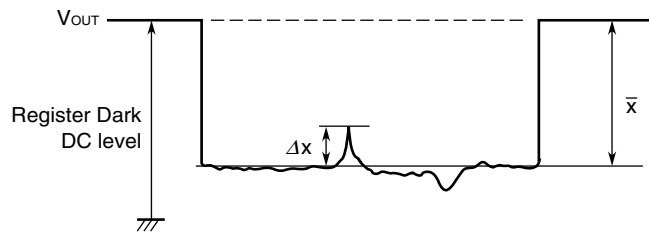

4. Average dark signal : **ADS**
Average output signal voltage of all the valid pixels at light shielding. This is calculated by the following formula.

$$ADS (mV) = \frac{\sum_{j=1}^{5400} d_j}{5400}$$

d_j : Dark signal of valid pixel number j

5. Dark signal non-uniformity : **DSNU**

Absolute maximum of the difference between ADS and voltage of the highest or lowest output pixel of all the valid pixels at light shielding. This is calculated by the following formula.

$$\text{DSNU (mV)} : \text{maximum of } |d_j - \text{ADS}|_{j=1 \text{ to } 5400}$$

d_j : Dark signal of valid pixel number j

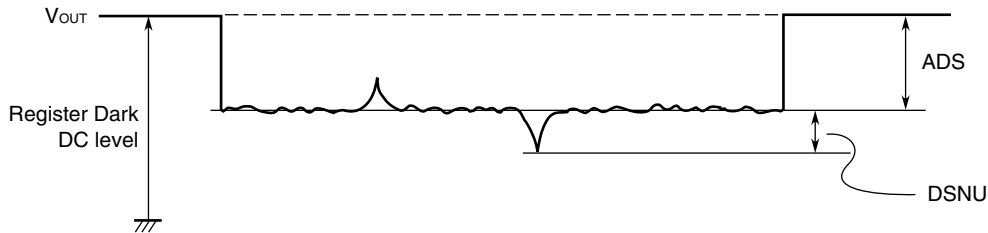

6. Output impedance : **Zo**

Impedance of the output pins viewed from outside.

7. Response : **R**

Output voltage divided by exposure ($I \times s$).

Note that the response varies with a light source (spectral characteristic).

8. Image lag : **IL**

The rate between the last output voltage and the next one after read out the data of a line.

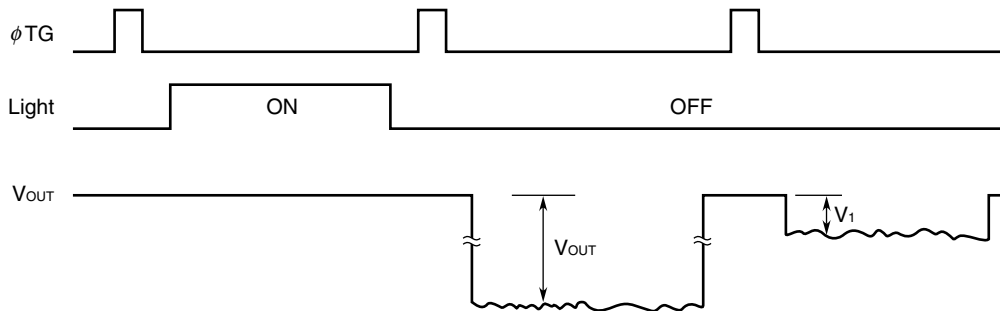

$$\text{IL (\%)} = \frac{V_1}{V_{\text{OUT}}} \times 100$$

9. Register imbalance: **RI**

The rate of the difference between the averages of the output voltage of Odd and Even pixels, against the average output voltage of all the valid pixels.

$$RI (\%) = \frac{\frac{2}{n} \left| \sum_{j=1}^{\frac{n}{2}} (V_{2j-1} - V_{2j}) \right|}{\frac{1}{n} \sum_{j=1}^n V_j} \times 100$$

n : Number of valid pixels
 V_j : Output voltage of each pixel

10. Random noise (CDS) : **σCDS**

Random noise σCDS is defined as the standard deviation of a valid pixel output signal with 100 times (=100 lines) data sampling at dark (light shielding). σCDS is calculated by the following procedure.

1. One valid photocell in one reading is fixed as measurement point.
2. The output level is measured during the reset feed-through period which is averaged over 100 ns to get “VD_i”.
3. The output level is measured during the video output time averaged over 100 ns to get “VO_i”.
4. The correlated double sampling output is defined by VCDS_i = VD_i – VO_i
5. Repeat the above procedure (1 to 4) for 100 times (= 100 lines).
6. Calculate the standard deviation σCDS using the following equation.

$$\sigma_{CDS} (mV) = \sqrt{\frac{\sum_{i=1}^{100} (VCDS_i - \bar{V})^2}{100}}, \quad \bar{V} = \frac{1}{100} \sum_{i=1}^{100} VCDS_i$$

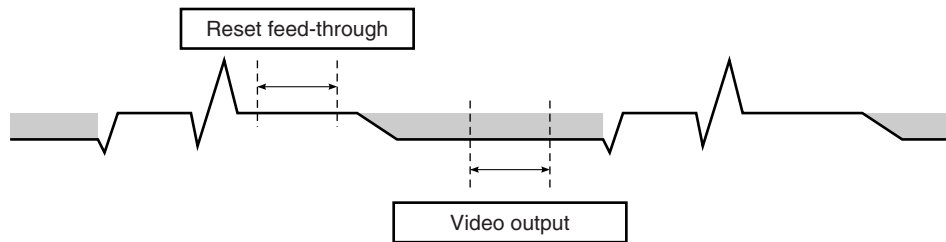

STANDARD CHARACTERISTIC CURVES (Reference Value)

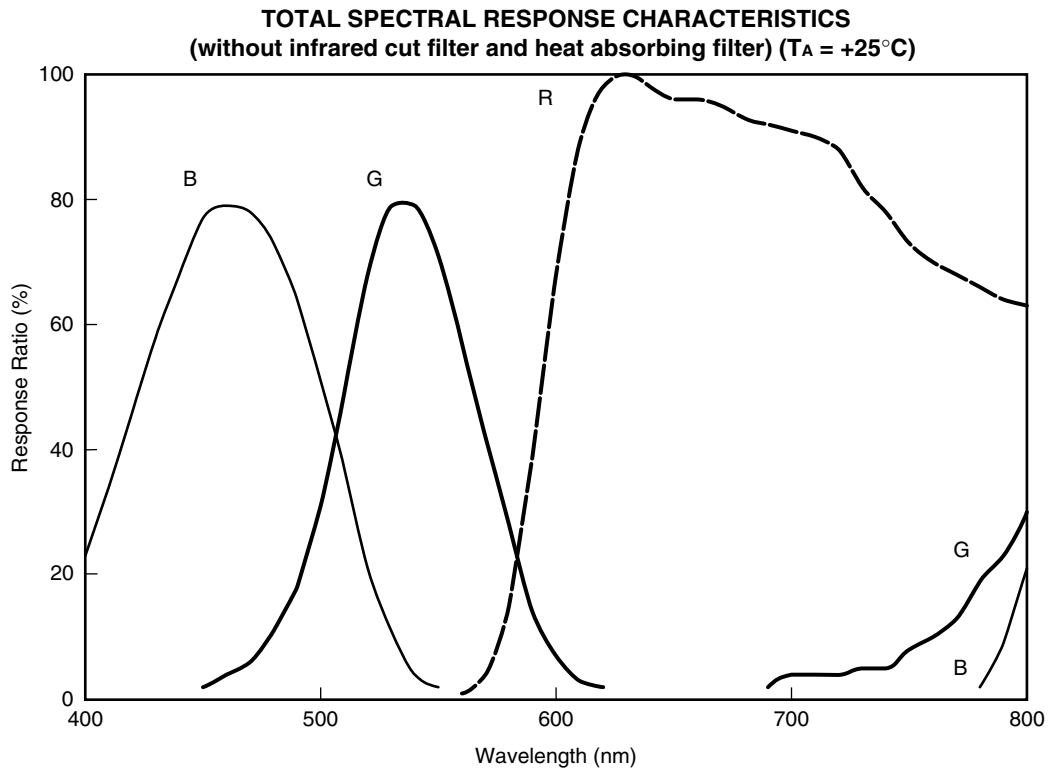
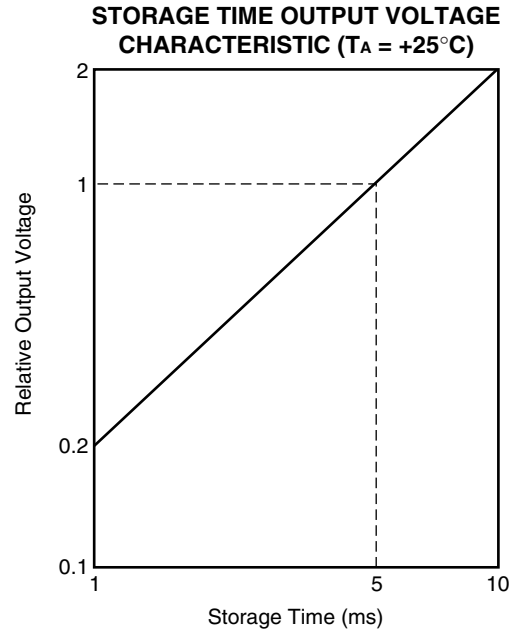
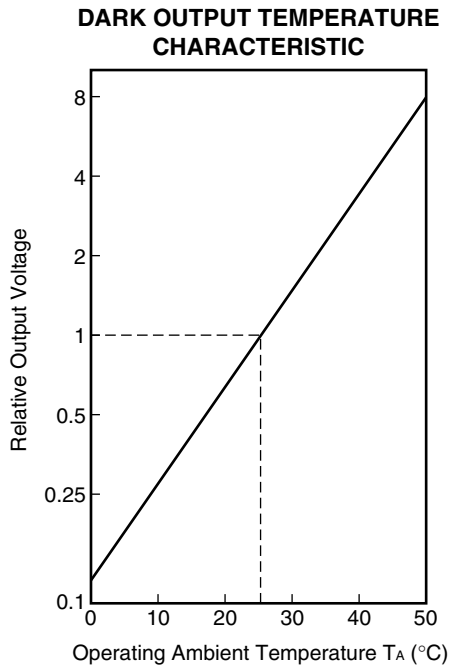

APPLICATION CIRCUIT EXAMPLE

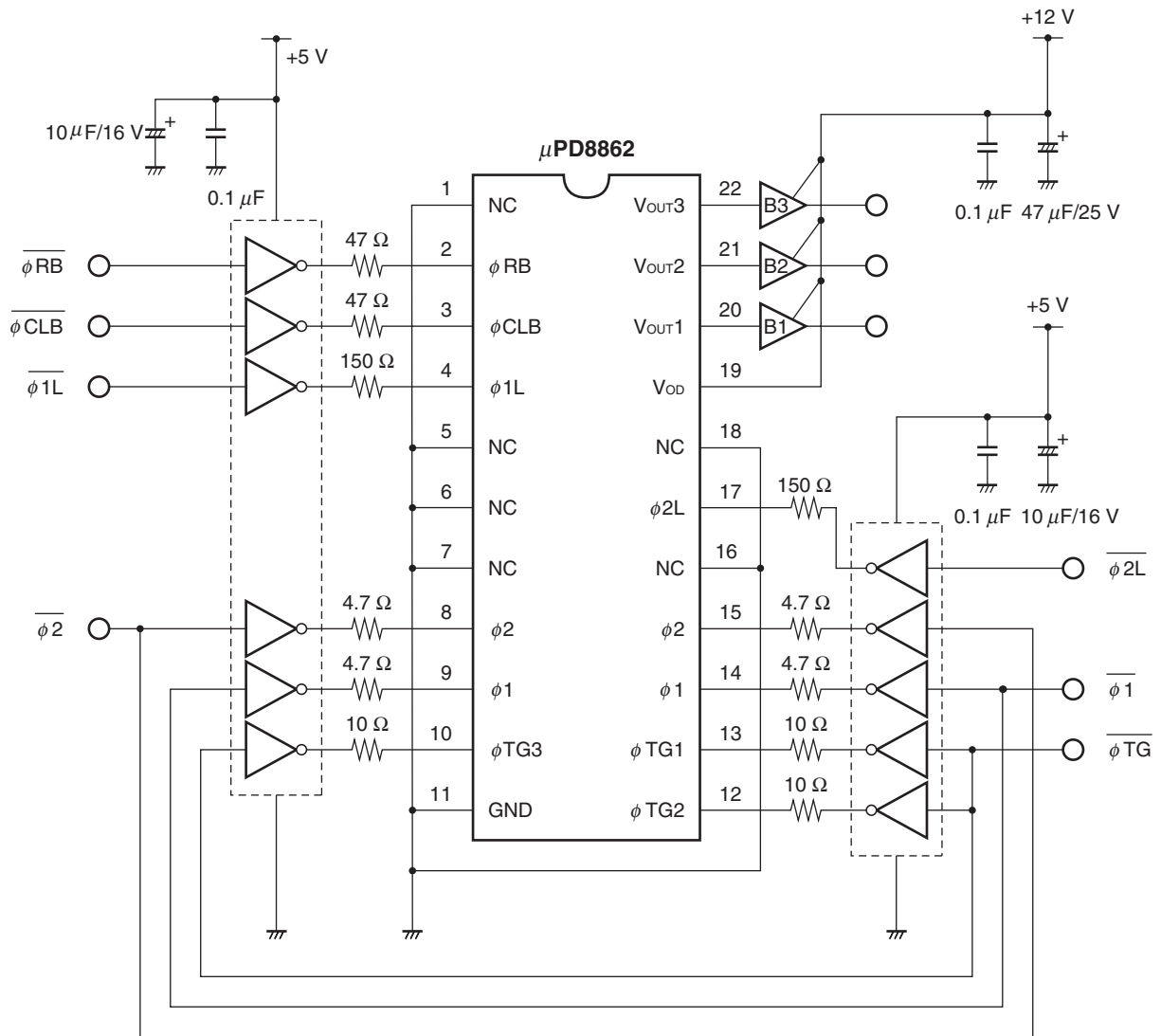

Caution Connect the No connection pins (NC) to GND.

Remarks 1. The inverters shown in the above application circuit example are the 74HC04 (data rate < 2 MHz) or the 74AC04 (2 ≤ data rate < 6 MHz).

2. Inverters B1 to B3 in the above application circuit example are shown in the figure below.

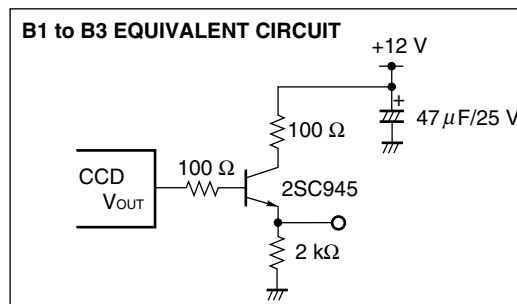

★ PACKAGE DRAWING

μPD8862CY
 CCD LINEAR IMAGE SENSOR 22-PIN PLASTIC DIP (10.16 mm (400))

(Unit : mm)

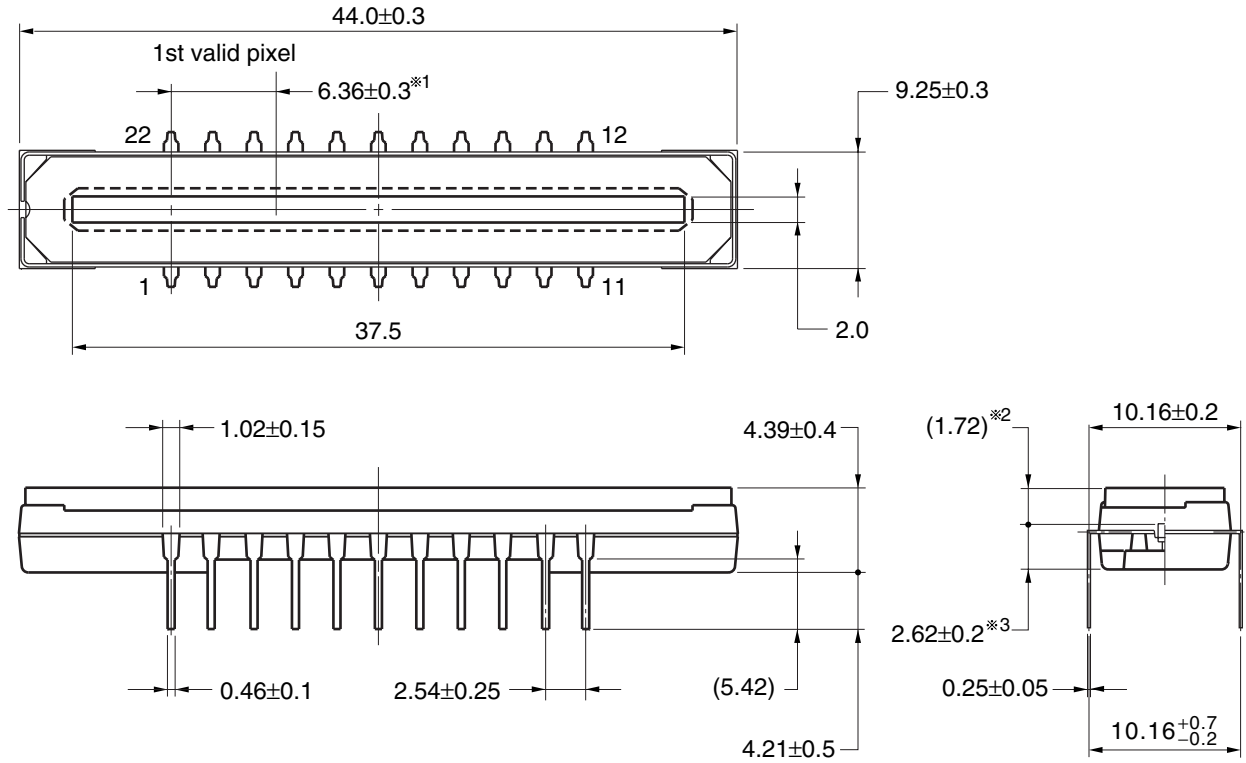

Name	Dimensions	Refractive index
Plastic cap	42.9×8.35×0.7	1.5

- ※1 1st valid pixel ↔ The center of the pin1
- ※2 The surface of the CCD chip ↔ The top of the cap
- ※3 The bottom of the package ↔ The surface of the CCD chip

22C-1CCD-PKG12-2

RECOMMENDED SOLDERING CONDITIONS

When soldering this product, it is highly recommended to observe the conditions as shown below.

If other soldering processes are used, or if the soldering is performed under different conditions, please make sure to consult with our sales offices.

Type of Through-hole Device

μPD8862CY : CCD linear image sensor 22-pin plastic DIP (10.16 mm (400))

Process	Conditions
Partial heating method	Pin temperature : 300 °C or below, Heat time : 3 seconds or less (per pin)

- Cautions**
1. **During assembly care should be taken to prevent solder or flux from contacting the plastic cap. The optical characteristics could be degraded by such contact.**
 2. **Soldering by the solder flow method may have deleterious effects on prevention of plastic cap soiling and heat resistance. So the method cannot be guaranteed.**

NOTES ON HANDLING THE PACKAGES

① DUST AND DIRT PROTECTING

The optical characteristics of the CCD will be degraded if the cap is scratched during cleaning. Don't either touch plastic cap surface by hand or have any object come in contact with plastic cap surface. Should dirt stick to a plastic cap surface, blow it off with an air blower. For dirt stuck through electricity ionized air is recommended. And if the plastic cap surface is grease stained, clean with our recommended solvents.

○ CLEANING THE PLASTIC CAP

Care should be taken when cleaning the surface to prevent scratches.
 We recommend cleaning the cap with a soft cloth moistened with one of the recommended solvents below. Excessive pressure should not be applied to the cap during cleaning. If the cap requires multiple cleanings it is recommended that a clean surface or cloth be used.

○ RECOMMENDED SOLVENTS

The following are the recommended solvents for cleaning the CCD plastic cap.
 Use of solvents other than these could result in optical or physical degradation in the plastic cap. Please consult your sales office when considering an alternative solvent.

Solvents	Symbol
Ethyl Alcohol	EtOH
Methyl Alcohol	MeOH
Isopropyl Alcohol	IPA
N-methyl Pyrrolidone	NMP

② MOUNTING OF THE PACKAGE

The application of an excessive load to the package may cause the package to warp or break, or cause chips to come off internally. Particular care should be taken when mounting the package on the circuit board. Don't have any object come in contact with plastic cap. You should not reform the lead frame. We recommended to use a IC-inserter when you assemble to PCB.

Also, be care that the any of the following can cause the package to crack or dust to be generated.

1. Applying heat to the external leads for an extended period of time with soldering iron.
2. Applying repetitive bending stress to the external leads.
3. Rapid cooling or heating

③ OPERATE AND STORAGE ENVIRONMENTS

Operate in clean environments. CCD image sensors are precise optical equipment that should not be subject to mechanical shocks. Exposure to high temperatures or humidity will affect the characteristics. So avoid storage or usage in such conditions.

Keep in a case to protect from dust and dirt. Dew condensation may occur on CCD image sensors when the devices are transported from a low-temperature environment to a high-temperature environment. Avoid such rapid temperature changes.

For more details, refer to our document "Review of Quality and Reliability Handbook" (C12769E)

④ ELECTROSTATIC BREAKDOWN

CCD image sensor is protected against static electricity, but destruction due to static electricity is sometimes detected. Before handling be sure to take the following protective measures.

1. Ground the tools such as soldering iron, radio cutting pliers or of pincer.
2. Install a conductive mat or on the floor or working table to prevent the generation of static electricity.
3. Either handle bare handed or use non-chargeable gloves, clothes or material.
4. Ionized air is recommended for discharge when handling CCD image sensor.
5. For the shipment of mounted substrates, use box treated for prevention of static charges.
6. Anyone who is handling CCD image sensors, mounting them on PCBs or testing or inspecting PCBs on which CCD image sensors have been mounted must wear anti-static bands such as wrist straps and ankle straps which are grounded via a series resistance connection of about 1 MΩ.

[MEMO]

NOTES FOR CMOS DEVICES**① PRECAUTION AGAINST ESD FOR SEMICONDUCTORS**

Note:

Strong electric field, when exposed to a MOS device, can cause destruction of the gate oxide and ultimately degrade the device operation. Steps must be taken to stop generation of static electricity as much as possible, and quickly dissipate it once, when it has occurred. Environmental control must be adequate. When it is dry, humidifier should be used. It is recommended to avoid using insulators that easily build static electricity. Semiconductor devices must be stored and transported in an anti-static container, static shielding bag or conductive material. All test and measurement tools including work bench and floor should be grounded. The operator should be grounded using wrist strap. Semiconductor devices must not be touched with bare hands. Similar precautions need to be taken for PW boards with semiconductor devices on it.

② HANDLING OF UNUSED INPUT PINS FOR CMOS

Note:

No connection for CMOS device inputs can be cause of malfunction. If no connection is provided to the input pins, it is possible that an internal input level may be generated due to noise, etc., hence causing malfunction. CMOS devices behave differently than Bipolar or NMOS devices. Input levels of CMOS devices must be fixed high or low by using a pull-up or pull-down circuitry. Each unused pin should be connected to V_{DD} or GND with a resistor, if it is considered to have a possibility of being an output pin. All handling related to the unused pins must be judged device by device and related specifications governing the devices.

③ STATUS BEFORE INITIALIZATION OF MOS DEVICES

Note:

Power-on does not necessarily define initial status of MOS device. Production process of MOS does not define the initial operation status of the device. Immediately after the power source is turned ON, the devices with reset function have not yet been initialized. Hence, power-on does not guarantee out-pin levels, I/O settings or contents of registers. Device is not initialized until the reset signal is received. Reset operation must be executed immediately after power-on for devices having reset function.

- **The information in this document is current as of July, 2003. The information is subject to change without notice. For actual design-in, refer to the latest publications of NEC Electronics data sheets or data books, etc., for the most up-to-date specifications of NEC Electronics products. Not all products and/or types are available in every country. Please check with an NEC Electronics sales representative for availability and additional information.**
- No part of this document may be copied or reproduced in any form or by any means without the prior written consent of NEC Electronics. NEC Electronics assumes no responsibility for any errors that may appear in this document.
- NEC Electronics does not assume any liability for infringement of patents, copyrights or other intellectual property rights of third parties by or arising from the use of NEC Electronics products listed in this document or any other liability arising from the use of such products. No license, express, implied or otherwise, is granted under any patents, copyrights or other intellectual property rights of NEC Electronics or others.
- Descriptions of circuits, software and other related information in this document are provided for illustrative purposes in semiconductor product operation and application examples. The incorporation of these circuits, software and information in the design of a customer's equipment shall be done under the full responsibility of the customer. NEC Electronics assumes no responsibility for any losses incurred by customers or third parties arising from the use of these circuits, software and information.
- While NEC Electronics endeavors to enhance the quality, reliability and safety of NEC Electronics products, customers agree and acknowledge that the possibility of defects thereof cannot be eliminated entirely. To minimize risks of damage to property or injury (including death) to persons arising from defects in NEC Electronics products, customers must incorporate sufficient safety measures in their design, such as redundancy, fire-containment and anti-failure features.
- NEC Electronics products are classified into the following three quality grades: "Standard", "Special" and "Specific".

The "Specific" quality grade applies only to NEC Electronics products developed based on a customer-designated "quality assurance program" for a specific application. The recommended applications of an NEC Electronics product depend on its quality grade, as indicated below. Customers must check the quality grade of each NEC Electronics product before using it in a particular application.

"Standard": Computers, office equipment, communications equipment, test and measurement equipment, audio and visual equipment, home electronic appliances, machine tools, personal electronic equipment and industrial robots.

"Special": Transportation equipment (automobiles, trains, ships, etc.), traffic control systems, anti-disaster systems, anti-crime systems, safety equipment and medical equipment (not specifically designed for life support).

"Specific": Aircraft, aerospace equipment, submersible repeaters, nuclear reactor control systems, life support systems and medical equipment for life support, etc.

The quality grade of NEC Electronics products is "Standard" unless otherwise expressly specified in NEC Electronics data sheets or data books, etc. If customers wish to use NEC Electronics products in applications not intended by NEC Electronics, they must contact an NEC Electronics sales representative in advance to determine NEC Electronics' willingness to support a given application.

(Note)

- (1) "NEC Electronics" as used in this statement means NEC Electronics Corporation and also includes its majority-owned subsidiaries.
- (2) "NEC Electronics products" means any product developed or manufactured by or for NEC Electronics (as defined above).